



**THE DATASHEET OF  
SN74CB3Q3306APWG4**



## Dual FET Bus Switch 2.5-V/3.3-V Low-Voltage High-Bandwidth Bus Switch

 Check for Samples: [SN74CB3Q3306A](#)

### FEATURES

- High-Bandwidth Data Path (up to 500 MHz<sup>(1)</sup>)
- 5-V-Tolerant I/Os With Device Powered Up or Powered Down
- Low and Flat ON-State Resistance ( $r_{on}$ ) Characteristics Over Operating Range ( $r_{on} = 4 \Omega$  Typ)
- Rail-to-Rail Switching on Data I/O Ports
  - 0- to 5-V Switching With 3.3-V  $V_{CC}$
  - 0- to 3.3-V Switching With 2.5-V  $V_{CC}$
- Bidirectional Data Flow With Near-Zero Propagation Delay
- Low Input/Output Capacitance Minimizes Loading and Signal Distortion ( $C_{io(OFF)} = 3.5$  pF Typ)
- Fast Switching Frequency ( $f_{OE} = 20$  MHz Max)

(1) For additional information regarding the performance characteristics of the CB3Q family, refer to the TI application report, *CBT-C, CB3T, and CB3Q Signal-Switch Families*, literature number [SCDA008](#).

- Data and Control Inputs Provide Undershoot Clamp Diodes
- Low Power Consumption ( $I_{CC} = 0.25$  mA Typ)
- $V_{CC}$  Operating Range From 2.3 V to 3.6 V
- Data I/Os Support 0- to 5-V Signaling Levels (0.8 V, 1.2 V, 1.5 V, 1.8 V, 2.5 V, 3.3 V, 5 V)
- Control Inputs Can Be Driven by TTL or 5-V/3.3-V CMOS Outputs
- $I_{off}$  Supports Partial-Power-Down Mode Operation
- Latch-Up Performance Exceeds 100 mA Per JESD 78, Class II
- ESD Performance Tested Per JESD 22
  - 2000-V Human-Body Model (A114-B, Class II)
  - 1000-V Charged-Device Model (C101)
- Supports Both Digital and Analog Applications: USB Interface, Differential Signal Interface, Bus Isolation, Low-Distortion Signal Gating

DCU PACKAGE  
(TOP VIEW)

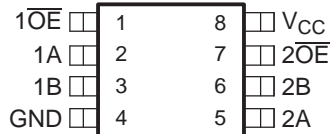

PW PACKAGE  
(TOP VIEW)

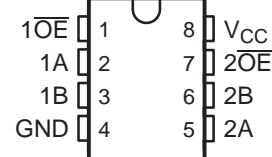

### ORDERING INFORMATION

$T_A$	PACKAGE <sup>(1)</sup>		ORDERABLE PART NUMBER	TOP-SIDE MARKING
–40°C to 85°C	TSSOP – PW	Tube	SN74CB3Q3306APW	BU306A
		Tape and reel	SN74CB3Q3306APWR	
	US8-DCU	Tape and reel	SN74CB3Q3306ADCUR	GA6R <sup>(2)</sup>
			74CB3Q3306ADCURE4	

(1) Package drawings, standard packing quantities, thermal data, symbolization, and PCB design guidelines are available at [www.ti.com/sc/package](http://www.ti.com/sc/package).

(2) The last character designates assembly/test site.



Please be aware that an important notice concerning availability, standard warranty, and use in critical applications of Texas Instruments semiconductor products and disclaimers thereto appears at the end of this data sheet.

# SN74CB3Q3306A

SCDS113E – DECEMBER 2002 – REVISED JANUARY 2011

www.ti.com



These devices have limited built-in ESD protection. The leads should be shorted together or the device placed in conductive foam during storage or handling to prevent electrostatic damage to the MOS gates.

## DESCRIPTION/ORDERING INFORMATION

The SN74CB3Q3306A is a high-bandwidth FET bus switch utilizing a charge pump to elevate the gate voltage of the pass transistor, providing a low and flat ON-state resistance ( $r_{on}$ ). The low and flat ON-state resistance allows for minimal propagation delay and supports rail-to-rail switching on the data input/output (I/O) ports. The device also features low data I/O capacitance to minimize capacitive loading and signal distortion on the data bus. Specifically designed to support high-bandwidth applications, the SN74CB3Q3306A provides an optimized interface solution ideally suited for broadband communications, networking, and data-intensive computing systems.

The SN74CB3Q3306A is organized as two 1-bit switches with separate output-enable ( $\overline{1OE}$ ,  $\overline{2OE}$ ) inputs. It can be used as two 1-bit bus switches or as one 2-bit bus switch. When  $\overline{OE}$  is low, the associated 1-bit bus switch is ON and the A port is connected to the B port, allowing bidirectional data flow between ports. When  $\overline{OE}$  is high, the associated 1-bit bus switch is OFF, and a high-impedance state exists between the A and B ports.

This device is fully specified for partial-power-down applications using  $I_{off}$ . The  $I_{off}$  circuitry prevents damaging current backflow through the device when it is powered down. The device has isolation during power off.

To ensure the high-impedance state during power up or power down,  $\overline{OE}$  should be tied to  $V_{CC}$  through a pullup resistor; the minimum value of the resistor is determined by the current-sinking capability of the driver.

**Table 1. FUNCTION TABLE  
(EACH BUS SWITCH)**

INPUT $\overline{OE}$	INPUT/OUTPUT A	FUNCTION
L	B	A port = B port
H	Z	Disconnect

### LOGIC DIAGRAM (POSITIVE LOGIC)

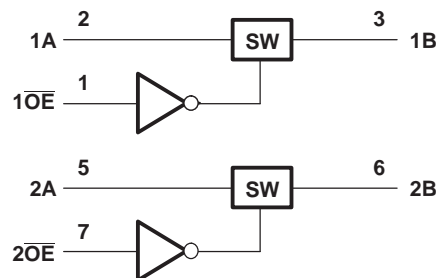

**SIMPLIFIED SCHEMATIC, EACH FET SWITCH (SW)**

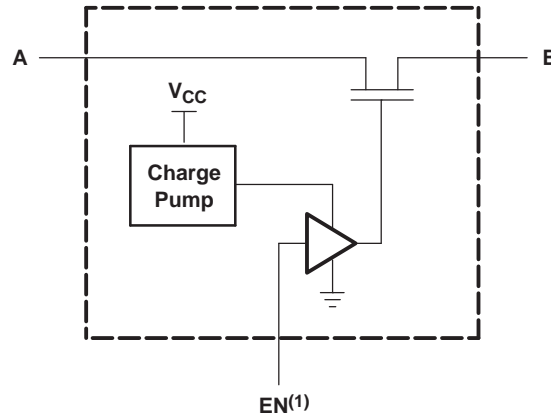

(1) EN is the internal enable signal applied to the switch.

**ABSOLUTE MAXIMUM RATINGS<sup>(1)</sup>**

over operating free-air temperature range (unless otherwise noted)

		MIN	MAX	UNIT
$V_{CC}$	Supply voltage range	-0.5	4.6	V
$V_{IN}$	Control input voltage range <sup>(2) (3)</sup>	-0.5	7	V
$V_{I/O}$	Switch I/O voltage range <sup>(2) (3) (4)</sup>	-0.5	7	V
$I_{IK}$	Control input clamp current		-50	mA
$I_{I/OK}$	I/O port clamp current		-50	mA
$I_{I/O}$	ON-state switch current <sup>(5)</sup>		±64	mA
	Continuous current through each $V_{CC}$ or GND		±100	mA
$\theta_{JA}$	Package thermal impedance <sup>(6)</sup>	DCU	TBD	°C/W
		PW	88	
$T_{stg}$	Storage temperature range	-65	150	°C

- (1) Stresses beyond those listed under "absolute maximum ratings" may cause permanent damage to the device. These are stress ratings only, and functional operation of the device at these or any other conditions beyond those indicated under "recommended operating conditions" is not implied. Exposure to absolute-maximum-rated conditions for extended periods may affect device reliability.
- (2) All voltages are with respect to ground, unless otherwise specified.
- (3) The input and output voltage ratings may be exceeded if the input and output clamp-current ratings are observed.
- (4)  $V_I$  and  $V_O$  are used to denote specific conditions for  $V_{I/O}$ .
- (5)  $I_I$  and  $I_O$  are used to denote specific conditions for  $I_{I/O}$ .
- (6) The package thermal impedance is calculated in accordance with JESD 51-7.

**RECOMMENDED OPERATING CONDITIONS<sup>(1)</sup>**

		MIN	MAX	UNIT	
$V_{CC}$	Supply voltage	2.3	3.6	V	
$V_{IH}$	High-level control input voltage	$V_{CC} = 2.3\text{ V to }2.7\text{ V}$	1.7	5.5	V
		$V_{CC} = 2.7\text{ V to }3.6\text{ V}$	2	5.5	
$V_{IL}$	Low-level control input voltage	$V_{CC} = 2.3\text{ V to }2.7\text{ V}$	0	0.7	V
		$V_{CC} = 2.7\text{ V to }3.6\text{ V}$	0	0.8	
$V_{I/O}$	Data input/output voltage	0	5.5	V	
$T_A$	Operating free-air temperature	-40	85	°C	

- (1) All unused control inputs of the device must be held at  $V_{CC}$  or GND to ensure proper device operation. Refer to the TI application report, *Implications of Slow or Floating CMOS Inputs*, literature number SCBA004.

# SN74CB3Q3306A

SCD5113E – DECEMBER 2002 – REVISED JANUARY 2011

[www.ti.com](http://www.ti.com)

## ELECTRICAL CHARACTERISTICS<sup>(1)</sup>

over recommended operating free-air temperature range (unless otherwise noted)

PARAMETER		TEST CONDITIONS		MIN	TYP <sup>(2)</sup>	MAX	UNIT	
$V_{IK}$		$V_{CC} = 3.6\text{ V}$ ,	$I_I = -18\text{ mA}$			-1.8	V	
$I_{IN}$	Control inputs	$V_{CC} = 3.6\text{ V}$ ,	$V_{IN} = 0\text{ to }5.5\text{ V}$			±1	μA	
$I_{OZ}$ <sup>(3)</sup>		$V_{CC} = 3.6\text{ V}$ ,	$V_O = 0\text{ to }5.5\text{ V}$ , $V_I = 0$ , Switch OFF, $V_{IN} = V_{CC}$ or GND			±1	μA	
$I_{off}$		$V_{CC} = 0$ ,	$V_O = 0\text{ to }5.5\text{ V}$ , $V_I = 0$			1	μA	
$I_{CC}$		$V_{CC} = 3.6\text{ V}$ ,	$I_{I/O} = 0$ , Switch ON or OFF, $V_{IN} = V_{CC}$ or GND		0.25	0.7	mA	
$\Delta I_{CC}$ <sup>(4)</sup>	Control inputs	$V_{CC} = 3.6\text{ V}$ ,	One input at 3 V, Other inputs at $V_{CC}$ or GND			25	μA	
$I_{CCD}$ <sup>(5)</sup>	Per control input	$V_{CC} = 3.6\text{ V}$ ,	A and B ports open, Control input switching at 50% duty cycle		0.03	0.1	mA/ MHz	
$C_{in}$	Control inputs	$V_{CC} = 3.3\text{ V}$ ,	$V_{IN} = 5.5\text{ V}$ , 3.3 V, or 0		2.5	3.5	pF	
$C_{io(OFF)}$		$V_{CC} = 3.3\text{ V}$ ,	Switch OFF, $V_{IN} = V_{CC}$ or GND, $V_{I/O} = 5.5\text{ V}$ , 3.3 V, or 0		3.5	5	pF	
$C_{io(ON)}$		$V_{CC} = 3.3\text{ V}$ ,	Switch ON, $V_{IN} = V_{CC}$ or GND, $V_{I/O} = 5.5\text{ V}$ , 3.3 V, or 0		8	10.5	pF	
$r_{on}$ <sup>(6)</sup>		$V_{CC} = 2.3\text{ V}$ , TYP at $V_{CC} = 2.5\text{ V}$	$V_I = 0$ ,	$I_O = 30\text{ mA}$		4	8	Ω
			$V_I = 1.7\text{ V}$ ,	$I_O = -15\text{ mA}$		5	9	
		$V_{CC} = 3\text{ V}$	$V_I = 0$ ,	$I_O = 30\text{ mA}$		4	6	
			$V_I = 2.4\text{ V}$ ,	$I_O = -15\text{ mA}$		5	8	

(1)  $V_{IN}$  and  $I_{IN}$  refer to control inputs.  $V_I$ ,  $V_O$ ,  $I_I$ , and  $I_O$  refer to data pins.

(2) All typical values are at  $V_{CC} = 3.3\text{ V}$  (unless otherwise noted),  $T_A = 25^\circ\text{C}$ .

(3) For I/O ports, the parameter  $I_{OZ}$  includes the input leakage current.

(4) This is the increase in supply current for each input that is at the specified TTL voltage level, rather than  $V_{CC}$  or GND.

(5) This parameter specifies the dynamic power-supply current associated with the operating frequency of a single control input (see Figure 2).

(6) Measured by the voltage drop between the A and B terminals at the indicated current through the switch. ON-state resistance is determined by the lower of the voltages of the two (A or B) terminals.

## SWITCHING CHARACTERISTICS

over recommended operating free-air temperature range (unless otherwise noted) (see Figure 3)

PARAMETER	FROM (INPUT)	TO (OUTPUT)	$V_{CC} = 2.5\text{ V} \pm 0.2\text{ V}$		$V_{CC} = 3.3\text{ V} \pm 0.3\text{ V}$		UNIT
			MIN	MAX	MIN	MAX	
$f_{OE}$ <sup>(1)</sup>	$\overline{OE}$	A or B		10		20	MHz
$t_{pd}$ <sup>(2)</sup>	A or B	B or A		0.2		0.2	ns
$t_{en}$	$\overline{OE}$	A or B	1.5	6.5	1.5	5.5	ns
$t_{dis}$	$\overline{OE}$	A or B	1	6	1	5	ns

(1) Maximum switching frequency for control input ( $V_O > V_{CC}$ ,  $V_I = 5\text{ V}$ ,  $R_L \geq 1\text{ M}\Omega$ ,  $C_L = 0$ )

(2) The propagation delay is the calculated RC time constant of the typical ON-state resistance of the switch and the specified load capacitance, when driven by an ideal voltage source (zero output impedance).

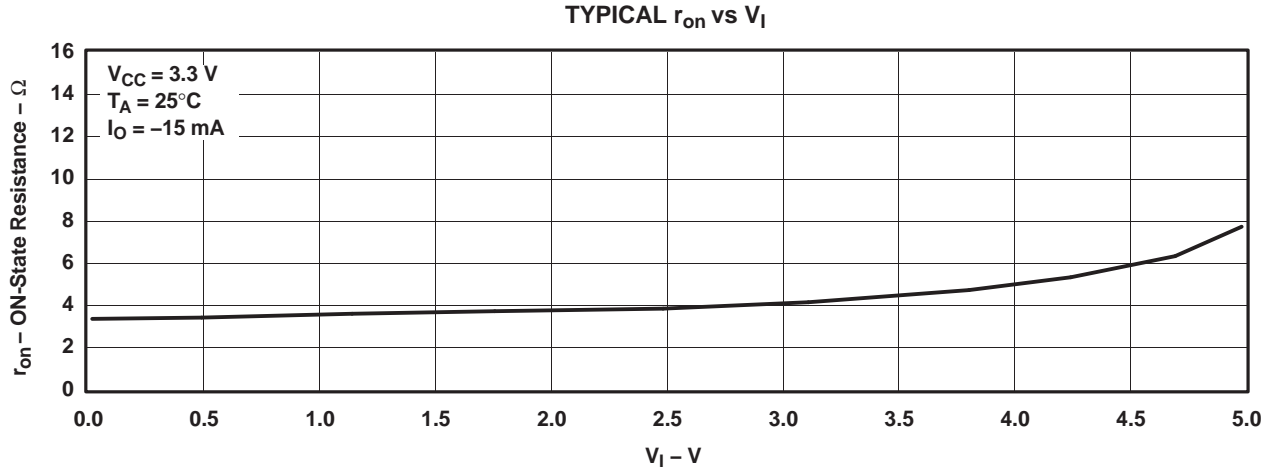

Figure 1. Typical  $r_{on}$  vs  $V_I$

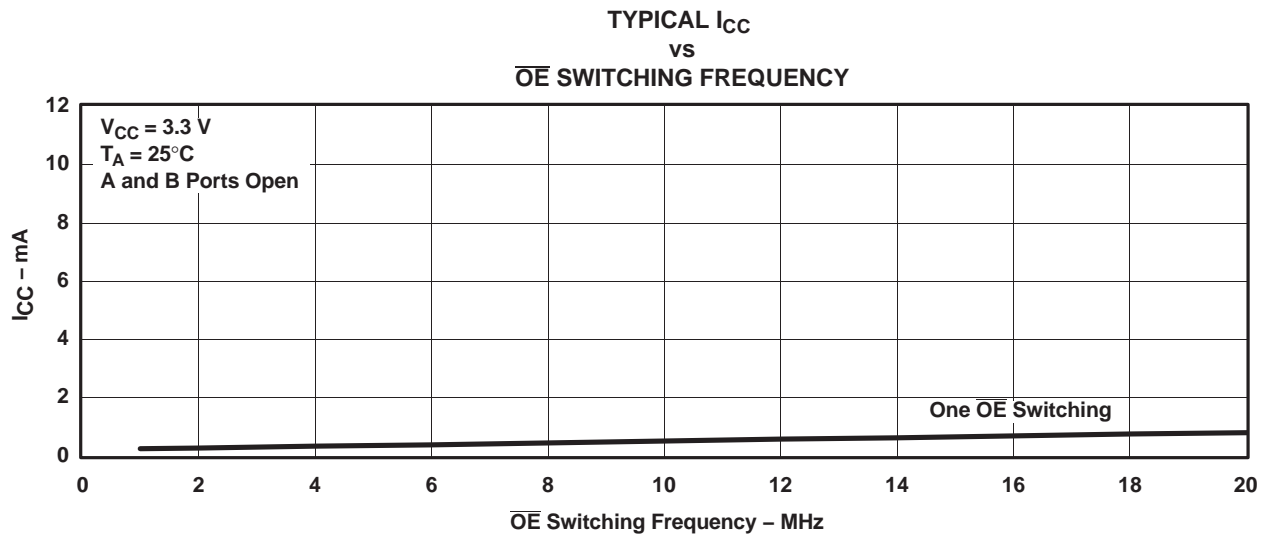
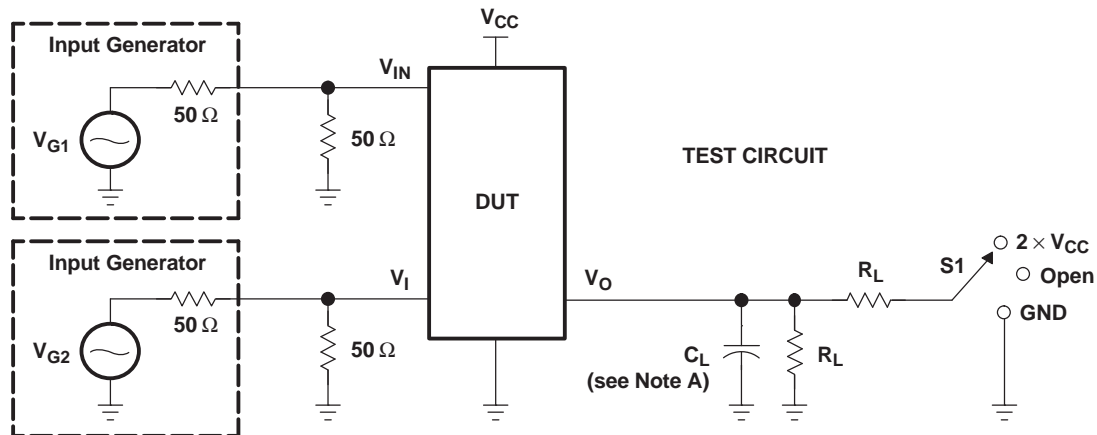
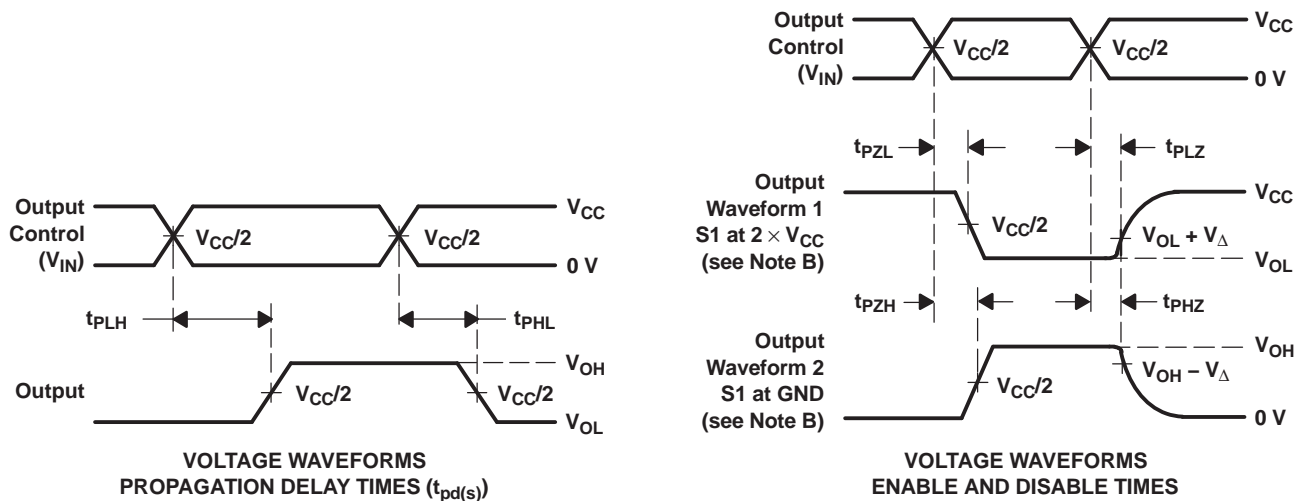

Figure 2. Typical  $I_{CC}$  vs  $\overline{OE}$  Switching Frequency

**PARAMETER MEASUREMENT INFORMATION**

TEST	V <sub>CC</sub>	S1	R <sub>L</sub>	V <sub>I</sub>	C <sub>L</sub>	V <sub>Δ</sub>
t <sub>pd(s)</sub>	2.5 V ± 0.2 V	Open	500 Ω	V <sub>CC</sub> or GND	30 pF	
	3.3 V ± 0.3 V	Open	500 Ω	V <sub>CC</sub> or GND	50 pF	
t <sub>PLZ</sub> /t <sub>PZL</sub>	2.5 V ± 0.2 V	2 × V <sub>CC</sub>	500 Ω	GND	30 pF	0.15 V
	3.3 V ± 0.3 V	2 × V <sub>CC</sub>	500 Ω	GND	50 pF	0.3 V
t <sub>PHZ</sub> /t <sub>PZH</sub>	2.5 V ± 0.2 V	GND	500 Ω	V <sub>CC</sub>	30 pF	0.15 V
	3.3 V ± 0.3 V	GND	500 Ω	V <sub>CC</sub>	50 pF	0.3 V



- NOTES:
- C<sub>L</sub> includes probe and jig capacitance.
  - Waveform 1 is for an output with internal conditions such that the output is low, except when disabled by the output control. Waveform 2 is for an output with internal conditions such that the output is high, except when disabled by the output control.
  - All input pulses are supplied by generators having the following characteristics: PRR ≤ 10 MHz, Z<sub>O</sub> = 50 Ω, t<sub>r</sub> ≤ 2.5 ns, t<sub>f</sub> ≤ 2.5 ns.
  - The outputs are measured one at a time, with one transition per measurement.
  - t<sub>PLZ</sub> and t<sub>PHZ</sub> are the same as t<sub>dis</sub>.
  - t<sub>PZL</sub> and t<sub>PZH</sub> are the same as t<sub>en</sub>.
  - t<sub>PLH</sub> and t<sub>PHL</sub> are the same as t<sub>pd(s)</sub>. The t<sub>pd</sub> propagation delay is the calculated RC time constant of the typical ON-state resistance of the switch and the specified load capacitance, when driven by an ideal voltage source (zero output impedance).
  - All parameters and waveforms are not applicable to all devices.

**Figure 3. Test Circuit and Voltage Waveforms**

---

## REVISION HISTORY

Changes from Revision D (April 2005) to Revision E	Page
• Added DCU package ordering information. ....	1

---

**PACKAGING INFORMATION**

Orderable Device	Status (1)	Package Type	Package Drawing	Pins	Package Qty	Eco Plan (2)	Lead/Ball Finish (6)	MSL Peak Temp (3)	Op Temp (°C)	Device Marking (4/5)	Samples
74CB3Q3306ADCURE4	ACTIVE	VSSOP	DCU	8	3000	Green (RoHS & no Sb/Br)	CU NIPDAU	Level-1-260C-UNLIM	-40 to 85	GA6R	<a href="#">Samples</a>
74CB3Q3306ADCURG4	ACTIVE	VSSOP	DCU	8	3000	Green (RoHS & no Sb/Br)	CU NIPDAU	Level-1-260C-UNLIM	-40 to 85	GA6R	<a href="#">Samples</a>
SN74CB3Q3306ADCUR	ACTIVE	VSSOP	DCU	8	3000	Green (RoHS & no Sb/Br)	CU NIPDAU   CU SN	Level-1-260C-UNLIM	-40 to 85	(A6 ~ GA6Q ~ GA6R) GZ	<a href="#">Samples</a>
SN74CB3Q3306APW	ACTIVE	TSSOP	PW	8	150	Green (RoHS & no Sb/Br)	CU NIPDAU	Level-1-260C-UNLIM	-40 to 85	BU306A	<a href="#">Samples</a>
SN74CB3Q3306APWR	ACTIVE	TSSOP	PW	8	2000	Green (RoHS & no Sb/Br)	CU NIPDAU   CU SN	Level-1-260C-UNLIM	-40 to 85	BU306A	<a href="#">Samples</a>
SN74CB3Q3306APWRG4	ACTIVE	TSSOP	PW	8	2000	Green (RoHS & no Sb/Br)	CU NIPDAU	Level-1-260C-UNLIM	-40 to 85	BU306A	<a href="#">Samples</a>

(1) The marketing status values are defined as follows:

**ACTIVE:** Product device recommended for new designs.

**LIFEBUY:** TI has announced that the device will be discontinued, and a lifetime-buy period is in effect.

**NRND:** Not recommended for new designs. Device is in production to support existing customers, but TI does not recommend using this part in a new design.

**PREVIEW:** Device has been announced but is not in production. Samples may or may not be available.

**OBSOLETE:** TI has discontinued the production of the device.

(2) Eco Plan - The planned eco-friendly classification: Pb-Free (RoHS), Pb-Free (RoHS Exempt), or Green (RoHS & no Sb/Br) - please check <http://www.ti.com/productcontent> for the latest availability information and additional product content details.

**TBD:** The Pb-Free/Green conversion plan has not been defined.

**Pb-Free (RoHS):** TI's terms "Lead-Free" or "Pb-Free" mean semiconductor products that are compatible with the current RoHS requirements for all 6 substances, including the requirement that lead not exceed 0.1% by weight in homogeneous materials. Where designed to be soldered at high temperatures, TI Pb-Free products are suitable for use in specified lead-free processes.

**Pb-Free (RoHS Exempt):** This component has a RoHS exemption for either 1) lead-based flip-chip solder bumps used between the die and package, or 2) lead-based die adhesive used between the die and leadframe. The component is otherwise considered Pb-Free (RoHS compatible) as defined above.

**Green (RoHS & no Sb/Br):** TI defines "Green" to mean Pb-Free (RoHS compatible), and free of Bromine (Br) and Antimony (Sb) based flame retardants (Br or Sb do not exceed 0.1% by weight in homogeneous material)

(3) MSL, Peak Temp. - The Moisture Sensitivity Level rating according to the JEDEC industry standard classifications, and peak solder temperature.

(4) There may be additional marking, which relates to the logo, the lot trace code information, or the environmental category on the device.

(5) Multiple Device Markings will be inside parentheses. Only one Device Marking contained in parentheses and separated by a "~" will appear on a device. If a line is indented then it is a continuation of the previous line and the two combined represent the entire Device Marking for that device.

<sup>(6)</sup> Lead/Ball Finish - Orderable Devices may have multiple material finish options. Finish options are separated by a vertical ruled line. Lead/Ball Finish values may wrap to two lines if the finish value exceeds the maximum column width.

**Important Information and Disclaimer:** The information provided on this page represents TI's knowledge and belief as of the date that it is provided. TI bases its knowledge and belief on information provided by third parties, and makes no representation or warranty as to the accuracy of such information. Efforts are underway to better integrate information from third parties. TI has taken and continues to take reasonable steps to provide representative and accurate information but may not have conducted destructive testing or chemical analysis on incoming materials and chemicals. TI and TI suppliers consider certain information to be proprietary, and thus CAS numbers and other limited information may not be available for release.

In no event shall TI's liability arising out of such information exceed the total purchase price of the TI part(s) at issue in this document sold by TI to Customer on an annual basis.

**OTHER QUALIFIED VERSIONS OF SN74CB3Q3306A :**

- Enhanced Product: [SN74CB3Q3306A-EP](#)

NOTE: Qualified Version Definitions:

- Enhanced Product - Supports Defense, Aerospace and Medical Applications

**TAPE AND REEL INFORMATION**

**QUADRANT ASSIGNMENTS FOR PIN 1 ORIENTATION IN TAPE**

\*All dimensions are nominal

Device	Package Type	Package Drawing	Pins	SPQ	Reel Diameter (mm)	Reel Width W1 (mm)	A0 (mm)	B0 (mm)	K0 (mm)	P1 (mm)	W (mm)	Pin1 Quadrant
74CB3Q3306ADCURG4	VSSOP	DCU	8	3000	180.0	8.4	2.25	3.35	1.05	4.0	8.0	Q3
SN74CB3Q3306ADCUR	VSSOP	DCU	8	3000	180.0	8.4	2.25	3.35	1.05	4.0	8.0	Q3
SN74CB3Q3306ADCUR	VSSOP	DCU	8	3000	180.0	9.0	2.05	3.3	1.0	4.0	8.0	Q3
SN74CB3Q3306APWR	TSSOP	PW	8	2000	330.0	12.4	7.0	3.6	1.6	8.0	12.0	Q1
SN74CB3Q3306APWR	TSSOP	PW	8	2000	330.0	12.4	7.0	3.6	1.6	8.0	12.0	Q1
SN74CB3Q3306APWRG4	TSSOP	PW	8	2000	330.0	12.4	7.0	3.6	1.6	8.0	12.0	Q1

**TAPE AND REEL BOX DIMENSIONS**

\*All dimensions are nominal

Device	Package Type	Package Drawing	Pins	SPQ	Length (mm)	Width (mm)	Height (mm)
74CB3Q3306ADCURG4	VSSOP	DCU	8	3000	202.0	201.0	28.0
SN74CB3Q3306ADCUR	VSSOP	DCU	8	3000	202.0	201.0	28.0
SN74CB3Q3306ADCUR	VSSOP	DCU	8	3000	182.0	182.0	20.0
SN74CB3Q3306APWR	TSSOP	PW	8	2000	367.0	367.0	35.0
SN74CB3Q3306APWR	TSSOP	PW	8	2000	364.0	364.0	27.0
SN74CB3Q3306APWRG4	TSSOP	PW	8	2000	367.0	367.0	35.0



DCU (S-PDSO-G8)

PLASTIC SMALL OUTLINE PACKAGE (DIE DOWN)



- NOTES:
- A. All linear dimensions are in millimeters.
  - B. This drawing is subject to change without notice.
  - C. Publication IPC-7351 is recommended for alternate designs.
  - D. Laser cutting apertures with trapezoidal walls and also rounding corners will offer better paste release. Customers should contact their board assembly site for stencil design recommendations. Refer to IPC-7525 for other stencil recommendations.
  - E. Customers should contact their board fabrication site for solder mask tolerances between and around signal pads.

PW0008A



PACKAGE OUTLINE  
TSSOP - 1.2 mm max height

SMALL OUTLINE PACKAGE

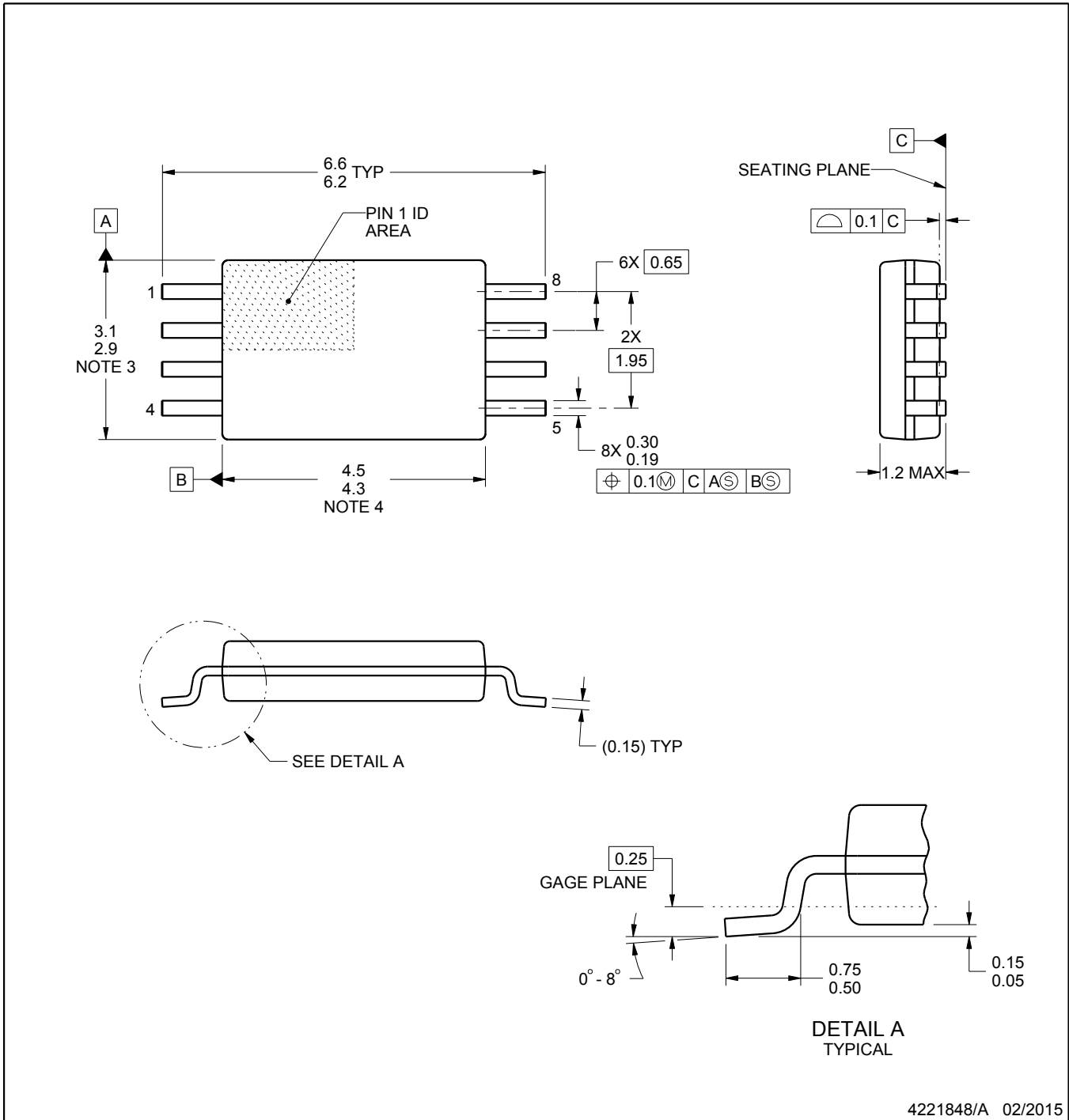

4221848/A 02/2015

NOTES:

1. All linear dimensions are in millimeters. Any dimensions in parenthesis are for reference only. Dimensioning and tolerancing per ASME Y14.5M.
2. This drawing is subject to change without notice.
3. This dimension does not include mold flash, protrusions, or gate burrs. Mold flash, protrusions, or gate burrs shall not exceed 0.15 mm per side.
4. This dimension does not include interlead flash. Interlead flash shall not exceed 0.25 mm per side.
5. Reference JEDEC registration MO-153, variation AA.

# EXAMPLE BOARD LAYOUT

PW0008A

TSSOP - 1.2 mm max height

SMALL OUTLINE PACKAGE

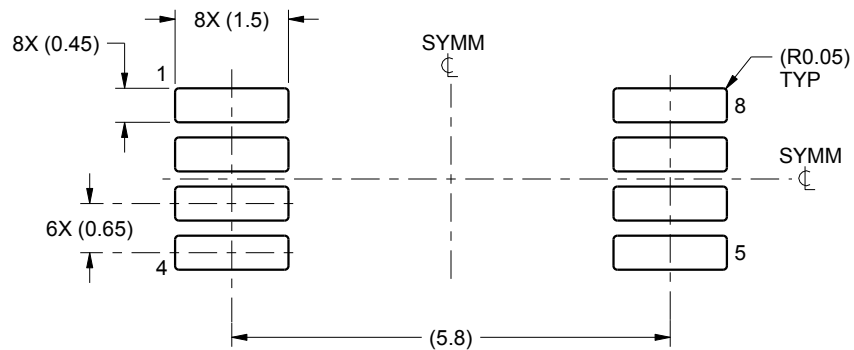

LAND PATTERN EXAMPLE  
SCALE:10X

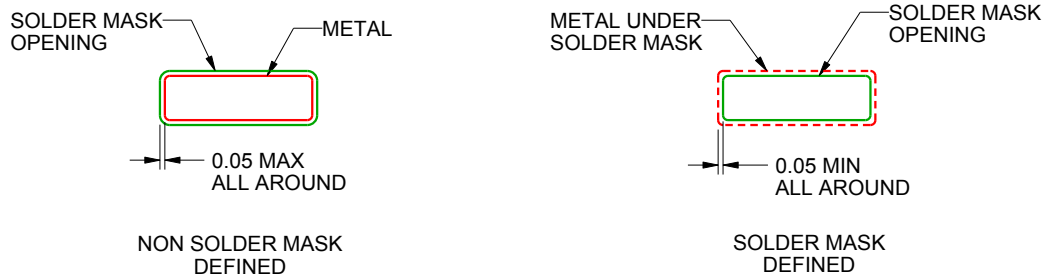

SOLDER MASK DETAILS  
NOT TO SCALE

4221848/A 02/2015

NOTES: (continued)

- 6. Publication IPC-7351 may have alternate designs.
- 7. Solder mask tolerances between and around signal pads can vary based on board fabrication site.

# EXAMPLE STENCIL DESIGN

PW0008A

TSSOP - 1.2 mm max height

SMALL OUTLINE PACKAGE



SOLDER PASTE EXAMPLE  
BASED ON 0.125 mm THICK STENCIL  
SCALE:10X

4221848/A 02/2015

NOTES: (continued)

8. Laser cutting apertures with trapezoidal walls and rounded corners may offer better paste release. IPC-7525 may have alternate design recommendations.
9. Board assembly site may have different recommendations for stencil design.

## IMPORTANT NOTICE AND DISCLAIMER

TI PROVIDES TECHNICAL AND RELIABILITY DATA (INCLUDING DATASHEETS), DESIGN RESOURCES (INCLUDING REFERENCE DESIGNS), APPLICATION OR OTHER DESIGN ADVICE, WEB TOOLS, SAFETY INFORMATION, AND OTHER RESOURCES "AS IS" AND WITH ALL FAULTS, AND DISCLAIMS ALL WARRANTIES, EXPRESS AND IMPLIED, INCLUDING WITHOUT LIMITATION ANY IMPLIED WARRANTIES OF MERCHANTABILITY, FITNESS FOR A PARTICULAR PURPOSE OR NON-INFRINGEMENT OF THIRD PARTY INTELLECTUAL PROPERTY RIGHTS.

These resources are intended for skilled developers designing with TI products. You are solely responsible for (1) selecting the appropriate TI products for your application, (2) designing, validating and testing your application, and (3) ensuring your application meets applicable standards, and any other safety, security, or other requirements. These resources are subject to change without notice. TI grants you permission to use these resources only for development of an application that uses the TI products described in the resource. Other reproduction and display of these resources is prohibited. No license is granted to any other TI intellectual property right or to any third party intellectual property right. TI disclaims responsibility for, and you will fully indemnify TI and its representatives against, any claims, damages, costs, losses, and liabilities arising out of your use of these resources.

TI's products are provided subject to TI's Terms of Sale ([www.ti.com/legal/termsofsale.html](http://www.ti.com/legal/termsofsale.html)) or other applicable terms available either on [ti.com](http://ti.com) or provided in conjunction with such TI products. TI's provision of these resources does not expand or otherwise alter TI's applicable warranties or warranty disclaimers for TI products.

Mailing Address: Texas Instruments, Post Office Box 655303, Dallas, Texas 75265  
Copyright © 2019, Texas Instruments Incorporated

## Looking for pricing, stock, or lifecycle information?

Click below to explore more details on WIN SOURCE:

 [View SN74CB3Q3306APWG4 on WIN SOURCE](#)

 [Texas Instruments](#) Information

## Optimize Your Supply Chain with WIN SOURCE Solutions

-  Global Sourcing Solution
-  Obsolete Management
-  Cost Control Management
-  Shortage Management
-  Alternative Solution
-  Excess Inventory Management