

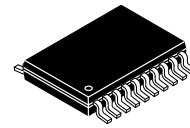


**THE DATASHEET OF  
NB3N853531EDTR2G**



# 3.3 V Xtal or LVTTTL/LVCMOS Input 2:1 MUX to 1:4 LVPECL Fanout Buffer

## NB3N853531E



TSSOP-20  
DT SUFFIX  
CASE 948E

### Description

The NB3N853531E is a low skew 3.3 V supply 1:4 clock distribution fanout buffer. An input MUX selects either a Fundamental Parallel Mode Crystal or a LVCMOS/LVTTL Clock by using the CLK\_SEL pin (HIGH for Crystal, LOW for Clock) with LVCMOS / LVTTL levels.

The single ended CLK input is translated to four LVPECL Outputs. Using the crystal input, the NB3N853531E can be a Clock Generator. A CLK\_EN pin can enable or disable the outputs synchronously to eliminate runt pulses using LVCMOS/LVTTL levels (HIGH to enable outputs, LOW to disable outputs).

### Features

- Four Differential 3.3 V LVPECL Outputs
- Selectable Crystal or LVCMOS/LVTTL CLOCK Inputs
- Up to 266 MHz Clock Operation
- Output to Output Skew: 30 ps (Max)
- Device to Device Skew 200 ps (Max)
- Propagation Delay 1.8 ns (Max)
- Operating Range:  $V_{CC} = 3.3 \pm 5\% V$  (3.135 to 3.465 V)
- Additive Phase Jitter, RMS: 0.053 ps (Typ)
- Synchronous Clock Enable Control
- Industrial Temp. Range (-40°C to 85°C)
- Pb-Free TSSOP-20 Package
- Ambient Operating Temperature Range -40°C to +85°C
- These Devices are Pb-Free and are RoHs Compliant

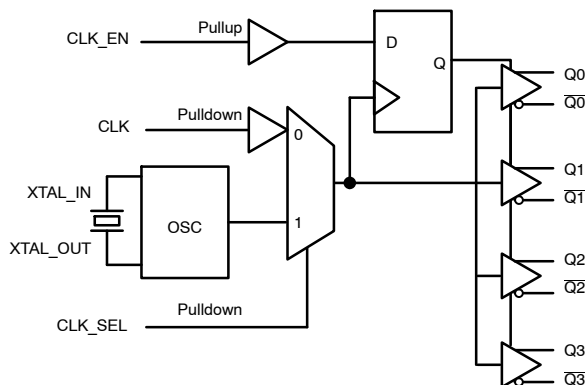
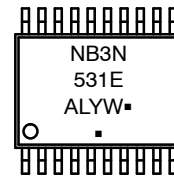


Figure 1. Simplified Logic Diagram

### MARKING DIAGRAM



- A = Assembly Location
- L = Wafer Lot
- Y = Year
- W = Work Week
- = Pb-Free Package

(Note: Microdot may be in either location)

### ORDERING INFORMATION

Device	Package	Shipping†
NB3N853531EDTR2G	TSSOP-20 (Pb-Free)	2500 / Tape & Reel

†For information on tape and reel specifications, including part orientation and tape sizes, please refer to our Tape and Reel Packaging Specification Brochure, [BRD8011/D](#).

# NB3N853531E

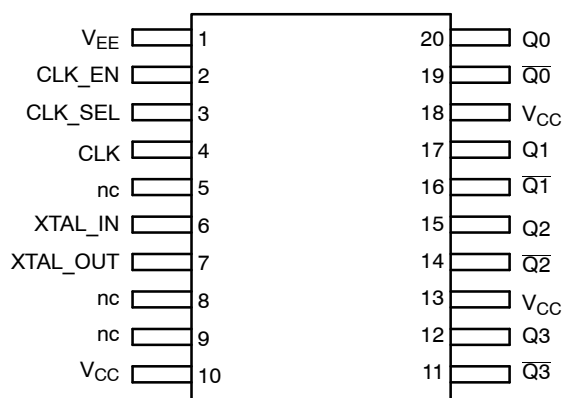


Figure 2. Pinout Diagram (Top View)

Table 1. PIN DESCRIPTION

Pin	Name	I/O	Open Default	Description
1	V <sub>EE</sub>			Negative (Ground) Power Supply pin must be externally connected to power supply to guarantee proper operation.
2	CLK_EN	LVC MOS / LV TTL	Pullup	Synchronized Clock Enable when HIGH. When LOW, outputs are disabled (Qx HIGH, Q <sub>x</sub> LOW)
3	CLK_SEL	LVC MOS / LV TTL	Pulldown	Clock Input Select (HIGH selects crystal, LOW selects CLK input)
4	CLK	LVC MOS / LV TTL	Pulldown	Clock Input. Float open when unused.
5, 8, 9	nc			No Connect
6	XTAL_IN	Crystal		Crystal Oscillator Input (used with pin 7). Float open when unused.
7	XTAL_OUT	Crystal		Crystal Oscillator Output (used with pin 6). Float open when unused.
10, 13, 18	V <sub>CC</sub>			Positive Power Supply pins must be externally connected to power supply to guarantee proper operation.
11, 14, 16, 19	Q[3:0]	LVPECL		Complement Differential Outputs (See <a href="#">AND8002/D</a> for termination)
12, 15, 17, 20	Q[3:0]	LVPECL		True Differential Outputs (See <a href="#">AND8002/D</a> for termination)

Table 2. FUNCTIONS

Inputs			Outputs		
CLK_EN	CLK_SEL	Input Function	Output Function	Q <sub>x</sub>	Q <sub>x</sub> -bar
0	0	CLK input selected	Disabled	LOW	HIGH
0	1	Crystal Inputs Selected	Disabled	LOW	HIGH
1	0	CLK input selected	Enabled	CLK0	Invert of CLK1
1	1	Crystal Inputs Selected	Enabled	CLK1	Invert of CLK1

1. After CLK\_EN switches, the clock outputs are disabled or enabled following a rising and falling input clock edge as show in Figure 3.

# NB3N853531E

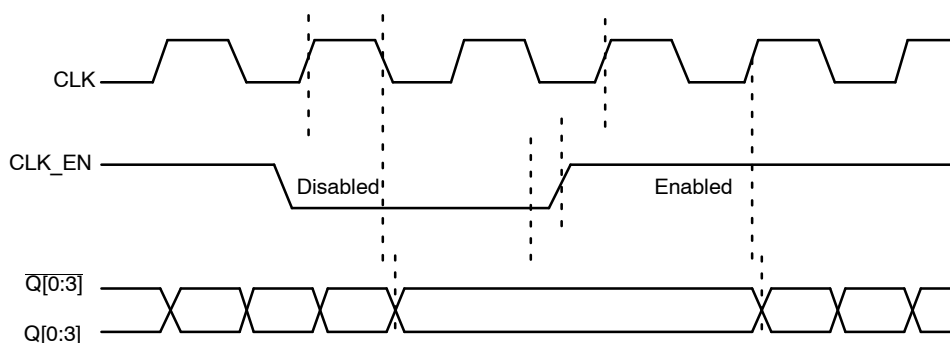


Figure 3. CLK\_EN Timing Diagram

Table 3. ATTRIBUTES (Note 2)

Characteristics	Value
Internal Input Pullup Resistor	50 k $\Omega$
Internal Input Pulldown Resistor	50 k $\Omega$
C <sub>in</sub> Input Capacitance	4 pF
ESD Protection Human Body Model Machine Model	> 2 kV > 200 V
Moisture Sensitivity, Indefinite Time Out of Drypack (Note 2)	Level 1
Flammability Rating Oxygen Index	UL 94 V-0 @ 0.125 in 28 to 34
Transistor Count	333 Devices
Meets or exceeds JEDEC Spec EIA/JESD78 IC Latchup Test	

2. For additional information, see Application Note [AND8003/D](#).

Table 4. MAXIMUM RATINGS (Note 3)

Symbol	Parameter	Condition 1	Condition 2	Rating	Unit
V <sub>CC</sub>	Supply Voltage			4.6	V
V <sub>in</sub>	Input Voltage			-0.5 ≤ V <sub>I</sub> ≤ V <sub>CC</sub> + 0.5	V
I <sub>out</sub>	Output Current	Continuous Surge		50 100	mA
T <sub>A</sub>	Operating Temperature Range, Industrial			-40 to ≤ +85	°C
T <sub>stg</sub>	Storage Temperature Range			-65 to +150	°C
θ <sub>JA</sub>	Thermal Resistance (Junction-to-Ambient)	0 lfpm	Single-Layer PCB (700 mm <sup>2</sup> , 2 oz)	128	°C/W
		200 lfpm	Multi-Layer PCB (700 mm <sup>2</sup> , 2 oz)	94	
θ <sub>JC</sub>	Thermal Resistance (Junction-to-Case)	(Note 4)	TSSOP-20	23 to 41	°C/W
T <sub>sol</sub>	Wave Solder			265	°C

Stresses exceeding those listed in the Maximum Ratings table may damage the device. If any of these limits are exceeded, device functionality should not be assumed, damage may occur and reliability may be affected.

3. Maximum ratings applied to the device are individual stress limit values (not normal operating conditions) and not valid simultaneously.

If stress limits are exceeded device functional operation is not implied, damage may occur and reliability may be affected.

4. JEDEC standard multilayer board – 2S2P (2 signal, 2 power).

# NB3N853531E

**Table 5. CRYSTAL CHARACTERISTICS AND CONNECTIONS**

Parameter	Min	Typ	Max	Unit
Mode of Oscillation	Fundamental Parallel			
Frequency	12		40	MHz
Equivalent Series Resistance (ESR)			50	$\Omega$
Shunt Capacitance			7	pF
Drive Level			1	mW

**Table 6. DC CHARACTERISTICS**  $V_{CC} = 3.3 \pm 5\% V$  (3.135 to 3.465 V),  $V_{EE} = 0 V$ ,  $T_A = -40^\circ C$  to  $+85^\circ C$  (Note 5)

Symbol	Characteristic	Min	Typ	Max	Unit
$I_{EE}$	Power Supply Current			60	mA
$V_{IH}$	Input HIGH Voltage	2		$V_{CC} + 0.3$	V
$V_{IL}$	Input LOW Voltage	-0.3		0.8	V
$I_{IH}$	Input High Current ( $V_{CC} = 3.456 V$ ) CLK, CLK_SEL = 3.456 V CLK_EN = 3.456 V			150 5	$\mu A$
$I_{IL}$	Input LOW Current ( $V_{CC} = 3.456 V$ ) CLK, CLK_SEL = 3.456 V CLK_EN = 3.456 V	-5 -150			$\mu A$
$V_{OH}$	Output HIGH Voltage	$V_{CC} - 1.4$		$V_{CC} - 0.9$	V
$V_{OL}$	Output LOW Voltage	$V_{CC} - 2.0$		$V_{CC} - 1.7$	V
$V_{OUT\_SWING}$	Output Voltage Swing (peak-to-peak)	0.6		1.0	V

NOTE: Device will meet the specifications after thermal equilibrium has been established when mounted in a test socket or printed circuit board with maintained transverse airflow greater than 500 lfp.m.

5. Outputs terminated 50  $\Omega$  to  $V_{CC} - 2.0 V$ , see Figure 4.

**Table 7. AC CHARACTERISTICS**  $V_{CC} = 3.3 \pm 5\% V$  (3.135 to 3.465 V),  $V_{EE} = 0 V$ ,  $T_A = -40^\circ C$  to  $+85^\circ C$  (Note 6)

Symbol	Characteristic	Min	Typ	Max	Unit
$F_{MAX}$	Maximum Operating Frequency	0		266	MHz
$t_{PD}$	Propagation Delay (Notes 7 and 9)	1.1		1.8	ns
$t_{SKEW\_DC}$	Duty Cycle Skew same path similar conditions at 50 MHz (Notes 7, 8 and 9)	46		54	%
$t_{SKEW\_O-O}$	Output to Output Skew Within A Device (Notes 7, 8 and 9)			30	ps
$t_{SKEW\_D-D}$	Device to Device Skew similar path and conditions (Notes 7, 8 and 9)			200	ps
$t_{JIT}$	Additive Phase Noise Jitter (RMS) @ 155.52 MHz (Integrated from 12 kHz to 20 MHz) See Figure 6. (Note 9)		0.053		ps
$t_r/t_f$	Output rise and fall times (20% and 80% points) (Note 9)	225		600	ps

NOTE: Device will meet the specifications after thermal equilibrium has been established when mounted in a test socket or printed circuit board with maintained transverse airflow greater than 500 lfp.m.

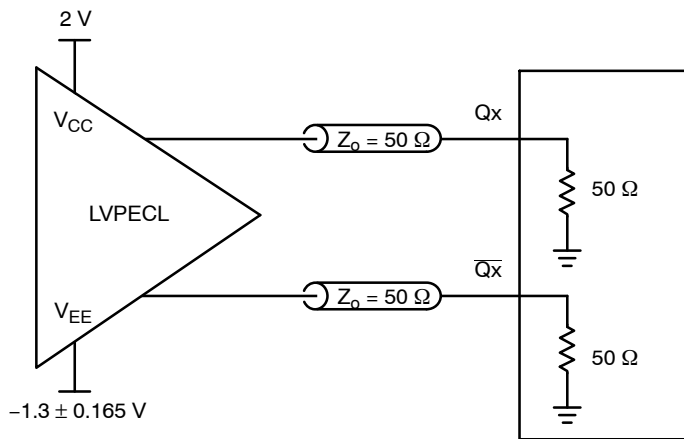
6. Outputs terminated 50  $\Omega$  to  $V_{CC} - 2.0 V$ , see Figure 4.

7. Measured under the same supply voltage, output loading, and input conditions.

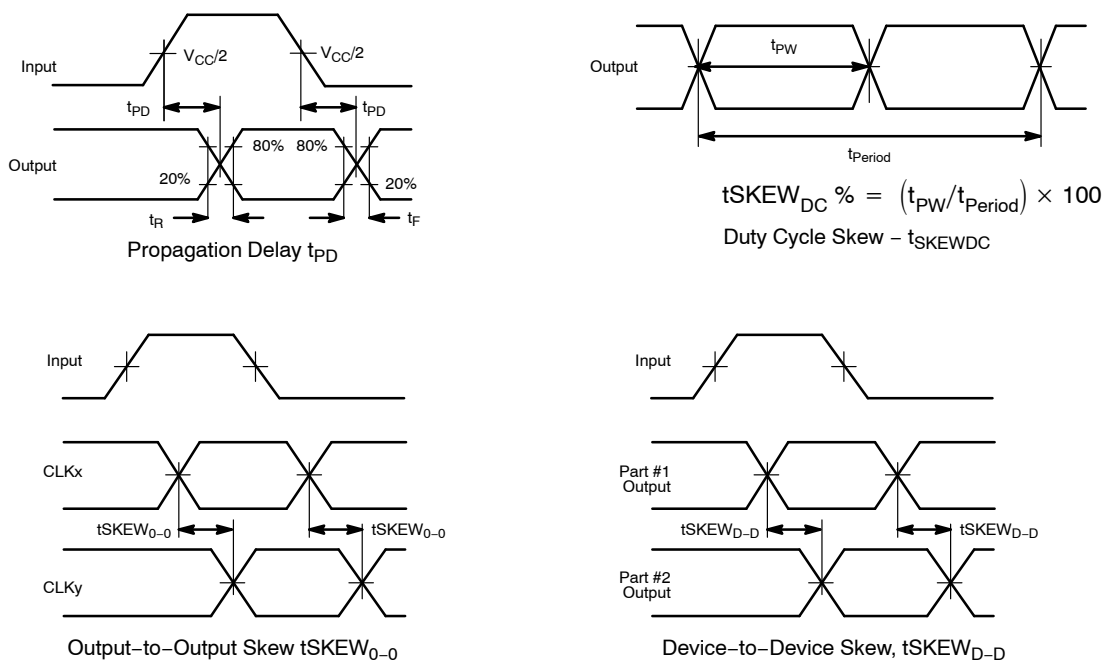
8. Similar conditions.

9. Limits do not apply to overdriving XTAL\_IN.

# NB3N853531E

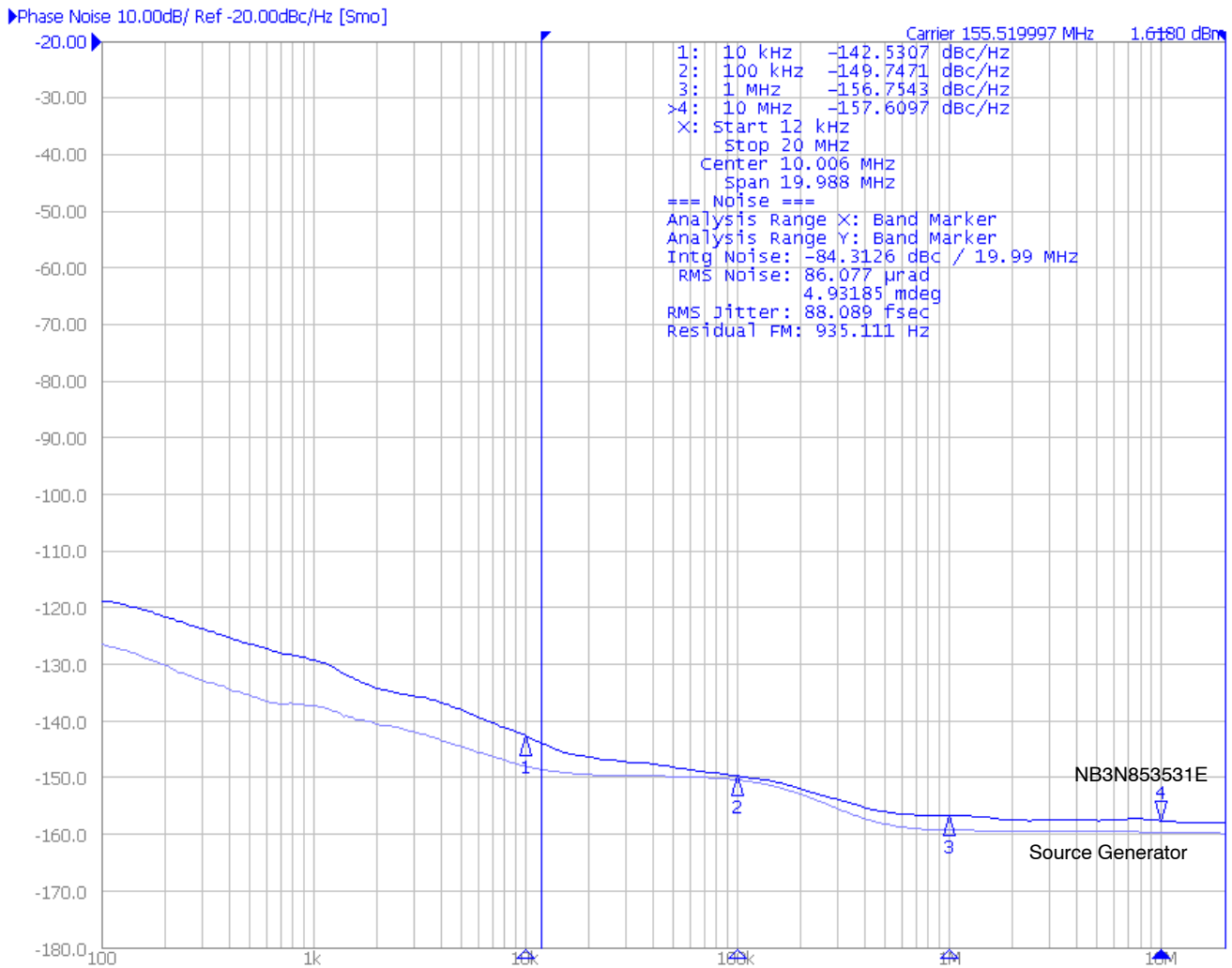


**Figure 4. Typical Test Setup and Termination for Evaluation. A split supply of  $V_{CC} = 2.0\text{ V}$  and  $V_{EE} = -1.3 \pm 0.165\text{ V}$  allows a convenient direct connection termination into typical oscilloscope  $50\ \Omega$  to GND impedance modules. For Application termination schemes see AND8020.**



**Figure 5. AC Measurement Reference**

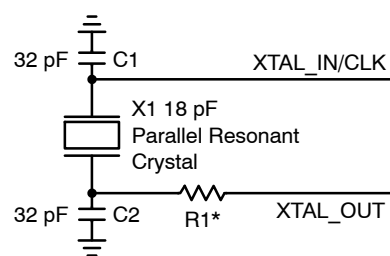
# NB3N853531E



**Figure 6. For 155.52 MHz Carrier, the NB3N853531E Additive Phase Noise (dBc/Hz) versus SSB Offset Frequency (Hz) Integrated Jitter from 12 kHz to 20 MHz (Upper Heavy Line) is 88.1 fs RMS. The E8663B Source Generator Additive Phase Noise (Lower Light Line) is 70.1 fs RMS. Where  $t_{JIT} = \sqrt{(t_{JIToutput})^2 - (t_{JITinput})^2} = 53$  fs**

## Application – Crystal Input Interface

Figure 7 shows the NB3N853531E device crystal oscillator interface using a typical parallel resonant crystal. A parallel crystal with loading capacitance  $C_L = 18$  pF could use Series Load Caps  $C1 = 32$  pF and  $C2 = 32$  pF as nominal values, after subtracting a typical 4 pF of stray cap per line. The frequency accuracy and duty cycle skew can be fine tuned by adjusting the  $C1$  and  $C2$  values. For example, increasing the  $C1$  and  $C2$  values will reduce the operational frequency. Note  $R1$  is optional and may be  $0 \Omega$ .



**Figure 7. NB3N853531E Crystal Oscillator Interface**  
 \* $R1$  is optional. Assuming 4 pF stray cap per pin.

# NB3N853531E

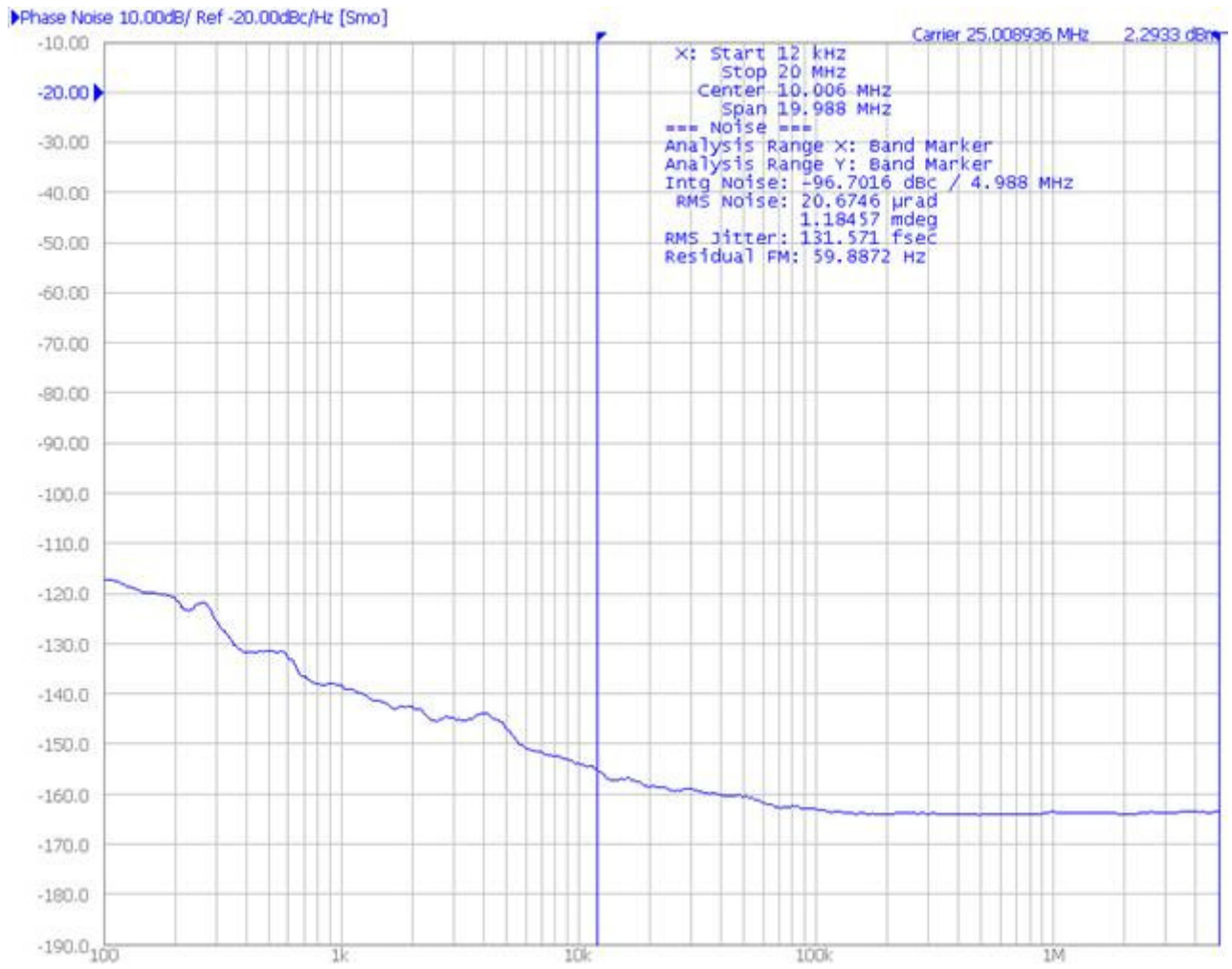


Figure 8. NB3N853531E Phase Noise with 25 MHz Crystal

# MECHANICAL CASE OUTLINE

## PACKAGE DIMENSIONS

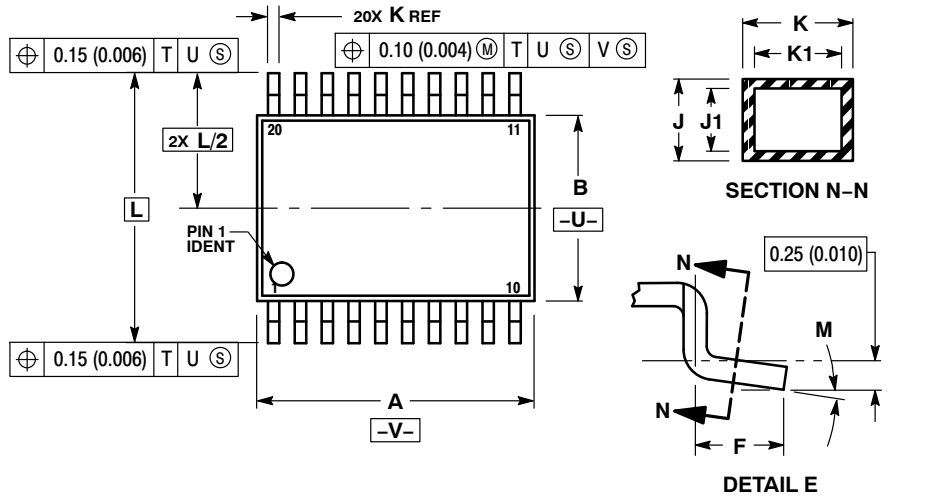
ON Semiconductor®



TSSOP-20 WB  
CASE 948E  
ISSUE D

DATE 17 FEB 2016

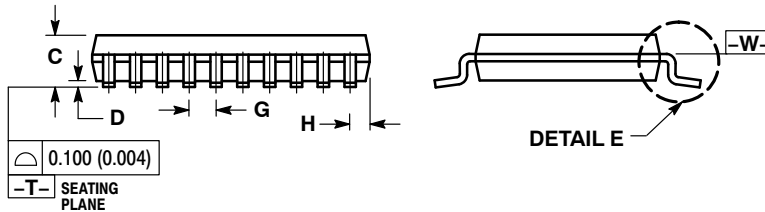
SCALE 2:1



NOTES:

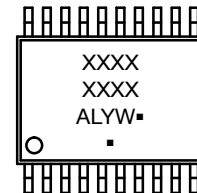
1. DIMENSIONING AND TOLERANCING PER ANSI Y14.5M, 1982.
2. CONTROLLING DIMENSION: MILLIMETER.
3. DIMENSION A DOES NOT INCLUDE MOLD FLASH, PROTRUSIONS OR GATE BURRS. MOLD FLASH OR GATE BURRS SHALL NOT EXCEED 0.15 (0.006) PER SIDE.
4. DIMENSION B DOES NOT INCLUDE INTERLEAD FLASH OR PROTRUSION. INTERLEAD FLASH OR PROTRUSION SHALL NOT EXCEED 0.25 (0.010) PER SIDE.
5. DIMENSION K DOES NOT INCLUDE DAMBAR PROTRUSION. ALLOWABLE DAMBAR PROTRUSION SHALL BE 0.08 (0.003) TOTAL IN EXCESS OF THE K DIMENSION AT MAXIMUM MATERIAL CONDITION.
6. TERMINAL NUMBERS ARE SHOWN FOR REFERENCE ONLY.
7. DIMENSION A AND B ARE TO BE DETERMINED AT DATUM PLANE -W-.

DIM	MILLIMETERS		INCHES	
	MIN	MAX	MIN	MAX
A	6.40	6.60	0.252	0.260
B	4.30	4.50	0.169	0.177
C	---	1.20	---	0.047
D	0.05	0.15	0.002	0.006
F	0.50	0.75	0.020	0.030
G	0.65 BSC		0.026 BSC	
H	0.27	0.37	0.011	0.015
J	0.09	0.20	0.004	0.008
J1	0.09	0.16	0.004	0.006
K	0.19	0.30	0.007	0.012
K1	0.19	0.25	0.007	0.010
L	6.40 BSC		0.252 BSC	
M	0°	8°	0°	8°



SOLDERING FOOTPRINT

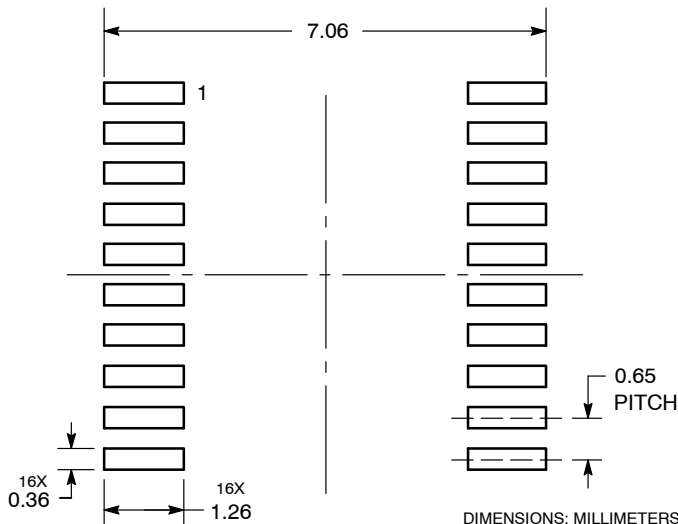
GENERIC MARKING DIAGRAM\*



- A = Assembly Location
- L = Wafer Lot
- Y = Year
- W = Work Week
- = Pb-Free Package

(Note: Microdot may be in either location)

\*This information is generic. Please refer to device data sheet for actual part marking. Pb-Free indicator, "G" or microdot "▪", may or may not be present.



DIMENSIONS: MILLIMETERS

DOCUMENT NUMBER:	98ASH70169A	Electronic versions are uncontrolled except when accessed directly from the Document Repository. Printed versions are uncontrolled except when stamped "CONTROLLED COPY" in red.
DESCRIPTION:	TSSOP-20 WB	PAGE 1 OF 1

ON Semiconductor and ON are trademarks of Semiconductor Components Industries, LLC dba ON Semiconductor or its subsidiaries in the United States and/or other countries. ON Semiconductor reserves the right to make changes without further notice to any products herein. ON Semiconductor makes no warranty, representation or guarantee regarding the suitability of its products for any particular purpose, nor does ON Semiconductor assume any liability arising out of the application or use of any product or circuit, and specifically disclaims any and all liability, including without limitation special, consequential or incidental damages. ON Semiconductor does not convey any license under its patent rights nor the rights of others.

**onsemi**, **Onsemi**, and other names, marks, and brands are registered and/or common law trademarks of Semiconductor Components Industries, LLC dba "**onsemi**" or its affiliates and/or subsidiaries in the United States and/or other countries. **onsemi** owns the rights to a number of patents, trademarks, copyrights, trade secrets, and other intellectual property. A listing of **onsemi**'s product/patent coverage may be accessed at [www.onsemi.com/site/pdf/Patent-Marking.pdf](http://www.onsemi.com/site/pdf/Patent-Marking.pdf). **onsemi** reserves the right to make changes at any time to any products or information herein, without notice. The information herein is provided "as-is" and **onsemi** makes no warranty, representation or guarantee regarding the accuracy of the information, product features, availability, functionality, or suitability of its products for any particular purpose, nor does **onsemi** assume any liability arising out of the application or use of any product or circuit, and specifically disclaims any and all liability, including without limitation special, consequential or incidental damages. Buyer is responsible for its products and applications using **onsemi** products, including compliance with all laws, regulations and safety requirements or standards, regardless of any support or applications information provided by **onsemi**. "Typical" parameters which may be provided in **onsemi** data sheets and/or specifications can and do vary in different applications and actual performance may vary over time. All operating parameters, including "Typicals" must be validated for each customer application by customer's technical experts. **onsemi** does not convey any license under any of its intellectual property rights nor the rights of others. **onsemi** products are not designed, intended, or authorized for use as a critical component in life support systems or any FDA Class 3 medical devices or medical devices with a same or similar classification in a foreign jurisdiction or any devices intended for implantation in the human body. Should Buyer purchase or use **onsemi** products for any such unintended or unauthorized application, Buyer shall indemnify and hold **onsemi** and its officers, employees, subsidiaries, affiliates, and distributors harmless against all claims, costs, damages, and expenses, and reasonable attorney fees arising out of, directly or indirectly, any claim of personal injury or death associated with such unintended or unauthorized use, even if such claim alleges that **onsemi** was negligent regarding the design or manufacture of the part. **onsemi** is an Equal Opportunity/Affirmative Action Employer. This literature is subject to all applicable copyright laws and is not for resale in any manner.

## ADDITIONAL INFORMATION

### TECHNICAL PUBLICATIONS:

Technical Library: [www.onsemi.com/design/resources/technical-documentation](http://www.onsemi.com/design/resources/technical-documentation)  
onsemi Website: [www.onsemi.com](http://www.onsemi.com)

### ONLINE SUPPORT: [www.onsemi.com/support](http://www.onsemi.com/support)

For additional information, please contact your local Sales Representative at [www.onsemi.com/support/sales](http://www.onsemi.com/support/sales)

## Looking for pricing, stock, or lifecycle information?

Click below to explore more details on WIN SOURCE:

 [View NB3N853531EDTR2G on WIN SOURCE](#)

 [ON Semiconductor](#) Information

## Optimize Your Supply Chain with WIN SOURCE Solutions

-  Global Sourcing Solution
-  Obsolete Management
-  Cost Control Management
-  Shortage Management
-  Alternative Solution
-  Excess Inventory Management