



**THE DATASHEET OF  
EV1340QI**





# Enpirion<sup>®</sup> Power Datasheet

## EV1340QI 5A PowerSoC

### Synchronous Highly Integrated DC-DC DDR2/3/4/QDR<sup>™</sup> Memory Termination And Low VIN Operation

## Description

The EV1340 is a Power System on a Chip (PowerSoC) DC to DC converter in a 54 pin QFN that is optimized for DDR2, DDR3, DDR4 and QDR<sup>™</sup> VTT applications. It requires a nominal 3.3V power supply (AVIN) for the controller, and an input supply (VDDQ) voltage range of 1.0V to 1.8V. It provides a tightly regulated and very stable output voltage (VTT) which tracks VDDQ while sinking and sourcing up to 5A of output current. In addition, the EV1340 is an excellent solution for general low  $V_{IN}$  applications where high efficiency is critical.

The EV1340 utilizes innovative circuit techniques, high-density circuit integrations and optimized switching frequency along with Altera Enpirion's proprietary inductor technology to deliver high-quality, ultra compact, non-isolated DC-DC conversion.

The complete power converter solution enhances productivity by offering greatly simplified board design, layout and manufacturing requirements.

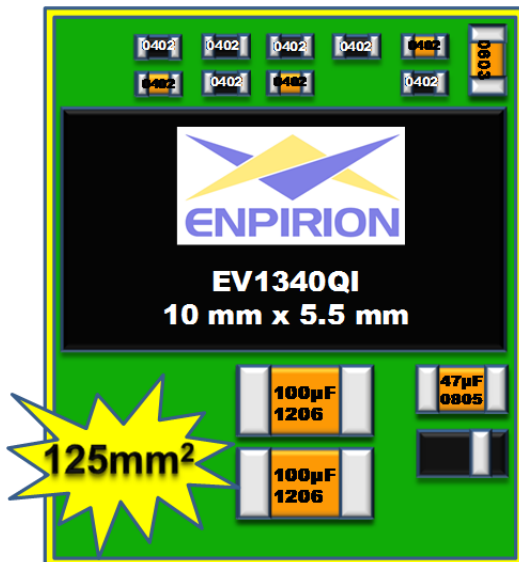

Figure 1: EV1340 Total Solution Size ~ 125mm<sup>2</sup> (not to scale)

## Features

- High Efficiency, Up to 91%
- Output Voltage Can Track VDDQ to within +/- 1.5%
- Source and Sink Capability up to 5A
- 125mm<sup>2</sup> Total Solution Size
- VDDQ Range (1.0V to 1.8V )
- Monotonic Startup With Pre-bias
- Programmable Soft-Start Time
- Thermal Shutdown Protection
- Over Current and Short Circuit Protection
- Under-Voltage Protection
- RoHS Compliant, MSL level 3, 260°C reflow

## Applications

- Bus Termination: DDR2, DDR3, DDR4 & QDR<sup>™</sup> Memory
- General Low  $V_{IN}$  Applications

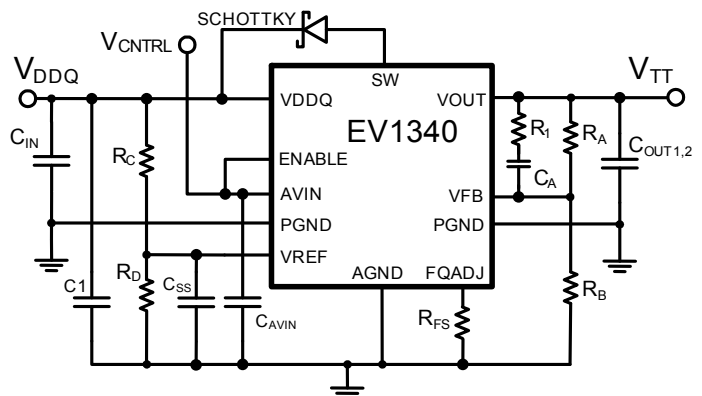
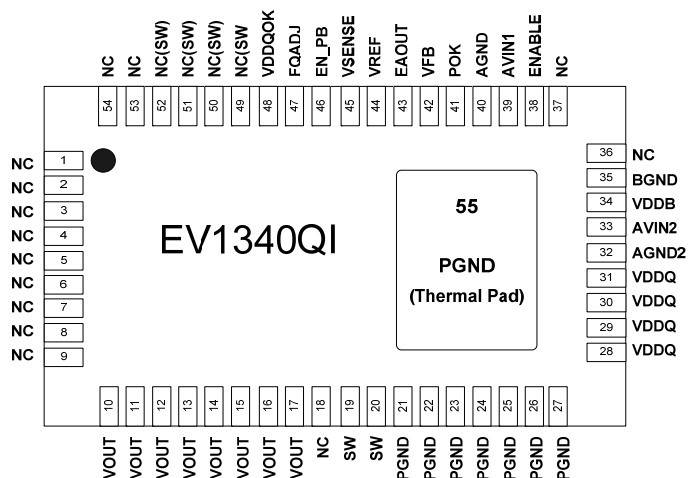

Figure 2: Typical VTT Application Schematic ( $V_{DDQ}$  is the memory core voltage;  $V_{TT}$  is memory termination voltage that tracks  $V_{DDQ}$ )

## Ordering Information

Part Number	Temp Rating (°C)	Package
EV1340QI	-40 to +85	54-pin QFN T&R
EVB-EV1340QI	QFN Evaluation Board	

## Pin Assignments (Top View)



**Figure 3: Pinout Diagram (Top View).**  
All pins must be soldered to PCB

**NOTE:** There are specific keep-out areas underneath the EV1340 to consider when laying out a PCB for this device. Please see Figures 8, 10, and 11 for more layout details.

## Pin Description

PIN	NAME	FUNCTION
1-9, 18, 36, 37, 53, 54	NC	NO CONNECT: These pins must be soldered to PCB but not electrically connected to each other or to any external signal, voltage, or ground. These pins may be connected internally. Failure to follow this guideline may result in device damage.
10 -17	VOUT	Regulated converter output. Decouple with output filter capacitor to PGND. Refer to layout section for specific layout requirements
19, 20,	SW	These pins are internally connected to the common switching node of the internal MOSFETs. The anode of a Schottky diode needs to be connected to these pins. The cathode of the diode needs to be connected to VDDQ.
21-27	PGND	Input and output power ground. Refer to layout section for specific layout requirements.
28-31	VDDQ	In DDR applications the input to this pin is the DDR core voltage. This is the input power supply to the power train which will be divided by two to create an output voltage that tracks with the input voltage applied to this pin. Decouple with input capacitor to PGND. Refer to layout section for specific layout requirements
32	AGND2	Ground for the gate driver supply. Connect to the GND plane with a via next to the pin.
33, 39	AVIN1, AVIN2	Analog input voltage for the controller circuits. Each of these pins needs to be separately connected to the 3.3V input supply. Decouple with a capacitor to AGND.
34	VDDB	Internal regulated voltage used for the internal control circuitry. This pin is reserved for Altera Enpirion testing, and should be left floating.
35	BGND	This pin is reserved for Altera Enpirion testing, and should be left floating.
38	ENABLE	This is the Device Enable pin. Floating this pin or a high level enables the device while a low level disables the device.
40	AGND	This is the quiet ground for the controller. Connect to the GND plane with a via next to the pin.
41	POK	POK is a logical AND of VDDQOK and the internally generated POK of the EV1340. POK is an open drain logic output that requires an external pull-up resistor. This pin guarantees a logic low even when the EV1340 is completely un-powered. This pin can sink a maximum 4mA. The pull-up resistor may be connected to a power supply other than AVIN or VDDQ but the voltage should be <3.6Volts.
42	VFB	This is the feedback input pin which is always active. A resistor divider connects from the output to AGND. The mid-point of the resistor divider is connected to VFB. (A feed-forward capacitor and a resistor are required across the upper resistor.) The output voltage regulates so as to make the VFB node voltage = 600mV.

PIN	NAME	FUNCTION
43	EAOUT	Optional Error Amplifier Output. Allows for customization of the control loop.
44	VREF	External voltage reference input. A resistor divider connects from VDDQ to AGND. The mid-point of the resistor divider is connected to VREF. The resistor divider has to be chosen to make the voltage applied to this pin 600mV. An optional capacitor (for soft-start) may be connected from VREF to AGND.
45	VSENSE	This pin senses the output voltage when the device is in pre-bias (or backfeed) mode. Connect to VOUT if EN_PB is high. Leave this pin floating if EN_PB is pulled to GND.
46	EN_PB	Monotonic start-up with pre-bias is enabled by either pulling this pin high or letting it float. A logical low on this pin will disable pre-bias mode operation.
47	FQADJ	Optimized frequency adjust pin. Connect a 3.57k $\Omega$ resistor from this pin to AGND to optimize on switching frequency.
48	VDDQOK	This is an active high input pin that indicates the externally supplied VDDQ input has reached its POK level. This pin should be tied to the VDDQ regulator POK output. It has an internal pull-up, and can be left floating if not needed.
49-52	NC(SW)	No Connect – these pins are internally connected to the common switching node of the internal MOSFETs. They are not to be electrically connected to any external signal, ground, or voltage. Failure to follow these guidelines may result in damage to the device.
55	Thermal Pad (PGND)	Not a perimeter pin. Device thermal pad and PGND. Connected to the system ground plane. See Layout Recommendations section.

## Absolute Maximum Ratings

**CAUTION:** Absolute Maximum ratings are stress ratings only. Functional operation beyond the recommended operating conditions is not implied. Stress beyond the absolute maximum ratings may impair device life. Exposure to absolute maximum rated conditions for extended periods may affect device reliability.

PARAMETER	SYMBOL	MIN	MAX	UNITS
Input Supply Voltage: AVIN1, AVIN2	$V_{IN}$	-0.5	4.0	V
Voltages on: ENABLE, EN_PB, VDDQOK		-0.5	$V_{IN}$	V
Voltages on: VFB, VREF, EAOUT, VDDQ, VOUT, VSENSE, FQADJ		-0.5	2.7	V
Voltage on: POK			3.6	V
Voltage on: SW		-0.5	VDDQ+0.5	V
Storage Temperature Range	$T_{STG}$	-65	150	°C
Maximum Operating Junction Temperature	$T_{J-ABS Max}$		150	°C
Reflow Temp, 10 Sec, MSL3 JEDEC J-STD-020A			260	°C
ESD Rating (based on Human Body Model)			2000	V
ESD Rating (based on CDM)			500	V

## Recommended Operating Conditions

PARAMETER	SYMBOL	MIN	MAX	UNITS
Input Voltage Range: AVIN1, AVIN2		2.9	3.7	V
Input Voltage Range: VDDQ		1.0	1.8	V
Input Voltage Range: VREF	$V_{EXTREF}$	0.4	0.72	V
EN_PB, VDDQOK, EN		0	AVIN	V
Operating Ambient Temperature	$T_A$	-40	+85	°C
Operating Junction Temperature	$T_J$	-40	+125	°C

## Thermal Characteristics

PARAMETER	SYMBOL	TYP	UNITS
Thermal Resistance: Junction to Ambient (0 LFM) ( <b>Note 1</b> )	$\theta_{JA}$	22	°C/W
Thermal Resistance: Junction to Case (0 LFM)	$\theta_{JC}$	2	°C/W
Thermal Shutdown	$T_{SD}$	150	°C
Thermal Shutdown Hysteresis	$T_{SDH}$	20	°C

**Note 1:** Based on 2oz. external copper layers and proper thermal design in line with EIA/JEDEC JESD51-7 standard for high thermal conductivity boards.

## Electrical Characteristics

NOTE: AVIN1, AVIN2 = 3.3V, over operating temperature range unless otherwise noted. Typical values are at  $T_A = 25^\circ\text{C}$ .

PARAMETER	SYMBOL	TEST CONDITIONS	MIN	TYP	MAX	UNITS
Input Power Supply Voltage	VDDQ		1.0		1.8	V
Controller Supply Voltage	AVIN		2.9	3.3	3.7	V
Under Voltage Lock-out – AVIN Rising	$V_{UVLOR}$	Voltage above which UVLO is not asserted		2.3		V
Under Voltage Lock-out – AVIN Falling	$V_{UVLOF}$	Voltage below which UVLO is asserted		2.1		V
Controller Input Current	I <sub>AVIN</sub>	AVIN = 3.3V		12	20	mA
Shut-Down VDDQ Current	$I_{SD\_VDDQ}$	ENABLE = 0		150		$\mu\text{A}$
Shut-Down AVIN Current	$I_{SD\_AVIN}$	ENABLE = 0		900		$\mu\text{A}$
VREF Pin Current				20nA		
Output Voltage Accuracy – Initial	$\Delta V_{OUT}$	$V_{OUT} = 1/2 VDDQ$ (e.g. @ VDDQ = 1.500V), 0.1% VREF and VOUT resistor dividers)	0.740	0.750	0.760	V
VFB Pin Voltage	$V_{VFB}$	$2.9\text{V} \leq AVIN \leq 3.7\text{V}$ , VREF=600mV, $0\text{A} \leq I_{LOAD} \leq 5\text{A}$	591	600	609	mV
VFB Pin Input Leakage Current	$I_{VFB}$	VFB pin input leakage current		20		nA
Continuous Output Sourcing Current	$I_{OUT\_SRC}$		0		5	A
Continuous Output Sinking Current	$I_{OUT\_SNK}$		0		5	A
Over Current Trip Level	$I_{OCPH}$	Sourcing. VDDQ = 1.35V		11		A
Switching Frequency	$F_{SW}$	$R_{FQADJ} = 3.57\text{k}\Omega$		1.5		MHz
Frequency Adjust Resistor	$R_{FQADJ}$			3.57		k $\Omega$
Pre-Bias Level	$V_{PB}$	Allowable pre-bias as a fraction of programmed output voltage for monotonic start up	20		85	%
Non-Monotonicity	$V_{PB\_NM}$	Allowable non-monotonicity under pre-bias start up		50		mV
$V_{OUT}$ Range for P <sub>OK</sub> = High		Range of output voltage as a fraction of programmed value when P <sub>OK</sub> is asserted	92		110	%
P <sub>OK</sub> Deglitch Delay		Falling edge deglitch delay after output crossing 90% level		64		Clock cycles
V <sub>POK</sub> Output Low Level		With 4mA current sink into P <sub>OK</sub> pin		0.6		V
V <sub>POK</sub> Output High Level		When pulled up to AVIN (3.3V) with R <sub>POK</sub> = 100k; $V_{POK} = AVIN * (196\text{k}/(R_{POK} + 196\text{k}))$ ;		2.2		V
P <sub>OK</sub> Current Sink Capability		$2.9\text{V} \leq AVIN \leq 3.7\text{V}$		4		mA

PARAMETER	SYMBOL	TEST CONDITIONS	MIN	TYP	MAX	UNITS
Enable Threshold	$V_{ENABLE}$	$2.9V \leq AVIN \leq 3.7 V$ ; Min voltage to ensure the converter is enabled	1.3			V
Disable Threshold	$V_{DISABLE}$	Max voltage to ensure the converter is disabled			0.8	V
Enable Pin Current	$I_{EN}$	$AVIN = 3.6V$		50		$\mu A$
Binary Pin Logic Low Threshold	$V_{B-LOW}$	VDDQOK, EN_PB			0.8	V
Binary Pin Logic High Threshold	$V_{B-HIGH}$	VDDQOK, EN_PB	1.8			V

Typical Performance Curves

EFFICIENCY vs. OUTPUT CURRENT

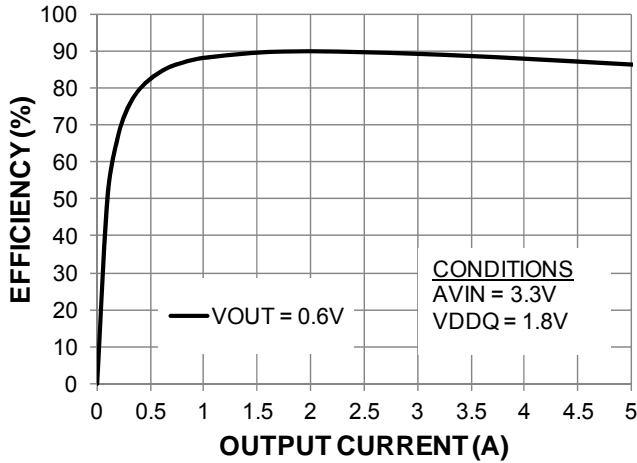

EFFICIENCY vs. OUTPUT CURRENT

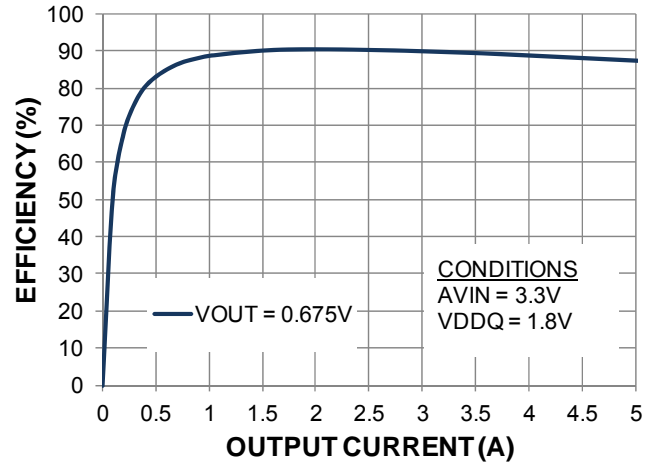

EFFICIENCY vs. OUTPUT CURRENT

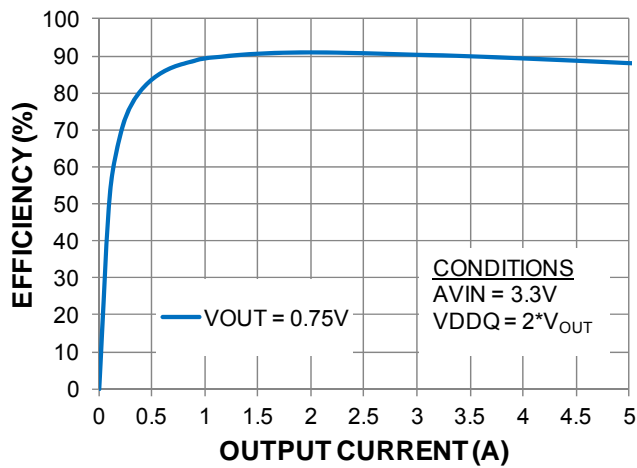

EFFICIENCY vs. OUTPUT CURRENT

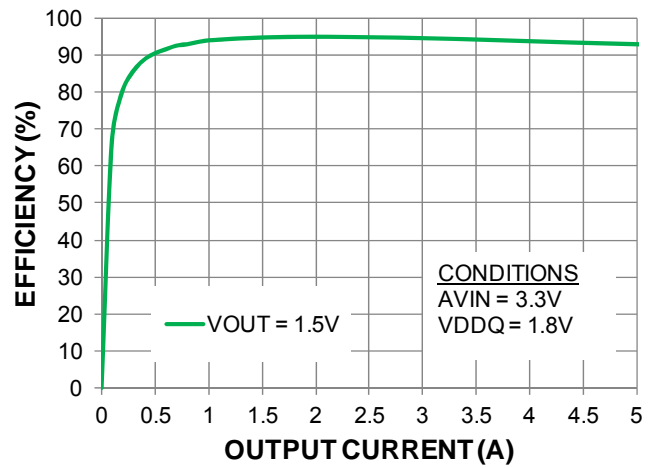

EFFICIENCY vs. OUTPUT CURRENT

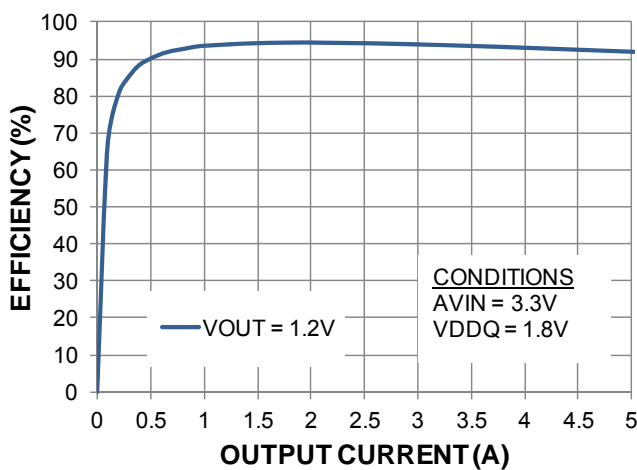

VOUT vs. IOU

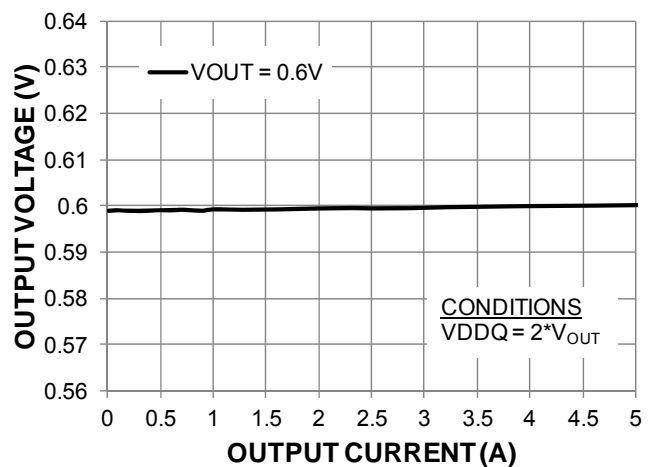

Typical Performance Curves (Continued)

VOUT vs. IOU

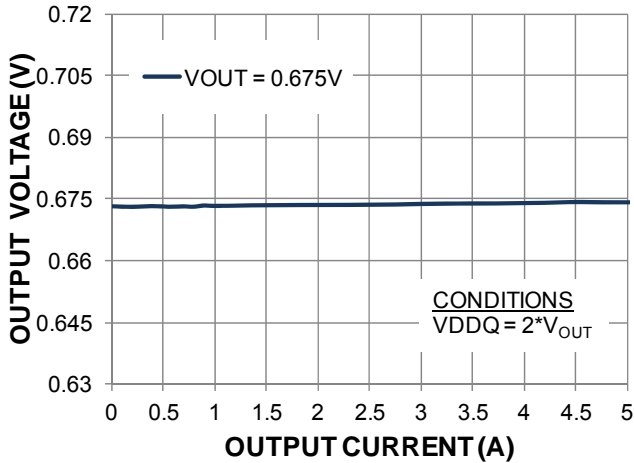

VOUT vs. IOU

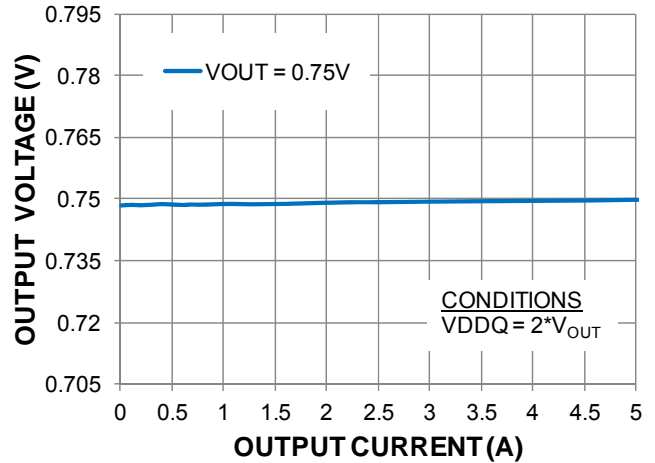

VOUT vs. IOU

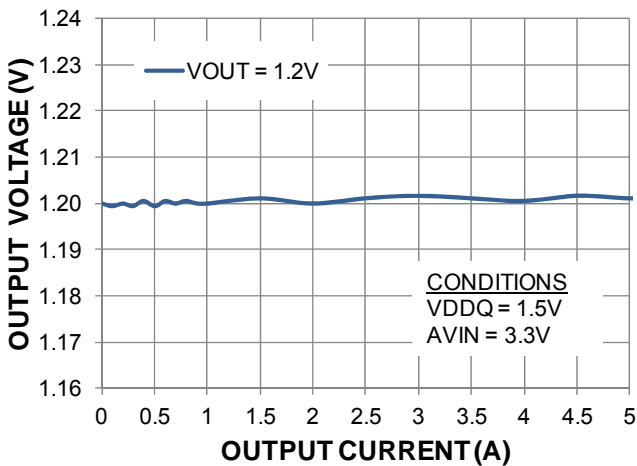

VOUT vs. IOU

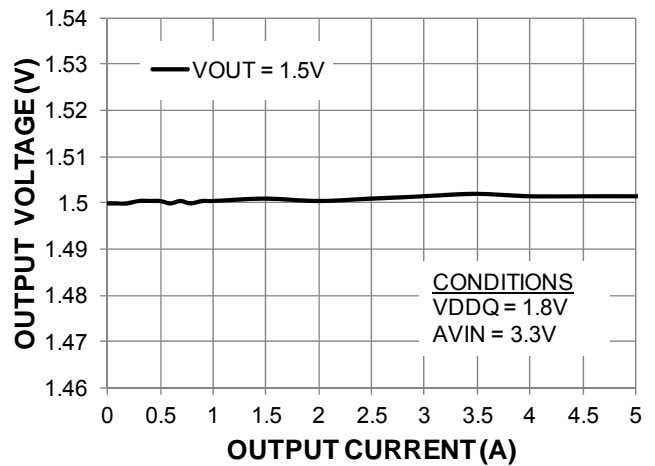

VOUT vs. TEMPERATURE

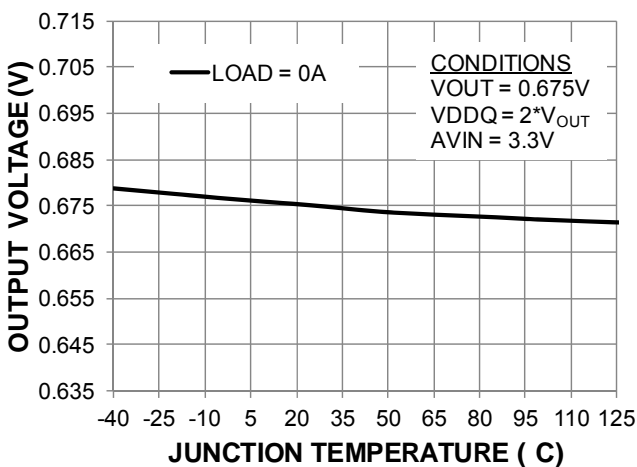

VOUT vs. TEMPERATURE

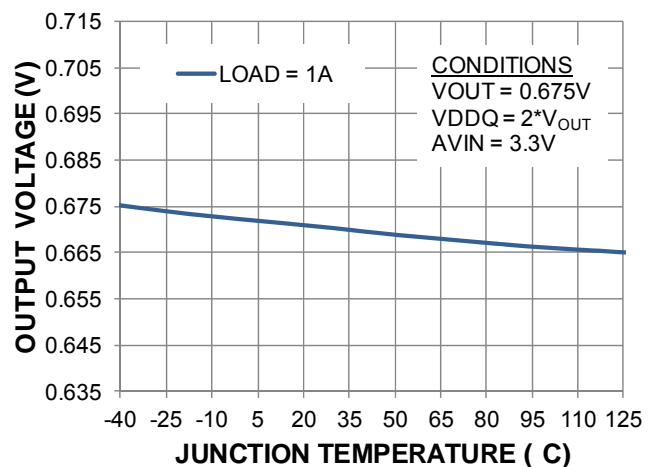

# Typical Performance Characteristics

### Output Ripple at 20MHz Bandwidth

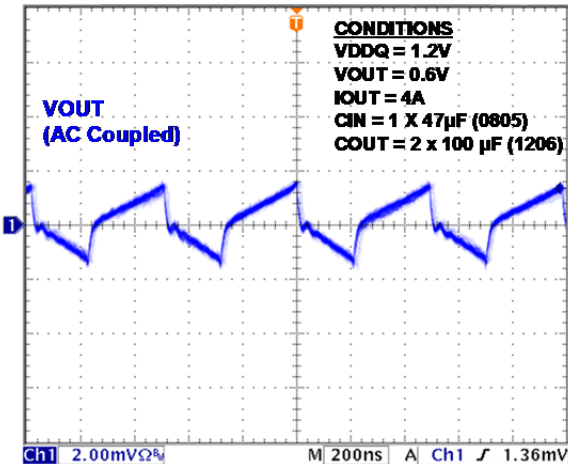

### Output Ripple at Full Bandwidth

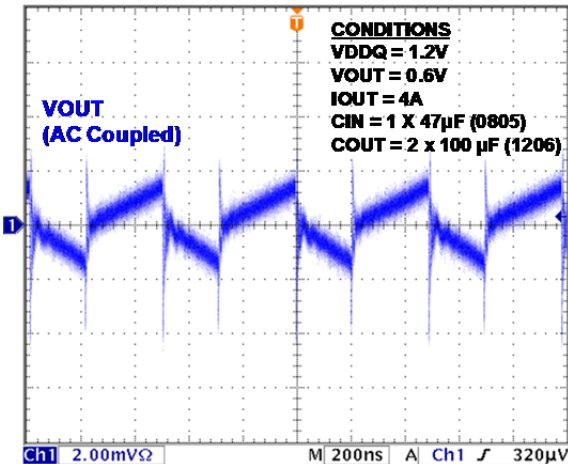

### Output Ripple at 20MHz Bandwidth

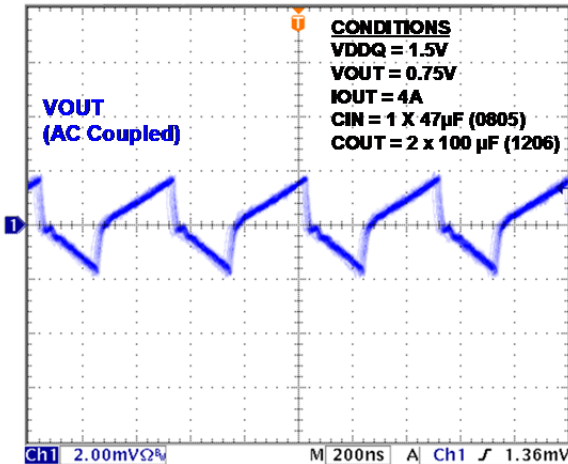

### Output Ripple at Full Bandwidth

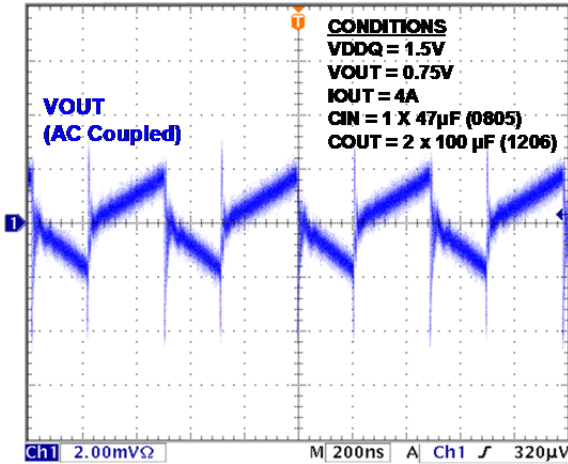

### Startup with Enable

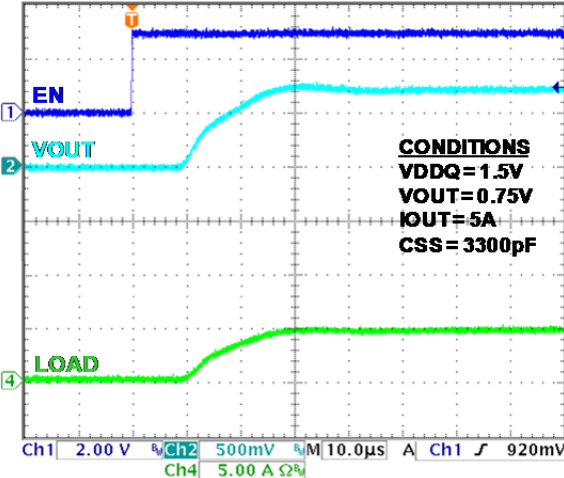

### Shutdown with Enable

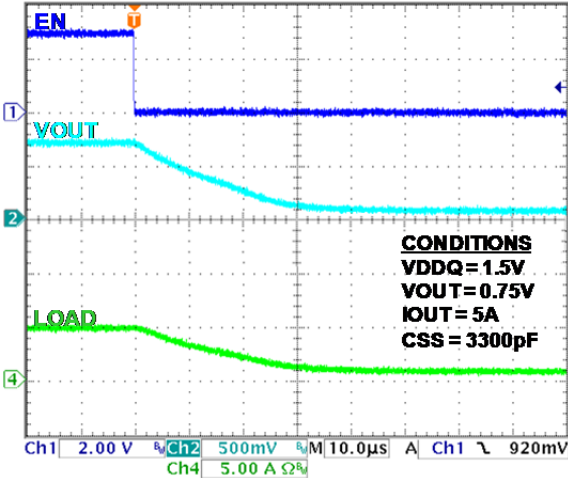

Typical Performance Characteristics (Continued)

Startup with VDDQ

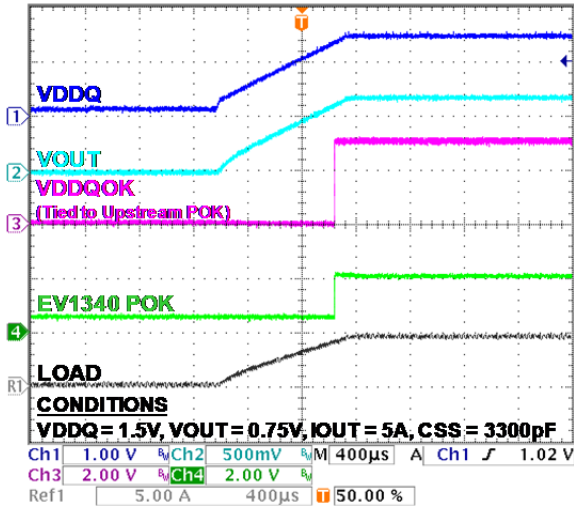

Shutdown with VDDQ

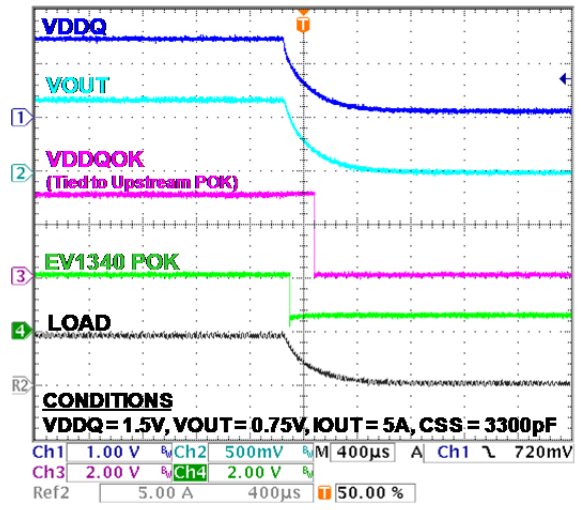

Load Transient from 0 to 4A

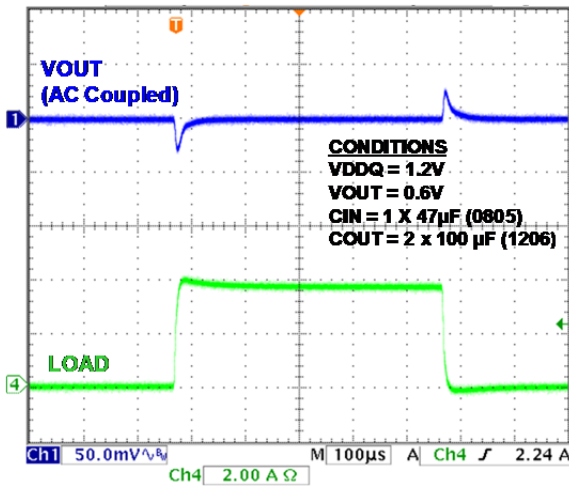

Load Transient from 0 to 4A

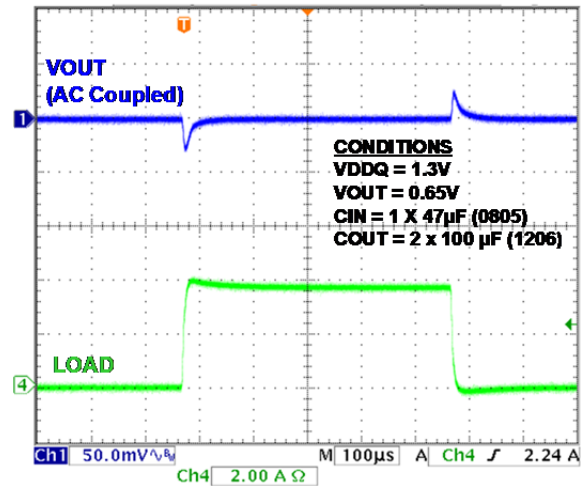

Load Transient from 0 to 4A

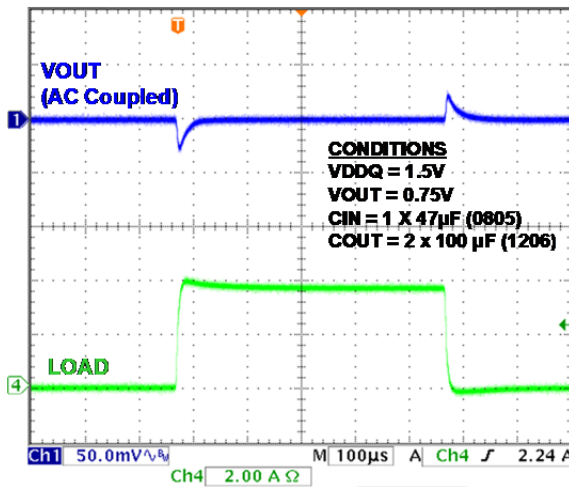

Load Transient from 0 to 4A

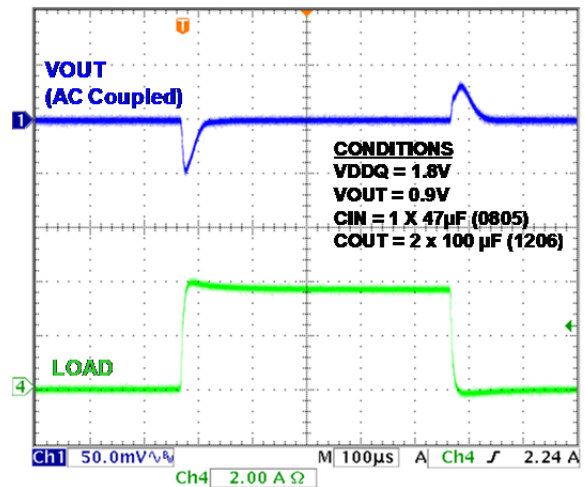

Functional Block Diagram

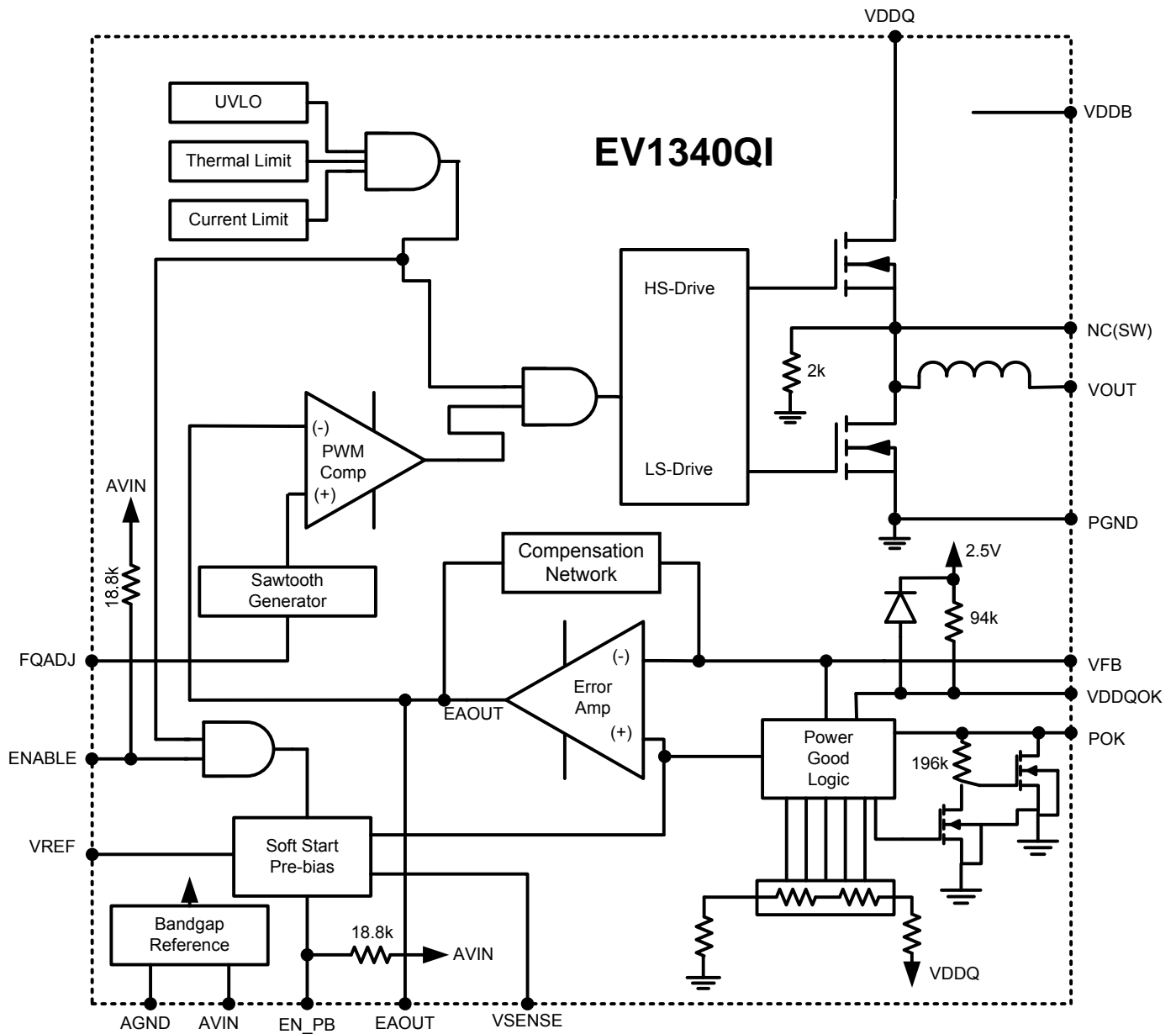

Figure 4: Functional Block Diagram

## Functional Description

### Synchronous Buck Converter

The EV1340 is a synchronous, programmable buck power supply with integrated power MOSFET switches and integrated inductor. The switching supply uses voltage mode control and a low noise PWM topology. Two power sources are required to operate this device; a power supply for the controller (AVIN) with a nominal input voltage range of 2.9-3.7V. The second supply (VDDQ) is the supply that is tracked - the recommended operating range is 1.0 to 1.8V. With the right choice of input and output dividers, the output voltage of the EV1340 will produce an output voltage which tracks to  $\frac{1}{2}$  VDDQ. The EV1340 can continuously source or sink currents up to 5A. The 1.5MHz nominal switching frequency enables small-size input and output capacitors.

### Enable Operation

The ENABLE pin provides a means to enable normal operation or to shut down the device. When the ENABLE pin is asserted (high) the device will undergo a normal soft-start. A logic low on this pin will power the device down.

### Soft-Start and Soft-Shutdown

The EV1340 can operate with the controller power supply (AVIN) ON, ENABLE High, and VDDQ ramped up and down at a relatively slow rate ( $\sim 1\text{V/ms}$ ). It is also expected that VDDQ may be dynamically scaled within a small voltage range. If, however, VDDQ should ramp up at a high rate, or if the device is enabled with a stable VDDQ, a capacitor connected between VREF and AGND provides the soft-start function to limit in-rush current. The soft-start time constant is determined by the input voltage divider and the soft-start capacitor. See Figure 5.

### Pre-Bias Start-up

The EV1340 supports start up into a pre-biased load. A proprietary circuit ensures the output voltage ramps up monotonically from

the pre-bias value to the programmed output voltage. Monotonic start-up is guaranteed for pre-bias voltages in the range of  $>20\%$  to  $<85\%$  of the programmed output voltage. Outside of this range, the output voltage may not rise monotonically. The Pre-Bias feature is controlled by the EN\_PB pin. For the pre-Bias feature to function properly, VDDQ must be stable, and the device must be turned on and off using the ENABLE pin.

### VDDQOK Operation

The VDDQOK pin can be used to indicate that the VDDQ voltage is in regulation by tying it to an upstream POK signal. The upstream device is assumed to be driving the EV1340QI. VDDQOK is internally pulled up to 2.5V through a 94k resistor and is AND'ed with the POK of the EV1340QI. The VDDQOK's high logic level voltage is clamped at a diode drop above 2.5V. VDDQOK signal must be high in order for the POK of the EV1340QI to be high.

### POK Operation

The internal EV1340 POK is AND'ed with the VDDQOK input. POK is meant to be used with VDDQOK in a tracking application with VDDQ ramping. The VDDQOK input is assumed to be driven by the upstream VDDQ regulator's POK output. Normally the VDDQOK input indicates that VDDQ has settled to the required level. If VDDQ is dynamically switched, VDDQOK is expected to mask the EV1340 POK during the voltage transition. POK is de-asserted low 64 clock cycles ( $\sim 43\mu\text{s}$  at 1.5MHz) after the falling VOUT voltage crosses 45% (nominal) of VDDQ. POK is also de-asserted if VOUT exceeds 55% (nominal) of VDDQ. For proper POK thresholds, the input voltage divider must generate VREF nominally set to  $0.4 \cdot \text{VDDQ}$ .

### Over-Current Protection

The current limit function is achieved by sensing the current flowing in the hi-Side FET. When the sensed current exceeds the current limit, the PWM pulse is terminated for the rest

of the switching cycle. If the over-current condition lasts only a few switching cycles, normal PWM operation is resumed. If the over-current condition persists, the circuit will continue to protect the load by entering a hiccup mode. In the hiccup mode, the output is disabled for approximately 20ms and then it goes through a soft-start. The output will no longer track the input voltage briefly as a result of the fault condition. This cycle can continue indefinitely as long as the over current condition persists.

### Thermal Overload Protection

Temperature sensing circuits in the controller will disable operation when the Junction temperature exceeds approximately 150°C. When the junction temperature drops by

approx 20°C, the converter will re-start with a normal soft-start cycle.

### Input Under-Voltage Lock-Out

When the AVIN pin voltage is below a required voltage level ( $V_{UVLOR}$ ) for normal operation, converter switching is inhibited. The lock-out threshold has hysteresis to prevent chatter. When the device is operating normally, the AVIN voltage must fall below the lower threshold ( $V_{UVLOF}$ ) for the device to stop switching.

## Application Information

### Soft-Start Capacitor Selection

A soft-start capacitor is recommended on the EV1340's VREF pin to ground. The soft-start capacitor ( $C_{SS}$ ) serves as a slew rate limiter for fast VDDQ input ramps or for turning the device ON using the ENABLE pin. It is also a noise filter for noise coming from VDDQ. The soft-start time constant is determined by the value of this capacitor and the input divider resistors  $R_C$  and  $R_D$ . See Figure 5. Altera recommends a starting value of 3300pF for the soft-start capacitor on the VREF node.

### Output Voltage Programming and Loop Compensation

The output voltage of EV1340QI is determined by the two voltage dividers as shown in the simplified application diagram below:

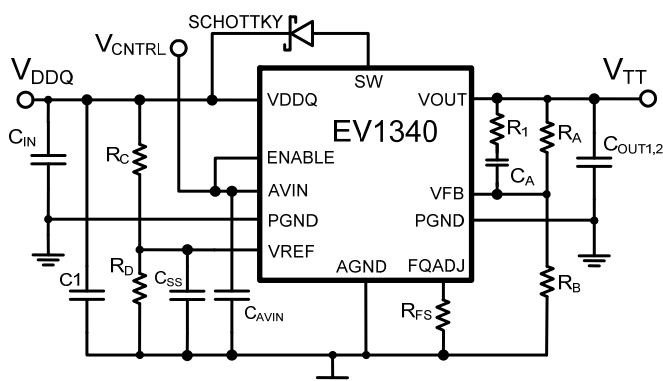

Figure 5: Typical Application Schematic

The input voltage divider consisting of  $R_C$  and  $R_D$  should be selected to make  $V_{REF} = 0.4 * V_{DDQ}$  for proper POK operation. Altera recommends  $R_C = 15k\Omega$  and  $R_D = 10k\Omega$ . This resistor ratio is essential for proper operation of POK. In steady state,  $V_{REF} = V_{FB}$ , and  $V_{OUT} = 0.5 * V_{DDQ}$  given the recommended values for  $R_A - R_D$ .

Although the EV1340 integrates most of the compensation network, a phase lead capacitor and a resistor are required in parallel with the upper resistor  $R_A$  of the external feedback network. See Figure 6 for all the component values in the compensation circuit, which has been optimized for use with 2X100 $\mu$ F, 1206, X5R or X7R ceramic output capacitors.

In rare cases, modifications to the compensation might be required. The EV1340 compensation can be modified for specific applications. For more information, contact Power Applications support.

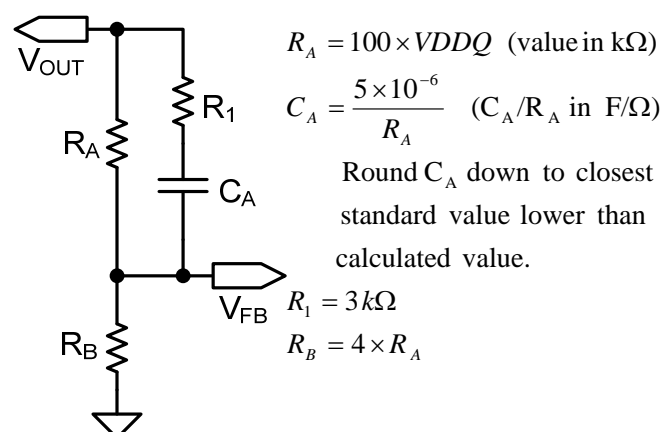

Figure 6: External Feedback and Compensation Network

### Input Capacitor Selection

The EV1340 requires a minimum of 47 $\mu$ F of input capacitance for VDDQ. Additional capacitors ( $C_{AVIN}$  and  $C_1$ ) of 10 $\mu$ F is recommended for AVIN and the resistor divider network of VREF ( $R_C$ ,  $R_D$ ). Low ESR ceramic capacitors are required with X5R or X7R dielectric formulation. Y5V or equivalent dielectric formulations must not be used because these dielectrics lose capacitance with frequency, temperature and bias voltage.

In some applications, lower value ceramic capacitors maybe needed in parallel with the larger capacitors in order to provide high frequency decoupling.

The table below shows some typical recommended input capacitors for the EV1340. Other capacitors with similar characteristics may also be used in the input circuit.

### Typical Recommended Input Capacitors

Description	MFG	P/N
47 $\mu$ F, 10V, X5R, 1206	Taiyo Yuden	LMK316BJ476ML-T
47 $\mu$ F, 4V, X5R, 0805	Murata	GRM21BR60G476M

## Output Capacitor Selection

The EV1340 has been optimized for use with 200 $\mu$ F of output capacitance. Low ESR ceramic capacitors are required with X5R or X7R dielectric formulation. Y5V or equivalent dielectric formulations must not be used as these lose capacitance with frequency, temperature and bias voltage. The capacitors shown in the table below are some typical output capacitors. Other capacitors with similar characteristics may also be used.

## Typical Recommended Output Capacitors

Description	MFG	P/N
47 $\mu$ F, 10V, X5R, 1206	Taiyo Yuden	LMK316BJ476ML-T
47 $\mu$ F, 6.3V, X5R, 1206	Taiyo Yuden Murata	JMK316BJ476ML-T GRM31CR60J476ME19L
100 $\mu$ F, 6.3V, X5R, 1206	Murata	GRM31CR60J107M

Output ripple voltage is primarily determined by the aggregate output capacitor impedance. At the 1.5MHz switching frequency output impedance, denoted as Z, is comprised mainly of effective series resistance, ESR, and effective series inductance, ESL:

$$Z = \text{ESR} + \text{ESL}$$

Placing multiple capacitors in parallel reduces the impedance and hence will result in lower ripple voltage.

$$\frac{1}{Z_{\text{Total}}} = \frac{1}{Z_1} + \frac{1}{Z_2} + \dots + \frac{1}{Z_n}$$

## Typical Ripple Voltages

Output Capacitor Configuration	Typical Output Ripple (mVp-p) VDDQ = 1.5V, VOUT = 0.75V
2 x 100 $\mu$ F	<10mV

## Schottky Diode Selection

The EV1340 requires a Schottky diode from the SW pin to the VDDQ pin. The anode should be facing the SW pin and the cathode facing the VDDQ pin. Altera has characterized the ST Microelectronics TMBYV10-40FILM diode with the EV1340. Contact Power Applications support for alternate options for this diode.

## Low V<sub>IN</sub> Applications

The EV1340 is an excellent solution for low V<sub>IN</sub> applications where highest efficiency is very critical. Reference the low V<sub>IN</sub> efficiency chart in the Typical Performance Characteristics section for estimated efficiencies at several use cases. In these applications, a precision voltage reference is required for the VREF input of the EV1340. Figure 7 shows a schematic for a typical low V<sub>IN</sub> application.

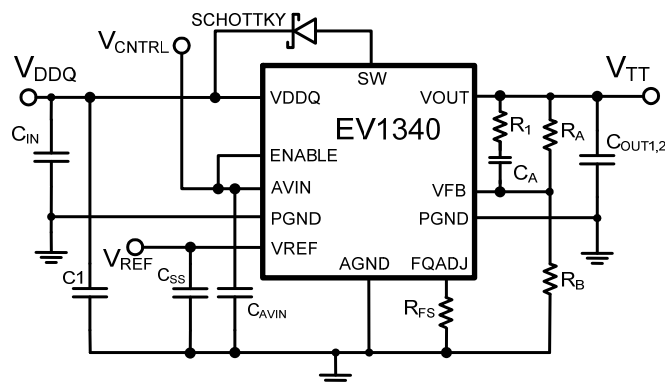

Figure 7: Typical Low V<sub>IN</sub> Application Schematic

## Power-Up Sequencing

During power up, neither ENABLE nor VDDQ should be asserted before AVIN. There are two common acceptable turn-on/off sequences for the device. ENABLE can be tied to AVIN and come up with it, and VDDQ can be ramped up and down as needed. Alternatively, VDDQ can be brought high after AVIN is asserted, and the device can be turned on and off by toggling the ENABLE pin.

## Layout Recommendations

Figure 8 and Figure 9 shows critical components along with top and bottom traces of a recommended minimum footprint of the EV1340QI layout with ENABLE tied to  $V_{IN}$ . Alternate ENABLE configurations and other small signal pins need to be connected and routed according to specific customer application. Please see the Gerber files at [www.altera.com/enpirion](http://www.altera.com/enpirion) for exact dimensions and other layers. Please refer to Figures 8 and 9 while reading the layout recommendations in this section.

**Recommendation 1:** Input and output filter capacitors should be placed on the same side of the PCB, and as close to the EV1340QI package as possible. They should be connected to the device with very short and wide traces. Do not use thermal reliefs or spokes when connecting the capacitor pads to the respective nodes. The +V and GND traces between the capacitors and the EV1340QI should be as close to each other as possible so that the gap between the two nodes is minimized, even under the capacitors.

**Recommendation 2:** There are a total of seven PGND pins dedicated to the input and output circuits. The input and output ground currents should be separated with a slit until they reach the seven PGND pins to help minimize noise coupling between the converter input and output switching loops.

**Recommendation 3:** The system ground plane should be the first layer immediately below the surface layer. This ground plane should be continuous and un-interrupted below the converter and the input/output capacitors. Please see the Gerber files at [www.altera.com/enpirion](http://www.altera.com/enpirion).

**Recommendation 4:** The large thermal pad underneath the component must be connected to the system ground plane through as many vias as possible.

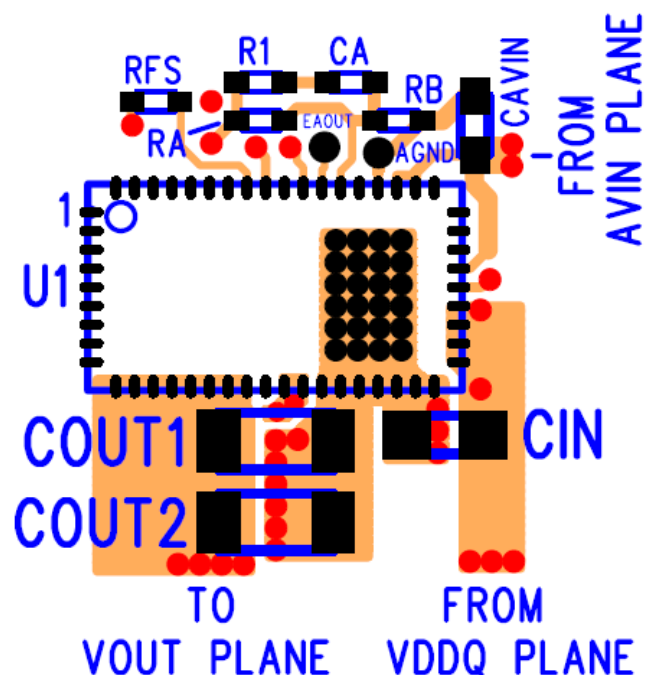

Figure 8: Top PCB Layer with Critical Components and Copper for Minimum Footprint (Top View)

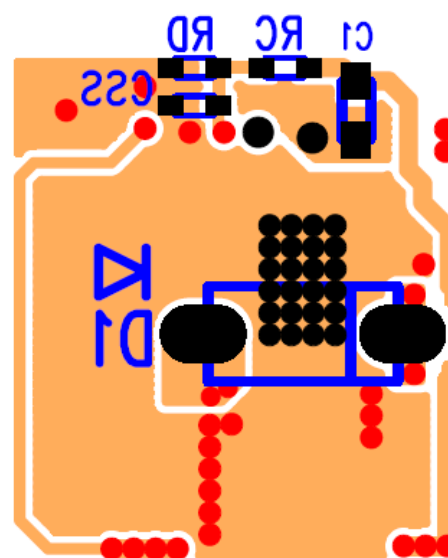

Figure 9: Bottom PCB Layer with Critical Components and Copper for Minimum Footprint (Top View)

The drill diameter of the vias should be 0.33mm, and the vias must have at least 1 oz. copper plating on the inside wall, making the finished hole size around 0.20-0.26mm. Do not use thermal reliefs or spokes to connect the vias to the ground plane. This connection provides the path for heat dissipation from the converter. Please see Figures 8, 9, 10, and 11.

**Recommendation 5:** Multiple small vias (the same size as the thermal vias discussed in recommendation 4) should be used to connect ground terminal of the input capacitor and output capacitors to the system ground plane. It is preferred to put these vias under the capacitors along the edge of the GND copper closest to the +V copper. Please see Figure 8 and Figure 9. These vias connect the input/output filter capacitors to the GND plane and help reduce parasitic inductances in the input and output current loops. If the vias cannot be placed under  $C_{IN}$  and  $C_{OUT}$ , then put them just outside the capacitors along the GND slit separating the two components. Do not use thermal reliefs or spokes to connect these vias to the ground plane.

**Recommendation 6:** AVIN1 and AVIN2 are the power supplies for the internal small-signal control circuits. AVIN1 and AVIN2 should be powered by an external supply. In Figure 8, the filter capacitor  $C_{AVIN}$  is connected closely from the AVIN1 and AVIN2 pins to AGND for proper filtering of the control circuit.

**Recommendation 7:** The layer 1 metal under the device must not be more than shown in Figure 8. See the section regarding exposed metal on bottom of package. As with any switch-mode DC/DC converter, try not to run sensitive signal or control lines underneath the converter package on other layers.

**Recommendation 8:** The  $V_{OUT}$  sense trace to  $R_A$  should come just after the last output filter capacitor  $C_{OUT2}$ . Keep the sense trace as

short as possible in order to avoid noise coupling into the control loop.

**Recommendation 9:** Keep  $R_A$ ,  $C_A$ ,  $R_1$  and  $R_B$  close to the VFB pin (see Figure 8). The VFB pin is a high-impedance, sensitive node. Keep the trace to this pin as short as possible. Whenever possible, connect  $R_B$  directly to the AGND pin instead of going through the GND plane.

**Recommendation 10:** Connect AGND to the ground plane through a single via as close to the AGND pin as possible. This establishes the connection between AGND and PGND.

**Recommendation 11:** The VREF pin sets the reference voltage for  $V_{OUT}$  and should be as clean as possible. The connection from VDDQ to VREF should begin from the  $C_{IN}$  input capacitor to VREF through a resistor voltage divider ( $R_C$ ,  $R_D$ ). The soft-start capacitor  $C_{SS}$ ,  $R_C$ , and  $R_D$  form a low-pass RC filter for the VREF pin. A bypass capacitor  $C_1$  should be placed close to the  $R_C$  resistor for additional filtering. The long trace from VDDQ to  $C_1$  forms a low-pass LC filter with  $C_1$  and helps further reduce noise coupling to VREF.

**Recommendation 12:** The Schottky diode  $D_1$  should be connected with anode to SW and cathode to VDDQ with very low inductance traces. Place  $D_1$  directly under the device as shown in Figure 9. Vias near SW and VDDQ connect these pins to the  $D_1$  terminals. The recommended diode for this layout is ST Microelectronics TMBYV10-40FILM. Contact Power Applications support for alternate options for this diode.

**Recommendation 13:** Altera provides schematic and layout reviews for all customer designs. It is highly recommended for all customers to take advantage of this service. Please send pdf schematic files and Gerber layout files of the power section to your local sales contact or to Power Applications support.

## Design Considerations for Lead-Frame Based Modules

### Exposed Metal on Bottom of Package

Package lead frames offer advantages in thermal performance, in reduced electrical lead resistance, and in overall foot print. They do, however, require some special considerations.

In the assembly process, lead-frame construction requires-for mechanical support-that some of the lead-frame cantilevers be exposed at the point where wire-bonds or internal passives are attached. Because of this

lead frame requirement, several small pads are exposed on the bottom of the package. Only the large thermal pad and the perimeter pads should be mechanically or electrically connected to the PC board. The PCB top layer under the EV1340 should be clear of any metal except for the large thermal pad. The hatched area in Figure 10 represents the area that should be clear of all metal (traces, vias, or planes) on the top layer of the PCB.

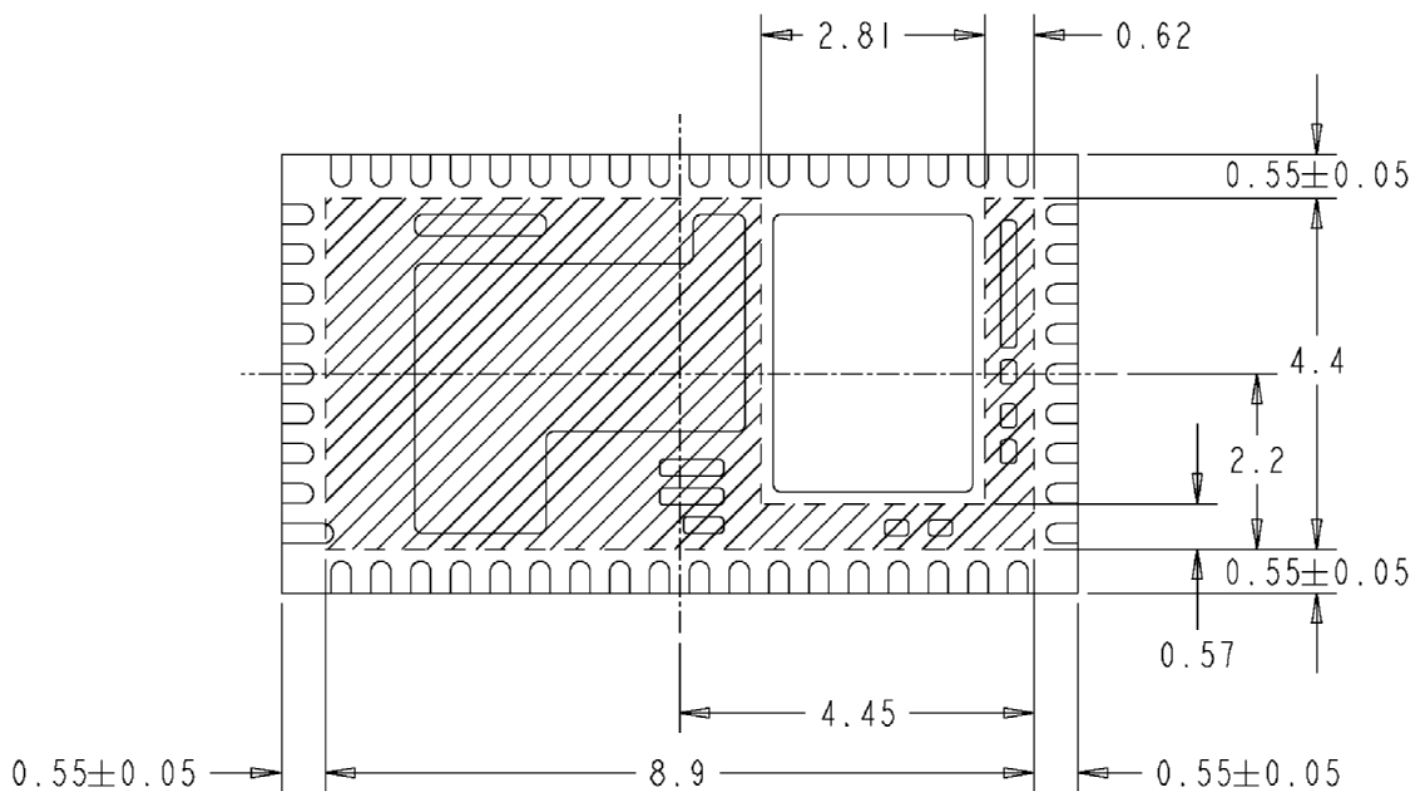

**Figure 10: Lead-Frame Exposed Metal (Bottom View).** The dimensioned hatched area highlights exposed metal below the device which should not be soldered down. There should not be any metal (traces, vias, or planes) on the top layer of the PCB below the hatched area.



## Package and Mechanical

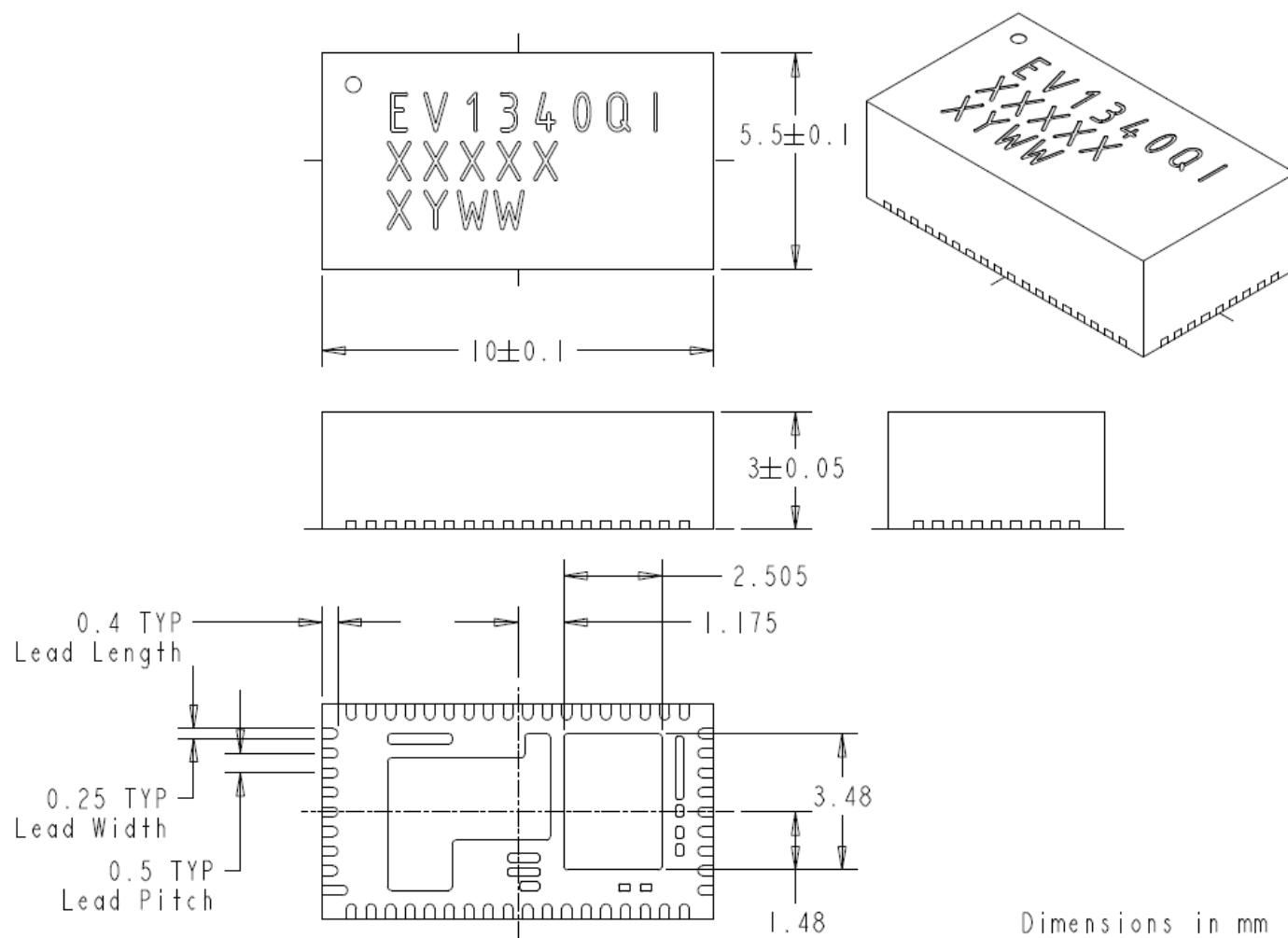

**Figure 12: EV1340 Package Dimensions**

## Contact Information

Altera Corporation  
 101 Innovation Drive  
 San Jose, CA 95134  
 Phone: 408-544-7000  
[www.altera.com/](http://www.altera.com/)

© 2013 Altera Corporation—Confidential. All rights reserved. ALTERA, ARRIA, CYCLONE, ENPIRION, HARDCOPY, MAX, MEGACORE, NIOS, QUARTUS and STRATIX words and logos are trademarks of Altera Corporation and registered in the U.S. Patent and Trademark Office and in other countries. All other words and logos identified as trademarks or service marks are the property of their respective holders as described at [www.altera.com/common/legal.html](http://www.altera.com/common/legal.html). Altera warrants performance of its semiconductor products to current specifications in accordance with Altera's standard warranty, but reserves the right to make changes to any products and services at any time without notice. Altera assumes no responsibility or liability arising out of the application or use of any information, product, or service described herein except as expressly agreed to in writing by Altera. Altera customers are advised to obtain the latest version of device specifications before relying on any published information and before placing orders for products or services.

## Looking for pricing, stock, or lifecycle information?

Click below to explore more details on WIN SOURCE:

 [View EV1340QI on WIN SOURCE](#)

 [Intel Information](#)

## Optimize Your Supply Chain with WIN SOURCE Solutions

-  Global Sourcing Solution
-  Obsolete Management
-  Cost Control Management
-  Shortage Management
-  Alternative Solution
-  Excess Inventory Management