



**THE DATASHEET OF
ANCW12G45SAA117RD3**





Specification of CHIP DIELECTRIC ANTENNA
 SPEC No. :NAN68-PC0332F
 Part Number :ANCW12G45SAA117TT1/RD3

Written by S. Ito
 Checked by Y. Kushihi
 Date 19/Mar./2003

***: TT1: Bulk package / RD3: 3000pcs/reel

A>: Rev. by J.K on 5th/Dec/'03, B>: Rev. by R.I. on 8/Sep./04, C>: Rev. by R.I. on 30/Nov./04, D>: Rev. by R.I. on 1/Dec./04
 E>: Rev. by R.I. on 24/Dec./04, F>: Rev. by E.M. on 19/Jan./05

1. Electrical Characteristics

A>

Operation Temp	-40 to +85 degree C
Polarization	Linear
Frequency (Fo)	2450MHz.
Band Width (BW)	F0 +/- 50MHz.
V.S.W.R at BW	2.5 max.
Impedance	50 Ω

Note 1: This electrical characteristics are influenced by the land pattern, PCB size, case and so on.

Note 2: This electrical characteristics are guaranteed with our standard measurement conditon which is used our standard land pattern and PCB in Section 2.2 and 2.3.

2. Mechanical

2.1.Dimensions

A>B>F>

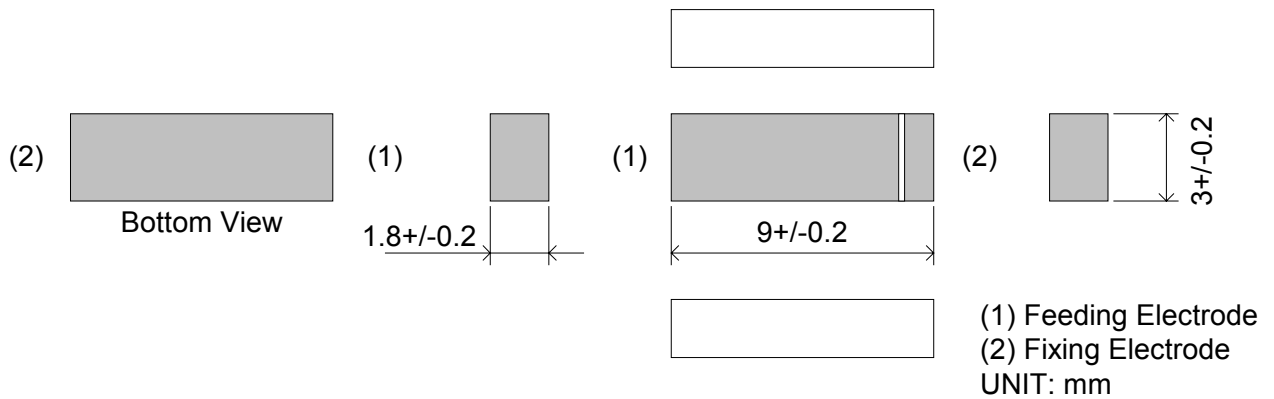

A>C> Matching Circuit

Application	2.4GHz W-LAN / BT	PHS
Matching Circuit		
Frequency (Fo)	2425MHz.	1913MHz
Band Width (BW)	225MHz (VSWR < 3)	100MHz (VSWR < 3)

Note 1: This electrical characteristics are guaranteed with our standard measurement conditon which is used our standard land pattern and PCB in Section 2.2 and 2.3.

Preliminary Specification of CHIP DIELECTRIC ANTENNA
 Preliminary SPEC No. :NAN68-PC0332F
 Part Number :ANCW12G45SAA117TT1/RD3

Written by S. Ito
 Checked by Y. Kushihi
 Date 19/Mar./2003

***: TT1: Bulk package / RD3: 3000pcs/reel

A>: Rev. by J.K on 5th/Dec/'03, B>: Rev. by R.I. on 8/Sep./04, C>: Rev. by R.I. on 30/Nov./04, D>: Rev. by R.I. on 1/Dec./04
 E>: Rev. by R.I. on 24/Dec./04, F>: Rev. by E.M. on 19/Jan./05

2.2. Standard lands pattern and resist pattern
 A>

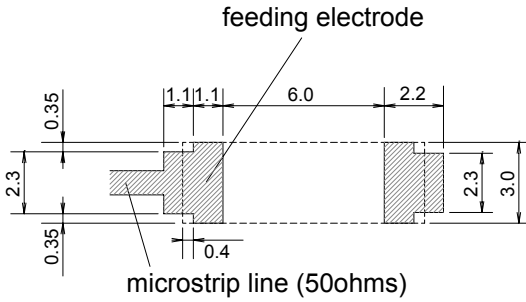

recommended land pattern of PCB

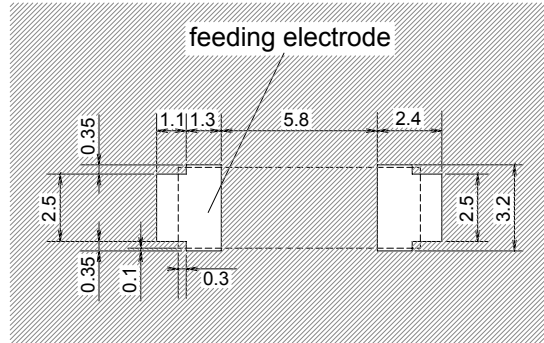

recommended solder-resist pattern

DIMENSIONS : mm
 TOLERANCE : +/-0.05mm

2.3. Standard PCB
 A>F>

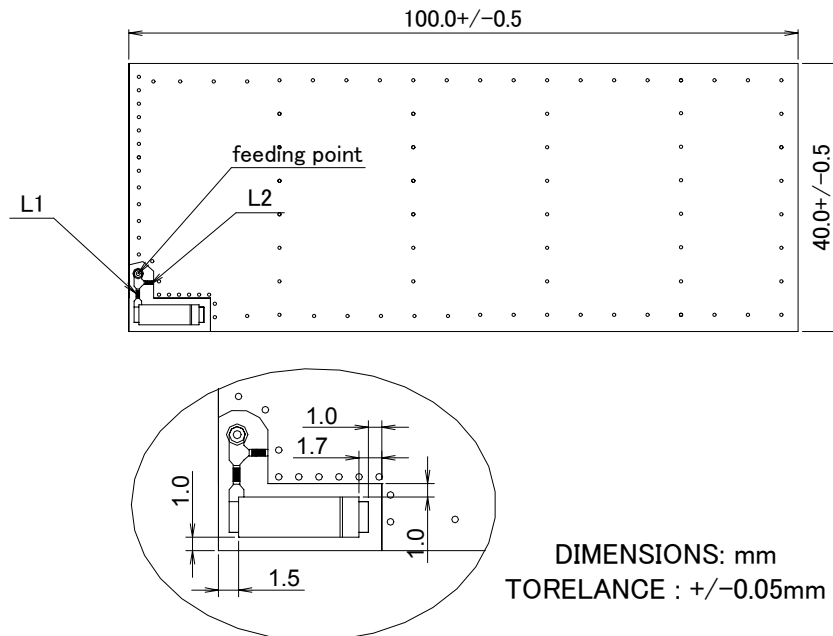

DIMENSIONS: mm
 TORELANCE : +/-0.05mm

Substrate : FR-4 (Both Printed)
 Thickness : 1.0mm (Thickness of copper isb 0.035mm)

Looking for pricing, stock, or lifecycle information?

Click below to explore more details on WIN SOURCE:

- ⊖ [View ANCW12G45SAA117RD3 on WIN SOURCE](#)
- ⊖ [Murata Electronics North America Information](#)

Optimize Your Supply Chain with WIN SOURCE Solutions

- ✓ Global Sourcing Solution
- ✓ Obsolete Management
- ✓ Cost Control Management
- ✓ Shortage Management
- ✓ Alternative Solution
- ✓ Excess Inventory Management