

Low On-Resistance, 5V Wide-Bandwidth 5-port, 2:1 Mux/DeMux VideoSwitch

Features

- High-performance, low-cost solution to switch between video sources
- Wide bandwidth: 550 MHz
- Low On-Resistance: 5Ω
- Low crosstalk at 10 MHz: -90dB
- Ultra-low quiescent power ($0.1\mu\text{A}$ typical)
- Single supply operation: $+5.0\text{V}$
- Fast switching: 10ns
- Packaging (Pb-free & Green available):
– 24-pin 150-mil wide plastic QSOP (Q)

Applications

- Projection TV and LCD TV
- Video consumer applications
- Analog video signal processing

Description

Pericom Semiconductor's PI5V512 is a true bidirectional 5-Port 2:1 multiplexer/demultiplexer with Hi-Z outputs that is recommended for both RGB and composite video switching applications. With the additional 2 ports, vertical and horizontal synchronous signals can be switched in addition to switching the RGB and composite signals between different components, such as DVD, VCR, PCs and etc. The video switch can be driven from a current output RAMDAC or voltage output composite video source.

Low On-Resistance, Low Crosstalk, Low OFF Isolation and wide bandwidth features make it ideal for video and other applications. The device also has exceptional high current capability which is far greater than most analog switches offered today. A single 5V supply is all that is required for operation. The switch is bidirectional and offers little or no attenuation of the high-speed signals at the outputs. The PI5V512 offers a high-performance (550 MHz), low-cost solution to switch between video sources.

Block Diagram

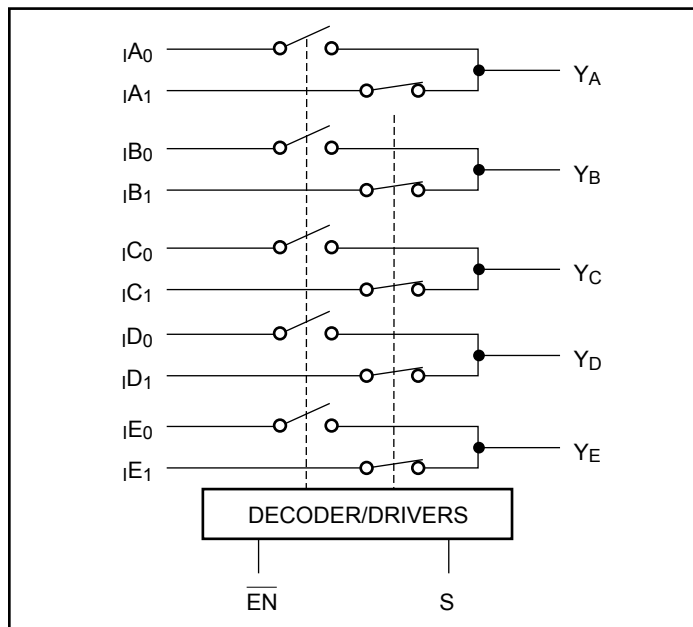

Pin Configuration

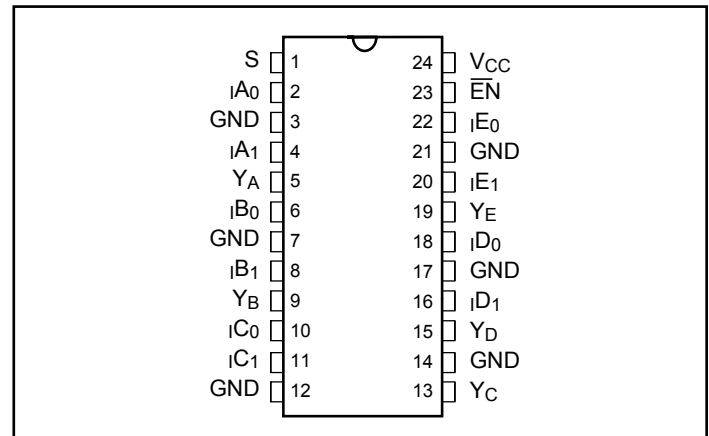

Truth Table

$\overline{\text{EN}}$	S	ON Switch
0	0	$\text{IA}_0, \text{IB}_0, \text{IC}_0, \text{ID}_0, \text{IE}_0$
0	1	$\text{IA}_1, \text{IB}_1, \text{IC}_1, \text{ID}_1, \text{IE}_1$
1	X	Disabled

Maximum Ratings

(Above which the useful life may be impaired. For user guidelines, not tested.)

Storage Temperature	-65°C to +150°C
Ambient Temperature with Power Applied	-40°C to +85°C
Supply Voltage to Ground Potential (Inputs & V _{CC} Only)...	-0.5V to +7.0V
Supply Voltage to Ground Potential (Outputs & D/O Only)	-0.5V to +7.0V
DC Input Voltage	-0.5V to +7.0V
DC Output Current.....	120mA
Power Dissipation	0.5W

Note:

Stresses greater than those listed under MAXIMUM RATINGS may cause permanent damage to the device. This is a stress rating only and functional operation of the device at these or any other conditions above those indicated in the operational sections of this specification is not implied. Exposure to absolute maximum rating conditions for extended periods may affect reliability.

Pin Description

Pin Name	Description
I _{A0} , I _{B0} , I _{C0} , I _{D0} , I _{EQ} , I _{A1} , I _{B1} , I _{C1} , I _{D1} , I _{E1}	Analog Video I/O
S	Select Input
EN	Enable
Y _A , Y _B , Y _C , D _E , Y _D , E _E	Analog Video I/O
GND	Ground
V _{CC}	Power

DC Electrical Characteristics (Over the Operating Range, T_A = -40°C to +85°C, V_{CC} = 5V ±5%)

Parameters	Description	Test Conditions ⁽¹⁾	Min.	Typ. ⁽²⁾	Max.	Units
V _{ANALOG}	Analog Signal Range		0		2.0	V
V _{IH}	Input HIGH Voltage	Guaranteed Logic HIGH Level	2.0			
V _{IL}	Input LOW Voltage	Guaranteed Logic LOW Level	-0.5		0.8	
I _{IH}	Input HIGH Current	V _{CC} = Max., V _{IN} = V _{CC}			±1	μA
I _{IL}	Input LOW Current	V _{CC} = Max., V _{IN} = GND			±1	
I _O	Analog Output Leakage Current	0 ≤ I _O , I _I or D ≤ V _{CC} , Switch OFF			±1	
V _{IK}	Clamp Diode Voltage	V _{CC} = Min., I _{IN} = -18mA	-0.7	-1.2		V
V _H	Input Hysteresis at Control Pins			150		mV
R _{ON}	Switch On-Resistance ⁽³⁾	V _{CC} = Min., V _{IN} = 1.0V, I _{ON} = 13mA		5	8	Ω
		V _{CC} = Min., V _{IN} = 2.0V, I _{ON} = 26mA		7	12	

Notes:

- For Max. or Min. conditions, use appropriate value specified under Electrical Characteristics for the applicable device type.
- Typical values are at V_{CC} = 5.0V, T_A = 25°C ambient and maximum loading.
- Measured by the voltage drop between I_O, I_I, and D I/O pins at indicated current through the switch. On-Resistance is determined by the lower of the voltages on the I_O, I_I, and D I/O pins.

Dynamic Characteristics (Over the Operating Range, $T_A = -40^\circ\text{C}$ to $+85^\circ\text{C}$, $V_{CC} = 5V \pm 5\%$)

Parameters	Description	Test Conditions	Min.	Typ.	Max.	Unit
t_{ON}	Turn On Time	$R_L = 75\Omega$, $C_L = 20\text{pF}$, See Fig. 1		2.5	5	ns
t_{OFF}	Turn Off Time	$R_L = 75\Omega$, $C_L = 20\text{pF}$, See Fig. 1		1.1	5	
$B_W^{(1)}$	-3 dB Bandwidth	See Fig. 2, $C_L = 0\text{pF}$	100	550		MHz
$X_{TALK}^{(1)}$	Crosstalk	10 MHz, See Fig. 2		-90		dB
$C_{IN}^{(1)}$	Input/Enable Capacitance	$V_{IN} = 0V$, $f = 1\text{ MHz}$			6	pF
$C_{OFF}^{(1)}$	Capacitance, Switch Off	$V_{IN} = 0V$, $f = 1\text{ MHz}$			6	
$C_{ON}^{(1)}$	Capacitance, Switch On	$V_{IN} = 0V$, $f = 1\text{ MHz}$			11	
O_{IRR}	Off Isolation	10 MHz, See Fig 2		-60		dB

Notes:

- This parameter is determined by device characterization but is not production tested.

Power Supply Characteristics

Parameters	Description	Test Conditions ⁽¹⁾		Min.	Typ ⁽²⁾	Max.	Units
I_{CC}	Quiescent Power Supply Current	$V_{CC} = \text{Max.}$	$I_N = \text{GND or } V_{CC}$		0.1	3.0	μA
ΔI_{CC}	Supply Current per Input @ TTL HIGH	$V_{CC} = \text{Max.}$	$I_N = 3.4V^{(3)}$			2.5	mA
I_{CCD}	Supply Current per Input per MHz ⁽⁴⁾	$V_{CC} = \text{Max.}$, S1, S2 and D Pins Open $\overline{EN} = \text{GND}$ Control Input Toggling 50% Duty Cycle				0.25	mA/MHz

Notes:

- For Max. or Min. conditions, use appropriate value specified under Electrical Characteristics for the applicable device.
- Typical values are at $V_{CC} = 5.0V$, $+25^\circ\text{C}$ ambient.
- Per TTL driven input ($V_{IN} = 3.4V$, control inputs only); I0, I1, and Y pins do not contribute to I_{CC} .
- This current applies to the control inputs only and represent the current required to switch internal capacitance at the specified frequency. The I0, I1, and Y I/O pins generate no significant AC or DC currents as they transition. This parameter is not tested, but is guaranteed by design.

Definitions

Symbol	Description
R_{ON}	Resistance between source and drain with switch in the ON state.
I_O	Output leakage current measured at I0, I1, and Y with the switch OFF.
V_{IN}	Digital voltage at the S pin that selects between I0 and I1 analog inputs.
V_{EN}	A voltage that ENABLES the chip.
C_{IN}	Capacitance at the digital inputs.
C_{OFF}	Capacitance at analog I/O (I0, I1, and Y) with switch OFF.
C_{ON}	Capacitance at analog I/O (I0, I1, and Y) with switch ON.
V_{IH}	Minimum input voltage for logic HIGH.
V_{IL}	Minimum input voltage for logic LOW.
I_{IH} (I_{IL})	Input current of the digital input.
t_{ON}	Propagation delay measured between 50% of the digital input to 90% of the analog output when switch is turned ON. The peak analog voltage is 0.714V.
t_{OFF}	Propagation delay measured between 50% of the digital input to 90% of the analog output when switch is turned OFF. The peak analog voltage is 0.714V.
BW	Frequency response of the switch in the ON state measured at 3dB down.
X_{TALK}	Unwanted signal coupled from channel to channel, measured in -dB. $X_{TALK} = 20 \text{ LOG } V_{OUT}/V_{IN}$. This is non-adjacent crosstalk.
O_{IRR}	Off isolation is the resistance (measured in -dB) between the input and output with the switch off (NO).

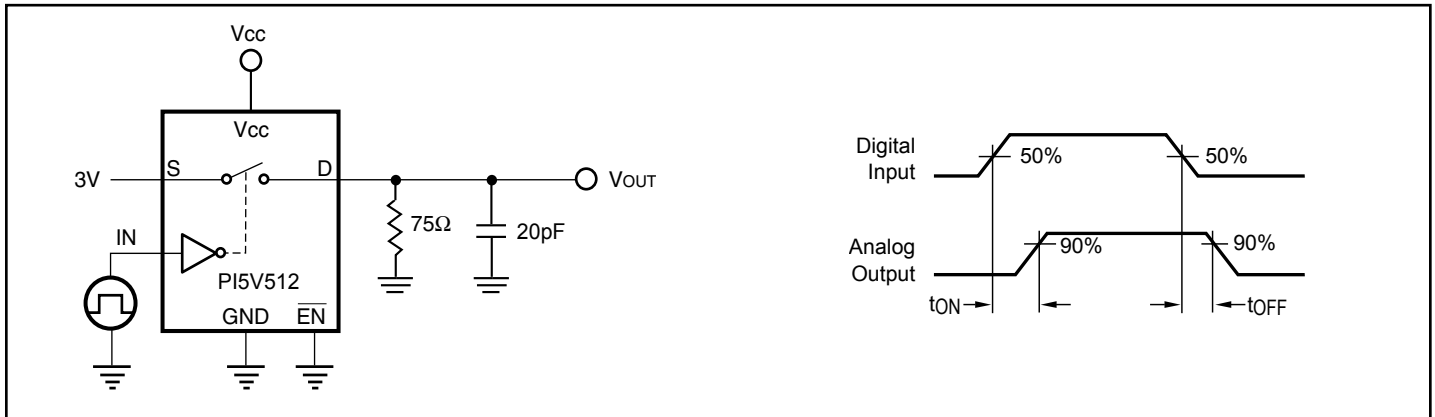

Figure 1. Switching Time

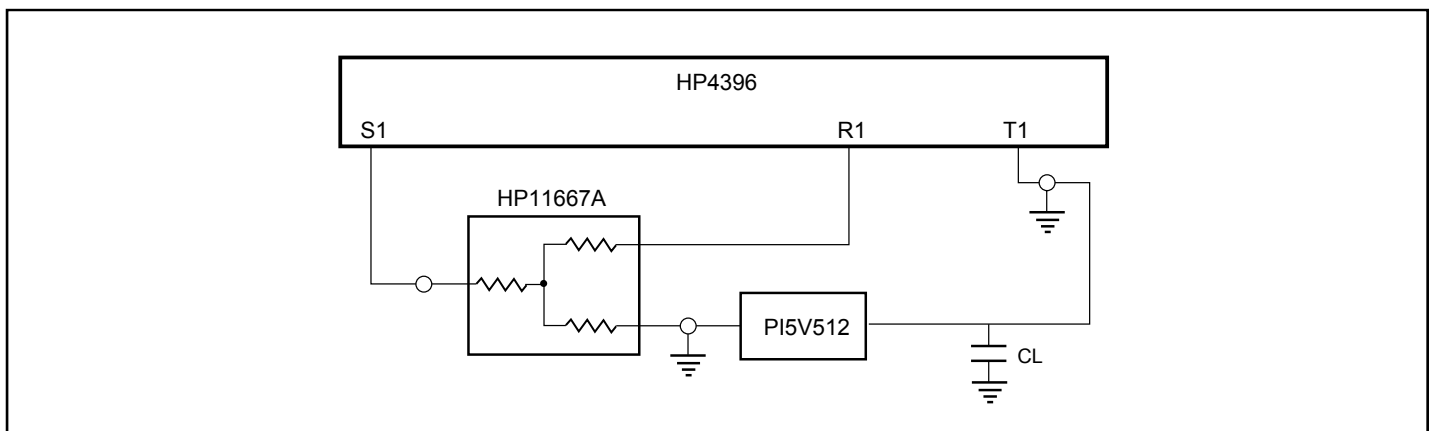

Figure 2. Gain/Phase, Crosstalk, Off-Isolation

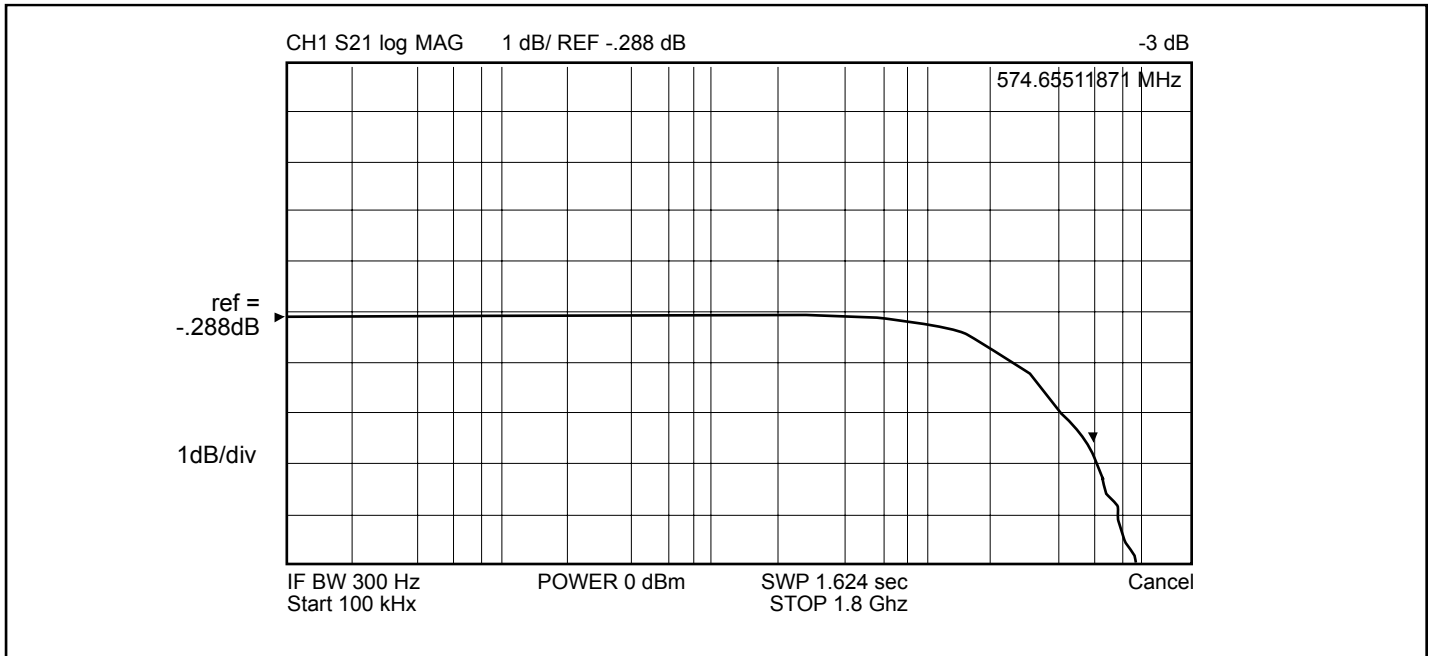

Figure 3. Bandwidth @ -3dB

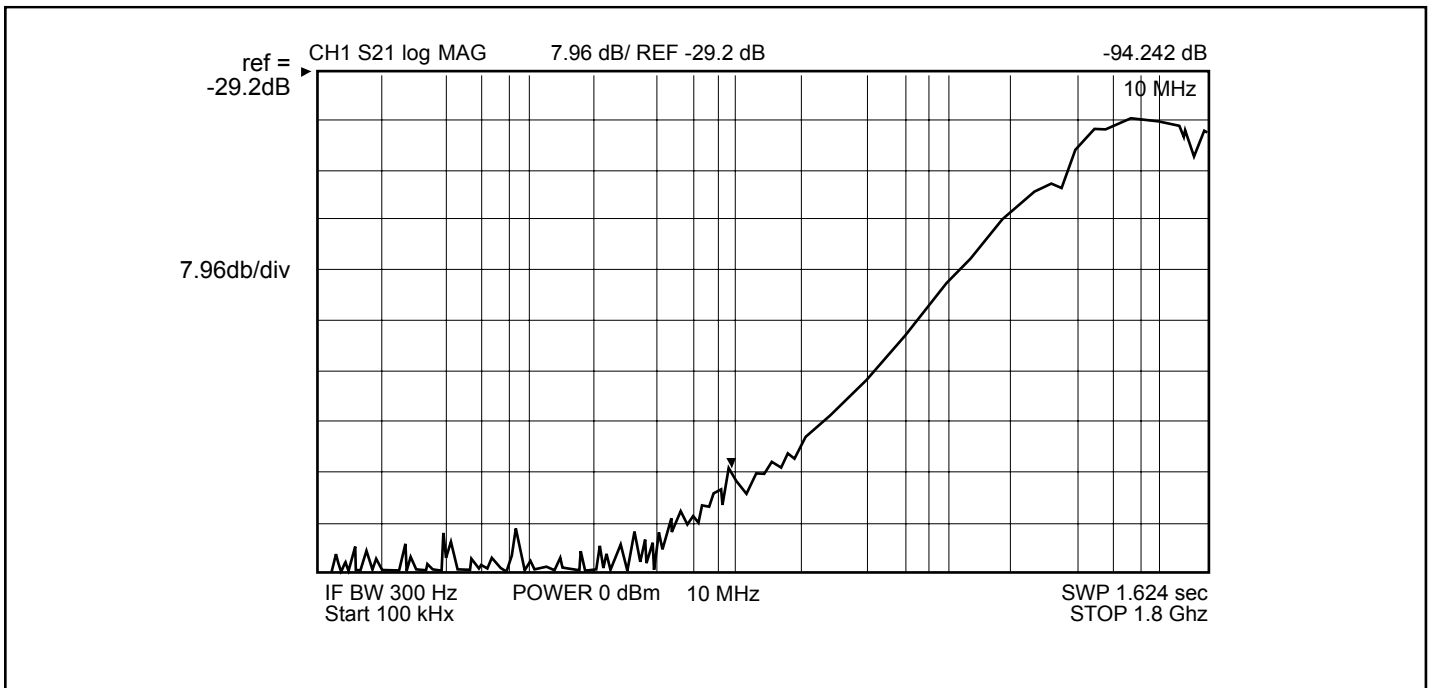

Figure 4. Crosstalk @ 25°C, V_{CC} = 4.75V

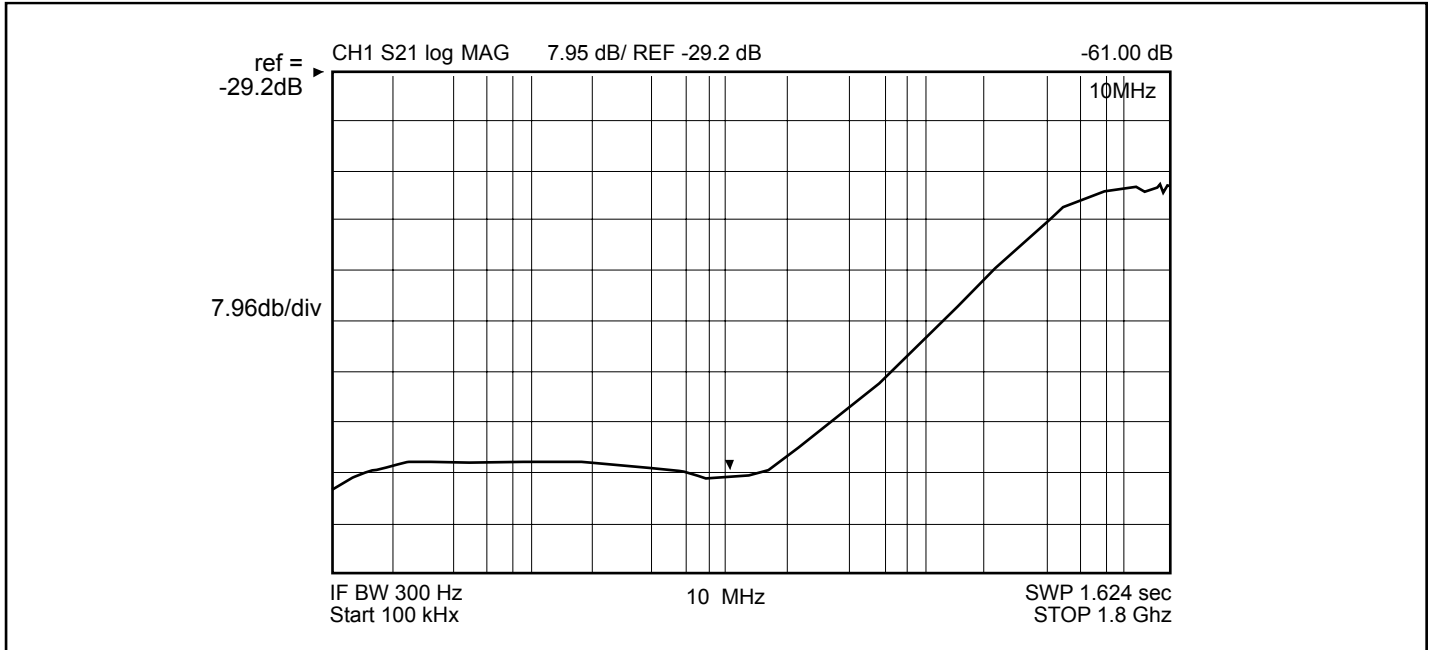

Figure 5. Off Isolation, 25°C $V_{CC} = 4.75$

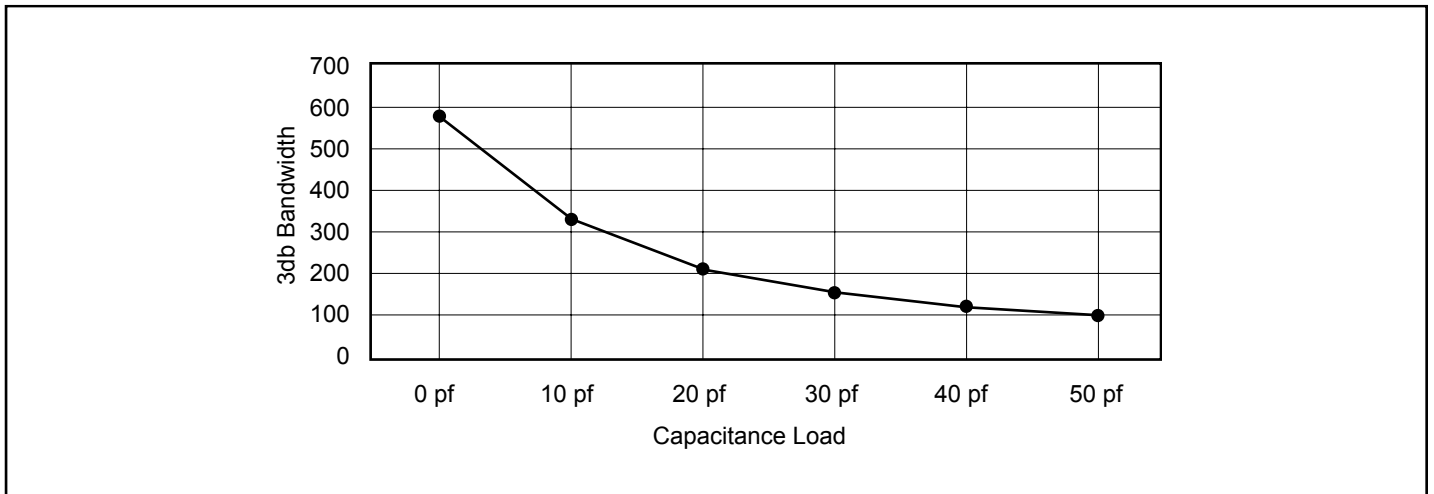
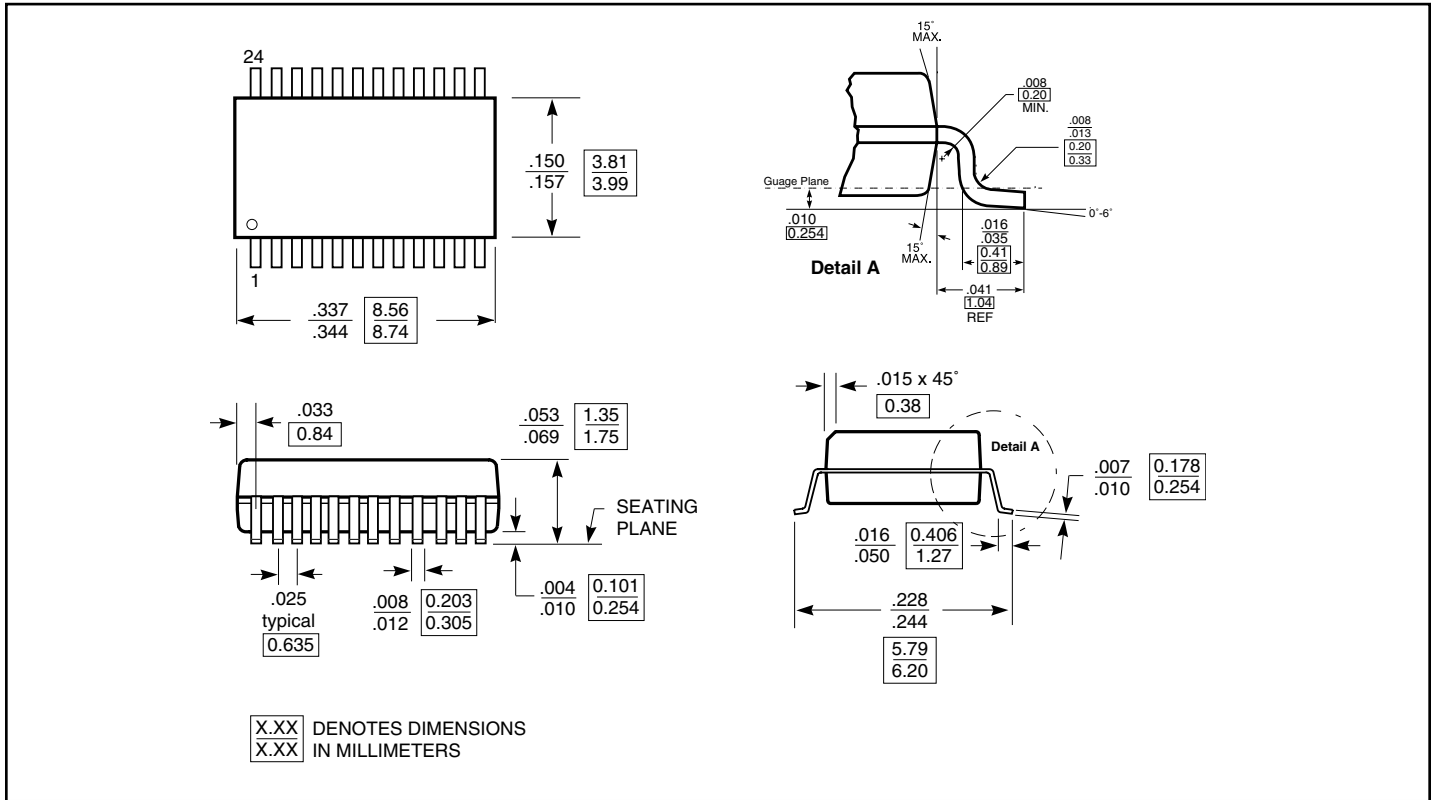

Figure 6. Bandwidth vs Capacitance

Packaging Mechanical: 24-pin QSOP (Q)



Ordering Information

Ordering Code	Package Code	Package Description
PI5V512Q	Q	24-pin 150-mil wide plastic QSOP
PI5V512QE	Q	Pb-free & Green, 24-pin 150-mil wide plastic QSOP

Notes:

- Thermal characteristics can be found on the company web site at www.pericom.com/packaging/

Looking for pricing, stock, or lifecycle information?

Click below to explore more details on WIN SOURCE:

 [View PI5V512QE on WIN SOURCE](#)

 [Diodes Incorporated](#) Information

Optimize Your Supply Chain with WIN SOURCE Solutions

-  Global Sourcing Solution
-  Obsolete Management
-  Cost Control Management
-  Shortage Management
-  Alternative Solution
-  Excess Inventory Management