



# THE DATASHEET OF TLC5940QPWPREP



# TLC5940-EP 16-Channel LED Driver With Dot Correction and Grayscale PWM Control

## 1 Features

- 16 Channels
- 12-Bit (4096 Steps) Grayscale PWM Control
- Dot Correction
  - 6 Bit (64 Steps)
  - Storable in Integrated EEPROM
- Drive Capability (Constant-Current Sink) of 0 mA to 72 mA (–40°C to 125°C)
  - 0 mA to 60 mA ( $V_{CC} < 3.6\text{ V}$ , –40°C to 85°C)
  - 0 mA to 120 mA ( $V_{CC} > 3.6\text{ V}$ , –40°C to 85°C)
- LED Power Supply Voltage up to 17 V
- $V_{CC} = 3\text{ V}$  to 5.5 V
- Serial Data Interface
- Controlled In-Rush Current
- 30-MHz Data Transfer Rate
- CMOS Level I/O
- Error Information
  - LOD: LED Open Detection
  - TEF: Thermal Error Flag

## 2 Applications

- Monocolor, Multicolor, Full-Color LED Displays
- LED Signboards
- Display Backlighting
- General, High-Current LED Drive
- Supports Defense, Aerospace, and Medical Applications:
  - Controlled Baseline
  - One Assembly/Test Site
  - One Fabrication Site
  - Available in Q-Temp (–40°C/125°C)
  - Extended Product Life Cycle
  - Extended Product-Change Notification
  - Product Traceability

## 3 Description

The TLC5940-EP is a 16-channel, constant-current sink LED driver. Each channel has an individually adjustable 4096-step grayscale PWM brightness control and a 64-step, constant-current sink (dot correction). The dot correction adjusts the brightness variations between LED channels and other LED drivers. The dot correction data is stored in an integrated EEPROM. Both grayscale control and dot correction are accessible via a serial interface. A single external resistor sets the maximum current value of all 16 channels.

The TLC5940-EP features two error information circuits. The LED open detection (LOD) indicates a broken or disconnected LED at an output terminal. The thermal error flag (TEF) indicates an overtemperature condition.

### Device Information<sup>(1)</sup>

PART NUMBER	PACKAGE	BODY SIZE (NOM)
TLC5940-EP	HTSSOP (28)	9.70 mm x 4.40 mm
	VQFN (32)	5.00 mm x 5.00 mm

(1) For all available packages, see the orderable addendum at the end of the data sheet.

### Simplified Schematic

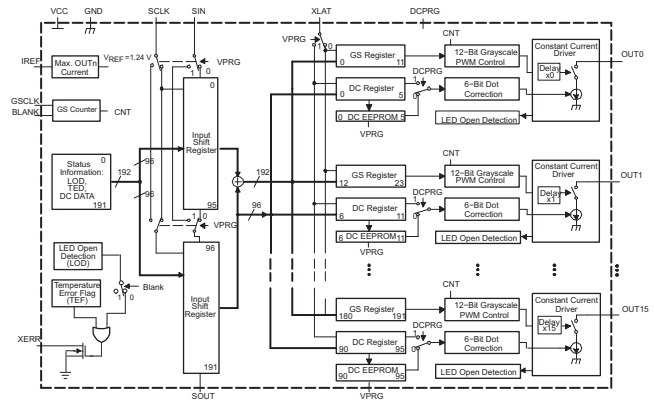

## Table of Contents

<b>1 Features</b> .....	<b>1</b>	8.3 Feature Description .....	<b>14</b>
<b>2 Applications</b> .....	<b>1</b>	8.4 Device Functional Modes .....	<b>18</b>
<b>3 Description</b> .....	<b>1</b>	<b>9 Application and Implementation</b> .....	<b>23</b>
<b>4 Revision History</b> .....	<b>2</b>	9.1 Application Information .....	<b>23</b>
<b>5 Pin Configuration and Functions</b> .....	<b>3</b>	9.2 Typical Application .....	<b>23</b>
<b>6 Specifications</b> .....	<b>5</b>	<b>10 Power Supply Recommendations</b> .....	<b>25</b>
6.1 Absolute Maximum Ratings .....	<b>5</b>	<b>11 Layout</b> .....	<b>25</b>
6.2 ESD Ratings .....	<b>5</b>	11.1 Layout Guidelines .....	<b>25</b>
6.3 Recommended Operating Conditions .....	<b>5</b>	11.2 Layout Example .....	<b>25</b>
6.4 Thermal Information .....	<b>6</b>	11.3 Power Dissipation Calculation .....	<b>26</b>
6.5 Electrical Characteristics .....	<b>6</b>	<b>12 Device and Documentation Support</b> .....	<b>27</b>
6.6 Switching Characteristics .....	<b>8</b>	12.1 Receiving Notification of Documentation Updates .....	<b>27</b>
6.7 Typical Characteristics .....	<b>9</b>	12.2 Community Resources .....	<b>27</b>
<b>7 Parameter Measurement Information</b> .....	<b>11</b>	12.3 Trademarks .....	<b>27</b>
7.1 Test Parameter Equations .....	<b>13</b>	12.4 Electrostatic Discharge Caution .....	<b>27</b>
<b>8 Detailed Description</b> .....	<b>14</b>	12.5 Glossary .....	<b>27</b>
8.1 Overview .....	<b>14</b>	<b>13 Mechanical, Packaging, and Orderable Information</b> .....	<b>27</b>
8.2 Functional Block Diagram .....	<b>14</b>		

## 4 Revision History

NOTE: Page numbers for previous revisions may differ from page numbers in the current version.

<b>Changes from Revision D (May 2010) to Revision E</b>	<b>Page</b>
• Added <i>ESD Ratings</i> table, <i>Feature Description</i> section, <i>Device Functional Modes</i> , <i>Application and Implementation</i> section, <i>Power Supply Recommendations</i> section, <i>Layout</i> section, <i>Device and Documentation Support</i> section, and <i>Mechanical, Packaging, and Orderable Information</i> section .....	<b>1</b>
• Deleted <i>Ordering Information</i> table; see POA at the end of the data sheet .....	<b>1</b>
• Changed thermal values for RHB (VQFN) package: 33.9 to 36.7 for $R_{\theta JA}$ , 30 to 18.9 for $R_{\theta JC(top)}$ , 9.3 to 15.9 for $R_{\theta JB}$ , 0.619 to 0.6 for $\psi_{JT}$ , 9.3 to 15.8 for $\psi_{JB}$ , and 3.9 to 2.3 for $R_{\theta JC(bot)}$ .....	<b>6</b>
• Changed thermal values for PWP (HTSSOP) package: 35.4 to 34.3 for $R_{\theta JA}$ , 24.94 to 36.8 for $R_{\theta JC(top)}$ , 15.02 to 8.5 for $R_{\theta JB}$ , 1.297 to 0.3 for $\psi_{JT}$ , 10.96 to 8.7 for $\psi_{JB}$ , and 5.37 to 1.6 for $R_{\theta JC(bot)}$ .....	<b>6</b>
• Deleted <i>Dissipation Ratings</i> table .....	<b>6</b>

<b>Changes from Revision B (September 2007) to Revision C</b>	<b>Page</b>
• Changed from ms to ns .....	<b>6</b>

## 5 Pin Configuration and Functions

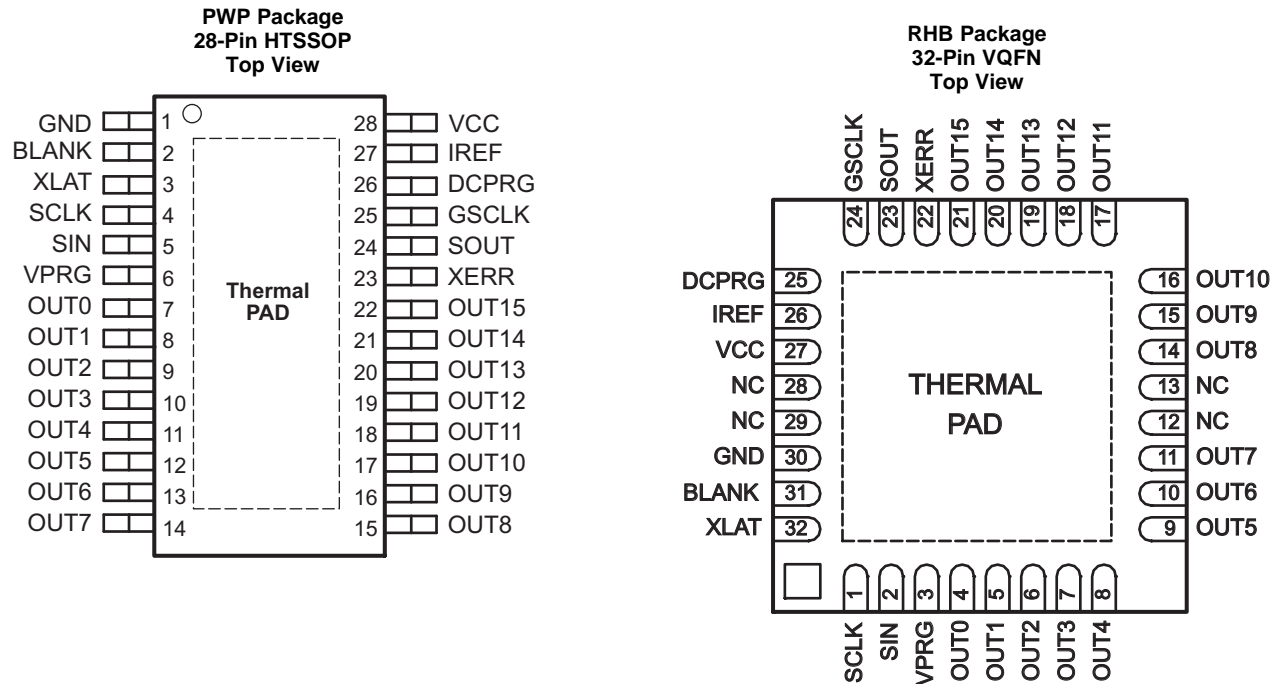

### Pin Functions

NAME	PIN		I/O	DESCRIPTION
	HTSSOP	VQFN		
BLANK	2	31	I	Blank all outputs. When BLANK = H, all OUTn outputs are forced OFF. GS counter is also reset. When BLANK = L, OUTn are controlled by grayscale PWM control.
DCPRG	26	25	I	Switch DC data input. When DCPRG = L, DC is connected to EEPROM. When DCPRG = H, DC is connected to the DC register. DCPRG also controls EEPROM writing, when VPRG = V <sub>(PRG)</sub> . EEPROM data = 3Fh (default)
GND	1	30	G	Ground
GSCLK	25	24	I	Reference clock for grayscale PWM control
IREF	27	26	I	Reference current terminal
NC	—	12, 13, 28, 29	—	No connection
OUT0	7	4	O	Constant current output
OUT1	8	5	O	Constant current output
OUT2	9	6	O	Constant current output
OUT3	10	7	O	Constant current output
OUT4	11	8	O	Constant current output
OUT5	12	9	O	Constant current output
OUT6	13	10	O	Constant current output
OUT7	14	11	O	Constant current output
OUT8	15	14	O	Constant current output
OUT9	16	15	O	Constant current output
OUT10	17	16	O	Constant current output
OUT11	18	17	O	Constant current output
OUT12	19	18	O	Constant current output
OUT13	20	19	O	Constant current output

**Pin Functions (continued)**

PIN			I/O	DESCRIPTION
NAME	HTSSOP	VQFN		
OUT14	21	20	O	Constant current output
OUT15	22	21	O	Constant current output
SCLK	4	1	I	Serial data shift clock
SIN	5	2	I	Serial data input
SOUT	24	23	O	Serial data output
VCC	28	27	I	Power supply voltage
VPRG	6	3	I	Multifunction input pin. When VPRG = GND, the device is in GS mode. When VPRG = V <sub>CC</sub> , the device is in DC mode. When VPRG = V <sub>(VPRG)</sub> , DC register data can be programmed into DC EEPROM with DCPRG=HIGH. EEPROM data = 3Fh (default)
XERR	23	22	O	Error output. XERR is an open-drain terminal. XERR goes L when LOD or TEF is detected.
XLAT	3	32	I	Level triggered latch signal. When XLAT = high, the TLC5940-EP writes data from the input shift register to either GS register (VPRG = low) or DC register (VPRG = high). When XLAT = low, the data in GS or DC register is held constant.

## 6 Specifications

### 6.1 Absolute Maximum Ratings

over operating free-air temperature range (unless otherwise noted)<sup>(1) (2)</sup>

		MIN	MAX	UNIT
Input voltage <sup>(3)</sup>	V <sub>CC</sub>	-0.3	6	V
	V <sub>(BLANK)</sub> , V <sub>(DCPRG)</sub> , V <sub>(SCLK)</sub> , V <sub>(XLAT)</sub> , V <sub>(SIN)</sub> , V <sub>(GSCLK)</sub> , V <sub>(IREF)</sub>	-0.3	V <sub>CC</sub> + 0.3	V
Output voltage	V <sub>(SOUT)</sub> , V <sub>(XERR)</sub>	-0.3	V <sub>CC</sub> + 0.3	V
	V <sub>(OUT0)</sub> to V <sub>(OUT15)</sub>	-0.3	18	V
Output current (dc)	I <sub>O</sub>		130	mA
EEPROM program	V <sub>(VPRG)</sub>	-0.3	24	V
EEPROM write cycles			25	
Package thermal impedance		See <a href="#">Thermal Information</a>		
Operating ambient temperature, T <sub>A</sub>		-40	125	°C
Storage temperature, T <sub>stg</sub>		-55	150	°C

- (1) Stresses beyond those listed under *Absolute Maximum Ratings* may cause permanent damage to the device. These are stress ratings only, and functional operation of the device at these or any other conditions beyond those indicated under *Recommended Operating Conditions* is not implied. Exposure to absolute maximum rated conditions for extended periods may affect device reliability.
- (2) Long-term high-temperature storage and/or extended use at maximum recommended operating conditions may result in a reduction of overall device life. See [www.ti.com/ep\\_quality](http://www.ti.com/ep_quality) for additional information on enhanced plastic packaging.
- (3) All voltage values are with respect to network ground terminal.

### 6.2 ESD Ratings

		VALUE	UNIT
V <sub>(ESD)</sub> Electrostatic discharge	Human body model (HBM), per ANSI/ESDA/JEDEC JS-001, all pins <sup>(1)</sup>	±2000	V
	Charged device model (CDM), per JEDEC specification JESD22-C101, all pins <sup>(2)</sup>	±500	

- (1) JEDEC document JEP155 states that 500-V HBM allows safe manufacturing with a standard ESD control process.
- (2) JEDEC document JEP157 states that 250-V CDM allows safe manufacturing with a standard ESD control process.

### 6.3 Recommended Operating Conditions

		MIN	NOM	MAX	UNIT
<b>DC CHARACTERISTICS</b>					
V <sub>CC</sub>	Supply Voltage	3		5.5	V
V <sub>O</sub>	Voltage applied to output (OUT0–OUT15)			17	V
V <sub>IH</sub>	High-level input voltage	0.8 V <sub>CC</sub>		V <sub>CC</sub>	V
V <sub>IL</sub>	Low-level input voltage	GND		0.2 V <sub>CC</sub>	V
I <sub>OH</sub>	High-level output current	V <sub>CC</sub> = 5 V at SOUT		-1	mA
I <sub>OL</sub>	Low-level output current	V <sub>CC</sub> = 5 V at SOUT		1	mA
I <sub>OLC</sub>	Constant output current	OUT0 to OUT15	-40°C to 125°C	72	mA
			-40°C to 85°C, V <sub>CC</sub> < 3.6 V	60	
			-40°C to 85°C, V <sub>CC</sub> > 3.6 V	120	
V <sub>(VPRG)</sub>	EEPROM program voltage	20	22	23	V
T <sub>A</sub>	Operating free-air temperature	-40		125	°C
<b>AC CHARACTERISTICS</b> <sup>(1)</sup>					
f <sub>(SCLK)</sub>	Data shift clock frequency	SCLK		30	MHz
f <sub>(GSCLK)</sub>	Grayscale clock frequency	GSCLK		30	MHz
t <sub>wh0</sub> /t <sub>w0</sub>	SCLK pulse duration	SCLK = H/L (see <a href="#">Figure 12</a> )		16	ns
t <sub>wh1</sub> /t <sub>w1</sub>	GSCLK pulse duration	GSCLK = H/L (see <a href="#">Figure 12</a> )		16	ns
t <sub>wh2</sub>	XLAT pulse duration	XLAT = H (see <a href="#">Figure 12</a> )		20	ns

- (1) V<sub>CC</sub> = 3 V to 5.5 V, T<sub>A</sub> = -40°C to 125°C (unless otherwise noted)

**Recommended Operating Conditions (continued)**

			MIN	NOM	MAX	UNIT
$t_{wh3}$	BLANK pulse duration	BLANK = H (see <a href="#">Figure 12</a> )	20			ns
$t_{su0}$	Setup time	SIN to SCLK $\uparrow^{(2)}$ (see <a href="#">Figure 12</a> )	5			ns
$t_{su1}$		SCLK $\downarrow$ to XLAT $\uparrow$ (see <a href="#">Figure 12</a> )	10			ns
$t_{su2}$		VPRG $\uparrow\downarrow$ to SCLK $\uparrow$ (see <a href="#">Figure 12</a> )	10			ns
$t_{su3}$		VPRG $\uparrow\downarrow$ XLAT $\uparrow$ (see <a href="#">Figure 12</a> )	10			ns
$t_{su4}$		BLANK $\downarrow$ to GSCLK $\uparrow$ (see <a href="#">Figure 12</a> )	10			ns
$t_{su5}$		XLAT $\uparrow$ to GSCLK $\uparrow$ (see <a href="#">Figure 12</a> )	30			ns
$t_{su6}$		VPRG $\uparrow$ to DCPRG $\uparrow$ (see <a href="#">Figure 17</a> )	1			ms
$t_{h0}$	Hold time	SCLK $\uparrow$ to SIN (see <a href="#">Figure 12</a> )	3			ns
$t_{h1}$		XLAT $\downarrow$ to SCLK $\uparrow$ (see <a href="#">Figure 12</a> )	10			ns
$t_{h2}$		SCLK $\uparrow$ to VPRG $\uparrow\downarrow$ (see <a href="#">Figure 12</a> )	10			ns
$t_{h3}$		XLAT $\downarrow$ to VPRG $\uparrow\downarrow$ (see <a href="#">Figure 12</a> )	10			ns
$t_{h4}$		GSCLK $\uparrow$ to BLANK $\uparrow$ (see <a href="#">Figure 12</a> )	10			ns
$t_{h5}$		DCPRG $\downarrow$ to VPRG $\downarrow$ (see <a href="#">Figure 12</a> )	1			ms
$t_{prog}$	Programming time for EEPROM (see <a href="#">Figure 17</a> )		20			ms

(2)  $\uparrow$  and  $\downarrow$  indicates a rising edge, and a falling edge respectively.

**6.4 Thermal Information**

THERMAL METRIC <sup>(1)</sup>		TLC5940-EP		UNIT
		RHB (VQFN)	PWP (HTSSOP)	
		32 PINS	28 PINS	
$R_{\theta JA}$	Junction-to-ambient thermal resistance	36.7	34.3	°C/W
$R_{\theta JC(top)}$	Junction-to-case (top) thermal resistance	18.9	36.8	°C/W
$R_{\theta JB}$	Junction-to-board thermal resistance	15.9	8.5	°C/W
$\Psi_{JT}$	Junction-to-top characterization parameter	0.6	0.3	°C/W
$\Psi_{JB}$	Junction-to-board characterization parameter	15.8	8.7	°C/W
$R_{\theta JC(bot)}$	Junction-to-case (bottom) thermal resistance	2.3	1.6	°C/W

(1) For more information about traditional and new thermal metrics, see the [Semiconductor and IC Package Thermal Metrics](#) application report.

**6.5 Electrical Characteristics**

$V_{CC} = 3\text{ V to }5.5\text{ V}$ ,  $T_A = -40^\circ\text{C to }125^\circ\text{C}$  (unless otherwise noted)

PARAMETER	TEST CONDITIONS	MIN	TYP	MAX	UNIT	
$V_{OH}$	High-level output voltage	$I_{OH} = -1\text{ mA}$ , SOUT			V	
$V_{OL}$	Low-level output voltage	$I_{OL} = 1\text{ mA}$ , SOUT			V	
$I_I$	Input current	$V_I = V_{CC}$ or GND; BLANK, DCPRG, GSCLK, SCLK, SIN, XLAT			$\mu\text{A}$	
		$V_I = \text{GND}$ ; VPRG				
		$V_I = V_{CC}$ ; VPRG			50	
		$V_I = 21\text{ V}$ ; VPRG; DCPRG = $V_{CC}$			4 10	mA
$I_{CC}$	Supply current	No data transfer, all output OFF, $V_O = 1\text{ V}$ , $R_{(IREF)} = 10\text{ k}\Omega$			mA	
		No data transfer, all output OFF, $V_O = 1\text{ V}$ , $R_{(IREF)} = 1.3\text{ k}\Omega$				
		Data transfer 30 MHz, all output ON, $V_O = 1\text{ V}$ , $R_{(IREF)} = 1.3\text{ k}\Omega$				16
		Data transfer 30 MHz, all output ON, $V_O = 1\text{ V}$ , $R_{(IREF)} = 640\ \Omega$				30

## Electrical Characteristics (continued)

 $V_{CC} = 3\text{ V to }5.5\text{ V}$ ,  $T_A = -40^\circ\text{C to }125^\circ\text{C}$  (unless otherwise noted)

PARAMETER		TEST CONDITIONS	MIN	TYP	MAX	UNIT
$I_{O(LC)}$	Constant sink current (see <a href="#">Figure 10</a> )	All output ON, $V_O = 1\text{ V}$ , $R_{(IREF)} = 640\ \Omega$ , $25^\circ\text{C}$	54	61	69	mA
		All output ON, $V_O = 1\text{ V}$ , $R_{(IREF)} = 640\ \Omega$ , Full temperature	42	61	72	
$I_{lkg}$	Leakage output current	All output OFF, $V_O = 15\text{ V}$ , $R_{(IREF)} = 640\ \Omega$ , OUT0 to OUT15			$\pm 1$	$\mu\text{A}$
$\Delta I_{O(LC0)}$	Constant sink current error (see <a href="#">Figure 10</a> )	All output ON, $V_O = 1\text{ V}$ , $R_{(IREF)} = 640\ \Omega$ , OUT0 to OUT15, $25^\circ\text{C}$			$\pm 4\%$	
		All output ON, $V_O = 1\text{ V}$ , $R_{(IREF)} = 640\ \Omega$ , OUT0 to OUT15 <sup>(1)</sup> , Full temperature			$\pm 12\%$	
		All output ON, $V_O = 1\text{ V}$ , $R_{(IREF)} = 1300\ \Omega$ , OUT0 to OUT15, $25^\circ\text{C}$			$\pm 4\%$	
		All output ON, $V_O = 1\text{ V}$ , $R_{(IREF)} = 1300\ \Omega$ , OUT0 to OUT15 <sup>(1)</sup> , Full temperature			$\pm 8\%$	
$\Delta I_{O(LC1)}$	Constant sink current error (see <a href="#">Figure 10</a> )	Device to device, Averaged current from OUT0 to OUT15, $R_{(IREF)} = 1920\ \Omega$ (20 mA) <sup>(2)</sup>		-2%		
					0.4%	
$\Delta I_{O(LC2)}$	Constant sink current error (see <a href="#">Figure 10</a> )	Device to device, Averaged current from OUT0 to OUT15, $R_{(IREF)} = 480\ \Omega$ (80 mA) <sup>(2)</sup>		-2.7%		
					2%	
$\Delta I_{O(LC3)}$	Line regulation (see <a href="#">Figure 10</a> )	All output ON, $V_O = 1\text{ V}$ , $R_{(IREF)} = 640\ \Omega$ , OUT0 to OUT15 <sup>(3)</sup> , $25^\circ\text{C}$			$\pm 4$	%V
		All output ON, $V_O = 1\text{ V}$ , $R_{(IREF)} = 640\ \Omega$ , OUT0 to OUT15 <sup>(3)</sup> , Full temperature			$\pm 11$	
		All output ON, $V_O = 1\text{ V}$ , $R_{(IREF)} = 1300\ \Omega$ , OUT0 to OUT15 <sup>(3)</sup> , $25^\circ\text{C}$			$\pm 4$	
		All output ON, $V_O = 1\text{ V}$ , $R_{(IREF)} = 1300\ \Omega$ , OUT0 to OUT15 <sup>(3)</sup> , Full temperature			$\pm 4$	
$\Delta I_{O(LC4)}$	Load regulation (see <a href="#">Figure 10</a> )	All output ON, $V_O = 1\text{ V to }3\text{ V}$ , $R_{(IREF)} = 640\ \Omega$ , OUT0 to OUT15 <sup>(4)</sup> , $25^\circ\text{C}$			$\pm 6$	%V
		All output ON, $V_O = 1\text{ V to }3\text{ V}$ , $R_{(IREF)} = 640\ \Omega$ , OUT0 to OUT15 <sup>(4)</sup> , Full temperature			$\pm 20$	
		All output ON, $V_O = 1\text{ V to }3\text{ V}$ , $R_{(IREF)} = 1300\ \Omega$ , OUT0 to OUT15 <sup>(4)</sup> , $25^\circ\text{C}$			$\pm 6$	
		All output ON, $V_O = 1\text{ V to }3\text{ V}$ , $R_{(IREF)} = 1300\ \Omega$ , OUT0 to OUT15 <sup>(4)</sup> , Full temperature			$\pm 6$	
$T_{(TEF)}$	Thermal error flag threshold	Junction temperature <sup>(5)</sup>	150		170	$^\circ\text{C}$
$V_{(LED)}$	LED open detection threshold			0.3	0.4	V
$V_{(IREF)}$	Reference voltage output	$R_{(IREF)} = 640\ \Omega$	1.2	1.24	1.28	V

(1) The deviation of each output from the average of OUT0-15 constant current. It is calculated by [Equation 1](#).

(2) The deviation of average of OUT1-15 constant current from the ideal constant-current value. It is calculated by [Equation 2](#). The ideal current is calculated by [Equation 3](#).

(3) The line regulation is calculated by [Equation 4](#).

(4) The load regulation is calculated by [Equation 5](#).

(5) Not tested. Specified by design

## 6.6 Switching Characteristics

 $V_{CC} = 3\text{ V to }5.5\text{ V}$ ,  $T_A = -40^\circ\text{C to }125^\circ\text{C}$  (unless otherwise noted)

PARAMETER		TEST CONDITIONS	MIN	TYP	MAX	UNIT
$t_{r0}$	Rise time	SOUT			16	ns
$t_{r1}$		OUTn, $V_{CC} = 5\text{ V}$ , $T_A = 60^\circ\text{C}$ , DCn = 3 Fh		10	30	
$t_{f0}$	Fall time	SOUT			16	ns
$t_{f1}$		OUTn, $V_{CC} = 5\text{ V}$ , $T_A = 60^\circ\text{C}$ , DCn = 3 Fh		10	30	
$t_{pd0}$	Propagation delay time	SCLK to SOUT (see <a href="#">Figure 12</a> )			30	ns
$t_{pd1}$		BLANK to OUT0			60	ns
$t_{pd2}$		OUTn to XERR (see <a href="#">Figure 12</a> )			1000	ns
$t_{pd3}$		GSCLK to OUT0 (see <a href="#">Figure 12</a> )			60	ns
$t_{pd4}$		XLAT to I <sub>OUT</sub> (dot correction) (see <a href="#">Figure 12</a> )			60	ns
$t_{pd5}$		DCPRG to OUT0 (see <a href="#">Figure 12</a> )			30	ns
$t_d$	Output delay time	OUTn to OUT(n+1) (see <a href="#">Figure 12</a> )		20	30	ns
$t_{on-err}$	Output on-time error	$t_{outon} - T_{gsclk}$ (see <a href="#">Figure 12</a> ), GS <sub>n</sub> = 01 h, GSCLK = 11 MHz	10	-50	-90	ns

### 6.7 Typical Characteristics

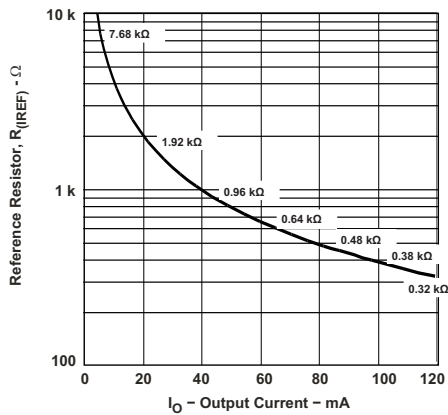

Figure 1. Reference Resistor vs Output Current

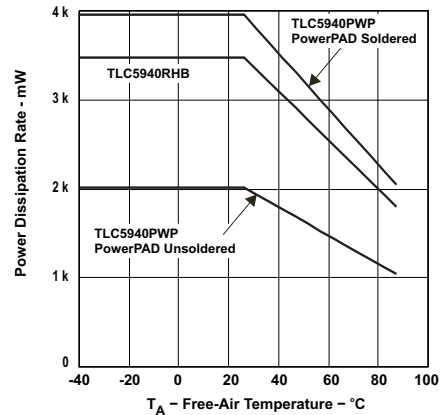

Figure 2. Power Dissipation Rate vs Free-Air Temperature

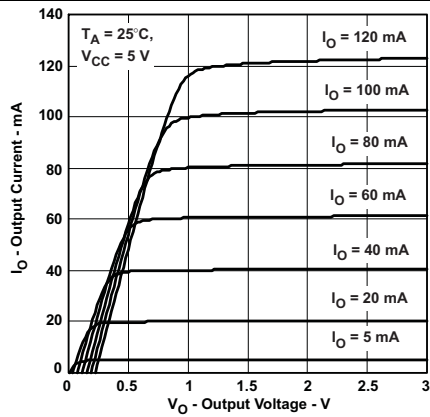

Figure 3. Output Current vs Output Voltage

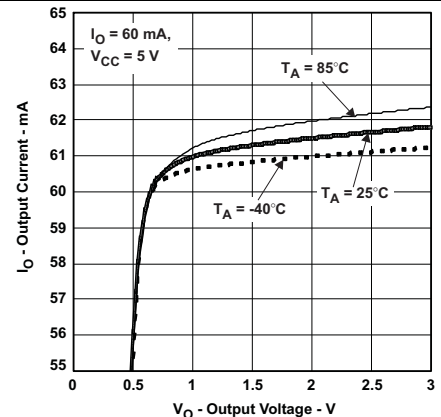

Figure 4. Output Current vs Output Voltage

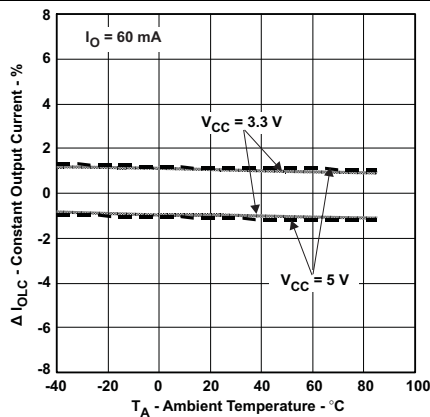

Figure 5. Constant Output Current,  $\Delta I_{OLC}$  vs Ambient Temperature

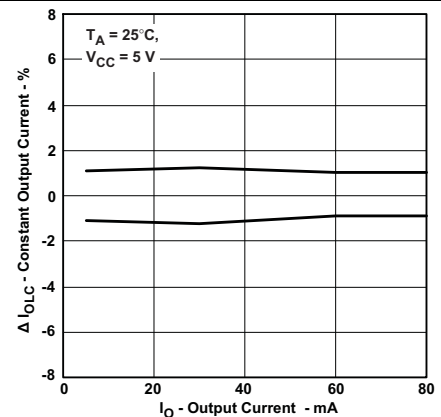
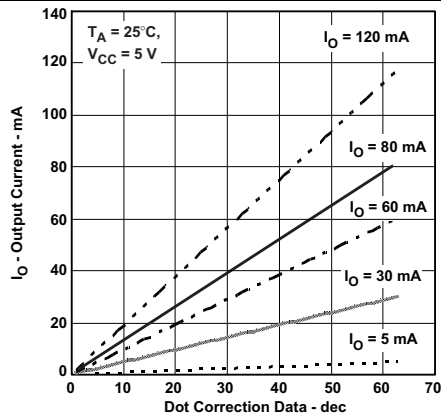
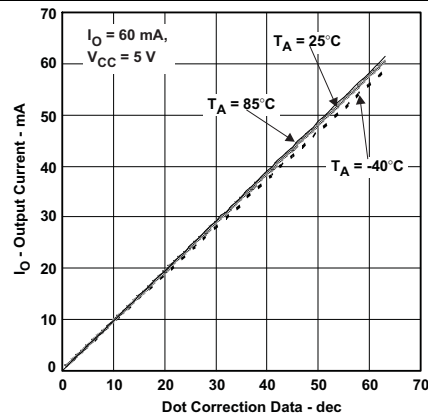

Figure 6. Constant Output Current,  $\Delta I_{OLC}$  vs Output Current

**Typical Characteristics (continued)**



**Figure 7. Output Current vs DOT Correction Linearity (ABS Value)**



**Figure 8. Output Current vs DOT Correction Linearity (ABS Value)**

## 7 Parameter Measurement Information

Resistor values are equivalent resistances, and they are not tested.

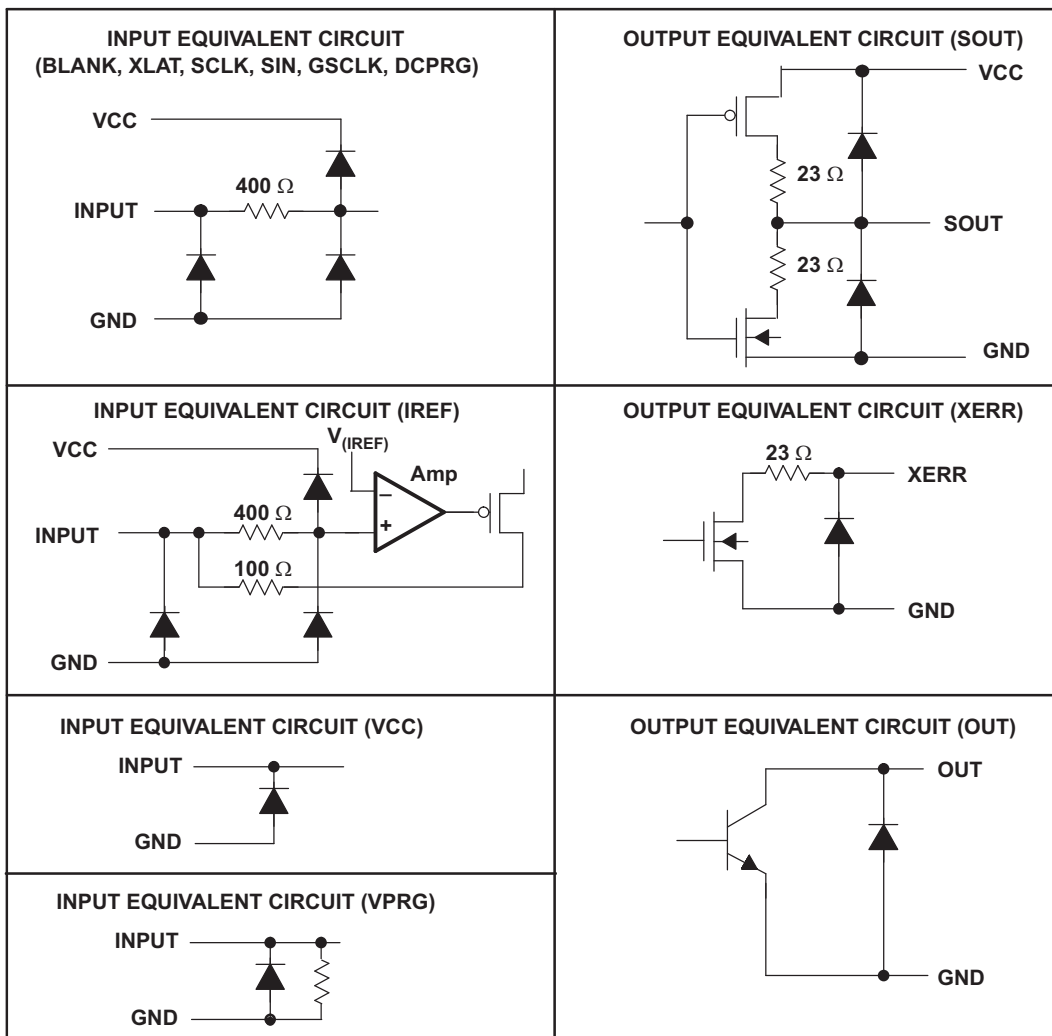
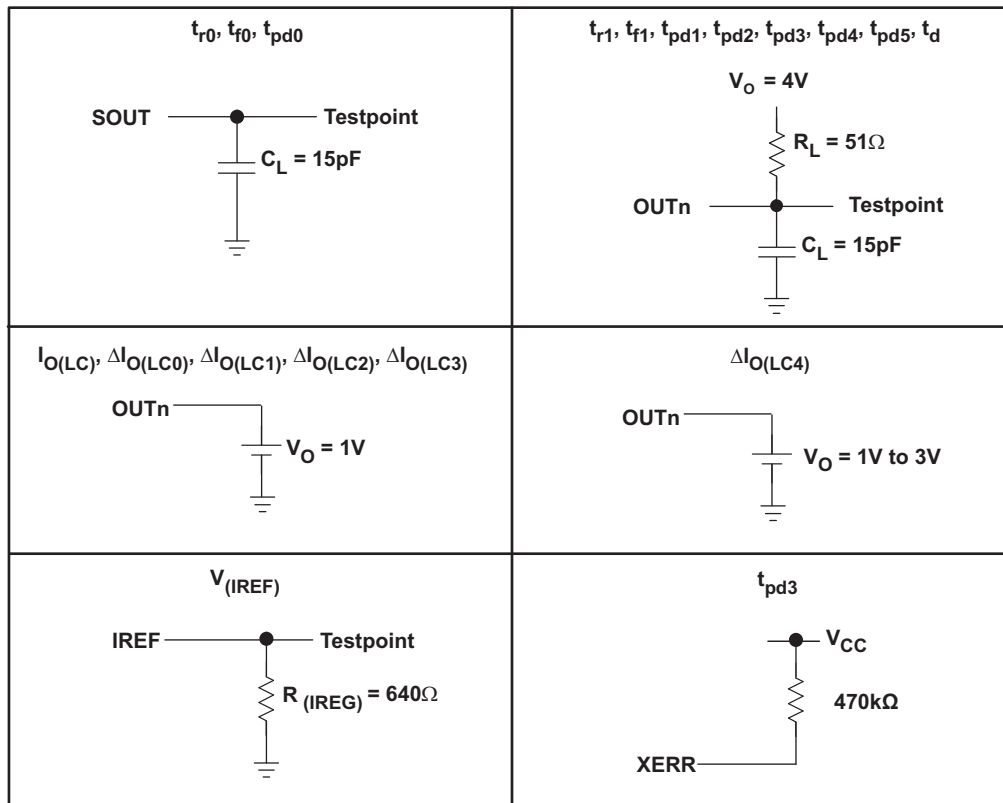
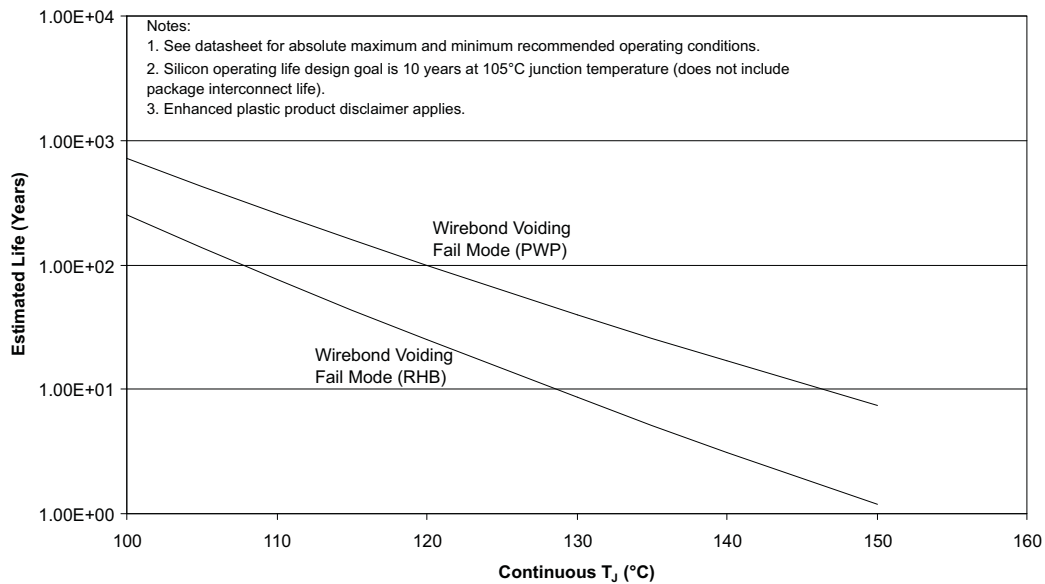

Figure 9. Input and Output Equivalent Circuits

**Parameter Measurement Information (continued)**



**Figure 10. Parameter Measurement Circuits**



**Figure 11. TLC5940-EP Mold Compound Operating Life**

## 7.1 Test Parameter Equations

$$\Delta(\%) = \frac{I_{OUTn} - I_{OUTavg\_0-15}}{I_{OUTavg\_0-15}} \times 100 \quad (1)$$

$$\Delta(\%) = \frac{I_{OUTavg} - I_{OUT(IDEAL)}}{I_{OUT(IDEAL)}} \times 100 \quad (2)$$

$$I_{OUT(IDEAL)} = 31.5 \times \left( \frac{1.24V}{R_{IREF}} \right) \quad (3)$$

$$\Delta(\% / V) = \frac{(I_{OUTn} \text{ at } V_{CC} = 5.5V) - (I_{OUTn} \text{ at } V_{CC} = 3.0V)}{(I_{OUTn} \text{ at } V_{CC} = 3.0V)} \times \frac{100}{2.5} \quad (4)$$

$$\Delta(\% / V) = \frac{(I_{OUTn} \text{ at } V_{OUTn} = 3.0V) - (I_{OUTn} \text{ at } V_{OUTn} = 1.0V)}{(I_{OUTn} \text{ at } V_{OUTn} = 1.0V)} \times \frac{100}{2.0} \quad (5)$$

## 8 Detailed Description

### 8.1 Overview

The TLC5940-EP is a 16-channel constant current sink driver. Each channel has an individually-adjustable, 4096-step, pulse width modulation (PWM), grayscale (GS) brightness control, and a 64-step dot correction brightness control. GS data and DC data are input via a serial interface port. The dot correction data is stored in an integrated EEPROM. The TLC5940-EP has a 120-mA current capability. The maximum current value of all channels is determined by an external resistor. The TLC5940-EP has a LED open detection (LOD) function that indicates a broken or disconnected LED at an output terminal and a thermal error flag (TEF) indicates an overtemperature condition.

### 8.2 Functional Block Diagram

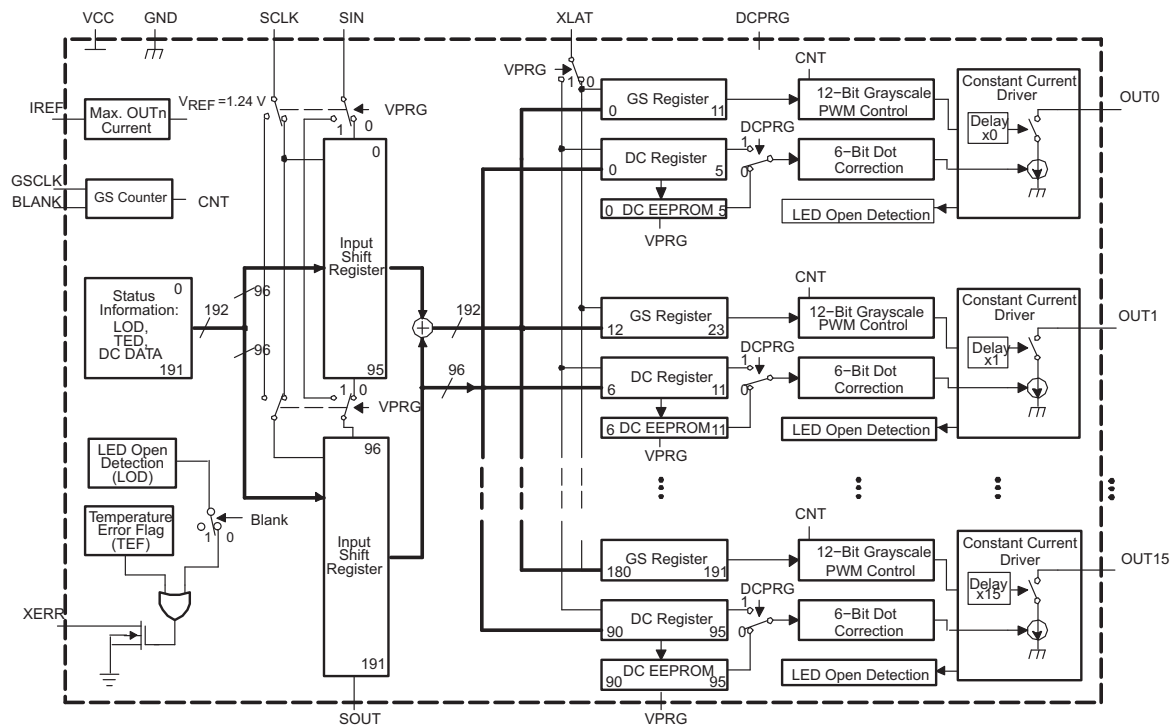

### 8.3 Feature Description

#### 8.3.1 Serial Interface

The TLC5940-EP has a flexible serial interface, which can be connected to microcontrollers or digital signal processors in various ways. Only 3 pins are needed to input data into the device. The rising edge of SCLK signal shifts the data from the SIN pin to the internal register. After all data is clocked in, a high-level pulse of XLAT signal latches the serial data to the internal registers. The internal registers are level-triggered latches of XLAT signal. All data are clocked in with the MSB first. The length of serial data is 96 bit or 192 bit, depending on the programming mode. Grayscale data and dot correction data can be entered during a grayscale cycle. Although new grayscale data can be clocked in during a grayscale cycle, the XLAT signal should only latch the grayscale data at the end of the grayscale cycle. Latching in new grayscale data immediately overwrites the existing grayscale data. Figure 12 shows the timing chart. More than two TLC5940-EPs can be connected in series by connecting an SOUT pin from one device to the SIN pin of the next device. An example of cascading two TLC5940-EPs is shown in Figure 13 and the timing chart is shown in Figure 14. The SOUT pin can also be connected to the controller to receive status information from TLC5940-EP as shown in Figure 23.



Feature Description (continued)

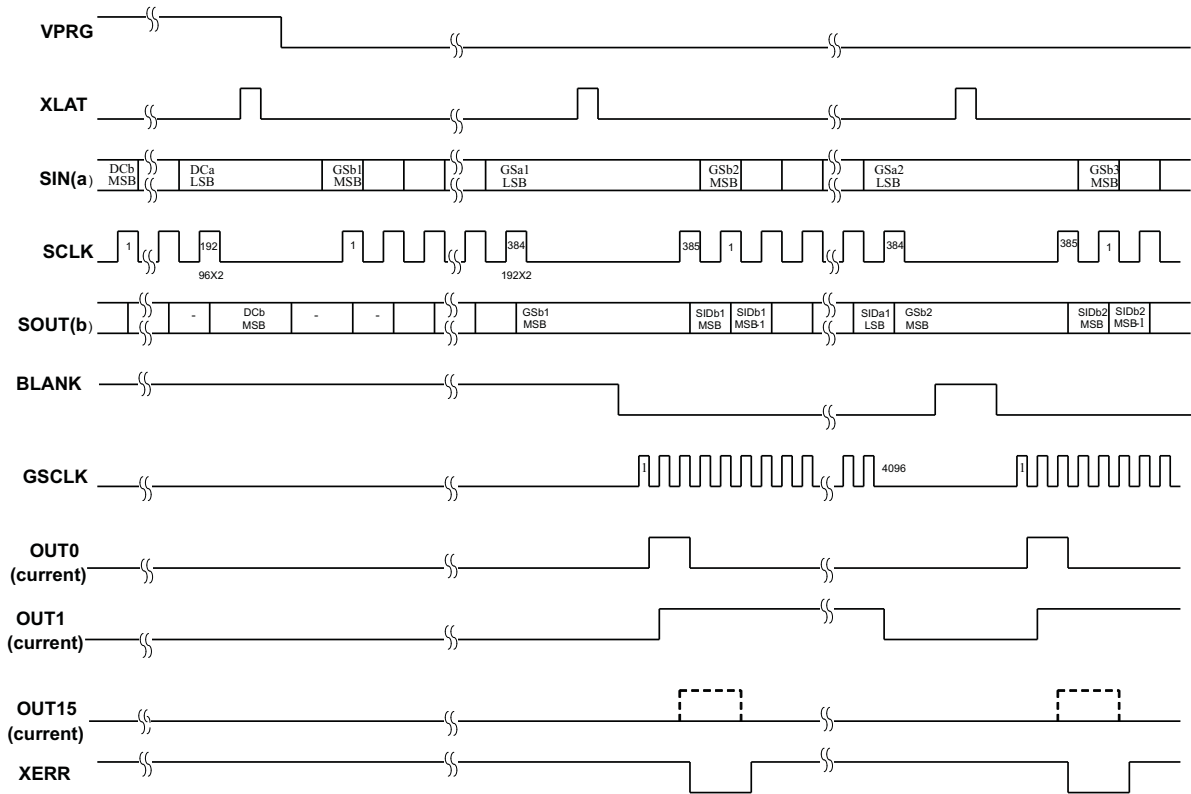

Figure 14. Timing Chart for Two Cascaded TLC5940-EP Devices

8.3.2 Error Information Output

The open-drain output XERR is used to report both of the TLC5940-EP error flags, TEF and LOD. During normal operating conditions, the internal transistor connected to the XERR pin is turned off. The voltage on XERR is pulled up to  $V_{CC}$  through an external pullup resistor. If TEF or LOD is detected, the internal transistor is turned on, and XERR is pulled to GND. Since XERR is an open-drain output, multiple ICs can be OR'ed together and pulled up to  $V_{CC}$  with a single pullup resistor. This reduces the number of signals needed to report a system error (see Figure 23).

To differentiate LOD and TEF signal from XERR pin, LOD can be masked out with BLANK = HIGH.

Table 1. XERR Truth Table

ERROR CONDITION		ERROR INFORMATION		SIGNALS	
TEMPERATURE	OUTn VOLTAGE	TEF	LOD	BLANK	XERR
$T_J < T_{(TEF)}$	Don't Care	L	X	H	H
$T_J > T_{(TEF)}$	Don't Care	H	X		L
$T_J < T_{(TEF)}$	$OUTn > V_{(LED)}$	L	L	L	H
	$OUTn < V_{(LED)}$	L	H		L
$T_J > T_{(TEF)}$	$OUTn > V_{(LED)}$	H	L		L
	$OUTn < V_{(LED)}$	H	H		L

### 8.3.3 TEF: Thermal Error Flag

The TLC5940-EP provides a temperature error flag (TEF) circuit to indicate an overtemperature condition of the IC. If the junction temperature exceeds the threshold temperature (160°C typical), TEF becomes H and XERR pin goes to low level. When the junction temperature becomes lower than the threshold temperature, TEF becomes L and XERR pin becomes high impedance. TEF status can also be read out from the TLC5940-EP status register.

### 8.3.4 LOD: LED Open Detection

The TLC5940-EP has an LED-open detector that detects broken or disconnected LEDs. The LED open detector pulls the XERR pin to GND when an open LED is detected. XERR and the corresponding error bit in the Status Information Data is only active under the following open-LED conditions.

1. OUT<sub>n</sub> is on and the time tpd2 (1 μs typical) has passed.
2. The voltage of OUT<sub>n</sub> is < 0.3 V (typical)

The LOD status of each output can be also read out from the SOUT pin. See [Status Information Output](#) for details. The LOD error bits are latched into the Status Information Data when XLAT returns to a low after a high. Therefore, the XLAT pin must be pulsed high then low while XERR is active in order to latch the LOD error into the Status Information Data for subsequent reading via the serial shift register.

### 8.3.5 Delay Between Outputs

The TLC5940-EP has graduated delay circuits between outputs. These circuits can be found in the constant current driver block of the device (see [Functional Block Diagram](#)). The fixed-delay time is 20 ns (typical), OUT0 has no delay, OUT1 has 20-ns delay, and OUT2 has 40-ns delay, and so forth. The maximum delay is 300 ns from OUT0 to OUT15. The delay works during switch on and switch off of each output channel. These delays prevent large inrush currents which reduces the bypass capacitors when the outputs turn on.

### 8.3.6 Output Enable

All OUT<sub>n</sub> channels of the TLC5940-EP can be switched off with one signal. When BLANK is set high, all OUT<sub>n</sub> channels are disabled, regardless of logic operations of the device. The grayscale counter is also reset. When BLANK is set low, all OUT<sub>n</sub> channels work under normal conditions. If BLANK goes low and then back high again in less than 300 ns, all outputs programmed to turn on still turn on for either the programmed number of grayscale clocks, or the length of time that the BLANK signal was low, which ever is lower. For example, if all outputs are programmed to turn on for 1 ms, but the BLANK signal is only low for 200 ns, all outputs still turn on for 200 ns, even though some outputs are turning on after the BLANK signal has already gone high.

**Table 2. BLANK Signal Truth Table**

BLANK	OUT0 - OUT15
LOW	Normal condition
HIGH	Disabled

### 8.3.7 Setting Maximum Channel Current

The maximum output current per channel is programmed by a single resistor, R<sub>(IREF)</sub>, which is placed between IREF pin and GND pin. The voltage on IREF is set by an internal band gap V<sub>(IREF)</sub> with a typical value of 1.24 V. The maximum channel current is equivalent to the current flowing through R<sub>(IREF)</sub> multiplied by a factor of 31.5. The maximum output current per channel can be calculated by [Equation 6](#):

$$I_{\max} = \frac{V_{(IREF)}}{R_{(IREF)}} \times 31.5$$

where

- V<sub>(IREF)</sub> = 1.24 V.
- R<sub>(IREF)</sub> = User-selected external resistor. (6)

I<sub>max</sub> must be set between 5 mA and 120 mA. The output current may be unstable if I<sub>max</sub> is set lower than 5 mA. Output currents lower than 5 mA can be achieved by setting I<sub>max</sub> to 5 mA or higher and then using dot correction.

Figure 1 shows the maximum output current  $I_O$  versus  $R_{(IREF)}$ .  $R_{(IREF)}$  is the value of the resistor between IREF terminal to GND, and  $I_O$  is the constant output current of OUT0 to OUT15. A variable power supply may be connected to the IREF pin through a resistor to change the maximum output current per channel. The maximum output current per channel is 31.5 times the current flowing out of the IREF pin.

### 8.4 Device Functional Modes

#### 8.4.1 Operating Modes

The TLC5940-EP has operating modes depending on the signals DCPRG and VPRG. Table 3 shows the available operating modes. The TPS5940 GS operating mode (see Figure 12) and shift register values are not defined after power up. One solution to solve this is to set dot correction data after TLC5940 power up and switch back to GS PWM mode. The other solution is to overflow the input shift register with 193 bits of dummy data and latch it while TLC540 is in GS PWM mode. The values in the input shift register, DC register and GS register are unknown just after power on. The DC and GS register values should be properly stored through the serial interface before starting the operation.

Table 3. TLC5940-EP Operating Modes Truth Table

SIGNAL		INPUT SHIFT REGISTER	MODE	DC VALUE
DCPRG	VPRG			
L	GND	192 bit	Grayscale PWM Mode	EEPROM
H				DC Register
L	V <sub>CC</sub>	96 bit	Dot Correction Data Input Mode	EEPROM
H				DC Register
L	V <sub>(VPRG)</sub>	X	EEPROM Programming Mode	EEPROM
H				Write DC register value to EEPROM. (Default data: 3Fh)

#### 8.4.2 Setting Dot Correction

The TLC5940-EP has the capability to fine adjust the output current of each channel OUT0 to OUT15 independently. This is also called dot correction. This feature is used to adjust the brightness deviations of LEDs connected to the output channels OUT0 to OUT15. Each of the 16 channels can be programmed with a 6-bit word. The channel output can be adjusted in 64 steps from 0% to 100% of the maximum output current  $I_{max}$ . Dot correction for all channels must be entered at the same time. Equation 7 determines the output current for each output n:

$$I_{OUTn} = I_{max} \times \frac{DCn}{63}$$

where

- $I_{max}$  = the maximum programmable output current for each output.
- DCn = the programmed dot correction value for output n (DCn = 0 to 63).
- n = 0 to 15

(7)

Figure 15 shows the dot correction data packet format which consists of 6 bits × 16 channel, total 96 bits. The format is Big-Endian format. This means that the MSB is transmitted first, followed by the MSB-1, and so forth. The DC 15.5 in Figure 15 stands for the 5<sup>th</sup> most significant bit for output 15.



Figure 15. Dot Correction Data Packet Format

When VPRG is set to VCC, the TLC5940-EP enters the dot correction data input mode. The length of input shift register becomes 96 bits. After all serial data are shifted in, the TLC5940-EP writes the data in the input shift register to DC register when XLAT is high, and holds the data in the DC register when XLAT is low. The DC register is a level triggered latch of XLAT signal. Since XLAT is a level-triggered signal, SCLK and SIN must not be changed while XLAT is high. After XLAT goes low, data in the DC register is latched and does not change. BLANK signal does not need to be high to latch in new data. XLAT has setup time ( $t_{su1}$ ) and hold time ( $t_{h1}$ ) to SCLK as shown in Figure 16.

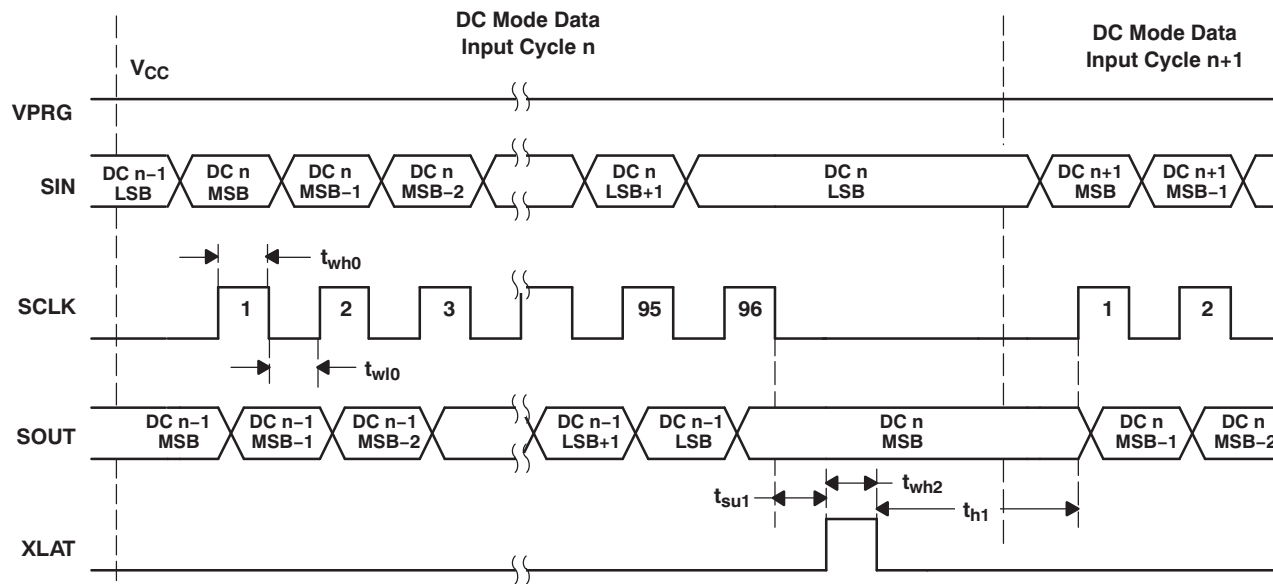

Figure 16. Dot Correction Data Input Timing Chart

The TLC5940-EP also has an EEPROM to store dot correction data. To store data from the dot correction register to EEPROM, DCPRG is set to high after applying  $V_{PRG}$  to the VPRG pin. Figure 17 shows the EEPROM programming timings. The EEPROM has a default value of all 1s.

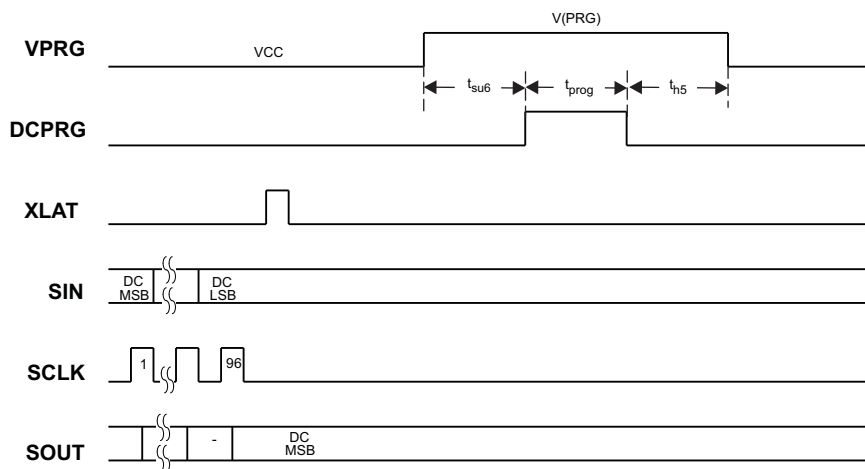

Figure 17. EEPROM Programming Timing Chart

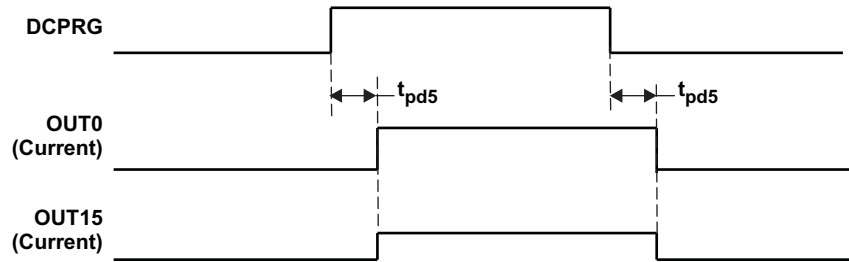

Figure 18. DCPRG and OUTn Timing Diagram

### 8.4.3 Setting Grayscale

The TLC5940-EP can adjust the brightness of each channel OUTn using a PWM control scheme. The use of 12 bits per channel results in 4096 different brightness steps, respective 0% to 100% brightness. Equation 8 determines the brightness level for each output n:

$$\text{Brightness in \%} = \frac{\text{GS}_n}{4095} \times 100$$

where

- GS<sub>n</sub> = the programmed grayscale value for output n (GS<sub>n</sub> = 0 to 4095)
- n = 0 to 15
- Grayscale data for all OUTn

(8)

Figure 19 shows the grayscale data packet format which consists of 12 bits × 16 channels, totaling 192 bits. The format is Big-Endian format. This means that the MSB is transmitted first, followed by the MSB-1, and so forth.



Figure 19. Grayscale Data Packet Format

When VPRG is set to GND, the TLC5940-EP enters the grayscale data input mode. The device switches the input shift register to 192-bit width. After all data is clocked in, a rising edge of the XLAT signal latches the data into the grayscale register (see Figure 12). New grayscale data immediately becomes valid at the rising edge of the XLAT signal; therefore, new grayscale data should be latched at the end of a grayscale cycle when BLANK is high. The first GS data input cycle after dot correction requires an additional SCLK pulse after the XLAT signal to complete the grayscale update cycle. All GS data in the input shift register is replaced with status information data (SID) after updated the grayscale register.

### 8.4.4 Status Information Output

The TLC5940-EP does have a status information register, which can be accessed in grayscale mode (VPRG=GND). After the XLAT signal latches the data into the GS register the input shift register data will be replaced with status information data (SID) of the device (see Figure 19). LOD, TEF, and dot correction EEPROM data (DCPRG=LOW) or dot correction register data (DCPRG=HIGH) can be read out at SOUT pin. The status information data packet is 192 bits wide. Bits 0-15 contain the LOD status of each channel. Bit 16 contains the TEF status. If DCPRG is low, bits 24-119 contain the data of the dot-correction EEPROM. If DCPRG is high, bits 24-119 contain the data of the dot-correction register. The remaining bits are reserved. The complete status information data packet is shown in Figure 20.

SOUT outputs the MSB of the SID at the same time the SID are stored in the SID register, as shown Figure 21. The next SCLK pulse, which will be the clock for receiving the SMB of the next grayscale data, transmits MSB-1 of SID. If output voltage is < 0.3 V (typical) when the output sink current turns on, LOD status flag becomes active. The LOD status flag is an internal signal that pulls XERR pin down to low when the LOD status flag becomes active. The delay time, tpd2 (1 μs maximum), is from the time of turning on the output sink current to

the time LOD status flag becomes valid. The timing for each channel's LOD status to become valid is shifted by the 30-ns (maximum) channel-to-channel turnon time. After the first GSCLK goes high, OUT0 LOD status is valid;  $t_{pd3} + t_{pd2} = 60 \text{ ns} + 1 \mu\text{s}$ . OUT1 LOD status is valid;  $t_{pd3} + t_d + t_{pd2} = 60 \text{ ns} + 30 \text{ ns} + 1 \mu\text{s} = 1.09 \mu\text{s}$ . OUT2 LOD status is valid;  $t_{pd3} + 2 \cdot t_d + t_{pd2} = 1.12 \mu\text{s}$ , and so on. It takes  $1.51 \mu\text{s}$  maximum ( $t_{pd3} + 15 \cdot t_d + t_{pd2}$ ) from the first GSCLK rising edge until all LOD become valid;  $t_{suLOD}$  must be  $> 1.51 \mu\text{s}$  (see Figure 21) to ensure that all LOD data are valid.

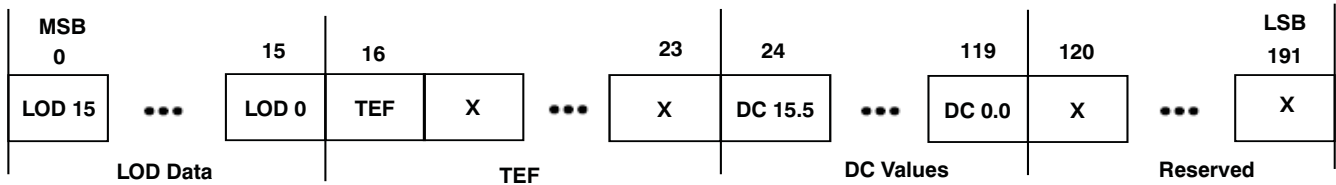

Figure 20. Status Information Data Packet Format

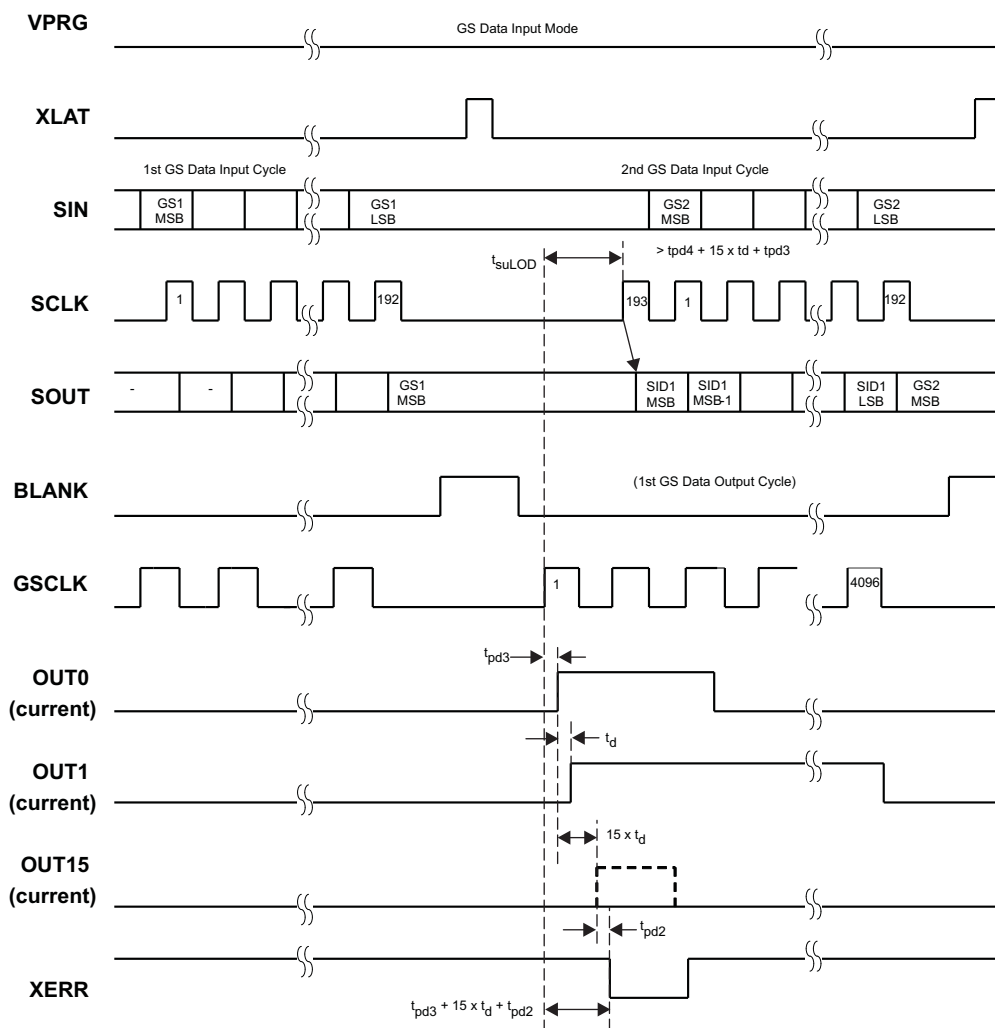
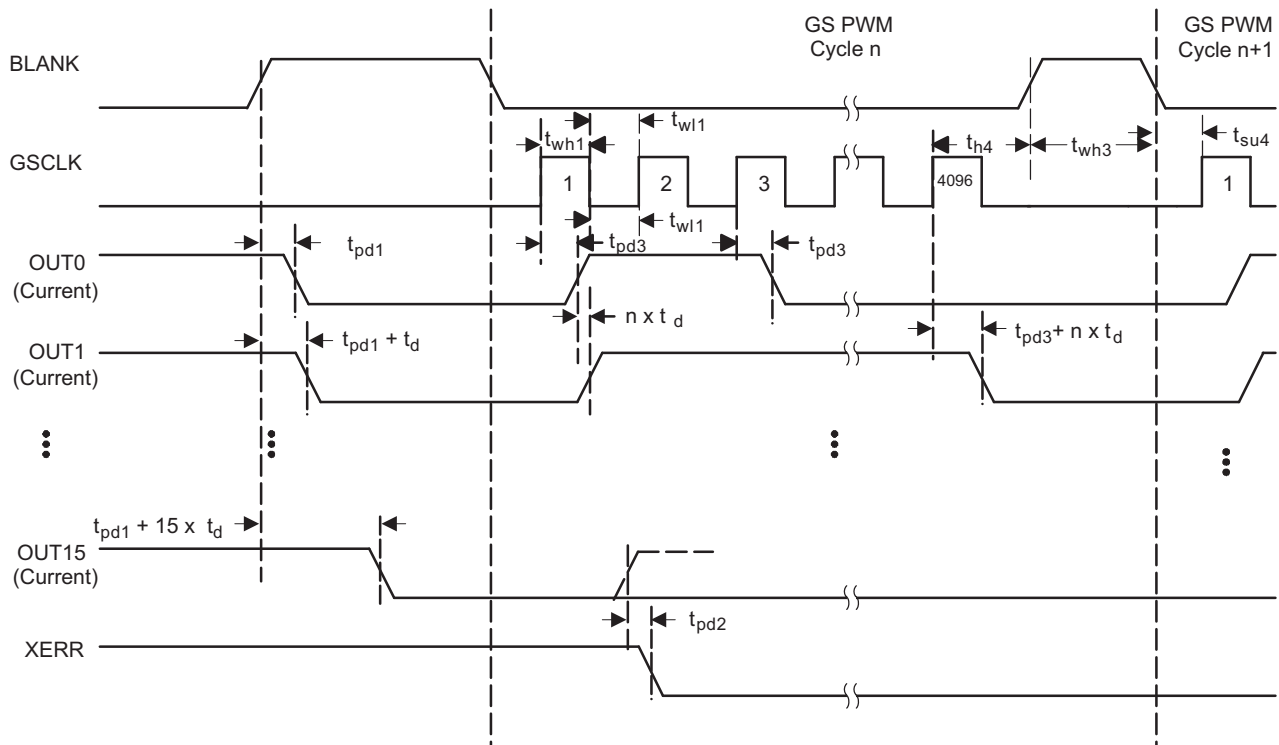

Figure 21. Readout Status Information Data (SID) Timing Chart

### 8.4.5 Grayscale PWM Operation

The grayscale PWM cycle starts with the falling edge of BLANK. The first GSCLK pulse after BLANK goes low increases the grayscale counter by one and switches on all OUT<sub>n</sub> with grayscale value not zero. Each following rising edge of GSCLK increases the grayscale counter by one. The TLC5940-EP compares the grayscale value of each output OUT<sub>n</sub> with the grayscale counter value. All OUT<sub>n</sub> with grayscale values equal to the counter values are switched off. A BLANK=H signal after 4096 GSCLK pulses resets the grayscale counter to zero and completes the grayscale PWM cycle (see Figure 22). When the counter reaches a count of FFFh, the counter stops counting and all outputs turn off. Pulling BLANK high before the counter reaches FFFh immediately resets the counter to zero.



**Figure 22. Grayscale PWM Cycle Timing Chart**

## 9 Application and Implementation

### NOTE

Information in the following applications sections is not part of the TI component specification, and TI does not warrant its accuracy or completeness. TI's customers are responsible for determining suitability of components for their purposes. Customers should validate and test their design implementation to confirm system functionality.

### 9.1 Application Information

The device is a 16-channel, constant sink current, LED driver. This device can be connected in series to drive many LED lamps with only a few controller ports. Output current control data, dot correction data and PWM control data can be written from the SIN input terminal.

### 9.2 Typical Application

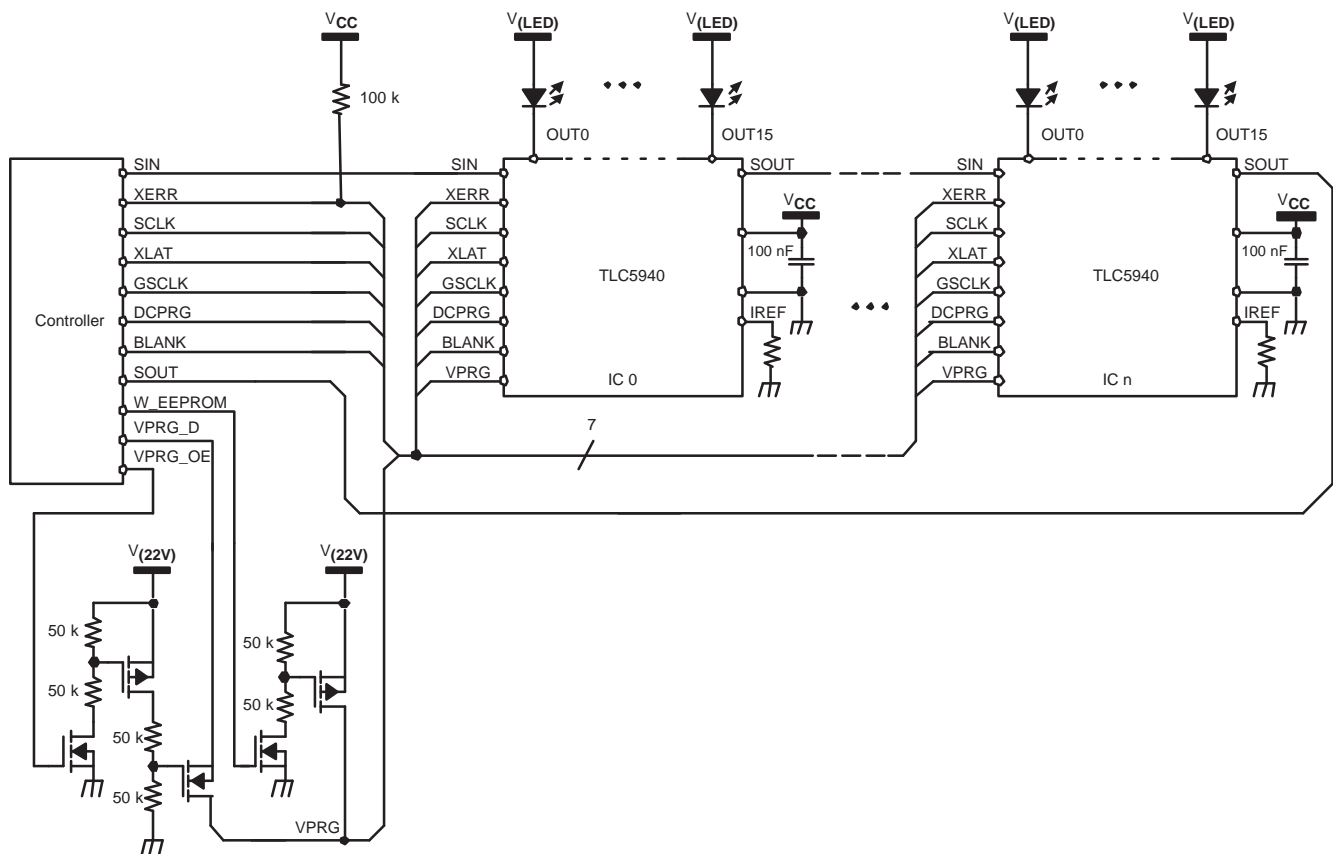

Figure 23. Cascading Devices

#### 9.2.1 Design Requirements

For this design example, use the input parameters shown in Table 4.

Table 4. Design Parameters

PARAMETERS	VALUES
VCC input voltage range	3 V to 5.5 V
LED lamp ( $V_{LED}$ ) input voltage range	>Maximum LED forward voltage ( $V_F$ ) + IC knee voltage
SIN, SCLK, XLAT, GSCLK, and BLANK voltage range	Low level = GND, High level = VCC

## 9.2.2 Detailed Design Procedures

### 9.2.2.1 Serial Data Transfer Rate

Figure 23 shows a cascading connection of  $n$  TLC5940-EP devices connected to a controller, building a basic module of an LED display system. The maximum number of cascading TLC5940-EP devices depends on the application system and is in the range of 40 devices. Equation 9 calculates the minimum frequency needed:

$$f_{(\text{GSCLK})} = 4096 \times f_{(\text{update})}$$

$$f_{(\text{SCLK})} = 193 \times f_{(\text{update})} \times n$$

where

- $f_{(\text{GSCLK})}$ : minimum frequency needed for GSCLK
- $f_{(\text{SCLK})}$ : minimum frequency needed for SCLK and SIN
- $f_{(\text{update})}$ : update rate of whole cascading system
- $n$ : number cascaded of TLC5940-EP device

(9)

### 9.2.2.2 Grayscale (GS) Data

There are a total of 16 sets of 12-bit GS data for the PWM control of each output. Select the GS data of each LED lamp and write the GS data to the register following the signal timing.

### 9.2.3 Application Curve

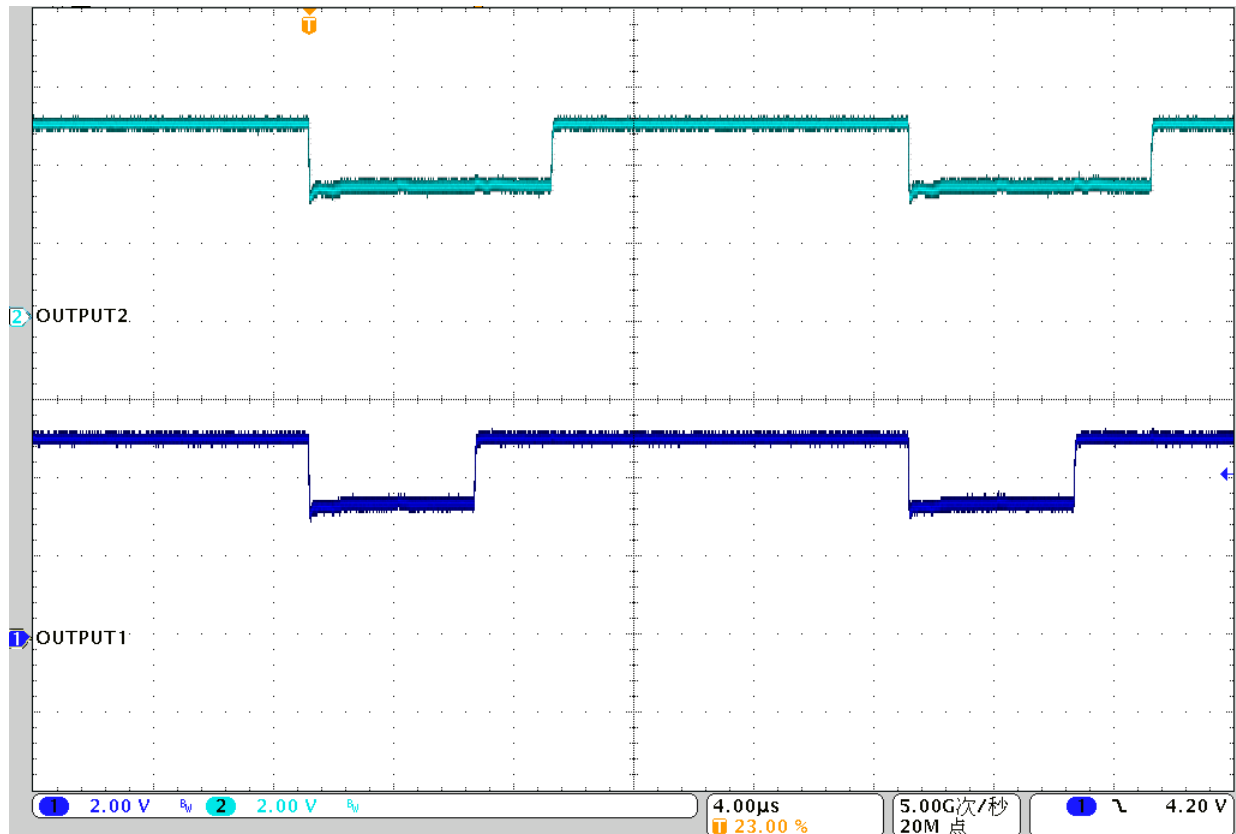

Figure 24. Output Waveform with Different Grayscale PWM Data

## 10 Power Supply Recommendations

The  $V_{CC}$  power supply voltage should be decoupled by placing a 0.1- $\mu\text{F}$  ceramic capacitor close to VCC pin and GND plane. Depending on panel size, several electrolytic capacitors must be placed on board equally distributed to get a well-regulated LED supply voltage (VLED). VLED voltage ripple should be less than 5% of its nominal value. Furthermore, the VLED should be set to the voltage calculated by Equation 10:

$$V_{LED} > V_F + 0.4 \text{ V ( 10-mA constant current example)}$$

where

- $V_f$  = maximum forward voltage of all LEDs (10)

## 11 Layout

### 11.1 Layout Guidelines

1. Place the decoupling capacitor near the VCC pin and GND plane.
2. Place the current programming resistor Riref close to IREF pin and IREFGND pin.
3. Route the GND pattern as widely as possible for large GND currents.
4. Routing wire between the LED cathode side and the device OUTn pin should be as short and straight as possible to reduce wire inductance.
5. When several ICs are chained, symmetric placements are recommended.

### 11.2 Layout Example

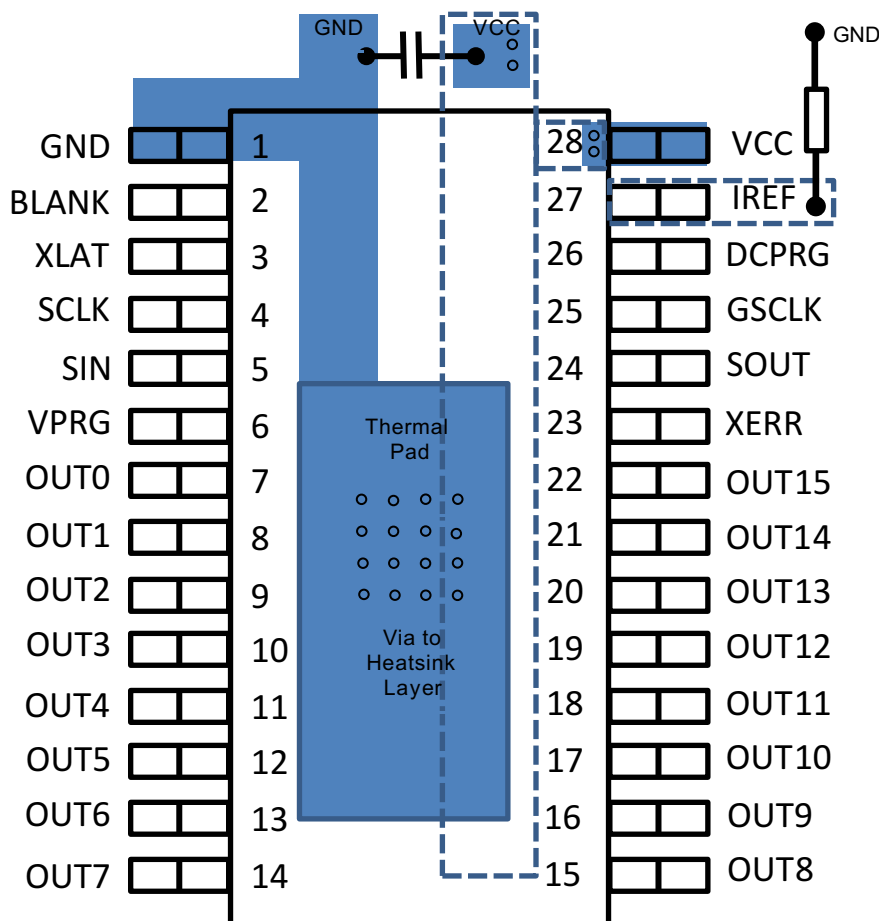

Figure 25. Layout Recommendation

### 11.3 Power Dissipation Calculation

The device power dissipation must be below the power dissipation rating of the device package to ensure correct operation. [Equation 11](#) calculates the power dissipation of device:

$$P_D = (V_{CC} \times I_{CC}) + (V_{OUT} \times I_{MAX} \times \frac{DC_n}{63} \times d_{PWM} \times N)$$

where

- $V_{CC}$ : device supply voltage
- $I_{CC}$ : device supply current
- $V_{OUT}$ : TLC5940-EP OUTn voltage when driving LED current
- $I_{MAX}$ : LED current adjusted by  $R_{(REF)}$  Resistor
- $DC_n$ : maximum dot correction value for OUTn
- $N$ : number of OUTn driving LED at the same time
- $d_{PWM}$ : duty cycle defined by BLANK pin or GS PWM value

(11)

## 12 Device and Documentation Support

### 12.1 Receiving Notification of Documentation Updates

To receive notification of documentation updates, navigate to the device product folder on ti.com. In the upper right corner, click on *Alert me* to register and receive a weekly digest of any product information that has changed. For change details, review the revision history included in any revised document.

### 12.2 Community Resources

The following links connect to TI community resources. Linked contents are provided "AS IS" by the respective contributors. They do not constitute TI specifications and do not necessarily reflect TI's views; see TI's [Terms of Use](#).

**TI E2E™ Online Community** *TI's Engineer-to-Engineer (E2E) Community*. Created to foster collaboration among engineers. At e2e.ti.com, you can ask questions, share knowledge, explore ideas and help solve problems with fellow engineers.

**Design Support** *TI's Design Support* Quickly find helpful E2E forums along with design support tools and contact information for technical support.

### 12.3 Trademarks

E2E is a trademark of Texas Instruments.  
All other trademarks are the property of their respective owners.

### 12.4 Electrostatic Discharge Caution



These devices have limited built-in ESD protection. The leads should be shorted together or the device placed in conductive foam during storage or handling to prevent electrostatic damage to the MOS gates.

### 12.5 Glossary

[SLYZ022](#) — *TI Glossary*.

This glossary lists and explains terms, acronyms, and definitions.

## 13 Mechanical, Packaging, and Orderable Information

The following pages include mechanical, packaging, and orderable information. This information is the most current data available for the designated devices. This data is subject to change without notice and revision of this document. For browser-based versions of this data sheet, refer to the left-hand navigation.

**PACKAGING INFORMATION**

Orderable Device	Status (1)	Package Type	Package Drawing	Pins	Package Qty	Eco Plan (2)	Lead/Ball Finish (6)	MSL Peak Temp (3)	Op Temp (°C)	Device Marking (4/5)	Samples
TLC5940QPWPREP	ACTIVE	HTSSOP	PWP	28	2000	Green (RoHS & no Sb/Br)	CU NIPDAU	Level-2-260C-1 YEAR	-40 to 125	TLC5940EP	<a href="#">Samples</a>
TLC5940QRHBREP	ACTIVE	VQFN	RHB	32	3000	Green (RoHS & no Sb/Br)	CU NIPDAU	Level-2-260C-1 YEAR	-40 to 125	TLC 5940EP	<a href="#">Samples</a>
V62/10610-01XE	ACTIVE	HTSSOP	PWP	28	2000	Green (RoHS & no Sb/Br)	CU NIPDAU	Level-2-260C-1 YEAR	-40 to 125	TLC5940EP	<a href="#">Samples</a>
V62/10610-01YE	ACTIVE	VQFN	RHB	32	3000	Green (RoHS & no Sb/Br)	CU NIPDAU	Level-2-260C-1 YEAR	-40 to 125	TLC 5940EP	<a href="#">Samples</a>

(1) The marketing status values are defined as follows:

**ACTIVE:** Product device recommended for new designs.

**LIFEBUY:** TI has announced that the device will be discontinued, and a lifetime-buy period is in effect.

**NRND:** Not recommended for new designs. Device is in production to support existing customers, but TI does not recommend using this part in a new design.

**PREVIEW:** Device has been announced but is not in production. Samples may or may not be available.

**OBSELETE:** TI has discontinued the production of the device.

(2) Eco Plan - The planned eco-friendly classification: Pb-Free (RoHS), Pb-Free (RoHS Exempt), or Green (RoHS & no Sb/Br) - please check <http://www.ti.com/productcontent> for the latest availability information and additional product content details.

**TBD:** The Pb-Free/Green conversion plan has not been defined.

**Pb-Free (RoHS):** TI's terms "Lead-Free" or "Pb-Free" mean semiconductor products that are compatible with the current RoHS requirements for all 6 substances, including the requirement that lead not exceed 0.1% by weight in homogeneous materials. Where designed to be soldered at high temperatures, TI Pb-Free products are suitable for use in specified lead-free processes.

**Pb-Free (RoHS Exempt):** This component has a RoHS exemption for either 1) lead-based flip-chip solder bumps used between the die and package, or 2) lead-based die adhesive used between the die and leadframe. The component is otherwise considered Pb-Free (RoHS compatible) as defined above.

**Green (RoHS & no Sb/Br):** TI defines "Green" to mean Pb-Free (RoHS compatible), and free of Bromine (Br) and Antimony (Sb) based flame retardants (Br or Sb do not exceed 0.1% by weight in homogeneous material)

(3) MSL, Peak Temp. - The Moisture Sensitivity Level rating according to the JEDEC industry standard classifications, and peak solder temperature.

(4) There may be additional marking, which relates to the logo, the lot trace code information, or the environmental category on the device.

(5) Multiple Device Markings will be inside parentheses. Only one Device Marking contained in parentheses and separated by a "~" will appear on a device. If a line is indented then it is a continuation of the previous line and the two combined represent the entire Device Marking for that device.

(6) Lead/Ball Finish - Orderable Devices may have multiple material finish options. Finish options are separated by a vertical ruled line. Lead/Ball Finish values may wrap to two lines if the finish value exceeds the maximum column width.

**Important Information and Disclaimer:** The information provided on this page represents TI's knowledge and belief as of the date that it is provided. TI bases its knowledge and belief on information provided by third parties, and makes no representation or warranty as to the accuracy of such information. Efforts are underway to better integrate information from third parties. TI has taken and continues to take reasonable steps to provide representative and accurate information but may not have conducted destructive testing or chemical analysis on incoming materials and chemicals. TI and TI suppliers consider certain information to be proprietary, and thus CAS numbers and other limited information may not be available for release.

In no event shall TI's liability arising out of such information exceed the total purchase price of the TI part(s) at issue in this document sold by TI to Customer on an annual basis.

**OTHER QUALIFIED VERSIONS OF TLC5940-EP :**

- Catalog: [TLC5940](#)

NOTE: Qualified Version Definitions:

- Catalog - TI's standard catalog product

**TAPE AND REEL INFORMATION**

**QUADRANT ASSIGNMENTS FOR PIN 1 ORIENTATION IN TAPE**

\*All dimensions are nominal

Device	Package Type	Package Drawing	Pins	SPQ	Reel Diameter (mm)	Reel Width W1 (mm)	A0 (mm)	B0 (mm)	K0 (mm)	P1 (mm)	W (mm)	Pin1 Quadrant
TLC5940QPWPREP	HTSSOP	PWP	28	2000	330.0	16.4	6.9	10.2	1.8	12.0	16.0	Q1
TLC5940QRHBREP	VQFN	RHB	32	3000	330.0	12.4	5.3	5.3	1.5	8.0	12.0	Q2

TAPE AND REEL BOX DIMENSIONS



\*All dimensions are nominal

Device	Package Type	Package Drawing	Pins	SPQ	Length (mm)	Width (mm)	Height (mm)
TLC5940QPWPREP	HTSSOP	PWP	28	2000	367.0	367.0	38.0
TLC5940QRHBREP	VQFN	RHB	32	3000	367.0	367.0	35.0

## GENERIC PACKAGE VIEW

**RHB 32**

**VQFN - 1 mm max height**

5 x 5, 0.5 mm pitch

PLASTIC QUAD FLATPACK - NO LEAD

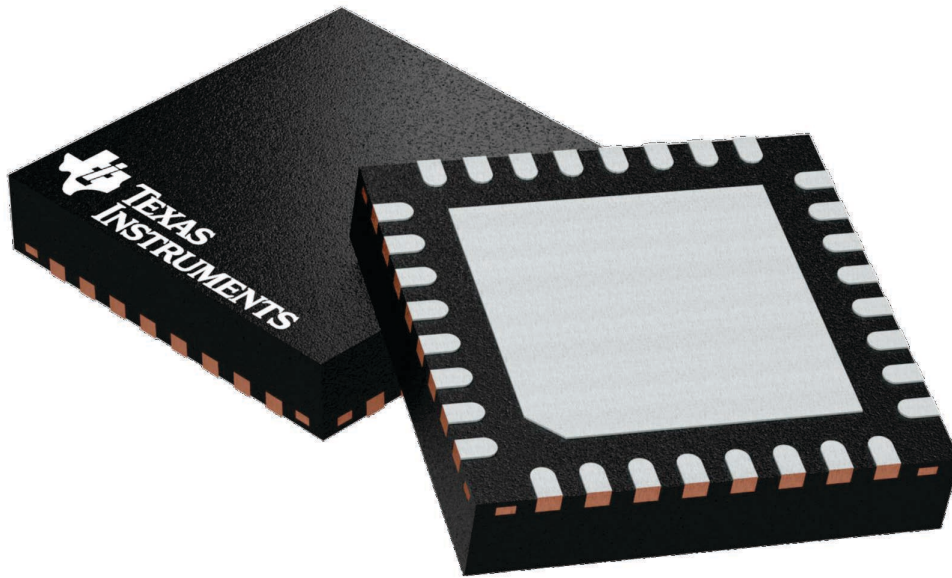

Images above are just a representation of the package family, actual package may vary.  
Refer to the product data sheet for package details.

4224745/A

RHB (S-PVQFN-N32)

PLASTIC QUAD FLATPACK NO-LEAD

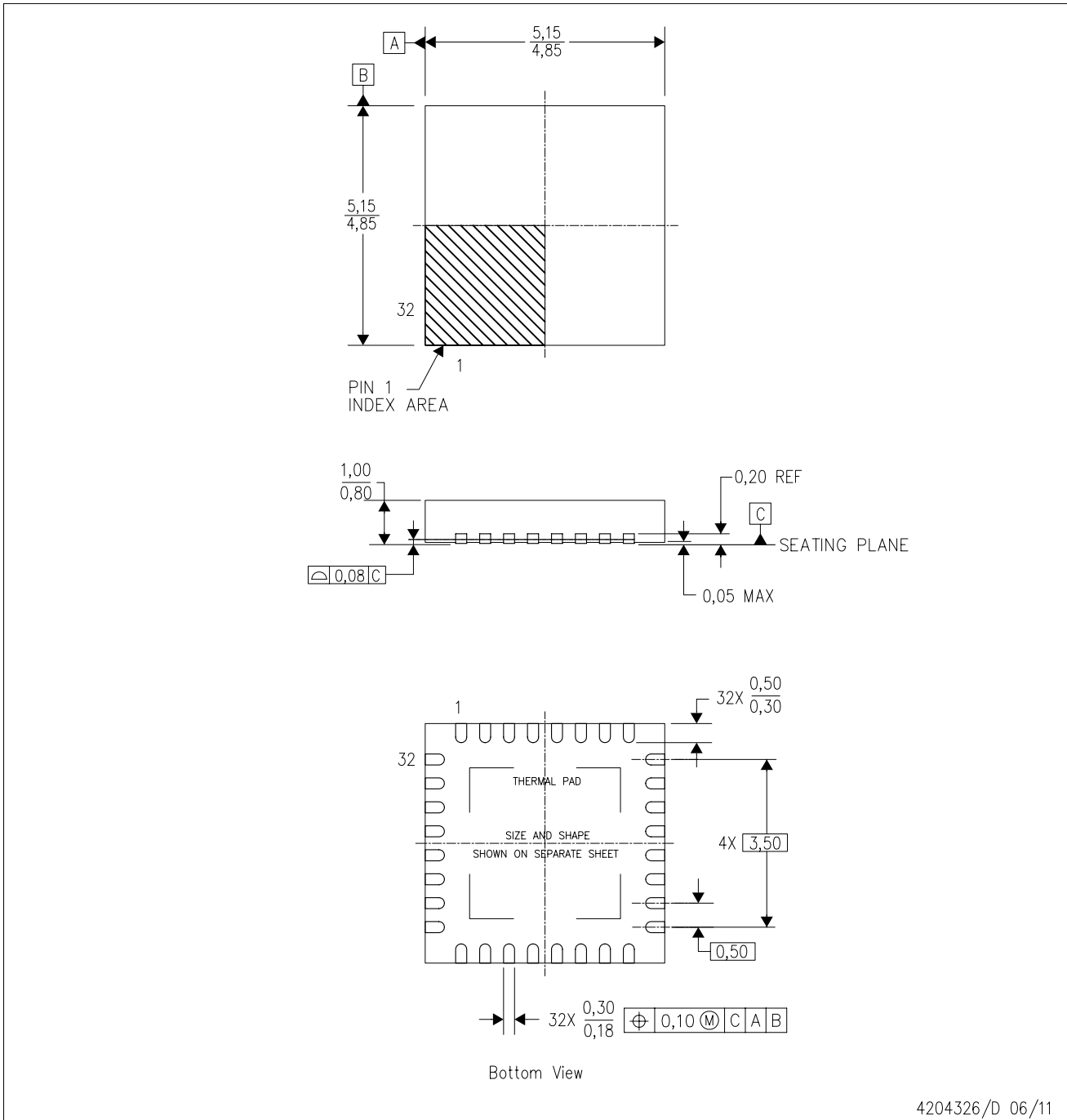

4204326/D 06/11

- NOTES:
- All linear dimensions are in millimeters. Dimensioning and tolerancing per ASME Y14.5M-1994.
  - This drawing is subject to change without notice.
  - QFN (Quad Flatpack No-Lead) Package configuration.
  - The package thermal pad must be soldered to the board for thermal and mechanical performance.
  - See the additional figure in the Product Data Sheet for details regarding the exposed thermal pad features and dimensions.
  - Falls within JEDEC MO-220.

## THERMAL INFORMATION

This package incorporates an exposed thermal pad that is designed to be attached directly to an external heatsink. The thermal pad must be soldered directly to the printed circuit board (PCB). After soldering, the PCB can be used as a heatsink. In addition, through the use of thermal vias, the thermal pad can be attached directly to the appropriate copper plane shown in the electrical schematic for the device, or alternatively, can be attached to a special heatsink structure designed into the PCB. This design optimizes the heat transfer from the integrated circuit (IC).

For information on the Quad Flatpack No-Lead (QFN) package and its advantages, refer to Application Report, QFN/SON PCB Attachment, Texas Instruments Literature No. SLUA271. This document is available at [www.ti.com](http://www.ti.com).

The exposed thermal pad dimensions for this package are shown in the following illustration.

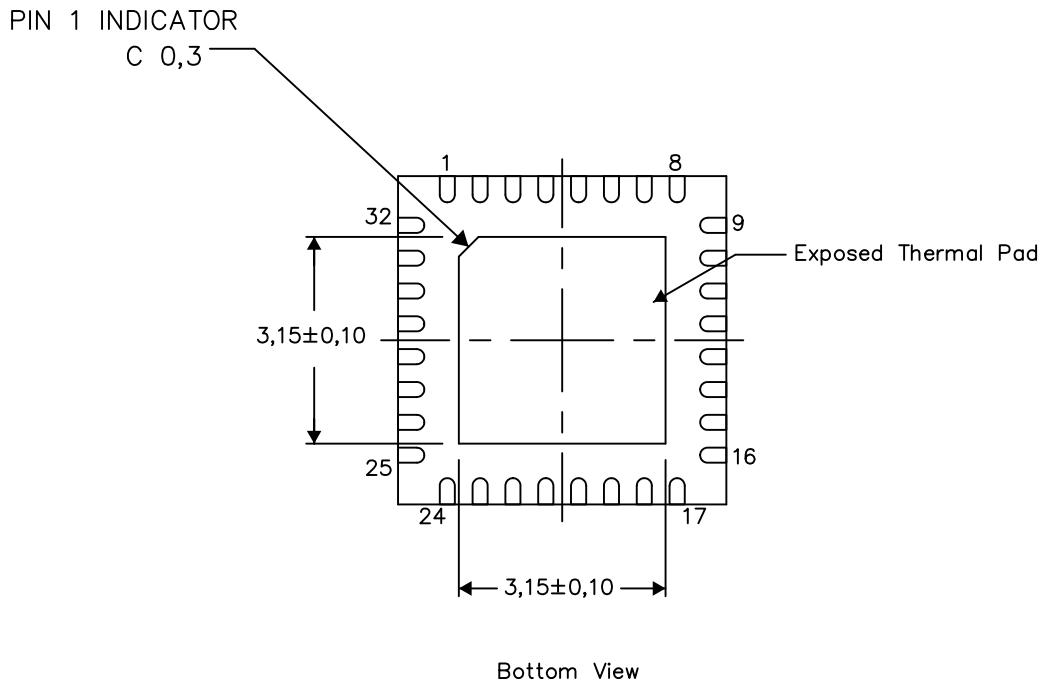

Exposed Thermal Pad Dimensions

4206356-3/AC 05/15

NOTE: A. All linear dimensions are in millimeters

RHB (S-PVQFN-N32)

PLASTIC QUAD FLATPACK NO-LEAD

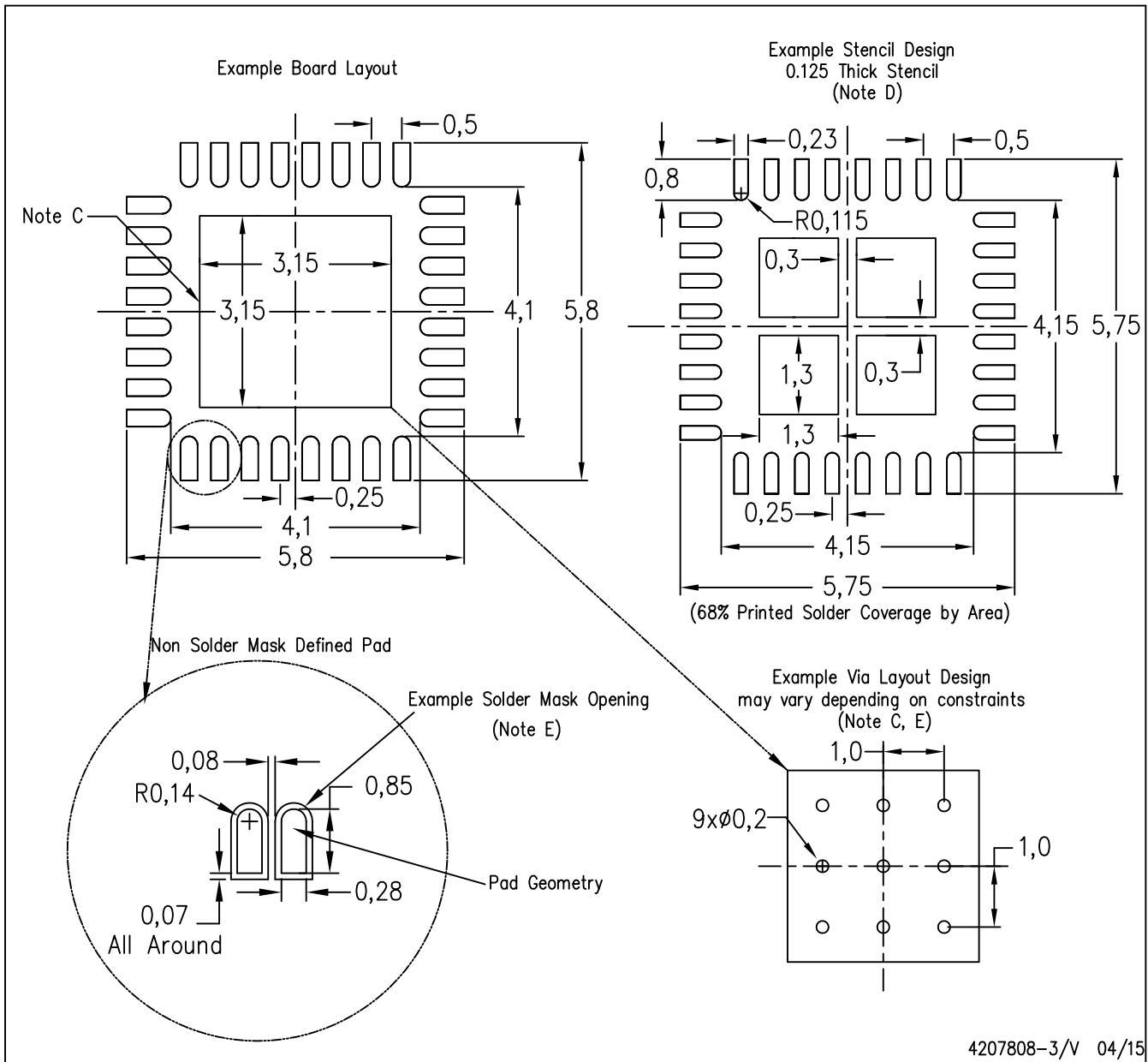

- NOTES:
- A. All linear dimensions are in millimeters.
  - B. This drawing is subject to change without notice.
  - C. This package is designed to be soldered to a thermal pad on the board. Refer to Application Note, Quad Flat-Pack Packages, Texas Instruments Literature No. SLUA271, and also the Product Data Sheets for specific thermal information, via requirements, and recommended board layout. These documents are available at [www.ti.com](http://www.ti.com) <<http://www.ti.com>>.
  - D. Laser cutting apertures with trapezoidal walls and also rounding corners will offer better paste release. Customers should contact their board assembly site for stencil design recommendations. Refer to IPC 7525 for stencil design considerations.
  - E. Customers should contact their board fabrication site for recommended solder mask tolerances and via tenting recommendations for any larger diameter vias placed in the thermal pad.

## GENERIC PACKAGE VIEW

**PWP 28**

**PowerPAD™ TSSOP - 1.2 mm max height**

4.4 x 9.7, 0.65 mm pitch

SMALL OUTLINE PACKAGE

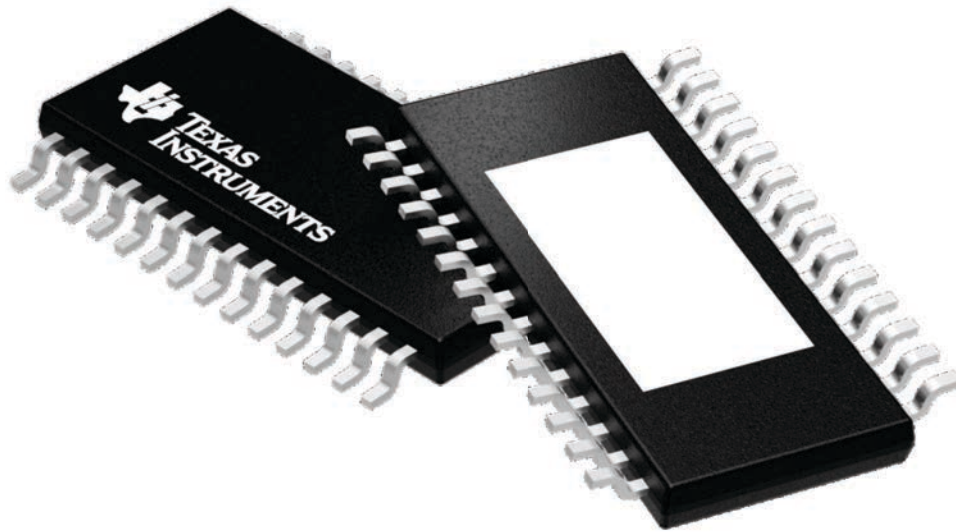

Images above are just a representation of the package family, actual package may vary.  
Refer to the product data sheet for package details.

4224765/A

# MECHANICAL DATA

PWP (R-PDSO-G28)

PowerPAD™ PLASTIC SMALL OUTLINE

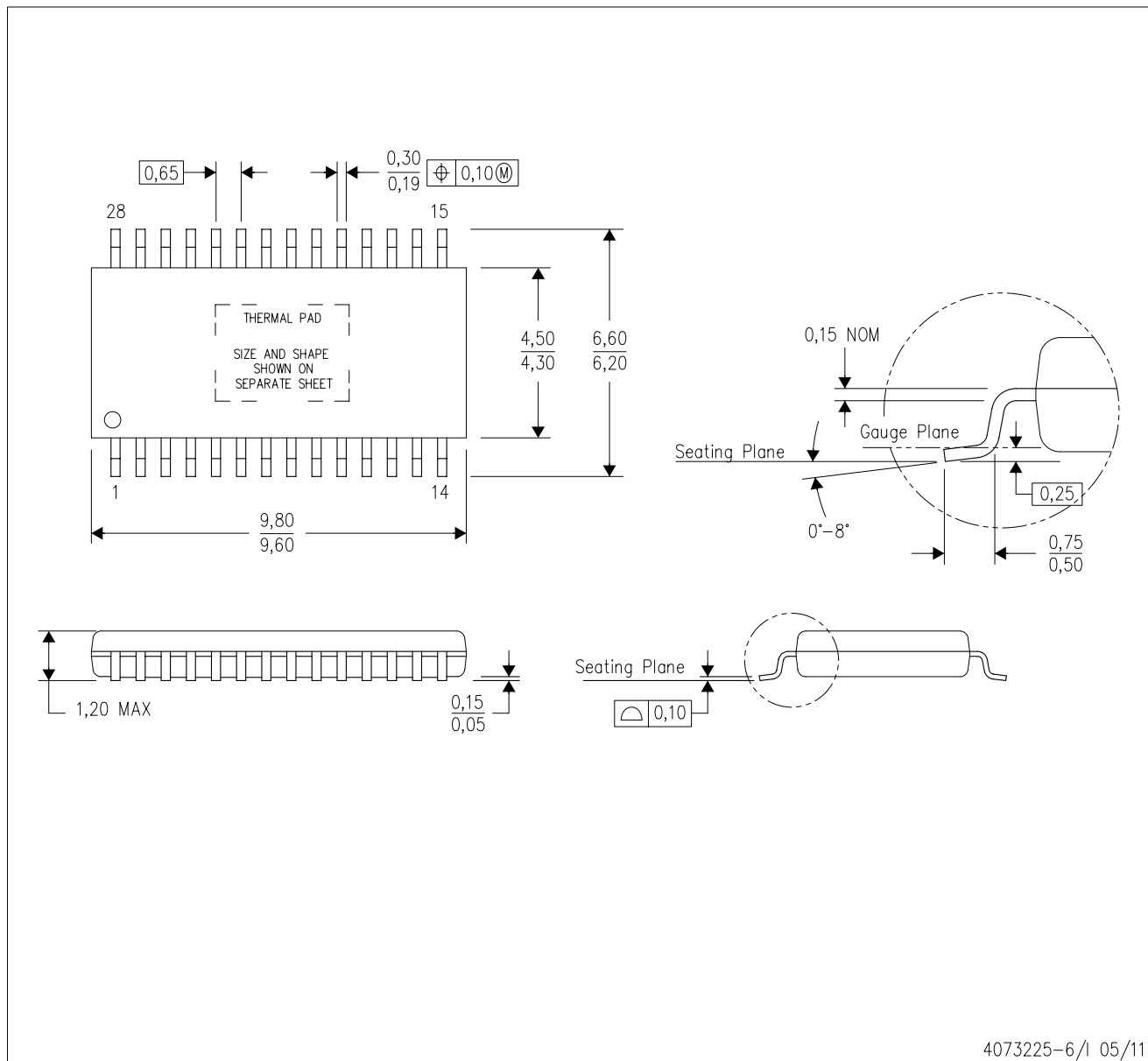

4073225-6/1 05/11

- NOTES:
- All linear dimensions are in millimeters.
  - This drawing is subject to change without notice.
  - Body dimensions do not include mold flash or protrusions. Mold flash and protrusion shall not exceed 0.15 per side.
  - This package is designed to be soldered to a thermal pad on the board. Refer to Technical Brief, PowerPad Thermally Enhanced Package, Texas Instruments Literature No. SLMA002 for information regarding recommended board layout. This document is available at [www.ti.com](http://www.ti.com) <<http://www.ti.com>>.
  - See the additional figure in the Product Data Sheet for details regarding the exposed thermal pad features and dimensions.
  - Falls within JEDEC MO-153

PowerPAD is a trademark of Texas Instruments.

# THERMAL PAD MECHANICAL DATA

## PWP (R-PDSO-G28) PowerPAD™ SMALL PLASTIC OUTLINE

### THERMAL INFORMATION

This PowerPAD™ package incorporates an exposed thermal pad that is designed to be attached to a printed circuit board (PCB). The thermal pad must be soldered directly to the PCB. After soldering, the PCB can be used as a heatsink. In addition, through the use of thermal vias, the thermal pad can be attached directly to the appropriate copper plane shown in the electrical schematic for the device, or alternatively, can be attached to a special heatsink structure designed into the PCB. This design optimizes the heat transfer from the integrated circuit (IC).

For additional information on the PowerPAD package and how to take advantage of its heat dissipating abilities, refer to Technical Brief, PowerPAD Thermally Enhanced Package, Texas Instruments Literature No. SLMA002 and Application Brief, PowerPAD Made Easy, Texas Instruments Literature No. SLMA004. Both documents are available at [www.ti.com](http://www.ti.com).

The exposed thermal pad dimensions for this package are shown in the following illustration.

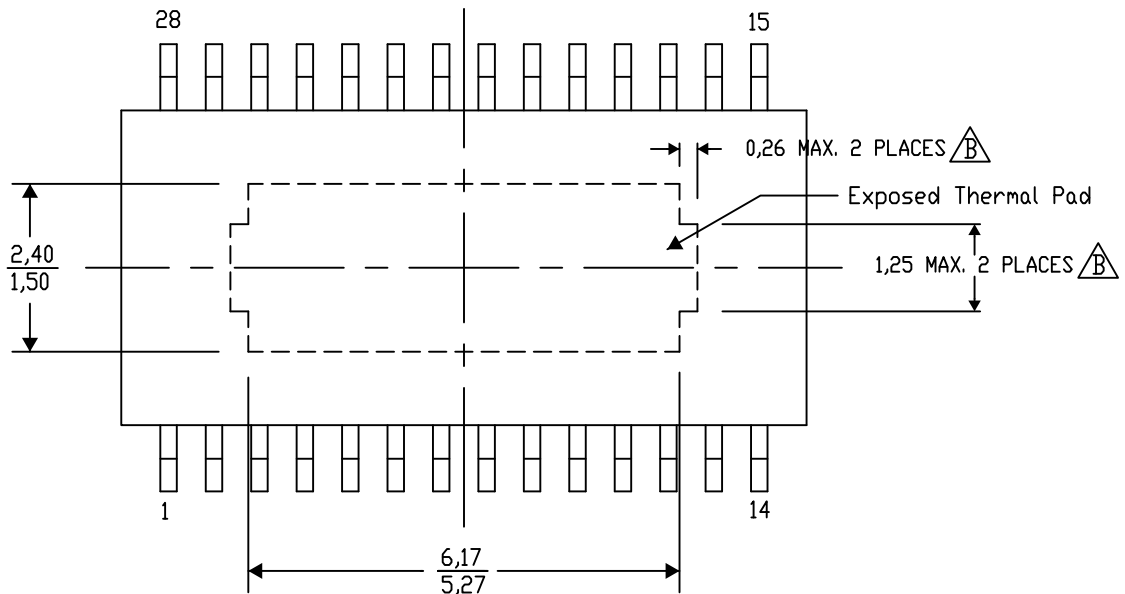

Exposed Thermal Pad Dimensions

4206332-33/AO 01/16

NOTE: A. All linear dimensions are in millimeters  
B. Exposed tie strap features may not be present.

PowerPAD is a trademark of Texas Instruments

PWP (R-PDSO-G28)

PowerPAD™ PLASTIC SMALL OUTLINE

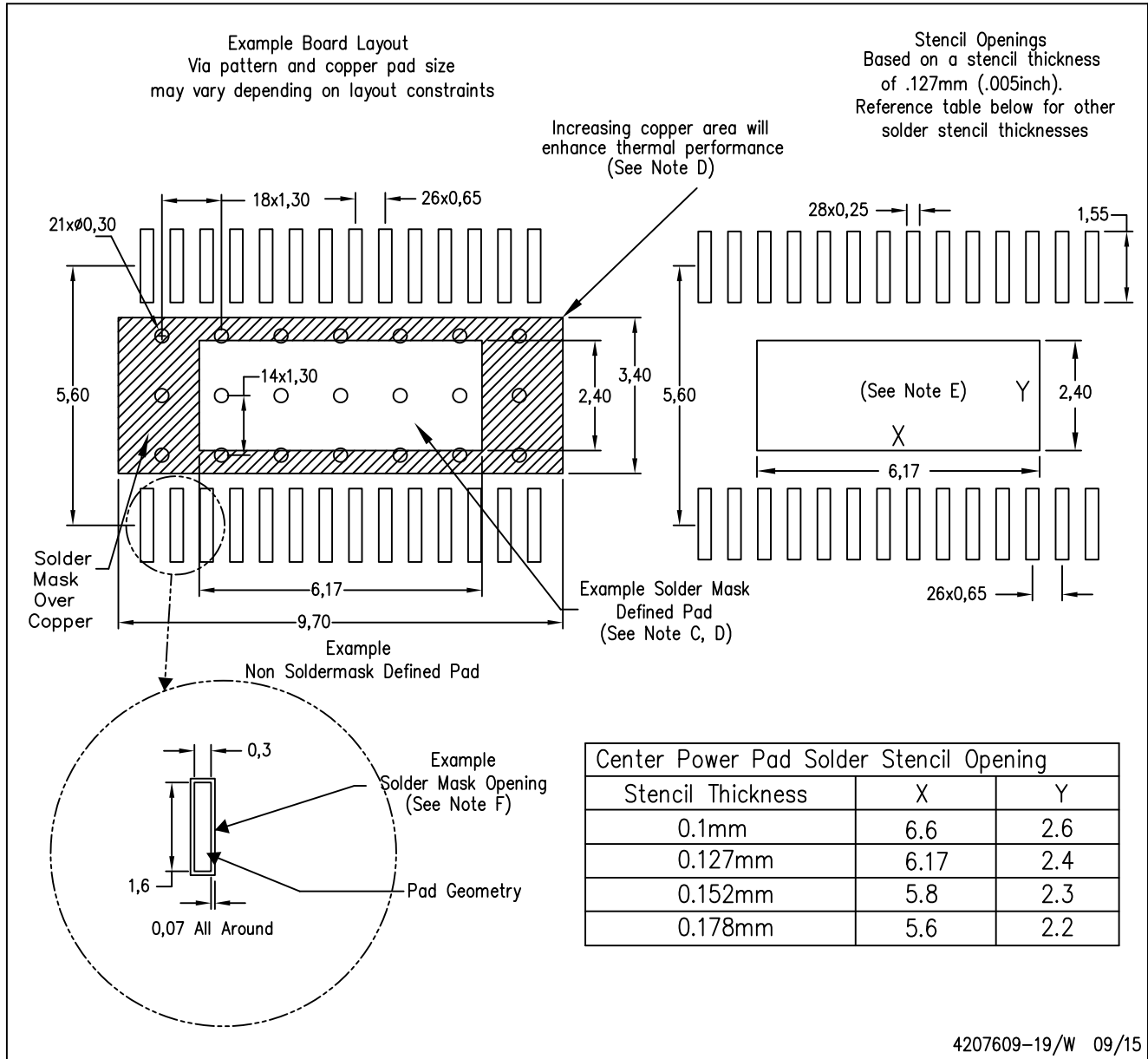

- NOTES:
- All linear dimensions are in millimeters.
  - This drawing is subject to change without notice.
  - Customers should place a note on the circuit board fabrication drawing not to alter the center solder mask defined pad.
  - This package is designed to be soldered to a thermal pad on the board. Refer to Technical Brief, PowerPad Thermally Enhanced Package, Texas Instruments Literature No. SLMA002, SLMA004, and also the Product Data Sheets.
  - For specific thermal information, via requirements, and recommended board layout. These documents are available at [www.ti.com](http://www.ti.com) <<http://www.ti.com>>. Publication IPC-7351 is recommended for alternate designs. Laser cutting apertures with trapezoidal walls and also rounding corners will offer better paste release. Customers should contact their board assembly site for stencil design recommendations. Example stencil design based on a 50% volumetric metal load solder paste. Refer to IPC-7525 for other stencil
  - Customers should contact their board fabrication site for solder mask tolerances between and around signal pads.

## IMPORTANT NOTICE AND DISCLAIMER

TI PROVIDES TECHNICAL AND RELIABILITY DATA (INCLUDING DATASHEETS), DESIGN RESOURCES (INCLUDING REFERENCE DESIGNS), APPLICATION OR OTHER DESIGN ADVICE, WEB TOOLS, SAFETY INFORMATION, AND OTHER RESOURCES "AS IS" AND WITH ALL FAULTS, AND DISCLAIMS ALL WARRANTIES, EXPRESS AND IMPLIED, INCLUDING WITHOUT LIMITATION ANY IMPLIED WARRANTIES OF MERCHANTABILITY, FITNESS FOR A PARTICULAR PURPOSE OR NON-INFRINGEMENT OF THIRD PARTY INTELLECTUAL PROPERTY RIGHTS.

These resources are intended for skilled developers designing with TI products. You are solely responsible for (1) selecting the appropriate TI products for your application, (2) designing, validating and testing your application, and (3) ensuring your application meets applicable standards, and any other safety, security, or other requirements. These resources are subject to change without notice. TI grants you permission to use these resources only for development of an application that uses the TI products described in the resource. Other reproduction and display of these resources is prohibited. No license is granted to any other TI intellectual property right or to any third party intellectual property right. TI disclaims responsibility for, and you will fully indemnify TI and its representatives against, any claims, damages, costs, losses, and liabilities arising out of your use of these resources.

TI's products are provided subject to TI's Terms of Sale ([www.ti.com/legal/termsofsale.html](http://www.ti.com/legal/termsofsale.html)) or other applicable terms available either on [ti.com](http://ti.com) or provided in conjunction with such TI products. TI's provision of these resources does not expand or otherwise alter TI's applicable warranties or warranty disclaimers for TI products.

Mailing Address: Texas Instruments, Post Office Box 655303, Dallas, Texas 75265  
Copyright © 2019, Texas Instruments Incorporated

## Looking for pricing, stock, or lifecycle information?

Click below to explore more details on WIN SOURCE:

 [View TLC5940QPWPREP on WIN SOURCE](#)

 [Texas Instruments](#) Information

## Optimize Your Supply Chain with WIN SOURCE Solutions

-  Global Sourcing Solution
-  Obsolete Management
-  Cost Control Management
-  Shortage Management
-  Alternative Solution
-  Excess Inventory Management