



**THE DATASHEET OF  
ADC08060CIMTX/NOPB**



# ADC08060 8-Bit, 20 MSPS to 60 MSPS, 1.3 m W/MSPS A/D Converter with Internal Sample-and-Hold

Check for Samples: [ADC08060](#)

## FEATURES

- Single-Ended Input
- Internal Sample-and-Hold Function
- Low Voltage (Single +3V) Operation
- Small Package
- Power-Down Feature

## KEY SPECIFICATION

- Resolution: 8 bits
- Maximum Sampling Frequency: 60 MSPS (min)
- DNL: 0.4 LSB(typ)
- ENOB 7.5bits (typ) at  $f_{IN} = 25$  MHz
- THD: -60 dB (typ)
- Power Consumption
  - Operating: 1.3 mW/MSPS (typ)
  - Power Down Mode: 1 mW (typ)

## APPLICATIONS

- Digital Imaging Systems
- Communication Systems
- Portable Instrumentation
- Viterbi Decoders
- Set-Top Boxes

## DESCRIPTION

The ADC08060 is a low-power, 8-bit, monolithic analog-to-digital converter with an on-chip track-and-hold circuit. Optimized for low cost, low power, small size and ease of use, this product operates at conversion rates of 20 MSPS to 70 MSPS with outstanding dynamic performance over its full operating range while consuming just 1.3 mW per MHz of clock frequency. That's just 78 mW of power at 60 MSPS. Raising the PD pin puts the ADC08060 into a Power Down mode where it consumes just 1 mW.

The unique architecture achieves 7.5 Effective Bits with 25 MHz input frequency. The excellent DC and AC characteristics of this device, together with its low power consumption and single +3V supply operation, make it ideally suited for many imaging and communications applications, including use in portable equipment. Furthermore, the ADC08060 is resistant to latch-up and the outputs are short-circuit proof. The top and bottom of the ADC08060's reference ladder are available for connections, enabling a wide range of input possibilities. The digital outputs are TTL/CMOS compatible with a separate output power supply pin to support interfacing with 3V or 2.5V logic. The output coding is straight binary and the digital inputs (CLK and PD) are TTL/CMOS compatible.

The ADC08060 is offered in a 24-lead TSSOP package and is specified over the industrial temperature range of -40°C to +85°C.



Please be aware that an important notice concerning availability, standard warranty, and use in critical applications of Texas Instruments semiconductor products and disclaimers thereto appears at the end of this data sheet.

All trademarks are the property of their respective owners.

**Block Diagram**

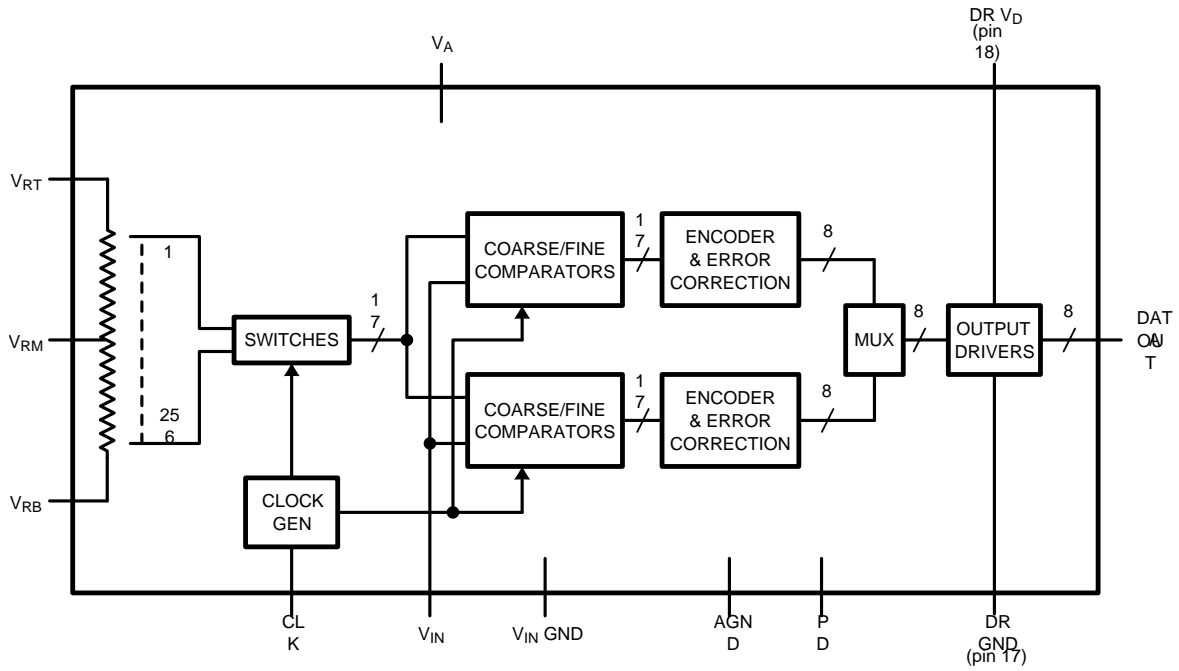

**Pin Configuration**

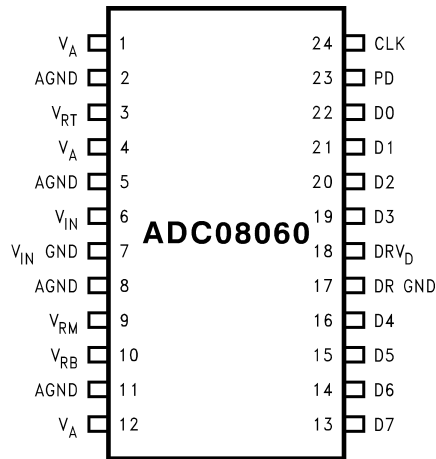

**Figure 1. 24-Lead TSSOP  
See PW Package**

PIN DESCRIPTIONS AND EQUIVALENT CIRCUITS

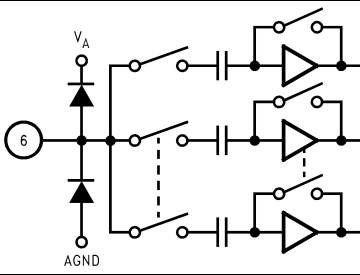
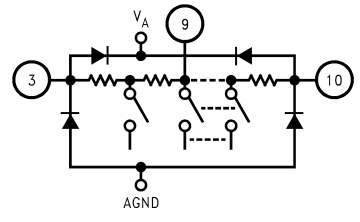
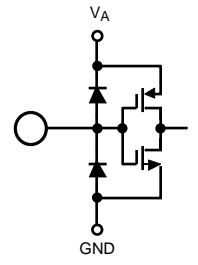
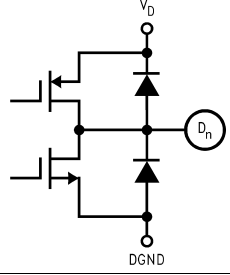
Pin No.	Symbol	Equivalent Circuit	Description
6	$V_{IN}$		Analog signal input. Conversion range is $V_{RB}$ to $V_{RT}$ .
3	$V_{RT}$		Analog Input that is the high (top) side of the reference ladder of the ADC. Nominal range is 1.0V to $V_A$ . Voltage on $V_{RT}$ and $V_{RB}$ inputs define the $V_{IN}$ conversion range. Bypass well. See <a href="#">THE ANALOG INPUT</a> for more information.
9	$V_{RM}$		Mid-point of the reference ladder. This pin should be bypassed to a clean, quiet point in the analog ground plane with a 0.1 $\mu$ F capacitor.
10	$V_{RB}$		Analog Input that is the low side (bottom) of the reference ladder of the ADC. Nominal range is 0.0V to ( $V_{RT} - 1.0$ V). Voltage on $V_{RT}$ and $V_{RB}$ inputs define the $V_{IN}$ conversion range. Bypass well. See <a href="#">THE ANALOG INPUT</a> for more information.
23	PD		Power Down input. When this pin is high, the converter is in the Power Down mode and the data output pins hold the last conversion result.
24	CLK		CMOS/TTL compatible digital clock Input. $V_{IN}$ is sampled on the falling edge of CLK input.
13 thru 16 and 19 thru 22	D0–D7		Conversion data digital Output pins. D0 is the LSB, D7 is the MSB. Valid data is output just after the rising edge of the CLK input.
7	$V_{IN}$ GND		Reference ground for the single-ended analog input, $V_{IN}$ .
1, 4, 12	$V_A$		Positive analog supply pin. Connect to a clean, quiet voltage source of +3V. $V_A$ should be bypassed with a 0.1 $\mu$ F ceramic chip capacitor for each pin, plus one 10 $\mu$ F capacitor. See <a href="#">POWER SUPPLY CONSIDERATIONS</a> for more information.
18	DR $V_D$		Power supply for the output drivers. If connected to $V_A$ , decouple well from $V_A$ .
17	DR GND		The ground return for the output driver supply.
2, 5, 8, 11	AGND		The ground return for the analog supply.



These devices have limited built-in ESD protection. The leads should be shorted together or the device placed in conductive foam during storage or handling to prevent electrostatic damage to the MOS gates.

**Absolute Maximum Ratings** (1)(2)(3)

Supply Voltage ( $V_A$ )	3.8V	
Driver Supply Voltage (DR $V_D$ )	$V_A + 0.3V$	
Voltage on Any Input or Output Pin	-0.3V to $V_A$	
Reference Voltage ( $V_{RT}$ , $V_{RB}$ )	$V_A$ to AGND	
CLK, $\overline{OE}$ Voltage Range	-0.3V to ( $V_A + 0.3V$ )	
Digital Output Voltage ( $V_{OH}$ , $V_{OL}$ )	DR GND to DR $V_D$	
Input Current at Any Pin (4)	$\pm 25$ mA	
Package Input Current (4)	$\pm 50$ mA	
Power Dissipation at $T_A = 25^\circ C$	See (5)	
ESD Susceptibility (6)	Human Body Model	2500V
	Machine Model	250V
Soldering Temperature, Infrared, 10 seconds (7)	235°C	
Storage Temperature	-65°C to +150°C	

- (1) All voltages are measured with respect to GND = AGND = DR GND = 0V, unless otherwise specified.
- (2) Absolute Maximum Ratings indicate limits beyond which damage to the device may occur, including inoperability and degradation of device reliability and/or performance. Functional operation of the device and/or non-degradation at the Absolute Maximum Ratings or other conditions beyond those indicated in the Recommended Operating Conditions is not implied. The recommended Operating Conditions indicate conditions at which the device is functional and the device should not be operated beyond such conditions.
- (3) If Military/Aerospace specified devices are required, please contact the Texas Instruments Sales Office/ Distributors for availability and specifications.
- (4) When the input voltage at any pin exceeds the power supplies (that is, less than AGND or DR GND, or greater than  $V_A$  or DR  $V_D$ ), the current at that pin should be limited to 25 mA. The 50 mA maximum package input current rating limits the number of pins that can safely exceed the power supplies with an input current of 25 mA to two.
- (5) The absolute maximum junction temperature ( $T_{Jmax}$ ) for this device is 150°C. The maximum allowable power dissipation is dictated by  $T_{Jmax}$ , the junction-to-ambient thermal resistance ( $\theta_{JA}$ ), and the ambient temperature ( $T_A$ ), and can be calculated using the formula  $P_{DMAX} = (T_{Jmax} - T_A) / \theta_{JA}$ . The values for maximum power dissipation will be reached only when this device is operated in a severe fault condition (e.g., when input or output pins are driven beyond the power supply voltages, or the power supply polarity is reversed). Obviously, such conditions should always be avoided.
- (6) Human body model is 100 pF capacitor discharged through a 1.5 k $\Omega$  resistor. Machine model is 220 pF discharged through ZERO Ohms.
- (7) See AN-450, "Surface Mounting Methods and Their Effect on Product Reliability" ().

**Operating Ratings** (1)(2)

Operating Temperature Range	$-40^\circ C \leq T_A \leq +85^\circ C$
Supply Voltage ( $V_A$ )	+2.7V to +3.6V
Driver Supply Voltage (DR $V_D$ )	+2.4V to $V_A$
Ground Difference  GND - DR GND	0V to 300 mV
Upper Reference Voltage ( $V_{RT}$ )	1.0V to ( $V_A + 0.1V$ )
Lower Reference Voltage ( $V_{RB}$ )	0V to ( $V_{RT} - 1.0V$ )
$V_{IN}$ Voltage Range	$V_{RB}$ to $V_{RT}$

- (1) Absolute Maximum Ratings indicate limits beyond which damage to the device may occur, including inoperability and degradation of device reliability and/or performance. Functional operation of the device and/or non-degradation at the Absolute Maximum Ratings or other conditions beyond those indicated in the Recommended Operating Conditions is not implied. The recommended Operating Conditions indicate conditions at which the device is functional and the device should not be operated beyond such conditions.
- (2) All voltages are measured with respect to GND = AGND = DR GND = 0V, unless otherwise specified.

### Converter Electrical Characteristics

The following specifications apply for  $V_A = DR V_D = +3.0V_{DC}$ ,  $V_{RT} = +1.9V$ ,  $V_{RB} = 0.3V$ ,  $C_L = 10\text{ pF}$ ,  $f_{CLK} = 60\text{ MHz}$  at 50% duty cycle. **Boldface limits apply for  $T_J = T_{MIN}$  to  $T_{MAX}$** ; all other limits  $T_A = 25^\circ\text{C}$  <sup>(1)(2)(3)</sup>

Symbol	Parameter	Conditions	Typical <sup>(4)</sup>	Limits <sup>(4)</sup>	Units (Limits)
<b>DC ACCURACY</b>					
INL	Integral Non-Linearity		±0.5	<b>±1.3</b>	LSB (max)
DNL	Differential Non-Linearity		±0.4	<b>+1.0</b> <b>-0.9</b>	LSB (max) LSB (min)
	Missing Codes			<b>0</b>	(max)
FSE	Full Scale Error		18	±28	mV (max)
ZSE	Zero Scale Offset Error		26	±35	mV (max)
<b>ANALOG INPUT AND REFERENCE CHARACTERISTICS</b>					
$V_{IN}$	Input Voltage		1.6	$V_{RB}$ $V_{RT}$	V (min) V (max)
$C_{IN}$	$V_{IN}$ Input Capacitance	$V_{IN} = 0.75V + 0.5\text{ Vrms}$	(CLK LOW)	3	pF
			(CLK HIGH)	4	pF
$R_{IN}$	$R_{IN}$ Input Resistance		>1		MΩ
BW	Full Power Bandwidth		200		MHz
$V_{RT}$	Top Reference Voltage		1.9	$V_A$	V (max)
				1.0	V (min)
$V_{RB}$	Bottom Reference Voltage		0.3	$V_{RT} - 1.0$	V (max)
				0	V (min)
$V_{RT} - V_{RB}$	Reference Delta		1.6	1.0	V (min)
				2.3	V (max)
$R_{REF}$	Reference Ladder Resistance	$V_{RT}$ to $V_{RB}$	220	<b>150</b>	Ω (min)
				<b>300</b>	Ω (max)
$I_{REF}$	Reference Ladder Current		7.3	<b>5.3</b>	mA (min)
				<b>10.6</b>	mA (max)

- (1) The Electrical characteristics tables list ensured specifications under the listed Recommended Conditions except as otherwise modified or specified by the Electrical Characteristics Conditions and/or Notes. Typical specifications are estimations for room temperature only and are not ensured.
- (2) The analog inputs are protected as shown below. Input voltage magnitudes up to  $V_A + 300\text{ mV}$  or to  $300\text{ mV}$  below GND will not damage this device. However, errors in the A/D conversion can occur if the input goes above  $DR V_D$  or below GND by more than  $100\text{ mV}$ . For example, if  $V_A$  is  $2.7V_{DC}$  the full-scale input voltage must be  $\leq 2.6V_{DC}$  to ensure accurate conversions.

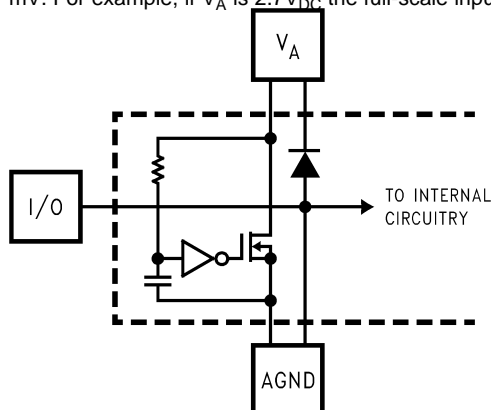

- (3) To ensure accuracy, it is required that  $V_A$  and  $DR V_D$  be well bypassed. Each supply pin must be decoupled with separate bypass capacitors.
- (4) Typical figures are at  $T_J = 25^\circ\text{C}$ , and represent most likely parametric norms at specific conditions at the time of product characterization and are not ensured. Test limits are specified to TI's AOQL (Average Outgoing Quality Level).

### Converter Electrical Characteristics (continued)

The following specifications apply for  $V_A = DR$ ,  $V_D = +3.0V_{DC}$ ,  $V_{RT} = +1.9V$ ,  $V_{RB} = 0.3V$ ,  $C_L = 10$  pF,  $f_{CLK} = 60$  MHz at 50% duty cycle. **Boldface limits apply for  $T_J = T_{MIN}$  to  $T_{MAX}$** ; all other limits  $T_A = 25^\circ C$  <sup>(1)(2)(3)</sup>

Symbol	Parameter	Conditions	Typical <sup>(4)</sup>	Limits <sup>(4)</sup>	Units (Limits)
<b>CLK, PD DIGITAL INPUT CHARACTERISTICS</b>					
$V_{IH}$	Logical High Input Voltage	DR $V_D = V_A = 3.3V$		<b>2.0</b>	V (min)
$V_{IL}$	Logical Low Input Voltage	DR $V_D = V_A = 2.7V$		<b>0.8</b>	V (max)
$I_{IH}$	Logical High Input Current	$V_{IH} = DR$ , $V_D = V_A = 3.3V$	10		nA
$I_{IL}$	Logical Low Input Current	$V_{IL} = 0V$ , DR $V_D = V_A = 2.7V$	-50		nA
$C_{IN}$	Logic Input Capacitance		3		pF
<b>DIGITAL OUTPUT CHARACTERISTICS</b>					
$V_{OH}$	High Level Output Voltage	$V_A = DR$ , $V_D = 2.7V$ , $I_{OH} = -400$ $\mu A$	2.6	<b>2.4</b>	V (min)
$V_{OL}$	Low Level Output Voltage	$V_A = DR$ , $V_D = 2.7V$ , $I_{OL} = 1.0$ mA	0.4	<b>0.5</b>	V (max)
<b>DYNAMIC PERFORMANCE</b>					
ENOB	Effective Number of Bits	$f_{IN} = 4.4$ MHz, $V_{IN} = -0.25$ dBFS	7.6		Bits
		$f_{IN} = 10$ MHz, $V_{IN} = -0.25$ dBFS	7.6	<b>7.1</b>	Bits (min)
		$f_{IN} = 25$ MHz, $V_{IN} = -0.25$ dBFS	7.5		Bits
		$f_{IN} = 29$ MHz, $V_{IN} = -0.25$ dBFS	7.4		Bits
SINAD	Signal-to-Noise & Distortion	$f_{IN} = 4.4$ MHz, $V_{IN} = -0.25$ dBFS	47		dB
		$f_{IN} = 10$ MHz, $V_{IN} = -0.25$ dBFS	47	<b>44.5</b>	dB (min)
		$f_{IN} = 25$ MHz, $V_{IN} = -0.25$ dBFS	47		dB
		$f_{IN} = 29$ MHz, $V_{IN} = -0.25$ dBFS	46		dB
SNR	Signal-to-Noise Ratio	$f_{IN} = 4.4$ MHz, $V_{IN} = -0.25$ dBFS	47		dB
		$f_{IN} = 10$ MHz, $V_{IN} = -0.25$ dBFS	47	<b>44.6</b>	dB (min)
		$f_{IN} = 25$ MHz, $V_{IN} = -0.25$ dBFS	47		dB
		$f_{IN} = 29$ MHz, $V_{IN} = -0.25$ dBFS	46		dB
SFDR	Spurious Free Dynamic Range	$f_{IN} = 4.4$ MHz, $V_{IN} = -0.25$ dBFS	64		dBc
		$f_{IN} = 10$ MHz, $V_{IN} = -0.25$ dBFS	63		dBc
		$f_{IN} = 25$ MHz, $V_{IN} = -0.25$ dBFS	60		dBc
		$f_{IN} = 29$ MHz, $V_{IN} = -0.25$ dBFS	54		dBc
THD	Total Harmonic Distortion	$f_{IN} = 4.4$ MHz, $V_{IN} = -0.25$ dBFS	-64		dBc
		$f_{IN} = 10$ MHz, $V_{IN} = -0.25$ dBFS	-63		dBc
		$f_{IN} = 25$ MHz, $V_{IN} = -0.25$ dBFS	-57		dBc
		$f_{IN} = 29$ MHz, $V_{IN} = -0.25$ dBFS	-54		dBc
HD2	2nd Harmonic Distortion	$f_{IN} = 4.4$ MHz, $V_{IN} = -0.25$ dBFS	-70		dBc
		$f_{IN} = 10$ MHz, $V_{IN} = -0.25$ dBFS	-65		dBc
		$f_{IN} = 25$ MHz, $V_{IN} = -0.25$ dBFS	-64		dBc
		$f_{IN} = 29$ MHz, $V_{IN} = -0.25$ dBFS	-54		dBc
HD3	3rd Harmonic Distortion	$f_{IN} = 4.4$ MHz, $V_{IN} = -0.25$ dBFS	-72		dBc
		$f_{IN} = 10$ MHz, $V_{IN} = -0.25$ dBFS	-70		dBc
		$f_{IN} = 25$ MHz, $V_{IN} = -0.25$ dBFS	-68		dBc
		$f_{IN} = 29$ MHz, $V_{IN} = -0.25$ dBFS	-65		dBc
IMD	Intermodulation Distortion	$f_1 = 11$ MHz, $V_{IN} = -6.25$ dBFS $f_2 = 12$ MHz, $V_{IN} = -6.25$ dBFS	-55		dBc

### Converter Electrical Characteristics (continued)

The following specifications apply for  $V_A = DR$ ,  $V_D = +3.0V_{DC}$ ,  $V_{RT} = +1.9V$ ,  $V_{RB} = 0.3V$ ,  $C_L = 10$  pF,  $f_{CLK} = 60$  MHz at 50% duty cycle. **Boldface limits apply for  $T_J = T_{MIN}$  to  $T_{MAX}$** ; all other limits  $T_A = 25^\circ C$  <sup>(1)(2)(3)</sup>

Symbol	Parameter	Conditions	Typical <sup>(4)</sup>	Limits <sup>(4)</sup>	Units (Limits)
<b>POWER SUPPLY CHARACTERISTICS</b>					
$I_A$	Analog Supply Current	DC Input	25	<b>31</b>	mA (max)
		$f_{IN} = 10$ MHz, $V_{IN} = -3$ dBFS	25		mA
$DR I_D$	Output Driver Supply Current	DC Input	0.3	1	mA (max)
		$f_{IN} = 10$ MHz, $V_{IN} = 3$ dBFS <sup>(5)</sup>	4.4		mA
$I_A + DR I_D$	Total Operating Current	DC Input	25.3	32	mA (max)
		$f_{IN} = 10$ MHz, $V_{IN} = -3$ dBFS, PD = Low	29.4		mA (max)
		CLK Low, PD = Hi	0.2		
PC	Power Consumption	DC Input	76	<b>96</b>	mW (max)
		$f_{IN} = 10$ MHz, $V_{IN} = -3$ dBFS, PD = Low	88		mW
		CLK Low, PD = Hi	0.6		mW
$PSRR_1$	Power Supply Rejection Ratio	FSE change with 2.7V to 3.3V change in $V_A$	54		dB
$PSRR_2$	Power Supply Rejection Ratio	SNR change with 200 mV at 200 kHz on supply	45		dB
<b>AC ELECTRICAL CHARACTERISTICS</b>					
$f_{C1}$	Maximum Conversion Rate		70	<b>60</b>	MHz (min)
$f_{C2}$	Minimum Conversion Rate		20		MHz
$t_{CL}$	Minimum Clock Low Time			<b>6.7</b>	ns (min)
$t_{CH}$	Minimum Clock High Time			<b>6.7</b>	ns (min)
$t_{OH}$	Output Hold Time	CLK Rise to Data Invalid	4.4		ns
$t_{OD}$	Output Delay	CLK Rise to Data Valid	8.2	<b>12</b>	ns (max)
	Pipeline Delay (Latency)		2.5		Clock Cycles
$t_{AD}$	Sampling (Aperture) Delay	CLK Fall to Acquisition of Data	1.5		ns
$t_{AJ}$	Aperture Jitter		2		ps rms

- (5)  $I_{DR}$  is the current consumed by the switching of the output drivers and is primarily determined by the load capacitance on the output pins, the supply voltage,  $V_{DR}$ , and the rate at which the outputs are switching (which is signal dependent),  $I_{DR} = V_{DR} (C_O \times f_O + C_1 \times f_1 + \dots + C_{71} \times f_7)$  where  $V_{DR}$  is the output driver power supply voltage,  $C_n$  is the total capacitance on any given output pin, and  $f_n$  is the average frequency at which that pin is toggling.

**Typical Performance Characteristics**

$V_A = DR$   $V_D = 3V$ ,  $f_{CLK} = 60$  MHz,  $f_{IN} = 10$  MHz, unless otherwise stated

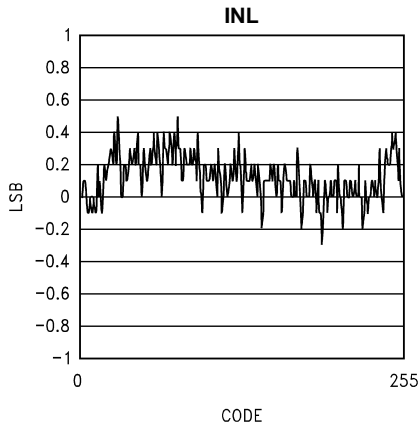

**Figure 2.**

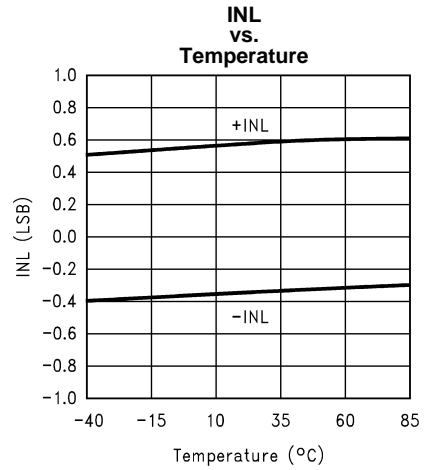

**Figure 3.**

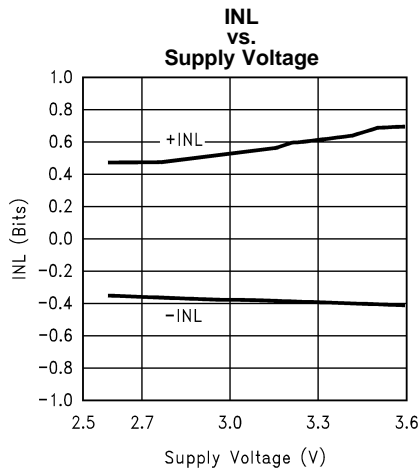

**Figure 4.**

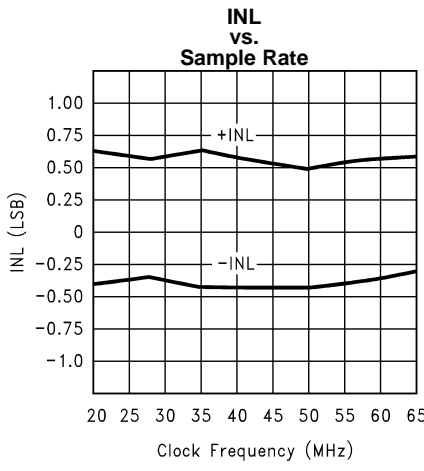

**Figure 5.**

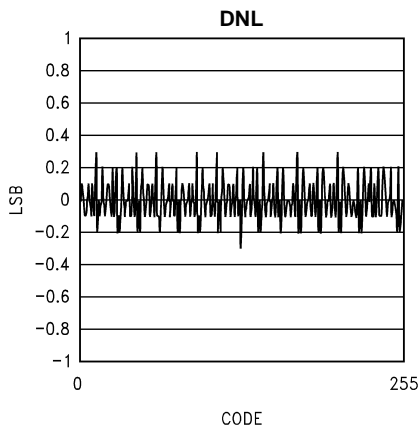

**Figure 6.**

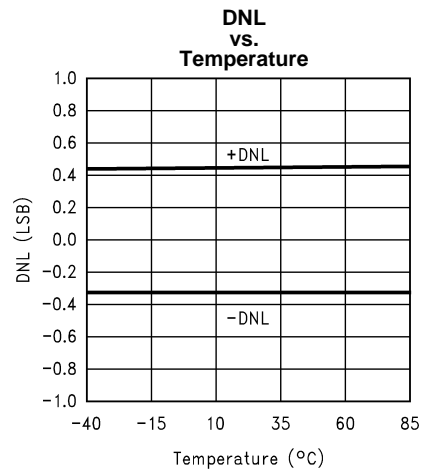

**Figure 7.**

Typical Performance Characteristics (continued)

$V_A = DR V_D = 3V$ ,  $f_{CLK} = 60$  MHz,  $f_{IN} = 10$  MHz, unless otherwise stated

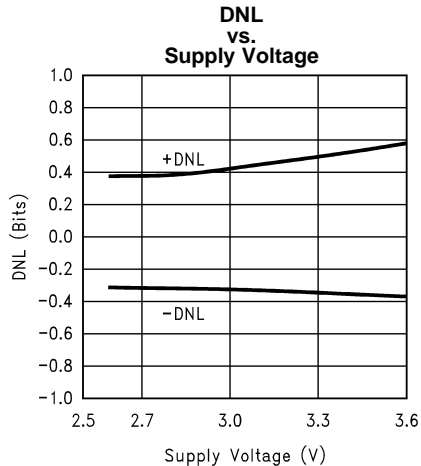

Figure 8.

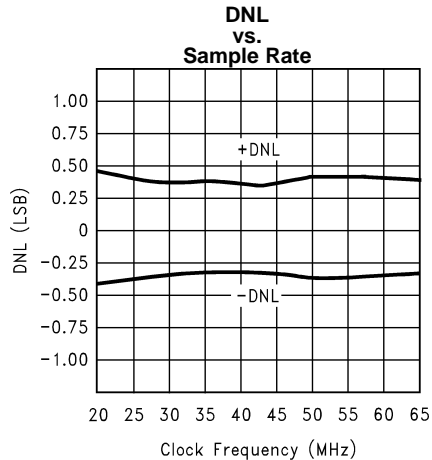

Figure 9.

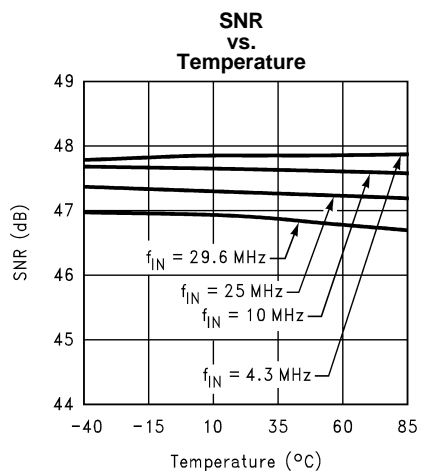

Figure 10.

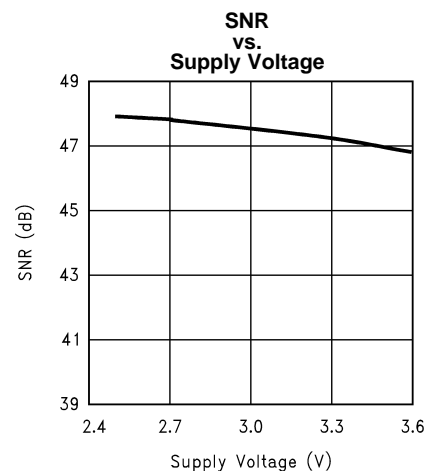

Figure 11.

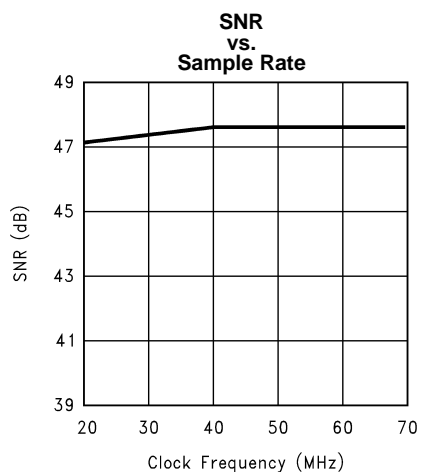

Figure 12.

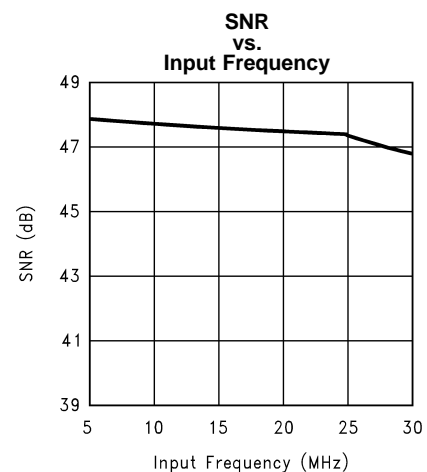
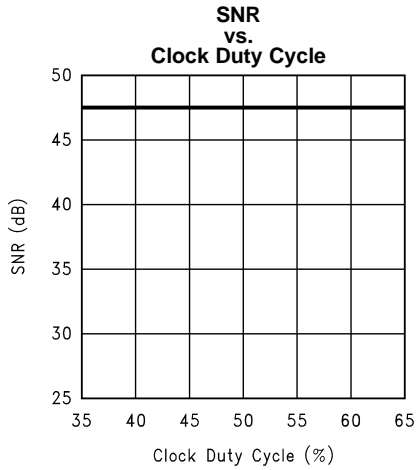

Figure 13.

**Typical Performance Characteristics (continued)**

$V_A = DR$   $V_D = 3V$ ,  $f_{CLK} = 60$  MHz,  $f_{IN} = 10$  MHz, unless otherwise stated



**Figure 14.**

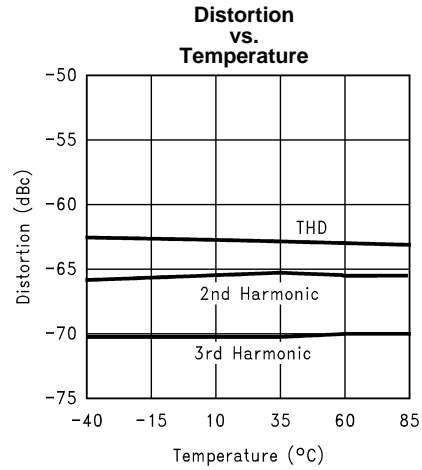

**Figure 15.**

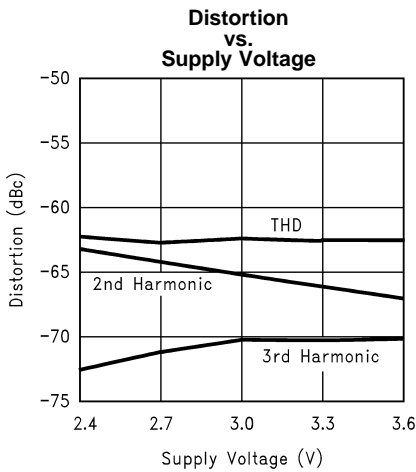

**Figure 16.**

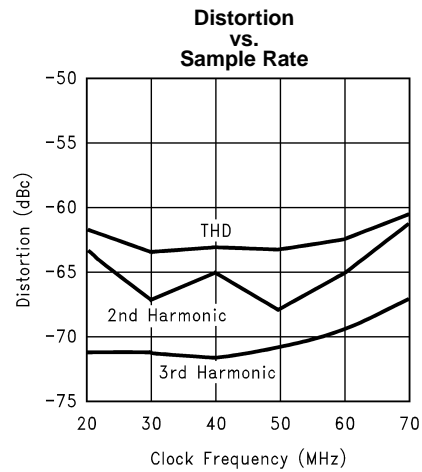

**Figure 17.**

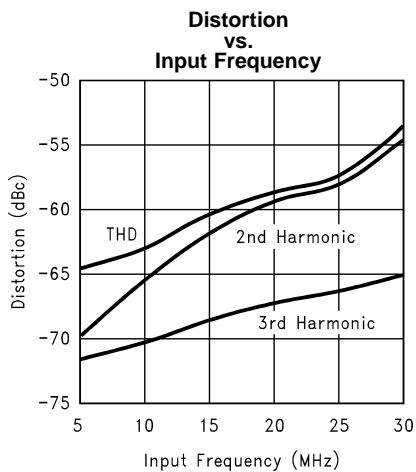

**Figure 18.**

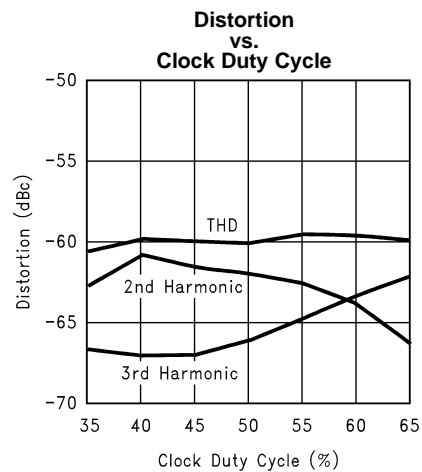

**Figure 19.**

Typical Performance Characteristics (continued)

$V_A = DR$   $V_D = 3V$ ,  $f_{CLK} = 60$  MHz,  $f_{IN} = 10$  MHz, unless otherwise stated

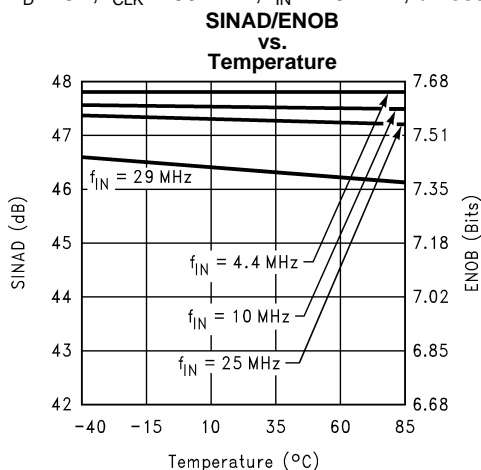

Figure 20.

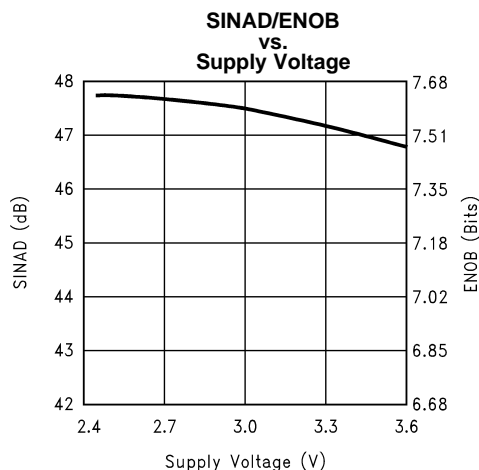

Figure 21.

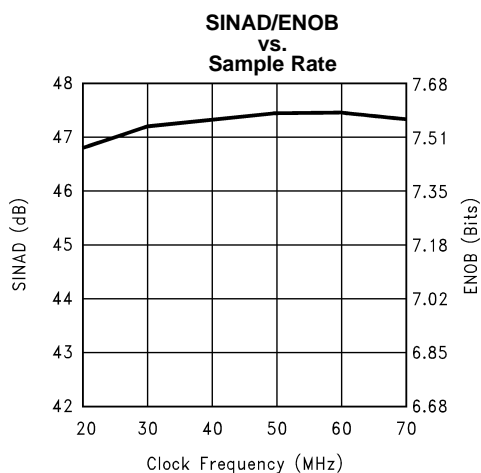

Figure 22.

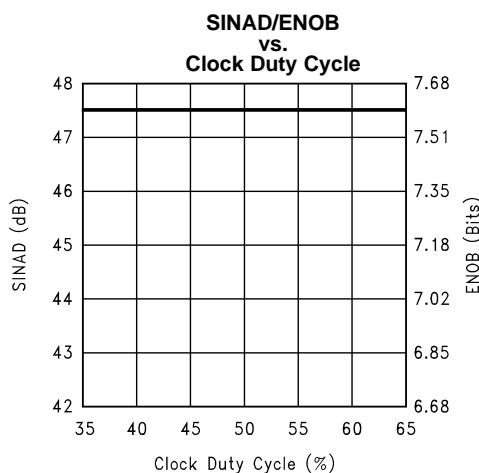

Figure 23.

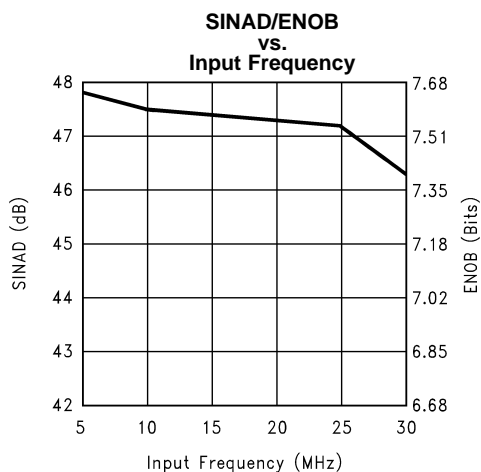

Figure 24.

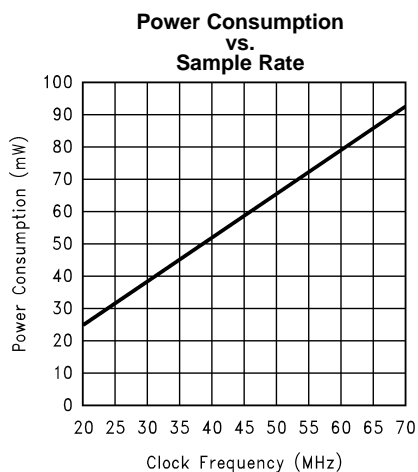
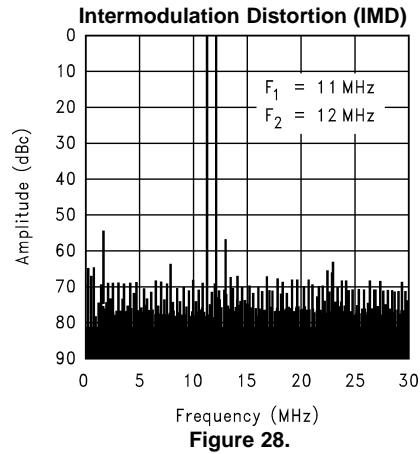
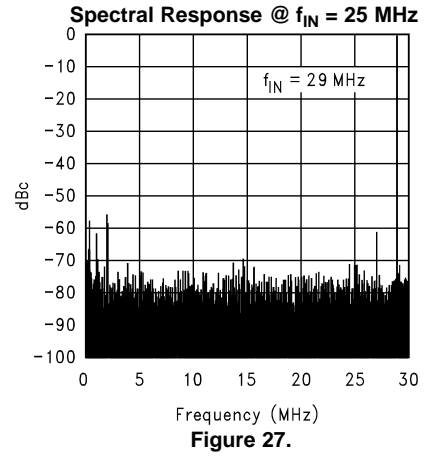
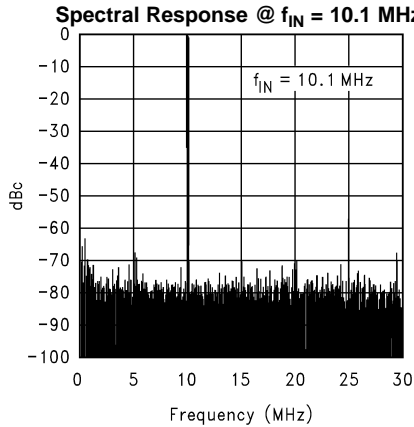

Figure 25.

**Typical Performance Characteristics (continued)**

$V_A = DR$   $V_D = 3V$ ,  $f_{CLK} = 60$  MHz,  $f_{IN} = 10$  MHz, unless otherwise stated



## Specification Definitions

**APERTURE (SAMPLING) DELAY** is that time required after the fall of the clock input for the sampling switch to open. The Sample/Hold circuit effectively stops capturing the input signal and goes into the “hold” mode  $t_{AD}$  after the clock goes low.

**APERTURE JITTER** is the variation in aperture delay from sample to sample. Aperture jitter shows up as noise at the output.

**CLOCK DUTY CYCLE** is the ratio of the time that the clock waveform is at a logic high to the total time of one clock period.

**DIFFERENTIAL NON-LINEARITY (DNL)** is the measure of the maximum deviation from the ideal step size of 1 LSB. Measured at 60 MSPS with a ramp input.

**EFFECTIVE NUMBER OF BITS (ENOB, or EFFECTIVE BITS)** is another method of specifying Signal-to-Noise and Distortion Ratio, or SINAD. ENOB is defined as  $(\text{SINAD} - 1.76) / 6.02$  and says that the converter is equivalent to a perfect ADC of this (ENOB) number of bits.

**FULL-POWER BANDWIDTH** is the frequency at which the reconstructed output fundamental drops 3 dB below its low frequency value for a full scale input.

**FULL-SCALE ERROR** is a measure of how far the last code transition is from the ideal  $1\frac{1}{2}$  LSB below  $V_{RT}$  and is defined as:

$$V_{\max} + 1.5 \text{ LSB} - V_{RT}$$

where

- $V_{\max}$  is the voltage at which the transition to the maximum (full scale) code occurs (1)

**INTEGRAL NON-LINEARITY (INL)** is a measure of the deviation of each individual code from a line drawn from zero scale ( $\frac{1}{2}$  LSB below the first code transition) through positive full scale ( $\frac{1}{2}$  LSB above the last code transition). The deviation of any given code from this straight line is measured from the center of that code value. The end point test method is used. Measured at 60 MSPS with a ramp input.

**INTERMODULATION DISTORTION (IMD)** is the creation of additional spectral components as a result of the interaction between two sinusoidal frequencies that are applied to the ADC input at the same time. IMD is the ratio of the power in the second and third order intermodulation products to the total power in the original frequencies.

**MISSING CODES** are those output codes that are skipped and will never appear at the ADC outputs. These codes cannot be reached with any input value.

**POWER SUPPLY REJECTION RATIO (PSRR)** is a measure of how well the ADC rejects a change in the power supply voltage. For the ADC08060, PSRR1 is the ratio of the change in d.c. power supply voltage to the resulting change in Full-Scale Error, expressed in dB. PSRR2 is a measure of how well an a.c. signal riding upon the power supply is rejected and is here defined as:

$$\text{PSRR2} = 20\text{Log} \left( 4 \sqrt{10^{\frac{-\text{SNR1}}{10}} - 10^{\frac{-\text{SNR0}}{10}}} \right)$$

where

- SNR0 is the SNR measured with no noise or signal on the supply lines and SNR1 is the SNR measured with a 200 kHz, 200 mV<sub>P-P</sub> signal riding upon the supply lines (2)

**OUTPUT DELAY** is the time delay after the rising edge of the input clock before the data changes at the output pins.

**OUTPUT HOLD TIME** is the length of time that the output data is valid after the rise of the input clock.

**PIPELINE DELAY (LATENCY)** is the number of clock cycles between initiation of conversion and when that data is presented to the output driver stage. New data is available at every clock cycle, but the data lags the conversion by the Pipeline Delay plus the Output Delay.

**SIGNAL TO NOISE RATIO (SNR)** is the ratio, expressed in dB, of the rms value of the input signal frequency at the output to the rms value of the sum of all other spectral components below one-half the sampling frequency, not including harmonics or d.c.

**SIGNAL TO NOISE PLUS DISTORTION (S/(N+D) or SINAD)** is the ratio, expressed in dB, of the rms value of the input signal frequency at the output to the rms value of all of the other spectral components below half the clock frequency, including harmonics but excluding d.c.

**SPURIOUS FREE DYNAMIC RANGE (SFDR)** is the difference, expressed in dB, between the rms values of the input signal frequency at the output and the peak spurious signal, where a spurious signal is any signal present in the output spectrum that is not present at the input.

**TOTAL HARMONIC DISTORTION (THD)** is the ratio, expressed in dB, of the total of the first nine harmonic levels at the output to the level of the fundamental at the output. THD is calculated as

$$THD = 20 \times \log \sqrt{\frac{f_2^2 + f_3^2 + f_4^2 + f_5^2 + f_6^2 + f_7^2 + f_8^2 + f_9^2 + f_{10}^2}{f_1^2}}$$

where

- $f_1$  is the RMS power of the fundamental (input) frequency
  - $f_2$  through  $f_{10}$  is the power in the first 9 harmonics in the output spectrum
- (3)

**ZERO SCALE OFFSET ERROR** is the error in the input voltage required to cause the first code transition. It is defined as

$$V_{OFF} = V_{ZT} - V_{RB}$$

where

- $V_{ZT}$  is the first code transition input voltage
- (4)

### Timing Diagram

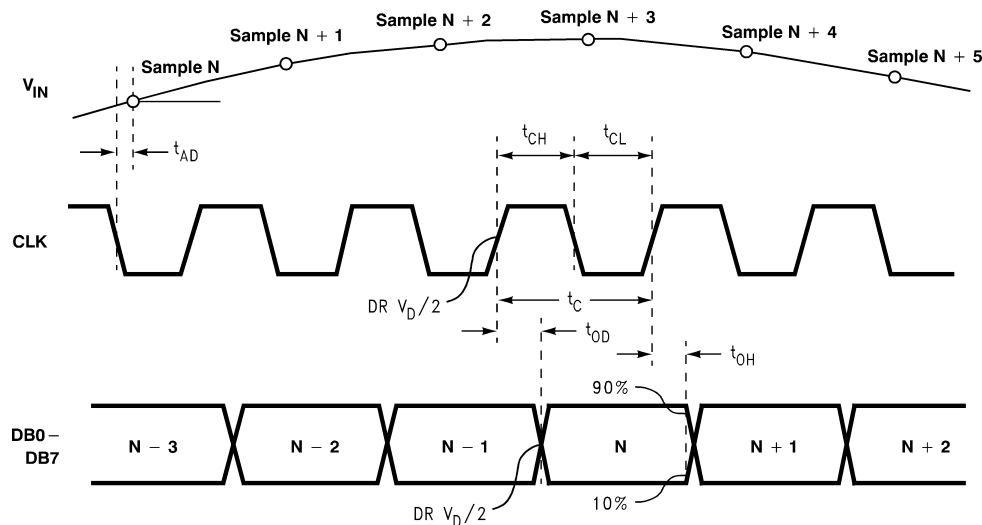

Figure 29. ADC08060 Timing Diagram

## FUNCTIONAL DESCRIPTION

The ADC08060 uses a new, unique architecture that achieves over 7.4 effective bits at input frequencies up to 30 MHz.

The analog input signal that is within the voltage range set by  $V_{RT}$  and  $V_{RB}$  is digitized to eight bits. Output format is straight binary. Input voltages below  $V_{RB}$  will cause the output word to consist of all zeroes. Input voltages above  $V_{RB}$  will cause the output word to consist of all ones.

Incorporating a switched capacitor bandgap, the ADC08060 exhibits a power consumption that is proportional to frequency, limiting power consumption to what is needed at the clock rate that is used. This and its excellent performance over a wide range of clock frequencies makes it an ideal choice as a single ADC for many 8-bit needs.

Data is acquired at the falling edge of the clock and the digital equivalent of that data is available at the digital outputs 2.5 clock cycles plus  $t_{OD}$  later. The ADC08060 will convert as long as the clock signal is present. The output coding is straight binary.

The device is in the active state when the Power Down pin (PD) is low. When the PD pin is high, the device is in the power down mode, where the output pins hold the last conversion before the PD pin went high and the device consumes just 1 mW.



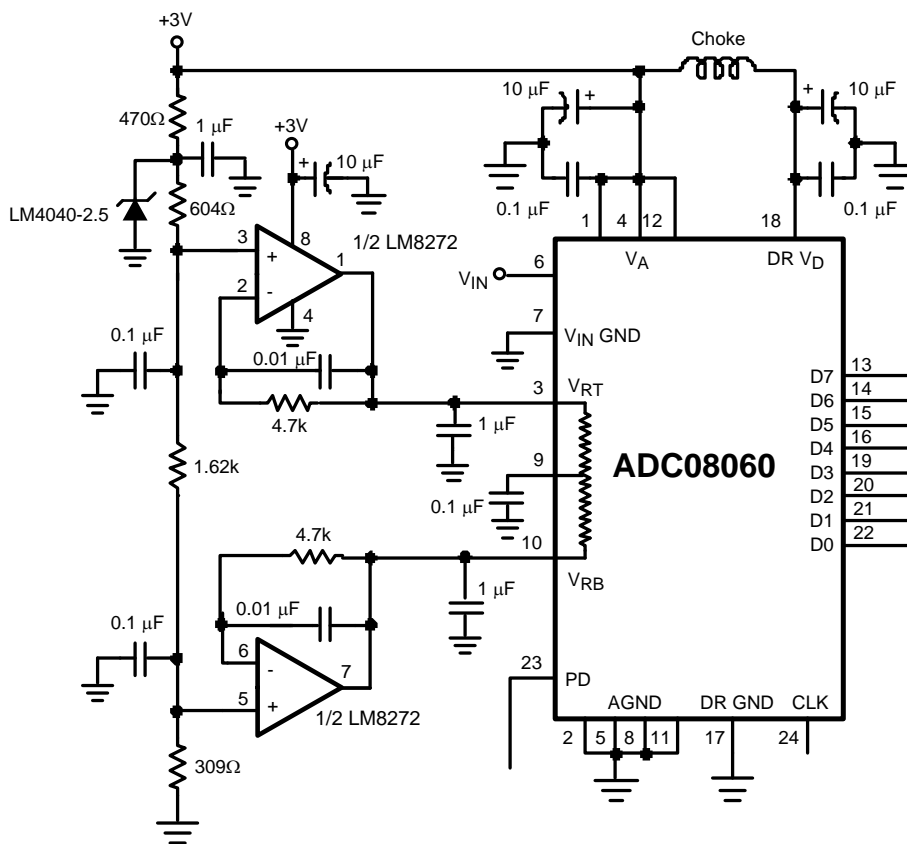

Driving the reference to force desired values requires driving with a low impedance source.

Figure 31.

## THE ANALOG INPUT

The analog input of the ADC08060 is a switch followed by an integrator. The input capacitance changes with the clock level, appearing as 3 pF when the clock is low, and 4 pF when the clock is high. The sampling nature of the analog input causes current spikes that result in voltage spikes at the analog input pin. Any circuit used to drive the analog input must be able to drive that input and to settle within the clock high time. The LMH6702 has been found to be a good amplifier to drive the ADC08060.

Figure 32 shows an example of an input circuit using the LMH6702. Any input amplifier should incorporate some gain as operational amplifiers exhibit better phase margin and transient response with gains above 2 or 3 than with unity gain. If an overall gain of less than 3 is required, attenuate the input and operate the amplifier at a higher gain, as shown in Figure 32.

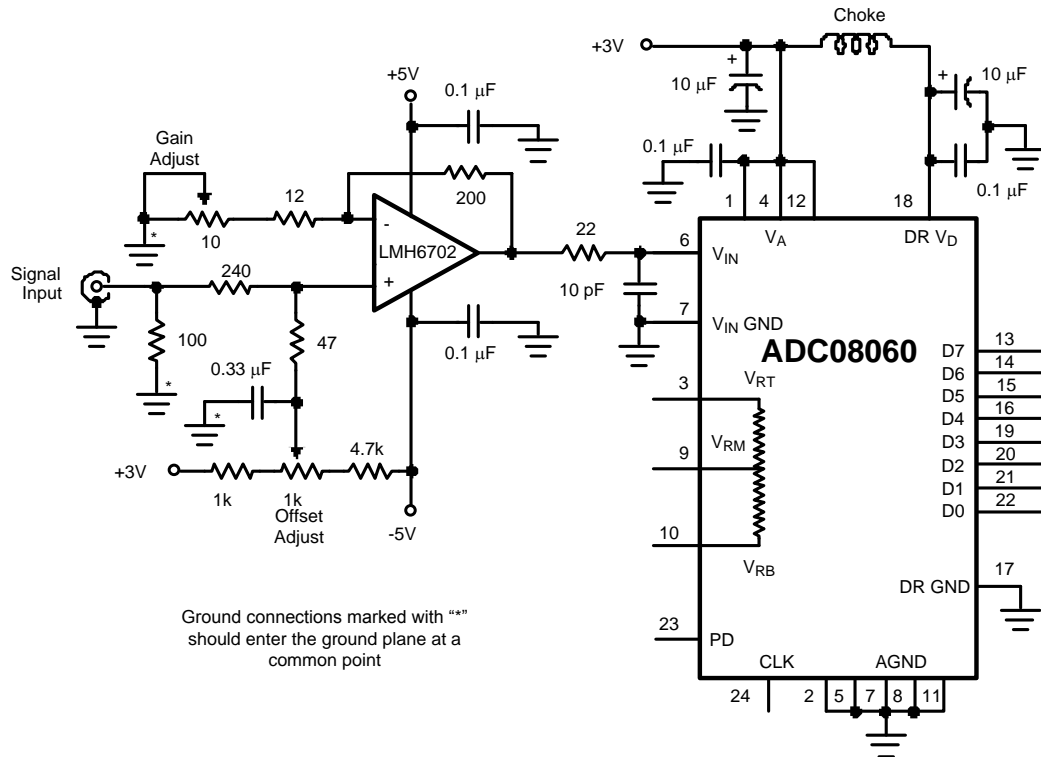

The input amplifier should incorporate some gain for best performance (see text).

**Figure 32.**

The RC at the amplifier output filters the clock rate energy that comes out of the analog input due to the input sampling circuit. The optimum time constant for this circuit depends not only upon the amplifier and ADC, but also on the circuit layout and board material. A resistor value should be chosen between 18Ω and 47Ω and the capacitor value chose according to the formula

$$C = \frac{1}{2 \cdot \pi \cdot R \cdot f_{CLK}} \quad (5)$$

This will provide optimum SNR performance. Best THD performance is realized when the capacitor and resistor values are both zero. To optimize SINAD, reduce the capacitor or resistor value until SINAD performance is optimized. That is, until  $SNR = -THD$ . This value will usually be in the range of 40% to 65% of the value calculated with the above formula. An accurate calculation is not possible because of the board material and layout dependence.

The above is intended for oversampling or Nyquist applications. There should be no resistor or capacitor between the ADC input and any amplifier for undersampling applications.

The circuit of [Figure 32](#) has both gain and offset adjustments. If you eliminate these adjustments normal circuit tolerances may cause signal clipping unless care is exercised in the worst case analysis of component tolerances and the input signal excursion is appropriately limited to account for the worst case conditions. Of course, this means that the designer will not be able to depend upon getting a full scale output with maximum signal input.

## POWER SUPPLY CONSIDERATIONS

A/D converters draw sufficient transient current to corrupt their own power supplies if not adequately bypassed. A 10 μF tantalum or aluminum electrolytic capacitor should be placed within an inch (2.5 cm) of the A/D power pins, with a 0.1 μF ceramic chip capacitor placed within one centimeter of the converter's power supply pins. Leadless chip capacitors are preferred because they have low lead inductance.

While a single voltage source is recommended for the  $V_A$  and DR  $V_D$  supplies of the ADC08060, these supply pins should be well isolated from each other to prevent any digital noise from being coupled into the analog portions of the ADC. A choke or  $27\Omega$  resistor is recommended between these supply lines with adequate bypass capacitors close to the supply pins.

As is the case with all high speed converters, the ADC08060 should be assumed to have little power supply rejection. None of the supplies for the converter should be the supply that is used for other digital circuitry in any system with a lot of digital power being consumed. The ADC supplies should be the same supply used for other analog circuitry.

No pin should ever have a voltage on it that is in excess of the supply voltage or below ground by more than 300 mV, not even on a transient basis. This can be a problem upon application of power and power shut-down. Be sure that the supplies to circuits driving any of the input pins, analog or digital, do not come up any faster than does the voltage at the ADC08060 power pins.

## THE DIGITAL INPUT PINS

The ADC08060 has two digital input pins: The PD pin and the Clock pin.

### The PD Pin

The Power Down (PD) pin, when high, puts the ADC08060 into a low power mode where power consumption is reduced to 1 mW. Output data is valid and accurate about 1 microsecond after the PD pin is brought low.

The digital output pins retain the last conversion output code when either the clock is stopped or the PD pin is high.

### The ADC08060 Clock

Although the ADC08060 is tested and its performance is ensured with a 60 MHz clock, it typically will function well with clock frequencies from 20 MHz to 70 MHz.

Halting the clock will provide nearly as much power saving as raising the PD pin high. Typical power consumption with a stopped clock is 3 mW, compared to 1 mW when PD is high. The digital outputs will remain in the same state as they were before the clock was halted.

Once the clock is restored (or the PD pin is brought low), there is a time of about 1  $\mu$ s before the output data is valid. However, because of the linear relationship between total power consumption and clock frequency, the part requires about 1  $\mu$ s after the clock is restarted or substantially changed in frequency before the part returns to its specified accuracy.

The low and high times of the clock signal can affect the performance of any A/D Converter. Because achieving a precise duty cycle is difficult, the ADC08060 is designed to maintain performance over a range of duty cycles. While it is specified and performance is ensured with a 50% clock duty cycle and 60 Msps, ADC08060 performance is typically maintained with clock high and low times of 3.3 ns, corresponding to a clock duty cycle range of 40% to 50% with a 60 MHz clock. Note that the clock minimum high and low times may not be used simultaneously.

The **CLOCK** line should be series terminated at the clock source in the characteristic impedance of that line. If the clock line is longer than

$$\frac{t_r}{6 \times t_{PD}}$$

where

- $t_r$  is the clock rise time
- $t_{PD}$  is the propagation rate of the signal along the trace

(6)

If the clock source is used to drive more than just the ADD08060, the **CLOCK** pin should be a.c. terminated with a series RC to ground such that the resistor value is equal to the characteristic impedance of the clock line and the capacitor value is

$$C \geq \frac{4 \times t_{PD} \times L}{Z_o}$$

where

- $t_{PD}$  is the signal propagation rate down the clock line, "L" is the line length
- $Z_0$  is the characteristic impedance of the clock line

(7)

This termination should be located as close as possible to, but within one centimeter of, the ADC08060 clock pin. Further, the termination should be beyond the ADC08060 clock pin as seen from the clock source. Typical  $t_{PD}$  is about 150 ps/inch on FR-4 board material. For FR-4 board material, the value of C becomes

$$C \geq \frac{6 \times 10^{-10} \times L}{Z_0}$$

where

- L is the length of the clock line in inches

(8)

## LAYOUT AND GROUNDING

Proper grounding and proper routing of all signals are essential to ensure accurate conversion. A combined analog and digital ground plane should be used.

Since digital switching transients are composed largely of high frequency components, total ground plane copper weight will have little effect upon the logic-generated noise because of the skin effect. Total surface area is more important than is total ground plane volume. Capacitive coupling between the typically noisy digital circuitry and the sensitive analog circuitry can lead to poor performance that may seem impossible to isolate and remedy. The solution is to keep the analog circuitry well separated from the digital circuitry.

The DR GND connection to the ground plane should not use the same feedthrough used by other ground connections.

High power digital components should not be located on or near a straight line between the ADC (or any linear component) and the power supply area as the resulting common return current path could cause fluctuation in the analog "ground" return of the ADC.

Generally, analog and digital lines should cross each other at 90° to avoid getting digital noise into the analog path. In high frequency systems, however, avoid crossing analog and digital lines altogether. Clock lines should be isolated from ALL other lines, analog AND digital. Even the generally accepted 90° crossing should be avoided as even a little coupling can cause problems at high frequencies. Best performance at high frequencies is obtained with a straight signal path.

The analog input should be isolated from noisy signal traces to avoid coupling of spurious signals into the input. Any external component (e.g., a filter capacitor) connected between the converter's input and ground should be connected to a very clean point in the analog ground plane.

[Figure 33](#) gives an example of a suitable layout. All analog circuitry (input amplifiers, filters, reference components, etc.) should be placed together away from any digital components.

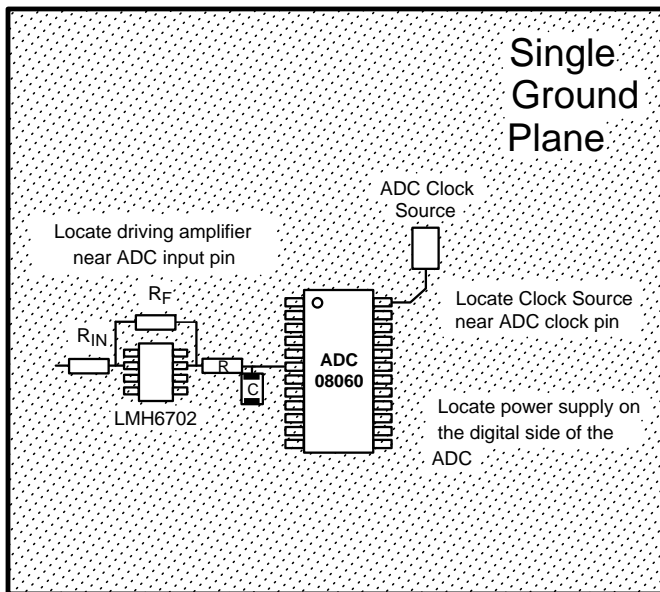

Figure 33. Layout Example

### DYNAMIC PERFORMANCE

The ADC08060 is a.c. tested and its dynamic performance is ensured. To meet the published specifications, the clock source driving the CLK input must exhibit less than 10 ps (rms) of jitter. For best a.c. performance, isolating the ADC clock from any digital circuitry should be done with adequate buffers, as with a clock tree. See [Figure 34](#).

It is good practice to keep the ADC clock line as short as possible and to keep it well away from any other signals. Other signals can introduce jitter into the clock signal. The clock signal can also introduce noise into the analog path.

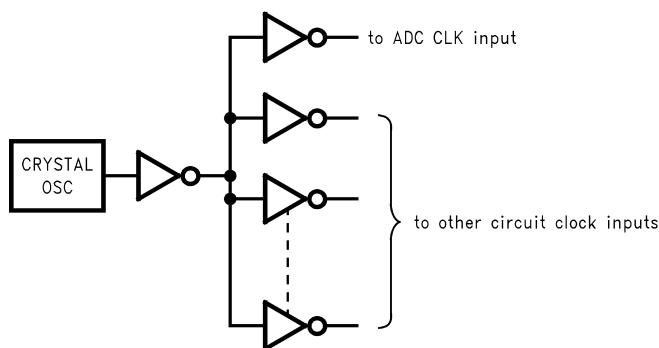

Figure 34. Isolating the ADC Clock from Digital Circuitry

### COMMON APPLICATION PITFALLS

**Driving the inputs (analog or digital) beyond the power supply rails.** For proper operation, all inputs should not go more than 300 mV below the ground pins or 300 mV above the supply pins. Exceeding these limits on even a transient basis may cause faulty or erratic operation. It is not uncommon for high speed digital circuits (e.g., 74F and 74AC devices) to exhibit undershoot that goes more than a volt below ground. A 51Ω resistor in series with the offending digital input will usually eliminate the problem.

Care should be taken not to overdrive the inputs of the ADC08060. Such practice may lead to conversion inaccuracies and even to device damage.

**Attempting to drive a high capacitance digital data bus.** The more capacitance the output drivers must charge for each conversion, the more instantaneous digital current is required from DR  $V_D$  and DR GND. These large charging current spikes can couple into the analog section, degrading dynamic performance. Buffering the digital data outputs (with a 74F541, for example) may be necessary if the data bus capacitance exceeds 10 pF. Dynamic performance can also be improved by adding 100 $\Omega$  series resistors at each digital output, reducing the energy coupled back into the converter input pins.

**Using an inadequate amplifier to drive the analog input.** As explained in [THE ANALOG INPUT](#), the capacitance seen at the input alternates between 3 pF and 4 pF with the clock. This dynamic capacitance is more difficult to drive than is a fixed capacitance, and should be considered when choosing a driving device. The LMH6702 has been found to be a good device for driving the ADC08060.

**Driving the  $V_{RT}$  pin or the  $V_{RB}$  pin with devices that can not source or sink the current required by the ladder.** As mentioned in [REFERENCE INPUTS](#), care should be taken to see that any driving devices can source sufficient current into the  $V_{RT}$  pin and sink sufficient current from the  $V_{RB}$  pin. If these pins are not driven with devices than can handle the required current, these reference pins will not be stable, resulting in a reduction of dynamic performance.

**Using a clock source with excessive jitter, using an excessively long clock signal trace, or having other signals coupled to the clock signal trace.** This will cause the sampling interval to vary, causing excessive output noise and a reduction in SNR performance. The use of simple gates with RC timing is generally inadequate as a clock source.

---

**REVISION HISTORY**

<b>Changes from Revision G (March 2013) to Revision H</b>	<b>Page</b>
<hr/> <ul style="list-style-type: none"><li>• Changed layout of National Data Sheet to TI format .....</li></ul>	<hr/> <a href="#">22</a>

**PACKAGING INFORMATION**

Orderable Device	Status (1)	Package Type	Package Drawing	Pins	Package Qty	Eco Plan (2)	Lead/Ball Finish	MSL Peak Temp (3)	Op Temp (°C)	Top-Side Markings (4)	Samples
ADC08060CIMT/NOPB	ACTIVE	TSSOP	PW	24	61	Green (RoHS & no Sb/Br)	CU SN	Level-1-260C-UNLIM	-40 to 85	ADC08060 CIMT	<a href="#">Samples</a>
ADC08060CIMTX/NOPB	ACTIVE	TSSOP	PW	24	2500	Green (RoHS & no Sb/Br)	CU SN	Level-1-260C-UNLIM	-40 to 85	ADC08060 CIMT	<a href="#">Samples</a>

(1) The marketing status values are defined as follows:

**ACTIVE:** Product device recommended for new designs.

**LIFEBUY:** TI has announced that the device will be discontinued, and a lifetime-buy period is in effect.

**NRND:** Not recommended for new designs. Device is in production to support existing customers, but TI does not recommend using this part in a new design.

**PREVIEW:** Device has been announced but is not in production. Samples may or may not be available.

**OBSOLETE:** TI has discontinued the production of the device.

(2) Eco Plan - The planned eco-friendly classification: Pb-Free (RoHS), Pb-Free (RoHS Exempt), or Green (RoHS & no Sb/Br) - please check <http://www.ti.com/productcontent> for the latest availability information and additional product content details.

**TBD:** The Pb-Free/Green conversion plan has not been defined.

**Pb-Free (RoHS):** TI's terms "Lead-Free" or "Pb-Free" mean semiconductor products that are compatible with the current RoHS requirements for all 6 substances, including the requirement that lead not exceed 0.1% by weight in homogeneous materials. Where designed to be soldered at high temperatures, TI Pb-Free products are suitable for use in specified lead-free processes.

**Pb-Free (RoHS Exempt):** This component has a RoHS exemption for either 1) lead-based flip-chip solder bumps used between the die and package, or 2) lead-based die adhesive used between the die and leadframe. The component is otherwise considered Pb-Free (RoHS compatible) as defined above.

**Green (RoHS & no Sb/Br):** TI defines "Green" to mean Pb-Free (RoHS compatible), and free of Bromine (Br) and Antimony (Sb) based flame retardants (Br or Sb do not exceed 0.1% by weight in homogeneous material)

(3) MSL, Peak Temp. -- The Moisture Sensitivity Level rating according to the JEDEC industry standard classifications, and peak solder temperature.

(4) Multiple Top-Side Markings will be inside parentheses. Only one Top-Side Marking contained in parentheses and separated by a "~" will appear on a device. If a line is indented then it is a continuation of the previous line and the two combined represent the entire Top-Side Marking for that device.

**Important Information and Disclaimer:** The information provided on this page represents TI's knowledge and belief as of the date that it is provided. TI bases its knowledge and belief on information provided by third parties, and makes no representation or warranty as to the accuracy of such information. Efforts are underway to better integrate information from third parties. TI has taken and continues to take reasonable steps to provide representative and accurate information but may not have conducted destructive testing or chemical analysis on incoming materials and chemicals. TI and TI suppliers consider certain information to be proprietary, and thus CAS numbers and other limited information may not be available for release.

In no event shall TI's liability arising out of such information exceed the total purchase price of the TI part(s) at issue in this document sold by TI to Customer on an annual basis.

## TAPE AND REEL INFORMATION



### QUADRANT ASSIGNMENTS FOR PIN 1 ORIENTATION IN TAPE



\*All dimensions are nominal

Device	Package Type	Package Drawing	Pins	SPQ	Reel Diameter (mm)	Reel Width W1 (mm)	A0 (mm)	B0 (mm)	K0 (mm)	P1 (mm)	W (mm)	Pin1 Quadrant
ADC08060CIMTX/NOPB	TSSOP	PW	24	2500	330.0	16.4	6.95	8.3	1.6	8.0	16.0	Q1

**TAPE AND REEL BOX DIMENSIONS**



\*All dimensions are nominal

Device	Package Type	Package Drawing	Pins	SPQ	Length (mm)	Width (mm)	Height (mm)
ADC08060CIMTX/NOPB	TSSOP	PW	24	2500	367.0	367.0	35.0

PW0024A

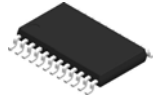

# PACKAGE OUTLINE

## TSSOP - 1.2 mm max height

SMALL OUTLINE PACKAGE

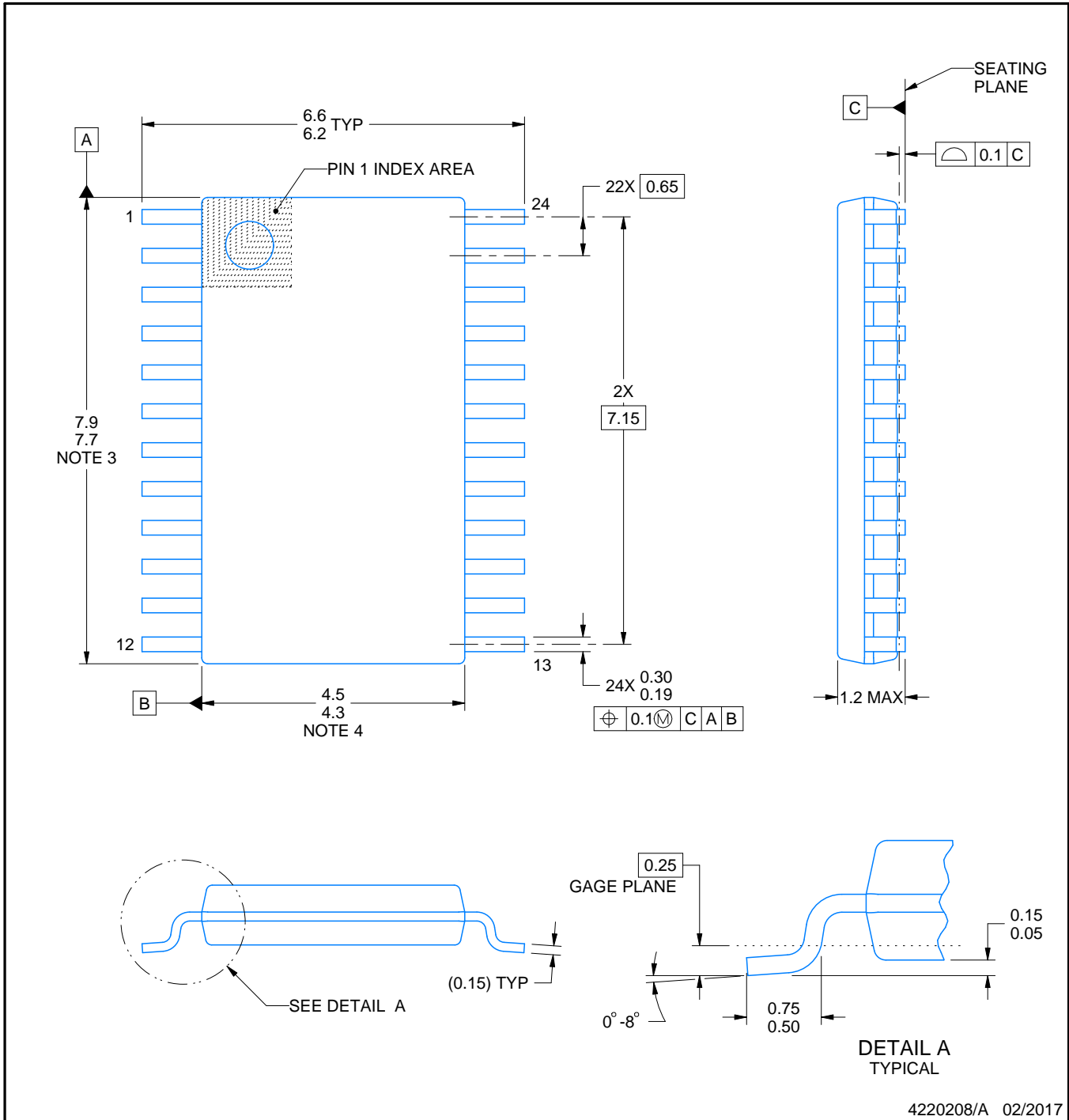

4220208/A 02/2017

### NOTES:

1. All linear dimensions are in millimeters. Any dimensions in parenthesis are for reference only. Dimensioning and tolerancing per ASME Y14.5M.
2. This drawing is subject to change without notice.
3. This dimension does not include mold flash, protrusions, or gate burrs. Mold flash, protrusions, or gate burrs shall not exceed 0.15 mm per side.
4. This dimension does not include interlead flash. Interlead flash shall not exceed 0.25 mm per side.
5. Reference JEDEC registration MO-153.

# EXAMPLE BOARD LAYOUT

PW0024A

TSSOP - 1.2 mm max height

SMALL OUTLINE PACKAGE

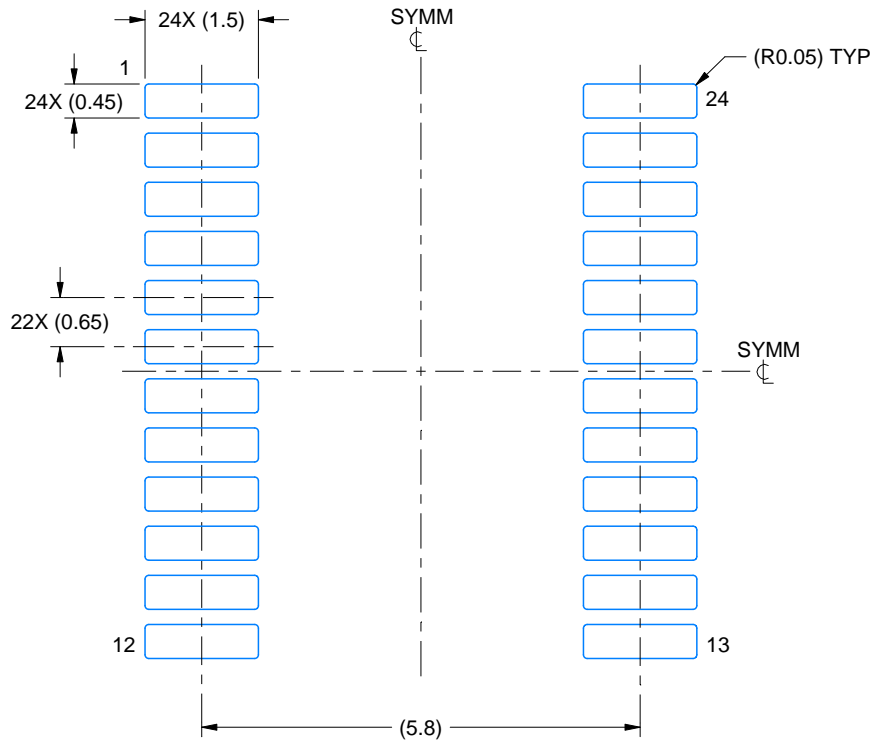

LAND PATTERN EXAMPLE  
EXPOSED METAL SHOWN  
SCALE: 10X

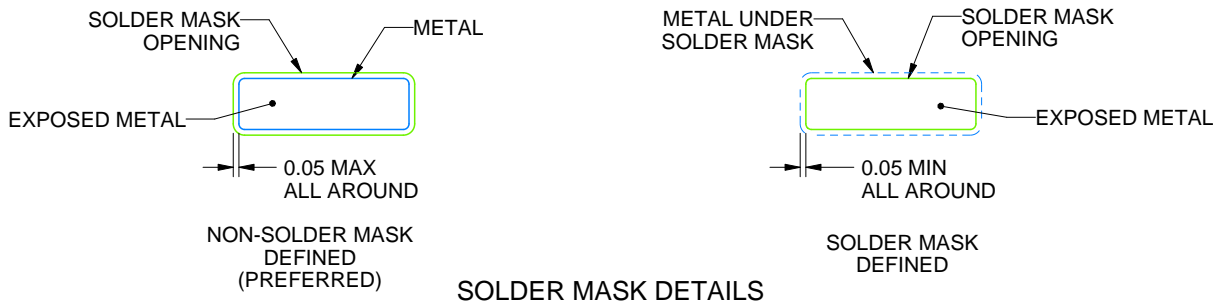

SOLDER MASK DETAILS

4220208/A 02/2017

NOTES: (continued)

- 6. Publication IPC-7351 may have alternate designs.
- 7. Solder mask tolerances between and around signal pads can vary based on board fabrication site.

# EXAMPLE STENCIL DESIGN

PW0024A

TSSOP - 1.2 mm max height

SMALL OUTLINE PACKAGE

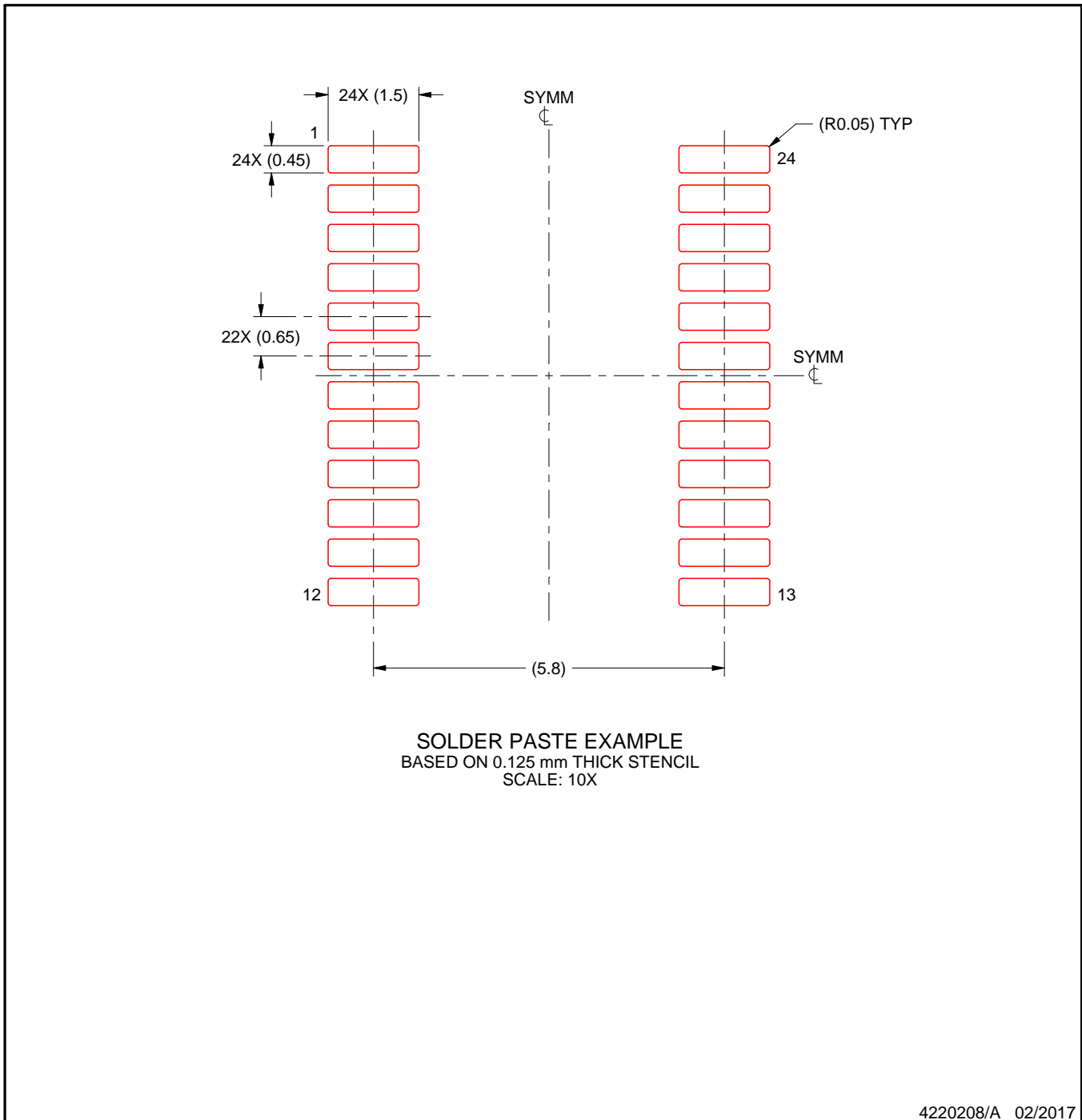

NOTES: (continued)

8. Laser cutting apertures with trapezoidal walls and rounded corners may offer better paste release. IPC-7525 may have alternate design recommendations.
9. Board assembly site may have different recommendations for stencil design.

## IMPORTANT NOTICE AND DISCLAIMER

TI PROVIDES TECHNICAL AND RELIABILITY DATA (INCLUDING DATASHEETS), DESIGN RESOURCES (INCLUDING REFERENCE DESIGNS), APPLICATION OR OTHER DESIGN ADVICE, WEB TOOLS, SAFETY INFORMATION, AND OTHER RESOURCES "AS IS" AND WITH ALL FAULTS, AND DISCLAIMS ALL WARRANTIES, EXPRESS AND IMPLIED, INCLUDING WITHOUT LIMITATION ANY IMPLIED WARRANTIES OF MERCHANTABILITY, FITNESS FOR A PARTICULAR PURPOSE OR NON-INFRINGEMENT OF THIRD PARTY INTELLECTUAL PROPERTY RIGHTS.

These resources are intended for skilled developers designing with TI products. You are solely responsible for (1) selecting the appropriate TI products for your application, (2) designing, validating and testing your application, and (3) ensuring your application meets applicable standards, and any other safety, security, or other requirements. These resources are subject to change without notice. TI grants you permission to use these resources only for development of an application that uses the TI products described in the resource. Other reproduction and display of these resources is prohibited. No license is granted to any other TI intellectual property right or to any third party intellectual property right. TI disclaims responsibility for, and you will fully indemnify TI and its representatives against, any claims, damages, costs, losses, and liabilities arising out of your use of these resources.

TI's products are provided subject to TI's Terms of Sale ([www.ti.com/legal/termsofsale.html](http://www.ti.com/legal/termsofsale.html)) or other applicable terms available either on [ti.com](http://ti.com) or provided in conjunction with such TI products. TI's provision of these resources does not expand or otherwise alter TI's applicable warranties or warranty disclaimers for TI products.

Mailing Address: Texas Instruments, Post Office Box 655303, Dallas, Texas 75265  
Copyright © 2019, Texas Instruments Incorporated

## Looking for pricing, stock, or lifecycle information?

Click below to explore more details on WIN SOURCE:

 [View ADC08060CIMTX/NOPB on WIN SOURCE](#)

 [Texas Instruments](#) Information

## Optimize Your Supply Chain with WIN SOURCE Solutions

-  Global Sourcing Solution
-  Obsolete Management
-  Cost Control Management
-  Shortage Management
-  Alternative Solution
-  Excess Inventory Management