



# MAX3221E 3-V to 5.5-V Single-Channel RS-232 Line Driver/Receiver

## With ±15-kV IEC ESD Protection

### 1 Features

- ESD Protection for RS-232 Pins
  - ±15-kV Human-Body Model (HBM)
  - ±8 kV (IEC 61000-4-2, Contact Discharge)
  - ±15 kV (IEC 61000-4-2, Air-Gap Discharge)
- Meets or Exceeds the Requirements of TIA/EIA-232-F and ITU v.28 Standards
- Operates With 3-V to 5.5-V  $V_{CC}$  Supply
- Operates up to 250 kbit/s
- One Driver and One Receiver
- Low Standby Current: 1  $\mu$ A Typical
- Accepts 5-V Logic Input With 3.3-V Supply
- Auto-Power-Down Feature Automatically Disables Drivers for Power Savings
- Alternative High-Speed Device (1 Mbit/s)
  - SN75C3221E and SN65C3221E

### 2 Applications

- Battery-Powered, Hand-Held, and Portable Equipment
- Notebooks and Laptops
- Mobile Phones and Wireless Devices

### 3 Description

The MAX3221E is a single driver, single receiver RS-232 solution operating from a single  $V_{CC}$  supply. The RS-232 pins provide IEC 61000-4-2 ESD protection. The device meets the requirements of TIA/EIA-232-F and provides the electrical interface between an asynchronous communication controller and the serial-port connector. The charge pump and four small external capacitors allow operation from a single 3-V to 5.5-V supply. These devices operate at data signaling rates up to 250 kbit/s and a maximum of 30-V/ $\mu$ s driver output slew rate.

Flexible control options for power management are available. Auto-power down disables driver and charge pump when the receiver is disconnected or the remote driver is power down. The drivers can be manually enabled or disabled. INVALID output goes low when receiver input is unconnected or power off.

#### Device Information<sup>(1)</sup>

PART NUMBER	PACKAGE	BODY SIZE (NOM)
MAX3221ECDB, MAX3221EIDB	SSOP (16)	6.20 mm x 5.30 mm
MAX3221ECPW, MAX3221EIPW	TSSOP (16)	5.00 mm x 4.40 mm

(1) For all available packages, see the orderable addendum at the end of the data sheet.

#### Block Diagram

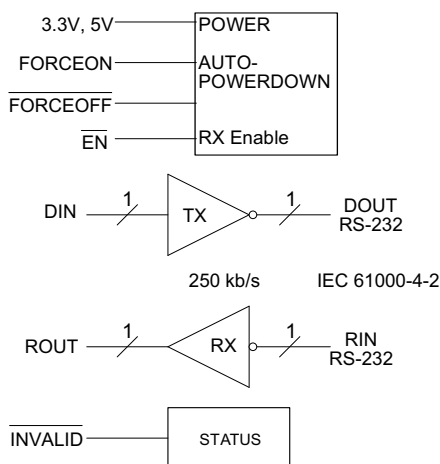

Copyright © 2016, Texas Instruments Incorporated



## Table of Contents

<b>1</b>	<b>Features</b> .....	<b>1</b>	<b>8</b>	<b>Detailed Description</b> .....	<b>11</b>
<b>2</b>	<b>Applications</b> .....	<b>1</b>	8.1	Overview .....	11
<b>3</b>	<b>Description</b> .....	<b>1</b>	8.2	Functional Block Diagram .....	11
<b>4</b>	<b>Revision History</b> .....	<b>2</b>	8.3	Feature Description .....	11
<b>5</b>	<b>Pin Configuration and Functions</b> .....	<b>3</b>	8.4	Device Functional Modes .....	12
<b>6</b>	<b>Specifications</b> .....	<b>4</b>	<b>9</b>	<b>Application and Implementation</b> .....	<b>13</b>
6.1	Absolute Maximum Ratings .....	4	9.1	Application Information .....	13
6.2	ESD Ratings .....	4	9.2	Typical Application .....	13
6.3	Recommended Operating Conditions .....	4	<b>10</b>	<b>Power Supply Recommendations</b> .....	<b>16</b>
6.4	Thermal Information .....	5	<b>11</b>	<b>Layout</b> .....	<b>16</b>
6.5	Electrical Characteristics .....	5	11.1	Layout Guidelines .....	16
6.6	Electrical Characteristics: Driver .....	5	11.2	Layout Example .....	16
6.7	Electrical Characteristics: Receiver .....	6	<b>12</b>	<b>Device and Documentation Support</b> .....	<b>17</b>
6.8	Electrical Characteristics: Auto-Power Down .....	6	12.1	Receiving Notification of Documentation Updates .....	17
6.9	Switching Characteristics: Driver .....	6	12.2	Community Resource .....	17
6.10	Switching Characteristics: Receiver .....	6	12.3	Trademarks .....	17
6.11	Switching Characteristics: Auto-Power Down .....	7	12.4	Electrostatic Discharge Caution .....	17
6.12	Typical Characteristics .....	7	12.5	Glossary .....	17
<b>7</b>	<b>Parameter Measurement Information</b> .....	<b>8</b>	<b>13</b>	<b>Mechanical, Packaging, and Orderable Information</b> .....	<b>17</b>

## 4 Revision History

NOTE: Page numbers for previous revisions may differ from page numbers in the current version.

Changes from Revision A (May 2006) to Revision B	Page
• Added <i>ESD Ratings</i> table, <i>Feature Description</i> section, <i>Device Functional Modes</i> , <i>Application and Implementation</i> section, <i>Power Supply Recommendations</i> section, <i>Layout</i> section, <i>Device and Documentation Support</i> section, and <i>Mechanical, Packaging, and Orderable Information</i> section .....	1
• Deleted <i>Ordering Information</i> table; see the POA at the end of the data sheet .....	1
• Changed R <sub>0JA</sub> thermal values: 82 to 92 for DB package and 108 to 100.3 for PW Package .....	5

## 5 Pin Configuration and Functions

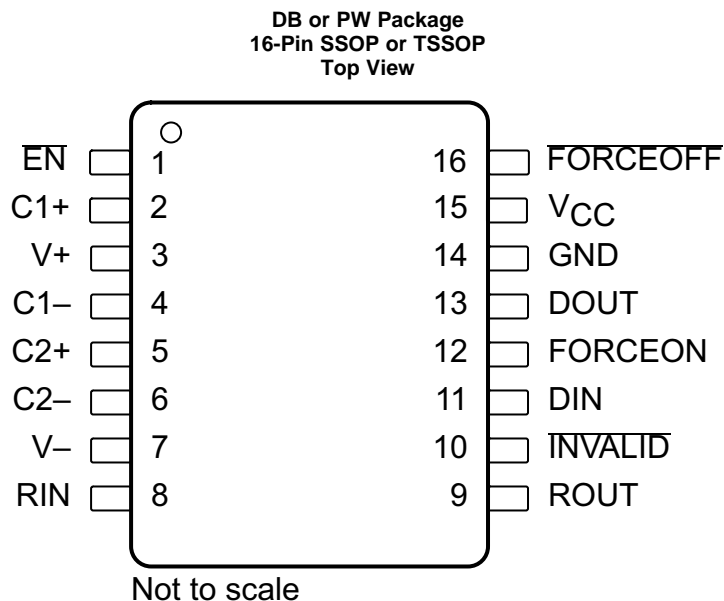

### Pin Functions

PIN		I/O	DESCRIPTION
NAME	NO.		
C1+	2	—	Positive terminals of the voltage-doubler charge pump capacitors
C2+	5		
C1–	4		
C2–	6		
DIN	11	I	Driver input
DOUT	13	O	RS-232 driver output
$\overline{\text{EN}}$	1	I	Low input enables receiver ROUT output. High input sets ROUT to high impedance.
$\overline{\text{FORCEOFF}}$	16	I	Automatic power-down control input
FORCEON	12	I	Automatic power-down control input
GND	14	—	Ground
$\overline{\text{INVALID}}$	10	O	Invalid output pin. Output low when RIN input is unpowered.
RIN	8	I	RS-232 receiver input
ROUT	9	O	Receiver output
V <sub>CC</sub>	15	—	3-V to 5.5-V supply voltage
V+	3	O	5.5-V supply generated by the charge pump
V–	7	O	–5.5-V supply generated by the charge pump

## 6 Specifications

### 6.1 Absolute Maximum Ratings

over operating free-air temperature range (unless otherwise noted)<sup>(1)</sup>

		MIN	MAX	UNIT	
V <sub>CC</sub>	Supply voltage <sup>(2)</sup>	-0.3	6	V	
V+	Positive output supply voltage <sup>(2)</sup>	-0.3	7	V	
V-	Negative output supply voltage <sup>(2)</sup>	0.3	-7	V	
V+ - V-	Supply voltage difference <sup>(2)</sup>		13	V	
V <sub>I</sub>	Input voltage	DIN, $\overline{\text{FORCEOFF}}$ , FORCEON, $\overline{\text{EN}}$	-0.3	6	V
		RIN	-25	25	
V <sub>O</sub>	Output voltage	DOUT	-13.2	13.2	V
		ROUT, $\overline{\text{INVALID}}$	-0.3	V <sub>CC</sub> + 0.3	
T <sub>J</sub>	Operating virtual junction temperature		150	°C	
T <sub>stg</sub>	Storage temperature	-65	150	°C	

- (1) Stresses beyond those listed under *Absolute Maximum Ratings* may cause permanent damage to the device. These are stress ratings only, which do not imply functional operation of the device at these or any other conditions beyond those indicated under *Recommended Operating Conditions*. Exposure to absolute-maximum-rated conditions for extended periods may affect device reliability.
- (2) All voltages are with respect to network GND.

### 6.2 ESD Ratings

			VALUE	UNIT	
V <sub>(ESD)</sub>	Electrostatic discharge	Human-body model (HBM), per ANSI/ESDA/JEDEC JS-001 <sup>(1)</sup>	Pins 8 and 11	±15000	V
			All other pins	±2000	
		Charged-device model (CDM), per JEDEC specification JESD22-C101 <sup>(2)</sup>	All pins	±1500	
			IEC 61000-4-2 Contact Discharge, DOUT and RIN	±8000	
		IEC 61000-4-2 Air-Gap Discharge, DOUT and RIN	Pins 8 and 11	±15000	

- (1) JEDEC document JEP155 states that 500-V HBM allows safe manufacturing with a standard ESD control process.
- (2) JEDEC document JEP157 states that 250-V CDM allows safe manufacturing with a standard ESD control process.

### 6.3 Recommended Operating Conditions

See [Figure 11](#) <sup>(1)</sup>

		MIN	NOM	MAX	UNIT	
Supply voltage		V <sub>CC</sub> = 3.3 V	3	3.3	3.6	V
		V <sub>CC</sub> = 5 V	4.5	5	5.5	
V <sub>IH</sub>	Driver and control high-level input voltage	DIN, $\overline{\text{FORCEOFF}}$ , FORCEON, $\overline{\text{EN}}$	V <sub>CC</sub> = 3.3 V	2		V
			V <sub>CC</sub> = 5 V	2.4		
V <sub>IL</sub>	Driver and control low-level input voltage	DIN, $\overline{\text{FORCEOFF}}$ , FORCEON, $\overline{\text{EN}}$			0.8	V
V <sub>I</sub>	Driver and control input voltage	DIN, $\overline{\text{FORCEOFF}}$ , FORCEON	0		5.5	V
V <sub>I</sub>	Receiver input voltage		-25		25	V
T <sub>A</sub>	Operating free-air temperature	MAX3221EC	0		70	°C
		MAX3221EI	-40		85	

- (1) Test conditions are C1–C4 = 0.1 μF at V<sub>CC</sub> = 3.3 V ± 0.3 V; C1 = 0.047 μF, C2–C4 = 0.33 μF at V<sub>CC</sub> = 5 V ± 0.5 V.

## 6.4 Thermal Information

THERMAL METRIC <sup>(1)</sup>		MAX3221E		UNIT
		DB (SSOP)	PW (TSSOP)	
		16 PINS	16 PINS	
R <sub>θJA</sub>	Junction-to-ambient thermal resistance	92	100.3	°C/W
R <sub>θJC(top)</sub>	Junction-to-case (top) thermal resistance	42.8	35.6	°C/W
R <sub>θJB</sub>	Junction-to-board thermal resistance	42.4	45.1	°C/W
ψ <sub>JT</sub>	Junction-to-top characterization parameter	9.1	2.5	°C/W
ψ <sub>JB</sub>	Junction-to-board characterization parameter	41.9	44.6	°C/W

(1) For more information about traditional and new thermal metrics, see the [Semiconductor and IC Package Thermal Metrics](#) application report.

## 6.5 Electrical Characteristics

over recommended ranges of supply voltage and operating free-air temperature (unless otherwise noted)<sup>(1)</sup>

PARAMETER		TEST CONDITIONS		MIN	TYP <sup>(2)</sup>	MAX	UNIT
I <sub>I</sub>	Input leakage current	FORCEOFF, FORCEON, EN			±0.01	±1	μA
I <sub>CC</sub>	Supply current	Auto-power down disabled	No load, FORCEOFF and FORCEON at V <sub>CC</sub>		0.3	1	mA
		Powered off	No load, FORCEOFF at GND		1	10	μA
		Auto-power down enabled	No load, FORCEOFF at V <sub>CC</sub> , FORCEON at GND, All RIN are open or grounded		1	10	

(1) Test conditions are C1–C4 = 0.1 μF at V<sub>CC</sub> = 3.3 V ± 0.3 V; C1 = 0.047 μF, C2–C4 = 0.33 μF at V<sub>CC</sub> = 5 V ± 0.5 V.

(2) All typical values are at V<sub>CC</sub> = 3.3 V or V<sub>CC</sub> = 5 V, and T<sub>A</sub> = 25°C.

## 6.6 Electrical Characteristics: Driver

over recommended ranges of supply voltage and operating free-air temperature (unless otherwise noted)<sup>(1)</sup>

PARAMETER		TEST CONDITIONS		MIN	TYP <sup>(2)</sup>	MAX	UNIT
V <sub>OH</sub>	High-level output voltage	DOUT at R <sub>L</sub> = 3 kΩ to GND,	DIN = GND	5	5.4		V
V <sub>OL</sub>	Low-level output voltage	DOUT at R <sub>L</sub> = 3 kΩ to GND,	DIN = V <sub>CC</sub>	–5	–5.4		V
I <sub>IH</sub>	High-level input current	V <sub>I</sub> = V <sub>CC</sub>			±0.01	±1	μA
I <sub>IL</sub>	Low-level input current	V <sub>I</sub> = GND			±0.01	±1	μA
I <sub>OS</sub>	Short-circuit output current <sup>(3)</sup>	V <sub>CC</sub> = 3.6 V,	V <sub>O</sub> = 0 V		±35	±60	mA
		V <sub>CC</sub> = 5.5 V,	V <sub>O</sub> = 0 V		±35	±60	
r <sub>o</sub>	Output resistance	V <sub>CC</sub> , V+, and V– = 0 V,	V <sub>O</sub> = ±2 V	300	10M		Ω
I <sub>off</sub>	Output leakage current	FORCEOFF = GND	V <sub>O</sub> = ±12 V,	V <sub>CC</sub> = 3 V to 3.6 V		±25	μA
			V <sub>O</sub> = ±10 V,	V <sub>CC</sub> = 4.5 V to 5.5 V		±25	

(1) Test conditions are C1–C4 = 0.1 μF at V<sub>CC</sub> = 3.3 V ± 0.3 V; C1 = 0.047 μF, C2–C4 = 0.33 μF at V<sub>CC</sub> = 5 V ± 0.5 V.

(2) All typical values are at V<sub>CC</sub> = 3.3 V or V<sub>CC</sub> = 5 V, and T<sub>A</sub> = 25°C.

(3) Short-circuit durations should be controlled to prevent exceeding the device absolute power-dissipation ratings, and not more than one output should be shorted at a time.

## 6.7 Electrical Characteristics: Receiver

over recommended ranges of supply voltage and operating free-air temperature (unless otherwise noted)<sup>(1)</sup>

PARAMETER		TEST CONDITIONS	MIN	TYP <sup>(2)</sup>	MAX	UNIT
V <sub>OH</sub>	High-level output voltage	I <sub>OH</sub> = -1 mA	V <sub>CC</sub> - 0.6	V <sub>CC</sub> - 0.1		V
V <sub>OL</sub>	Low-level output voltage	I <sub>OL</sub> = 1.6 mA			0.4	V
V <sub>IT+</sub>	Positive-going input threshold voltage	V <sub>CC</sub> = 3.3 V		1.6	2.4	V
		V <sub>CC</sub> = 5 V		1.9	2.4	
V <sub>IT-</sub>	Negative-going input threshold voltage	V <sub>CC</sub> = 3.3 V	0.6	1.1		V
		V <sub>CC</sub> = 5 V	0.8	1.4		
V <sub>hys</sub>	Input hysteresis (V <sub>IT+</sub> - V <sub>IT-</sub> )			0.5		V
I <sub>off</sub>	Output leakage current	$\overline{\text{EN}} = V_{\text{CC}}$		±0.05	±10	µA
r <sub>i</sub>	Input resistance	V <sub>I</sub> = ±3 V to ±25 V	3	5	7	kΩ

(1) Test conditions are C1–C4 = 0.1 µF at V<sub>CC</sub> = 3.3 V ± 0.3 V; C1 = 0.047 µF, C2–C4 = 0.33 µF at V<sub>CC</sub> = 5 V ± 0.5 V.

(2) All typical values are at V<sub>CC</sub> = 3.3 V or V<sub>CC</sub> = 5 V, and T<sub>A</sub> = 25°C.

## 6.8 Electrical Characteristics: Auto-Power Down

over recommended ranges of supply voltage and operating free-air temperature (unless otherwise noted)

PARAMETER		TEST CONDITIONS	MIN	MAX	UNIT
V <sub>T+(valid)</sub>	Receiver input threshold for $\overline{\text{INVALID}}$ high-level output voltage	FORCEON = GND, $\overline{\text{FORCEOFF}} = V_{\text{CC}}$		2.7	V
V <sub>T-(valid)</sub>	Receiver input threshold for $\overline{\text{INVALID}}$ high-level output voltage	FORCEON = GND, $\overline{\text{FORCEOFF}} = V_{\text{CC}}$	-2.7		V
V <sub>T(invalid)</sub>	Receiver input threshold for $\overline{\text{INVALID}}$ low-level output voltage	FORCEON = GND, $\overline{\text{FORCEOFF}} = V_{\text{CC}}$	-0.3	0.3	V
V <sub>OH</sub>	$\overline{\text{INVALID}}$ high-level output voltage	I <sub>OH</sub> = -1 mA, FORCEON = GND, $\overline{\text{FORCEOFF}} = V_{\text{CC}}$	V <sub>CC</sub> - 0.6		V
V <sub>OL</sub>	$\overline{\text{INVALID}}$ low-level output voltage	I <sub>OL</sub> = 1.6 mA, FORCEON = GND, $\overline{\text{FORCEOFF}} = V_{\text{CC}}$		0.4	V

## 6.9 Switching Characteristics: Driver

over recommended ranges of supply voltage and operating free-air temperature (unless otherwise noted)<sup>(1)</sup>

PARAMETER	TEST CONDITIONS		MIN	TYP <sup>(2)</sup>	MAX	UNIT
Maximum data rate	C <sub>L</sub> = 1000 pF,	R <sub>L</sub> = 3 kΩ,	150	250		kbit/s
t <sub>sk(p)</sub>	C <sub>L</sub> = 150 pF to 2500 pF,	R <sub>L</sub> = 3 kΩ to 7 kΩ, See <a href="#">Figure 6</a>		100		ns
SR(tr)	Slew rate, transition region (see <a href="#">Figure 5</a> )	V <sub>CC</sub> = 3.3 V, R <sub>L</sub> = 3 kΩ to 7 kΩ	C <sub>L</sub> = 150 pF to 1000 pF	6	30	V/µs
			C <sub>L</sub> = 150 pF to 2500 pF	4	30	

(1) Test conditions are C1–C4 = 0.1 µF at V<sub>CC</sub> = 3.3 V ± 0.3 V; C1 = 0.047 µF, C2–C4 = 0.33 µF at V<sub>CC</sub> = 5 V ± 0.5 V.

(2) All typical values are at V<sub>CC</sub> = 3.3 V or V<sub>CC</sub> = 5 V, and T<sub>A</sub> = 25°C.

(3) Pulse skew is defined as |t<sub>PLH</sub> - t<sub>PHL</sub>| of each channel of the same device.

## 6.10 Switching Characteristics: Receiver

over recommended ranges of supply voltage and operating free-air temperature (unless otherwise noted)<sup>(1)</sup>

PARAMETER		TEST CONDITIONS	TYP <sup>(2)</sup>	UNIT
t <sub>PLH</sub>	Propagation delay time, low- to high-level output	C <sub>L</sub> = 150 pF, See <a href="#">Figure 7</a>	150	ns
t <sub>PHL</sub>	Propagation delay time, high- to low-level output	C <sub>L</sub> = 150 pF, See <a href="#">Figure 7</a>	150	ns
t <sub>en</sub>	Output enable time	C <sub>L</sub> = 150 pF, R <sub>L</sub> = 3 kΩ, See <a href="#">Figure 8</a>	200	ns
t <sub>dis</sub>	Output disable time	C <sub>L</sub> = 150 pF, R <sub>L</sub> = 3 kΩ, See <a href="#">Figure 8</a>	200	ns
t <sub>sk(p)</sub>	Pulse skew <sup>(3)</sup>	See <a href="#">Figure 7</a>	50	ns

(1) Test conditions are C1–C4 = 0.1 µF at V<sub>CC</sub> = 3.3 V ± 0.3 V; C1 = 0.047 µF, C2–C4 = 0.33 µF at V<sub>CC</sub> = 5 V ± 0.5 V.

(2) All typical values are at V<sub>CC</sub> = 3.3 V or V<sub>CC</sub> = 5 V, and T<sub>A</sub> = 25°C.

(3) Pulse skew is defined as |t<sub>PLH</sub> - t<sub>PHL</sub>| of each channel of the same device.

### 6.11 Switching Characteristics: Auto-Power Down

over recommended ranges of supply voltage and operating free-air temperature (unless otherwise noted)

PARAMETER		TYP <sup>(1)</sup>	UNIT
t <sub>valid</sub>	Propagation delay time, low- to high-level output	1	μs
t <sub>invalid</sub>	Propagation delay time, high- to low-level output	30	μs
t <sub>en</sub>	Supply enable time	100	μs

(1) All typical values are at V<sub>CC</sub> = 3.3 V or V<sub>CC</sub> = 5 V, and T<sub>A</sub> = 25°C.

### 6.12 Typical Characteristics

T<sub>A</sub> = 25° C; V<sub>CC</sub> = 3.3V

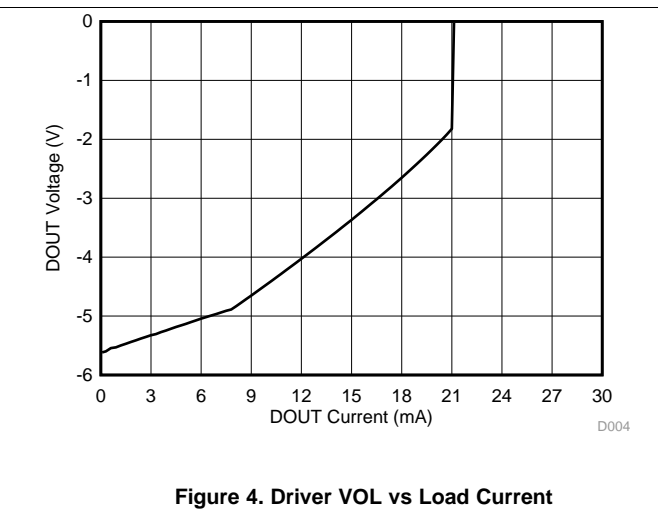
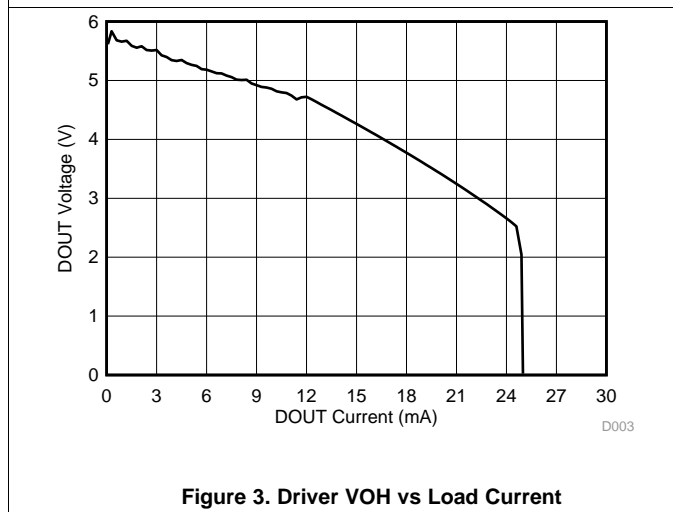
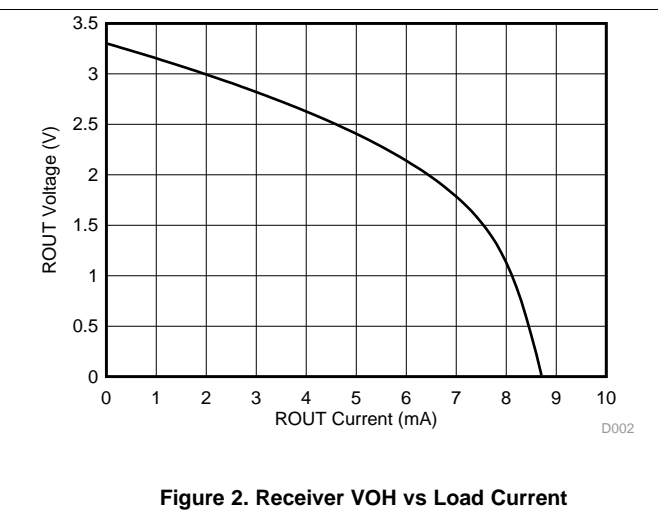
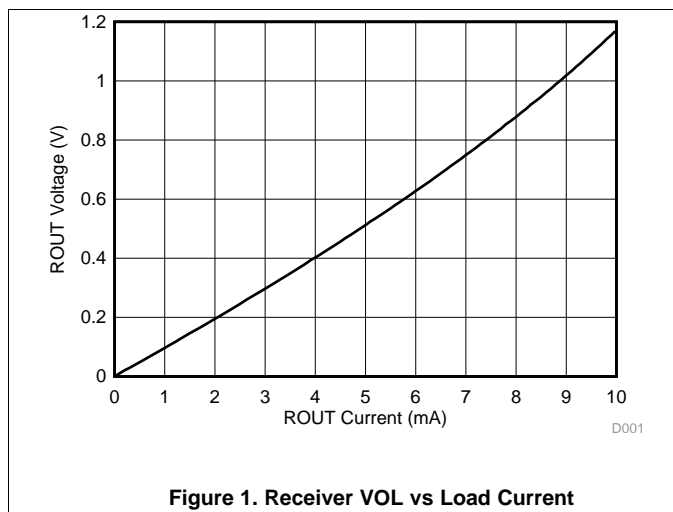

## 7 Parameter Measurement Information

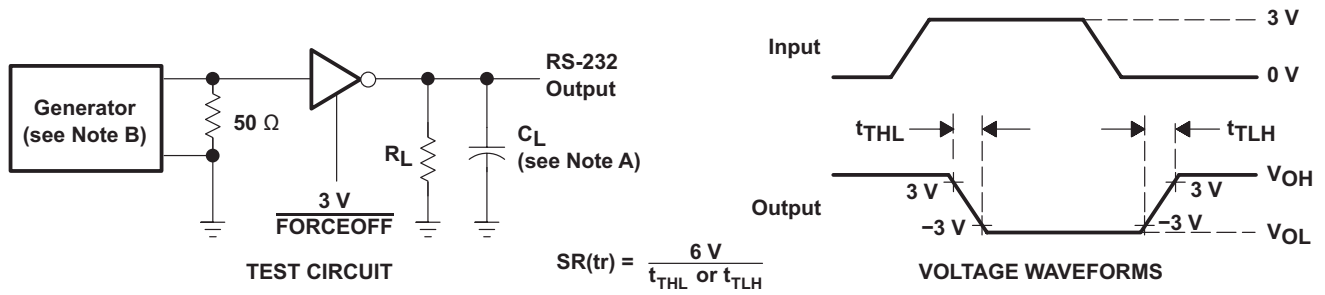

- A.  $C_L$  includes probe and jig capacitance.
- B. The pulse generator has the following characteristics: PRR = 250 kbps,  $Z_O = 50\ \Omega$ , 50% duty cycle,  $t_r \leq 10\text{ ns}$ ,  $t_f \leq 10\text{ ns}$ .

Figure 5. Driver Slew Rate

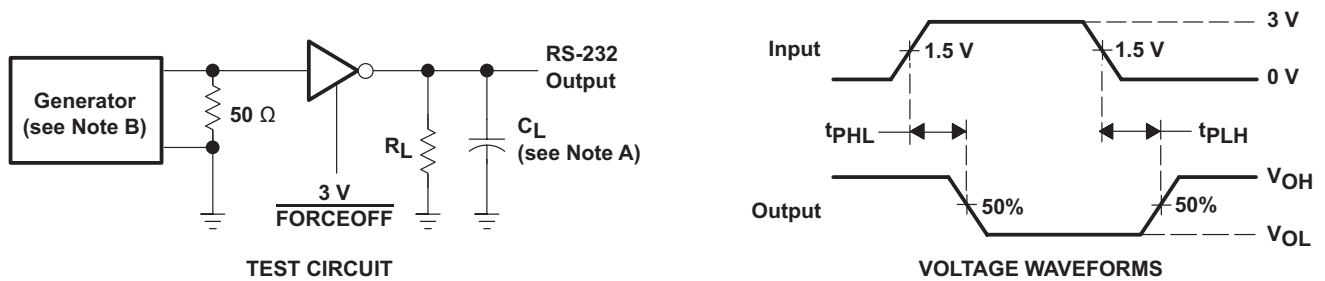

- A.  $C_L$  includes probe and jig capacitance.
- B. The pulse generator has the following characteristics: PRR = 250 kbps,  $Z_O = 50\ \Omega$ , 50% duty cycle,  $t_r \leq 10\text{ ns}$ ,  $t_f \leq 10\text{ ns}$ .

Figure 6. Driver Pulse Skew

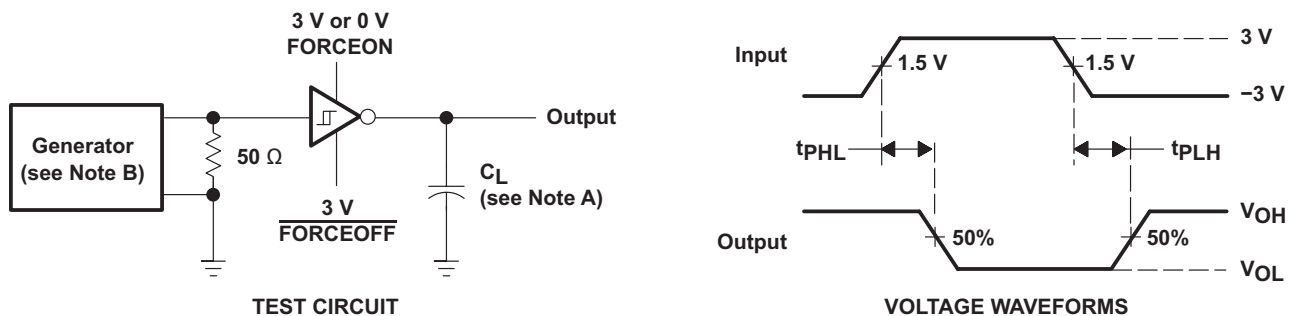

- A.  $C_L$  includes probe and jig capacitance.
- B. The pulse generator has the following characteristics:  $Z_O = 50\ \Omega$ , 50% duty cycle,  $t_r \leq 10\text{ ns}$ ,  $t_f \leq 10\text{ ns}$ .

Figure 7. Receiver Propagation Delay Times

Parameter Measurement Information (continued)

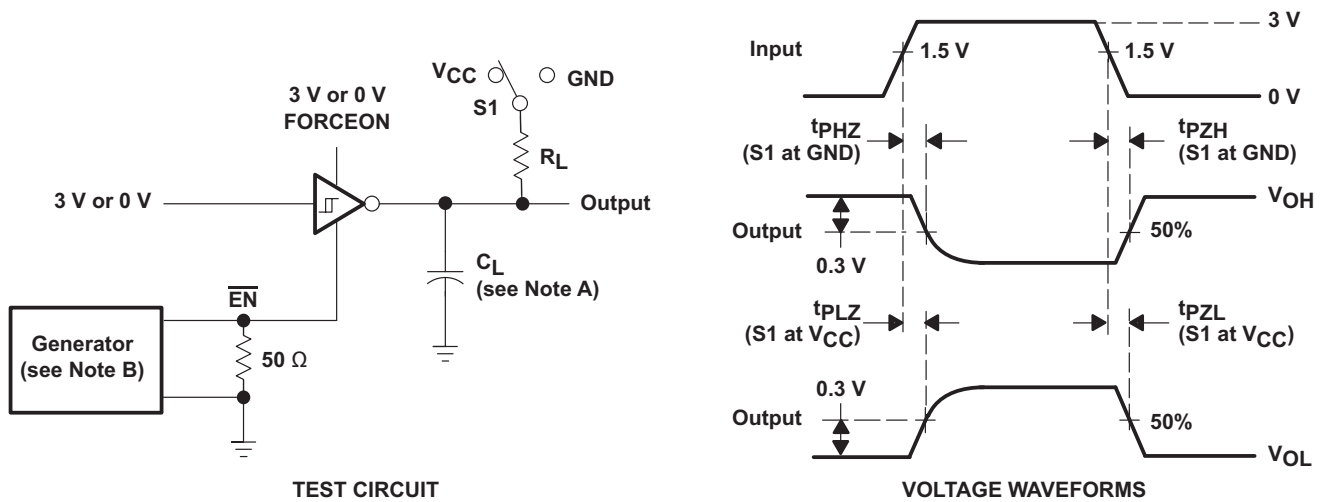

- A.  $C_L$  includes probe and jig capacitance.
- B. The pulse generator has the following characteristics:  $Z_O = 50 \Omega$ , 50% duty cycle,  $t_r \leq 10 \text{ ns}$ ,  $t_f \leq 10 \text{ ns}$ .
- C.  $t_{PLZ}$  and  $t_{PHZ}$  are the same as  $t_{dis}$ .
- D.  $t_{PZL}$  and  $t_{PZH}$  are the same as  $t_{en}$ .

Figure 8. Receiver Enable and Disable Times

Parameter Measurement Information (continued)

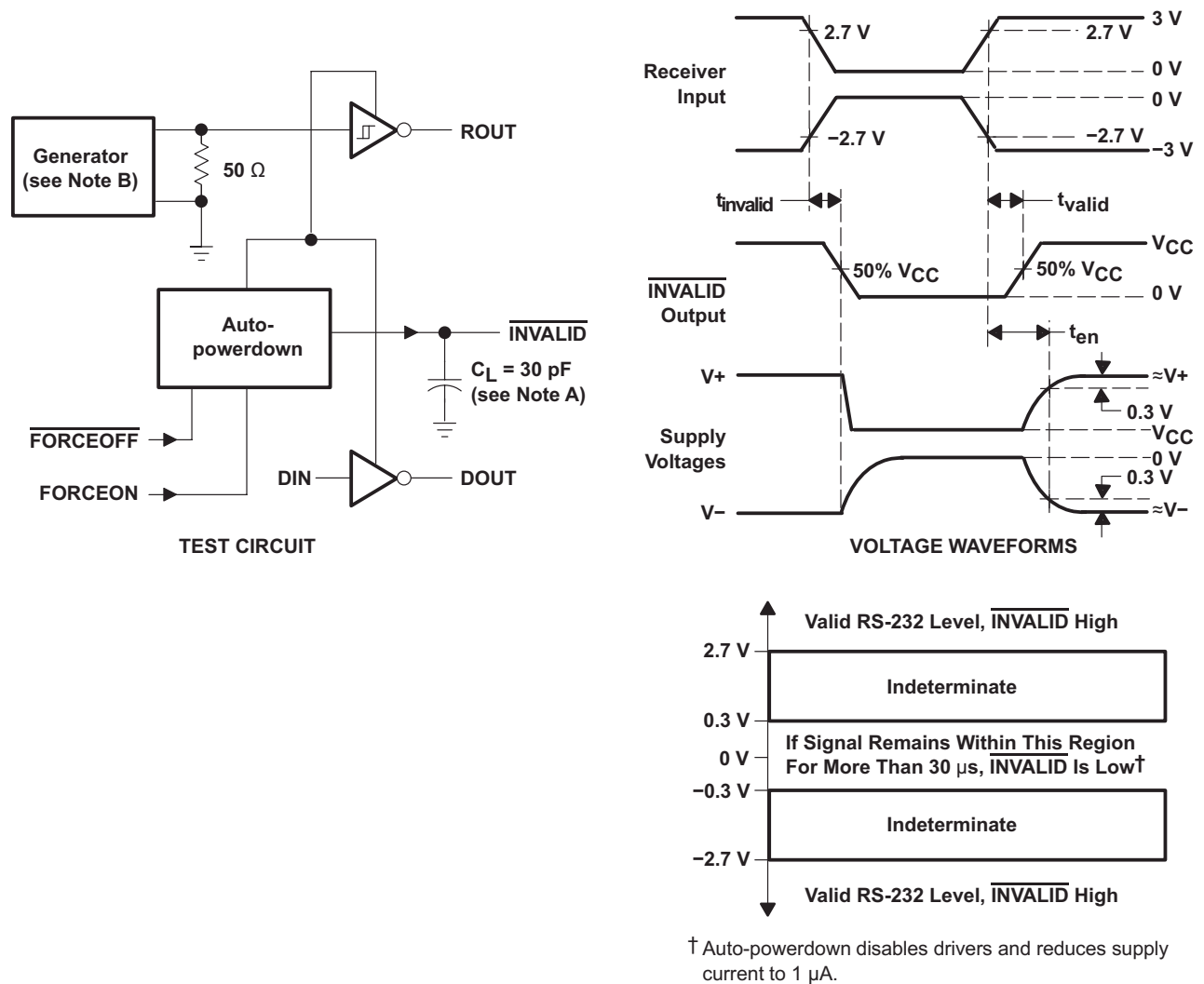

Figure 9.  $\overline{\text{INVALID}}$  Propagation Delay Times and Driver Enabling Time

## 8 Detailed Description

### 8.1 Overview

The MAX3221E is a single driver, single receiver RS-232 solution operating from a single  $V_{CC}$  supply. The RS-232 pins provide IEC 61000-4-2 ESD protection. The device meets the requirements of TIA/EIA-232-F and provides the electrical interface between an asynchronous communication controller and the serial-port connector. The charge pump and four small external capacitors allow operation from a single 3-V to 5.5-V supply. These devices operate at data signaling rates up to 250 kbit/s and a maximum of 30-V/ $\mu$ s driver output slew rate.

Flexible control options for power management are available when the serial port is inactive. The auto-power-down feature functions when FORCEON is low and FORCEOFF is high. During this mode of operation, if the device does not sense a valid RS-232 signal on the receiver input, the driver output is disabled. If FORCEOFF is set low and EN is high, both the driver and receiver are shut off, and the supply current is reduced to 1  $\mu$ A. Disconnecting the serial port or turning off the peripheral drivers causes the auto-power-down condition to occur. Auto-power down can be disabled when FORCEON and FORCEOFF are high. With auto-power down enabled, the device is activated automatically when a valid signal is applied to the receiver input. The INVALID output notifies the user if an RS-232 signal is present at the receiver input. INVALID is high (valid data) if the receiver input voltage is greater than 2.7 V or less than -2.7 V, or has been between -0.3 V and 0.3 V for less than 30  $\mu$ s. INVALID is low (invalid data) if the receiver input voltage is between -0.3 V and 0.3 V for more than 30  $\mu$ s. See Figure 5 for receiver input levels.

### 8.2 Functional Block Diagram

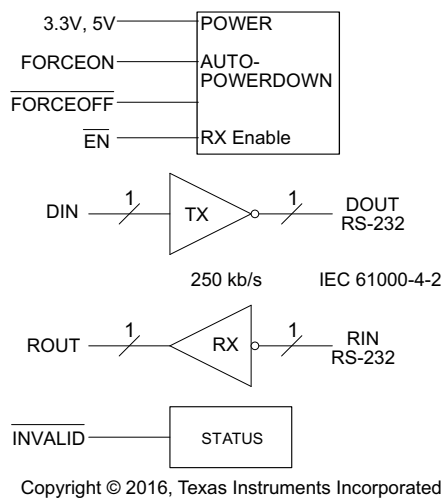

Figure 10. Logic Diagram (Positive Logic)

### 8.3 Feature Description

#### 8.3.1 Power

The power block increases, inverts, and regulates voltage at V+ and V- pins using a charge pump that requires four external capacitors. Auto-power-down feature for driver is controlled by FORCEON and FORCEOFF inputs. Receiver is controlled by EN input. When MAX3221E is unpowered, it can be safely connected to an active remote RS-232 device.

#### 8.3.2 RS-232 Driver

One driver interfaces standard logic levels to RS-232 levels. DIN input must be valid high or low.

## Feature Description (continued)

### 8.3.3 RS-232 Receiver

One receiver interfaces RS-232 levels to standard logic levels. An open input results in a high output on ROUT. RIN input includes an internal standard RS-232 load. A logic high input on the  $\overline{\text{EN}}$  pin shuts down the receiver output.

### 8.3.4 RS-232 Status

The  $\overline{\text{INVALID}}$  output goes low when RIN input is unpowered for more than 30  $\mu\text{s}$ . The  $\overline{\text{INVALID}}$  output goes high when receiver has a valid input. The  $\overline{\text{INVALID}}$  output is active when  $V_{\text{CC}}$  is powered irregardless of FORCEON and FORCEOFF inputs (see Table 3).

## 8.4 Device Functional Modes

Table 1, Table 2, and Table 3 show the behavior of the driver, receiver, and  $\overline{\text{INVALID}}$  features under all possible relevant combinations of inputs.

**Table 1. Function Tables Each Driver<sup>(1)</sup>**

INPUTS				OUTPUT DOUT	DRIVER STATUS
DIN	FORCEON	$\overline{\text{FORCEOFF}}$	VALID RIN RS-232 LEVEL		
X	X	L	X	Z	Powered off
L	H	H	X	H	Normal operation with auto-power down disabled
H	H	H	X	L	
L	L	H	Yes	H	Normal operation with auto-power down enabled
H	L	H	Yes	L	
L	L	H	No	Z	Powered off by auto-power down feature
H	L	H	No	Z	

(1) H = high level, L = low level, X = irrelevant, Z = high impedance

**Table 2. Each Receiver<sup>(1)</sup>**

INPUTS			OUTPUT ROUT
RIN	$\overline{\text{EN}}$	VALID RIN RS-232 LEVEL	
L	L	X	H
H	L	X	L
X	H	X	Z
Open	L	No	H

(1) H = high level, L = low level, X = irrelevant, Z = high impedance (off), Open = disconnected input or connected driver off

**Table 3.  $\overline{\text{INVALID}}$ <sup>(1)</sup>**

INPUTS				OUTPUT $\overline{\text{INVALID}}$
RIN	FORCEON	$\overline{\text{FORCEOFF}}$	$\overline{\text{EN}}$	
L	X	X	X	H
H	X	X	X	H
Open	X	X	X	L

(1) H = high level, L = low level, X = irrelevant, Z = high impedance (off), Open = input disconnected or connected driver off

## 9 Application and Implementation

---

### NOTE

Information in the following applications sections is not part of the TI component specification, and TI does not warrant its accuracy or completeness. TI's customers are responsible for determining suitability of components for their purposes. Customers should validate and test their design implementation to confirm system functionality.

---

### 9.1 Application Information

The MAX3221E line driver and receiver is a specialized device for 3-V to 5.5-V RS-232 communication applications. This application is a generic implementation of this device with all required external components. For proper operation, add capacitors as shown in [Figure 11](#).

### 9.2 Typical Application

ROUT and DIN connect to UART or general purpose logic lines. FORCEON and  $\overline{\text{FORCEOFF}}$  may be connected general purpose logic lines or tied to ground or  $V_{CC}$ . INVALID may be connected to a general purpose logic line or left unconnected. RIN and DOUT lines connect to a RS-232 connector or cable. DIN, FORCEON, and  $\overline{\text{FORCEOFF}}$  inputs must not be left unconnected.

Typical Application (continued)

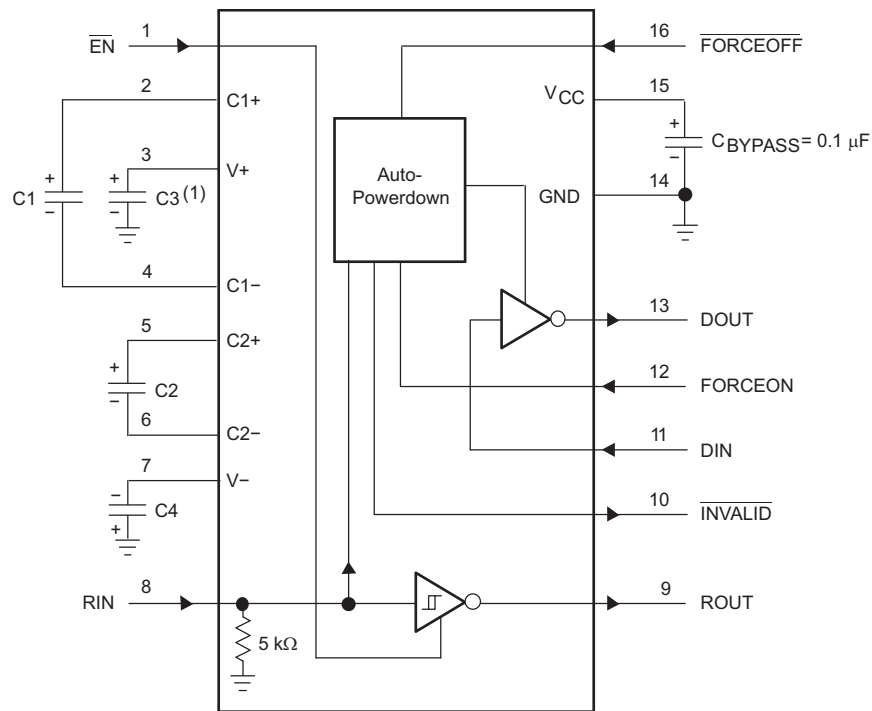

(1) C3 can be connected to V<sub>CC</sub> or GND.

NOTES: A. Resistor values shown are nominal.

B. Nonpolarized ceramic capacitors are acceptable. If polarized tantalum or electrolytic capacitors are used, they should be connected as shown.

V<sub>CC</sub> vs CAPACITOR VALUES

V <sub>CC</sub>	C1	C2, C3, and C4
3.3 V ± 0.3 V	0.1 μF	0.1 μF
5 V ± 0.5 V	0.047 μF	0.33 μF
3 V to 5.5 V	0.1 μF	0.47 μF

Copyright © 2016, Texas Instruments Incorporated

Figure 11. Typical Operating Circuit and Capacitor Values

9.2.1 Design Requirements

- Recommended V<sub>CC</sub> is 3.3 V or 5 V.
  - 3 V to 5.5 V is also possible
- Maximum recommended bit rate is 250 kbps.
- Use capacitors as shown in [Figure 11](#).

9.2.2 Detailed Design Procedure

- DIN,  $\overline{\text{FORCEOFF}}$  and FORCEON inputs must be connected to valid low or high logic levels.
- Select capacitor values based on V<sub>CC</sub> level for best performance.

Typical Application (continued)

9.2.3 Application Curves

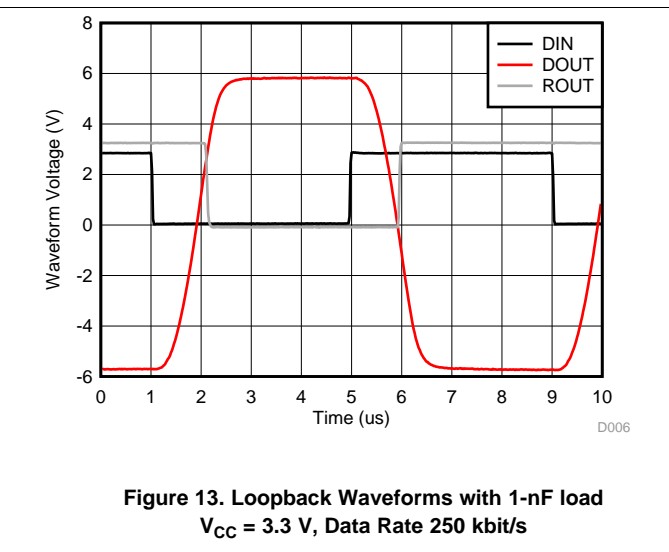
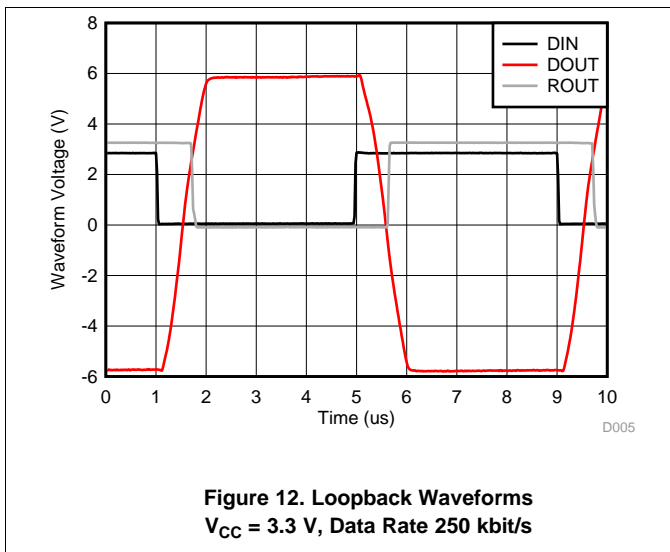

## 10 Power Supply Recommendations

TI recommends a 0.1- $\mu\text{F}$  capacitor to filter noise on the power supply pin. For additional filter capability, a 0.01- $\mu\text{F}$  capacitor may be added in parallel as well. Power supply input voltage is recommended to be any valid level in [Recommended Operating Conditions](#).

## 11 Layout

### 11.1 Layout Guidelines

Keep the external capacitor traces short. This is more important on C1 and C2 nodes that have the fastest rise and fall times. Make the impedance from MAX3221E ground pin and circuit board's ground plane as low as possible for best ESD performance. Use wide metal and multiple vias on both sides of ground pin.

### 11.2 Layout Example

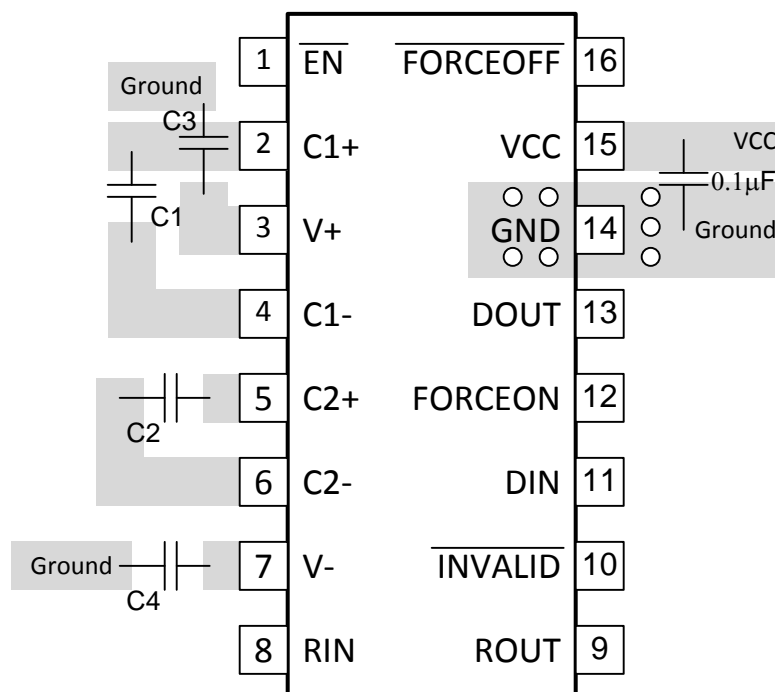

**Figure 14. MAX3221E Layout Example**

## 12 Device and Documentation Support

### 12.1 Receiving Notification of Documentation Updates

To receive notification of documentation updates, navigate to the device product folder on ti.com. In the upper right corner, click on *Alert me* to register and receive a weekly digest of any product information that has changed. For change details, review the revision history included in any revised document.

### 12.2 Community Resource

The following links connect to TI community resources. Linked contents are provided "AS IS" by the respective contributors. They do not constitute TI specifications and do not necessarily reflect TI's views; see TI's [Terms of Use](#).

**TI E2E™ Online Community** *TI's Engineer-to-Engineer (E2E) Community*. Created to foster collaboration among engineers. At e2e.ti.com, you can ask questions, share knowledge, explore ideas and help solve problems with fellow engineers.

**Design Support** *TI's Design Support* Quickly find helpful E2E forums along with design support tools and contact information for technical support.

### 12.3 Trademarks

E2E is a trademark of Texas Instruments.  
All other trademarks are the property of their respective owners.

### 12.4 Electrostatic Discharge Caution



These devices have limited built-in ESD protection. The leads should be shorted together or the device placed in conductive foam during storage or handling to prevent electrostatic damage to the MOS gates.

### 12.5 Glossary

[SLYZ022](#) — *TI Glossary*.

This glossary lists and explains terms, acronyms, and definitions.

## 13 Mechanical, Packaging, and Orderable Information

The following pages include mechanical, packaging, and orderable information. This information is the most current data available for the designated devices. This data is subject to change without notice and revision of this document. For browser-based versions of this data sheet, refer to the left-hand navigation.

**PACKAGING INFORMATION**

Orderable Device	Status (1)	Package Type	Package Drawing	Pins	Package Qty	Eco Plan (2)	Lead/Ball Finish (6)	MSL Peak Temp (3)	Op Temp (°C)	Device Marking (4/5)	Samples
MAX3221ECDB	ACTIVE	SSOP	DB	16	80	Green (RoHS & no Sb/Br)	CU NIPDAU	Level-1-260C-UNLIM	0 to 70	MP221EC	<a href="#">Samples</a>
MAX3221ECDBR	ACTIVE	SSOP	DB	16	2000	Green (RoHS & no Sb/Br)	CU NIPDAU	Level-1-260C-UNLIM	0 to 70	MP221EC	<a href="#">Samples</a>
MAX3221ECDBRG4	ACTIVE	SSOP	DB	16	2000	Green (RoHS & no Sb/Br)	CU NIPDAU	Level-1-260C-UNLIM	0 to 70	MP221EC	<a href="#">Samples</a>
MAX3221ECPW	ACTIVE	TSSOP	PW	16	90	Green (RoHS & no Sb/Br)	CU NIPDAU	Level-1-260C-UNLIM	0 to 70	MP221EC	<a href="#">Samples</a>
MAX3221ECPWE4	ACTIVE	TSSOP	PW	16	90	Green (RoHS & no Sb/Br)	CU NIPDAU	Level-1-260C-UNLIM	0 to 70	MP221EC	<a href="#">Samples</a>
MAX3221ECPWG4	ACTIVE	TSSOP	PW	16	90	Green (RoHS & no Sb/Br)	CU NIPDAU	Level-1-260C-UNLIM	0 to 70	MP221EC	<a href="#">Samples</a>
MAX3221ECPWR	ACTIVE	TSSOP	PW	16	2000	Green (RoHS & no Sb/Br)	CU NIPDAU	Level-1-260C-UNLIM	0 to 70	MP221EC	<a href="#">Samples</a>
MAX3221EIDB	ACTIVE	SSOP	DB	16	80	Green (RoHS & no Sb/Br)	CU NIPDAU	Level-1-260C-UNLIM	-40 to 85	MP221EI	<a href="#">Samples</a>
MAX3221EIDBG4	ACTIVE	SSOP	DB	16	80	Green (RoHS & no Sb/Br)	CU NIPDAU	Level-1-260C-UNLIM	-40 to 85	MP221EI	<a href="#">Samples</a>
MAX3221EIDBR	ACTIVE	SSOP	DB	16	2000	Green (RoHS & no Sb/Br)	CU NIPDAU	Level-1-260C-UNLIM	-40 to 85	MP221EI	<a href="#">Samples</a>
MAX3221EIDBRG4	ACTIVE	SSOP	DB	16	2000	Green (RoHS & no Sb/Br)	CU NIPDAU	Level-1-260C-UNLIM	-40 to 85	MP221EI	<a href="#">Samples</a>
MAX3221EIPW	ACTIVE	TSSOP	PW	16	90	Green (RoHS & no Sb/Br)	CU NIPDAU	Level-1-260C-UNLIM	-40 to 85	MP221EI	<a href="#">Samples</a>
MAX3221EIPWE4	ACTIVE	TSSOP	PW	16	90	Green (RoHS & no Sb/Br)	CU NIPDAU	Level-1-260C-UNLIM	-40 to 85	MP221EI	<a href="#">Samples</a>
MAX3221EIPWG4	ACTIVE	TSSOP	PW	16	90	Green (RoHS & no Sb/Br)	CU NIPDAU	Level-1-260C-UNLIM	-40 to 85	MP221EI	<a href="#">Samples</a>
MAX3221EIPWR	ACTIVE	TSSOP	PW	16	2000	Green (RoHS & no Sb/Br)	CU NIPDAU   CU SN	Level-1-260C-UNLIM	-40 to 85	MP221EI	<a href="#">Samples</a>
MAX3221EIPWRG4	ACTIVE	TSSOP	PW	16	2000	Green (RoHS & no Sb/Br)	CU NIPDAU	Level-1-260C-UNLIM	-40 to 85	MP221EI	<a href="#">Samples</a>

(1) The marketing status values are defined as follows:  
**ACTIVE:** Product device recommended for new designs.

---

**LIFEBUY:** TI has announced that the device will be discontinued, and a lifetime-buy period is in effect.

**NRND:** Not recommended for new designs. Device is in production to support existing customers, but TI does not recommend using this part in a new design.

**PREVIEW:** Device has been announced but is not in production. Samples may or may not be available.

**OBSELETE:** TI has discontinued the production of the device.

<sup>(2)</sup> **RoHS:** TI defines "RoHS" to mean semiconductor products that are compliant with the current EU RoHS requirements for all 10 RoHS substances, including the requirement that RoHS substance do not exceed 0.1% by weight in homogeneous materials. Where designed to be soldered at high temperatures, "RoHS" products are suitable for use in specified lead-free processes. TI may reference these types of products as "Pb-Free".

**RoHS Exempt:** TI defines "RoHS Exempt" to mean products that contain lead but are compliant with EU RoHS pursuant to a specific EU RoHS exemption.

**Green:** TI defines "Green" to mean the content of Chlorine (Cl) and Bromine (Br) based flame retardants meet JS709B low halogen requirements of  $\leq 1000$ ppm threshold. Antimony trioxide based flame retardants must also meet the  $\leq 1000$ ppm threshold requirement.

<sup>(3)</sup> MSL, Peak Temp. - The Moisture Sensitivity Level rating according to the JEDEC industry standard classifications, and peak solder temperature.

<sup>(4)</sup> There may be additional marking, which relates to the logo, the lot trace code information, or the environmental category on the device.

<sup>(5)</sup> Multiple Device Markings will be inside parentheses. Only one Device Marking contained in parentheses and separated by a "~" will appear on a device. If a line is indented then it is a continuation of the previous line and the two combined represent the entire Device Marking for that device.

<sup>(6)</sup> Lead/Ball Finish - Orderable Devices may have multiple material finish options. Finish options are separated by a vertical ruled line. Lead/Ball Finish values may wrap to two lines if the finish value exceeds the maximum column width.

**Important Information and Disclaimer:** The information provided on this page represents TI's knowledge and belief as of the date that it is provided. TI bases its knowledge and belief on information provided by third parties, and makes no representation or warranty as to the accuracy of such information. Efforts are underway to better integrate information from third parties. TI has taken and continues to take reasonable steps to provide representative and accurate information but may not have conducted destructive testing or chemical analysis on incoming materials and chemicals. TI and TI suppliers consider certain information to be proprietary, and thus CAS numbers and other limited information may not be available for release.

In no event shall TI's liability arising out of such information exceed the total purchase price of the TI part(s) at issue in this document sold by TI to Customer on an annual basis.

**TAPE AND REEL INFORMATION**

**QUADRANT ASSIGNMENTS FOR PIN 1 ORIENTATION IN TAPE**

\*All dimensions are nominal

Device	Package Type	Package Drawing	Pins	SPQ	Reel Diameter (mm)	Reel Width W1 (mm)	A0 (mm)	B0 (mm)	K0 (mm)	P1 (mm)	W (mm)	Pin1 Quadrant
MAX3221ECPWR	TSSOP	PW	16	2000	330.0	12.4	6.9	5.6	1.6	8.0	12.0	Q1
MAX3221EIPWR	TSSOP	PW	16	2000	330.0	12.4	6.9	5.6	1.6	8.0	12.0	Q1
MAX3221EIPWR	TSSOP	PW	16	2000	330.0	12.4	6.9	5.6	1.6	8.0	12.0	Q1
MAX3221EIPWRG4	TSSOP	PW	16	2000	330.0	12.4	6.9	5.6	1.6	8.0	12.0	Q1

**TAPE AND REEL BOX DIMENSIONS**

\*All dimensions are nominal

Device	Package Type	Package Drawing	Pins	SPQ	Length (mm)	Width (mm)	Height (mm)
MAX3221ECPWR	TSSOP	PW	16	2000	367.0	367.0	35.0
MAX3221EIPWR	TSSOP	PW	16	2000	367.0	367.0	35.0
MAX3221EIPWR	TSSOP	PW	16	2000	364.0	364.0	27.0
MAX3221EIPWRG4	TSSOP	PW	16	2000	367.0	367.0	35.0





# EXAMPLE BOARD LAYOUT

PW0016A

TSSOP - 1.2 mm max height

SMALL OUTLINE PACKAGE



LAND PATTERN EXAMPLE  
EXPOSED METAL SHOWN  
SCALE: 10X

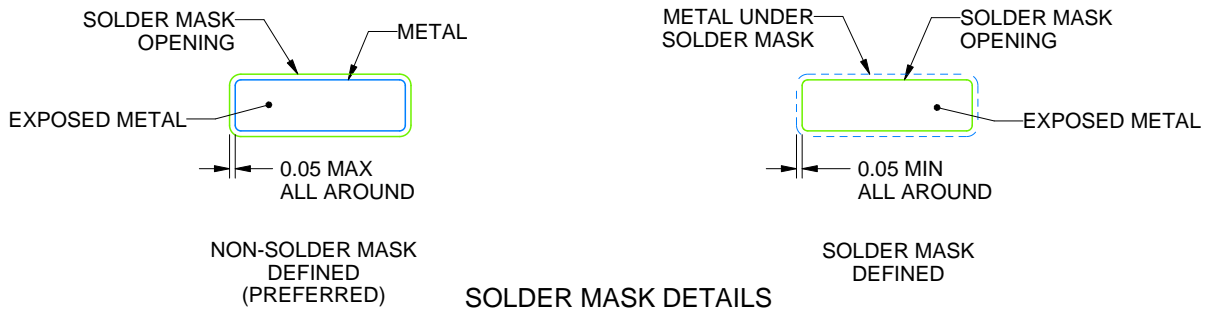

SOLDER MASK DETAILS

4220204/A 02/2017

NOTES: (continued)

- 6. Publication IPC-7351 may have alternate designs.
- 7. Solder mask tolerances between and around signal pads can vary based on board fabrication site.

# EXAMPLE STENCIL DESIGN

PW0016A

TSSOP - 1.2 mm max height

SMALL OUTLINE PACKAGE



SOLDER PASTE EXAMPLE  
BASED ON 0.125 mm THICK STENCIL  
SCALE: 10X

4220204/A 02/2017

NOTES: (continued)

8. Laser cutting apertures with trapezoidal walls and rounded corners may offer better paste release. IPC-7525 may have alternate design recommendations.
9. Board assembly site may have different recommendations for stencil design.

## IMPORTANT NOTICE AND DISCLAIMER

TI PROVIDES TECHNICAL AND RELIABILITY DATA (INCLUDING DATASHEETS), DESIGN RESOURCES (INCLUDING REFERENCE DESIGNS), APPLICATION OR OTHER DESIGN ADVICE, WEB TOOLS, SAFETY INFORMATION, AND OTHER RESOURCES "AS IS" AND WITH ALL FAULTS, AND DISCLAIMS ALL WARRANTIES, EXPRESS AND IMPLIED, INCLUDING WITHOUT LIMITATION ANY IMPLIED WARRANTIES OF MERCHANTABILITY, FITNESS FOR A PARTICULAR PURPOSE OR NON-INFRINGEMENT OF THIRD PARTY INTELLECTUAL PROPERTY RIGHTS.

These resources are intended for skilled developers designing with TI products. You are solely responsible for (1) selecting the appropriate TI products for your application, (2) designing, validating and testing your application, and (3) ensuring your application meets applicable standards, and any other safety, security, or other requirements. These resources are subject to change without notice. TI grants you permission to use these resources only for development of an application that uses the TI products described in the resource. Other reproduction and display of these resources is prohibited. No license is granted to any other TI intellectual property right or to any third party intellectual property right. TI disclaims responsibility for, and you will fully indemnify TI and its representatives against, any claims, damages, costs, losses, and liabilities arising out of your use of these resources.

TI's products are provided subject to TI's Terms of Sale ([www.ti.com/legal/termsofsale.html](http://www.ti.com/legal/termsofsale.html)) or other applicable terms available either on [ti.com](http://ti.com) or provided in conjunction with such TI products. TI's provision of these resources does not expand or otherwise alter TI's applicable warranties or warranty disclaimers for TI products.

Mailing Address: Texas Instruments, Post Office Box 655303, Dallas, Texas 75265  
Copyright © 2019, Texas Instruments Incorporated

## Looking for pricing, stock, or lifecycle information?

Click below to explore more details on WIN SOURCE:

 [View MAX3221EIDBRG4 on WIN SOURCE](#)

 [Texas Instruments](#) Information

## Optimize Your Supply Chain with WIN SOURCE Solutions

-  Global Sourcing Solution
-  Obsolete Management
-  Cost Control Management
-  Shortage Management
-  Alternative Solution
-  Excess Inventory Management