



THE DATASHEET OF DBB03AIPMR



FEATURES

- **Low Supply Voltage Range: 1.8 V to 3.6 V**
- **Ultralow-Power Consumption:**
 - Active Mode: 160 μ A at 1 MHz, 2.2 V
 - Standby Mode: 0.9 μ A
 - Off Mode (RAM Retention) : 0.1 μ A
- **Contains Frequency-Hopping Firmware for Dolphin Reference Design**
- **Firmware Resides in ROM-Based Program Memory and is Fixed**
- **Simple UART Interface to an External Host/System Microcontroller**
- **Pre-Defined Protocol for Communication with an External Host/System Microcontroller**
- **Five Power-Saving Modes**
- **Wake-Up From Standby Mode in less than 6 μ s**
- **16-Bit RISC Architecture, 125-ns Instruction Cycle Time**
- **Serial Communication Interface (USART), Software Selects Asynchronous UART or Synchronous SPI**
- **Available in 64-Pin Quad Flat Pack (QFP)**
- **For Complete Dolphin Product Description, See the *Dolphin Frequency Hopping Spread Spectrum Evaluation Kit Hardware and Software User's Guide (SLLU090)***

DESCRIPTION

The DBB03A is a baseband ASIC for the "Dolphin" reference design. The firmware for the Dolphin reference design resides in the ROM-based program memory of the DBB03A, and thus can be readily interfaced with a TRF6903 single-chip RF Transceiver to generate a frequency hopping wireless UART "Dolphin" reference design chipset. This is illustrated in [Figure 1](#).

The DBB03A baseband ASIC in addition to being a RF baseband processor is also responsible for communications with an external host/system microcontroller. In a typical end user application, the Dolphin chipset will be connected up to an external host/system microcontroller that will send configuration messages, RF transmission messages into the Dolphin chipset, or receive status, RF messages received from the Dolphin chipset.

Any catalog low-cost host/system microcontroller can be interfaced to the Dolphin chipset as long as the Dolphin host interface protocol for communication is adhered to. (See Application Note Dolphin - Frequency Hopping Spread Spectrum Chipset Host Interface Protocol TI Literature SWRA043) Texas Instruments recommends its ultra-low power MSP430 series of microcontrollers to interface with Dolphin.

The interface between the DBB03A baseband ASIC and an external host/system microcontroller is a simple UART consisting of RX and TX data lines. (See Application Note *Interfacing Dolphin to an External System Microcontroller*, TI Literature SWRA045).



Please be aware that an important notice concerning availability, standard warranty, and use in critical applications of Texas Instruments semiconductor products and disclaimers thereto appears at the end of this data sheet.

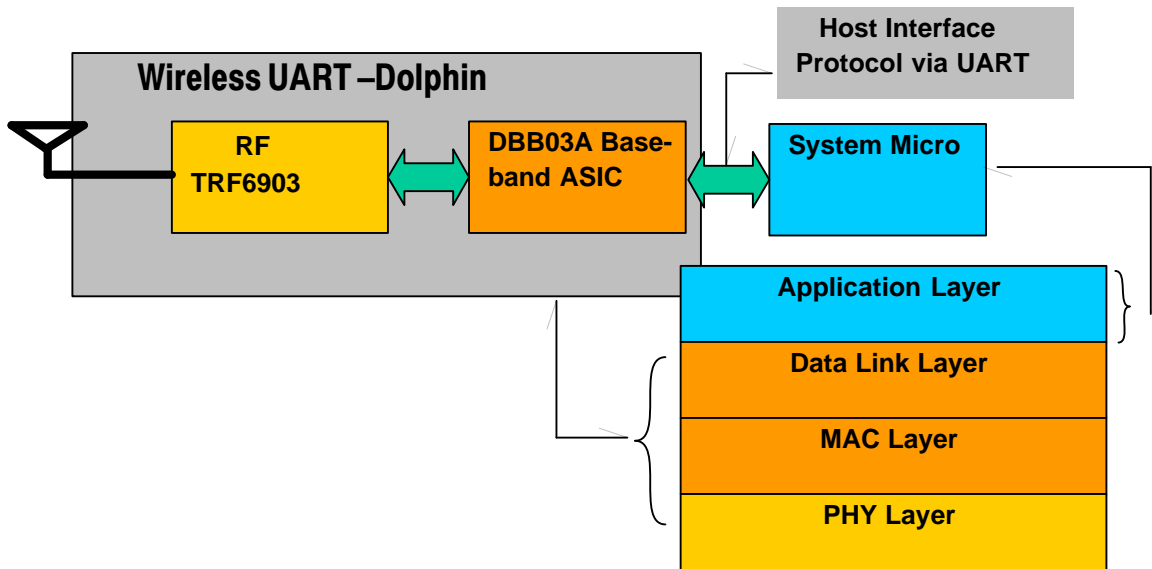

Figure 1. DBB03A - Baseband ASIC for the Dolphin Chipset

The Wireless UART Dolphin chipset is a true Data-In/RF-out and RF-in/Data-out solution with all aspects of data management and frequency hopping implemented in firmware residing on the DBB03A. As illustrated in [Figure 1](#), the DBB03A baseband ASIC contains the complete firmware for Dolphin (PHYSical, MAC and the Data Link layer), while the application layer protocol is handled by the external Host/System Microcontroller.

AVAILABLE OPTIONS

T_A	PACKAGE	ORDER NUMBER
-40°C to 85°C	Plastic 64-pin QFP (PM)	DBB03A IPM

PIN DESIGNATION, DBB03A Baseband ASIC

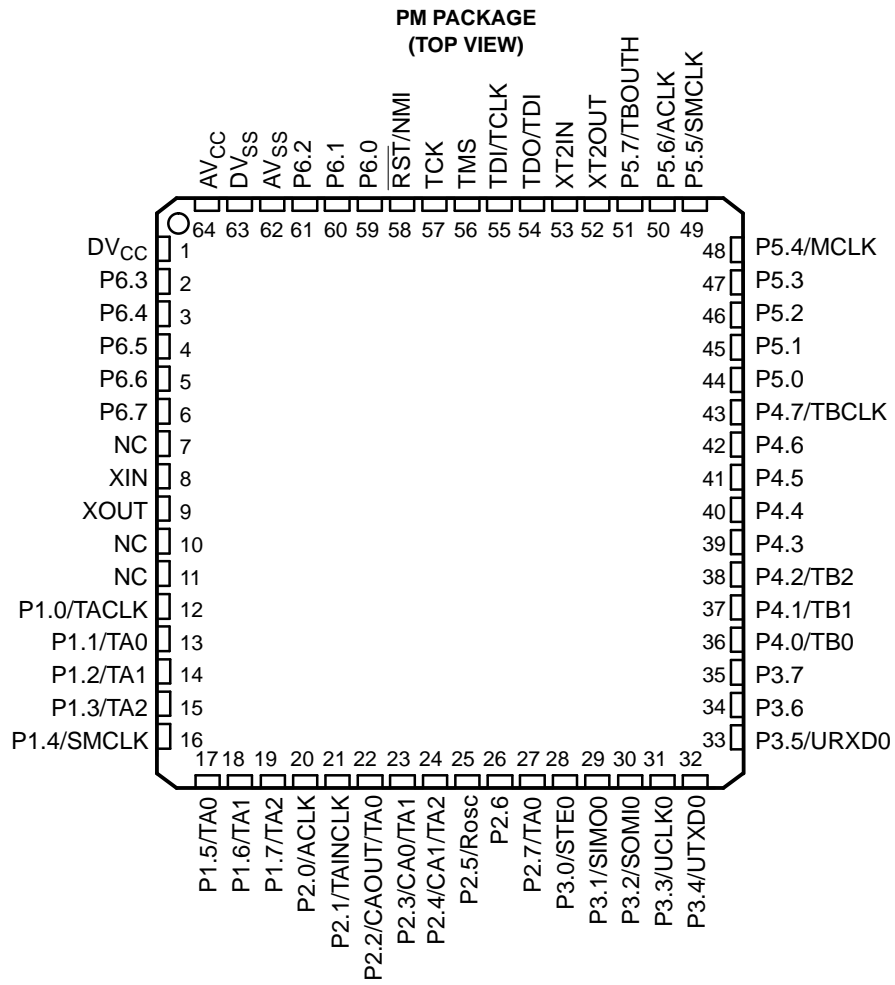

NC – No internal connection

FUNCTIONAL BLOCK DIAGRAMS: DBB03A

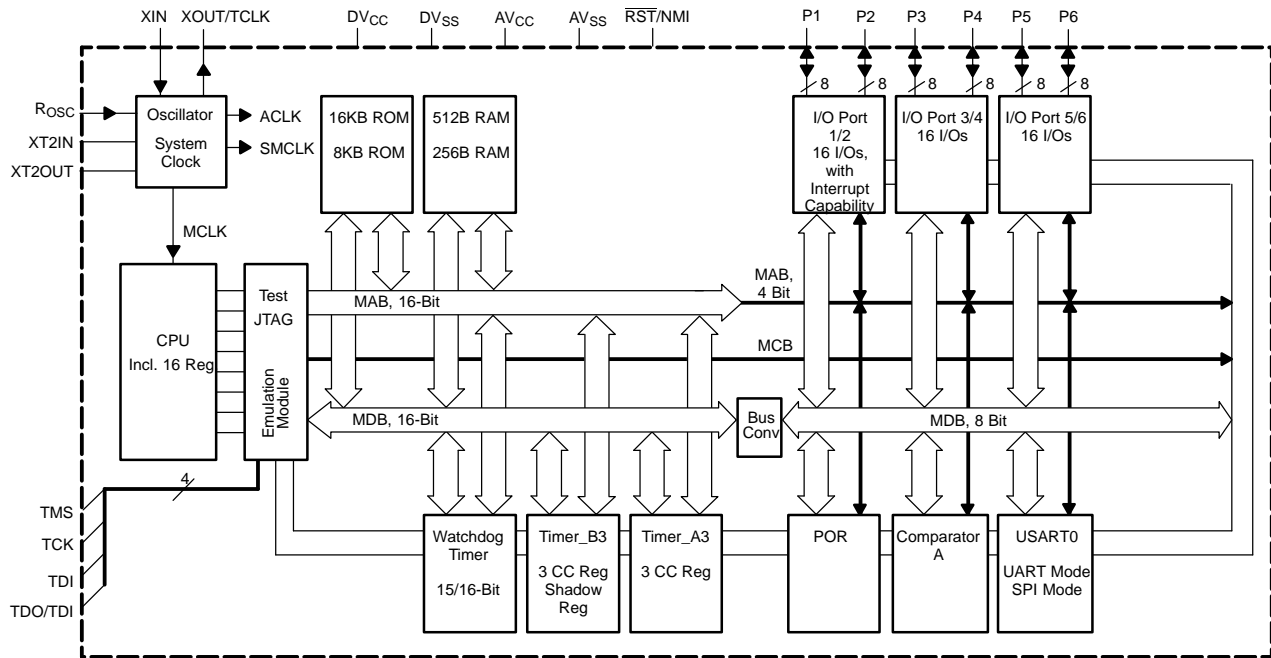

DEVICE INFORMATION

TERMINAL FUNCTIONS

TERMINAL		I/O	DESCRIPTION
NAME	NO.		
AV _{CC}	64		Supply voltage, positive terminal. AV _{CC} and DV _{CC} are internally connected together.
AV _{SS}	64		Supply voltage, negative terminal. AV _{SS} and DV _{SS} are internally connected together.
DV _{CC}	1		Supply voltage, positive terminal. AV _{CC} and DV _{CC} are internally connected together.
DV _{SS}	63		Supply voltage, negative terminal. AV _{SS} and DV _{SS} are internally connected together.
P1.0/TACLK	12	I/O	General-purpose digital I/O pin/Timer_A, clock signal TACLK input
P1.1/TA0	13	I/O	General-purpose digital I/O pin/Timer_A, capture: CCI0A input, compare: Out0 output
P1.2/TA1	14	I/O	General-purpose digital I/O pin/Timer_A, capture: CCI1A input, compare: Out1 output
P1.3/TA2	15	I/O	General-purpose digital I/O pin/Timer_A, capture: CCI2A input, compare: Out2 output
P1.4/SMCLK	16	I/O	General-purpose digital I/O pin/SMCLK signal output
P1.5/TA0	17	I/O	General-purpose digital I/O pin/Timer_A, compare: Out0 output
P1.6/TA1	18	I/O	General-purpose digital I/O pin/Timer_A, compare: Out1 output
P1.7/TA2	19	I/O	General-purpose digital I/O pin/Timer_A, compare: Out2 output
P2.0/ACLK	20	I/O	General-purpose digital I/O pin/ACLK output
P2.1/TAINCLK	21	I/O	General-purpose digital I/O pin/Timer_A, clock signal at INCLK
P2.2/CAOUT/TA0	22	I/O	General-purpose digital I/O pin/Timer_A, capture: CCI0B input/Comparator_A output
P2.3/CA0/TA1	23	I/O	General-purpose digital I/O pin/Timer_A, compare: Out1 output/Comparator_A input
P2.4/CA1/TA2	24	I/O	General-purpose digital I/O pin/Timer_A, compare: Out2 output/Comparator_A input
P2.5/R _{Osc}	25	I/O	General-purpose digital I/O pin/input for external resistor defining the DCO nominal frequency
P2.6	26	I/O	General-purpose digital I/O pin

DEVICE INFORMATION (continued)
TERMINAL FUNCTIONS (continued)

TERMINAL		I/O	DESCRIPTION
NAME	NO.		
P2.7/TA0	27	I/O	General-purpose digital I/O pin/Timer_A, compare: Out0 output
P3.0/STE0	28	I/O	General-purpose digital I/O pin/slave transmit enable - USART0/SPI mode
P3.1/SIMO0	29	I/O	General-purpose digital I/O pin/slave in/master out of USART0/SPI mode
P3.2/SOMI0	30	I/O	General-purpose digital I/O pin/slave out/master in of USART0/SPI mode
P3.3/UCLK0	31	I/O	General-purpose digital I/O pin/external clock input - USART0/UART or SPI mode, clock output - USART0/SPI mode
P3.4/UTXD0	32	I/O	General-purpose digital I/O pin/transmit data out - USART0/UART mode
P3.5/URXD0	33	I/O	General-purpose digital I/O pin/receive data in - USART0/UART mode
P3.6	34	I/O	General-purpose digital I/O pin
P3.7	35	I/O	General-purpose digital I/O pin
P4.0/TB0	36	I/O	General-purpose digital I/O pin/Timer_B, capture: CCI0A/B input, compare: Out0 output
P4.1/TB1	37	I/O	General-purpose digital I/O pin/Timer_B, capture: CCI1A/B input, compare: Out1 output
P4.2/TB2	38	I/O	General-purpose digital I/O pin/Timer_B, capture: CCI2A/B input, compare: Out2 output
P4.3	39	I/O	General-purpose digital I/O pin
P4.4	40	I/O	General-purpose digital I/O pin
P4.5	41	I/O	General-purpose digital I/O pin
P4.6	42	I/O	General-purpose digital I/O pin
P4.7/TBCLK	43	I/O	General-purpose digital I/O pin/Timer_B, clock signal TBCLK input
P5.0	44	I/O	General-purpose digital I/O pin
P5.1	45	I/O	General-purpose digital I/O pin
P5.2	46	I/O	General-purpose digital I/O pin
P5.3	47	I/O	General-purpose digital I/O pin
P5.4/MCLK	48	I/O	General-purpose digital I/O pin/main system clock MCLK output
P5.5/SMCLK	49	I/O	General-purpose digital I/O pin/submain system clock SMCLK output
P5.6/ACLK	50	I/O	General-purpose digital I/O pin/auxiliary clock ACLK output
P5.7/TBOUT H	51	I/O	General-purpose digital I/O pin/switch all PWM digital output ports to high impedance - Timer_B7 TB0 to TB2
P6.0	59	I/O	General-purpose digital I/O pin
P6.1	60	I/O	General-purpose digital I/O pin
P6.2	61	I/O	General-purpose digital I/O pin
P6.3	2	I/O	General-purpose digital I/O pin
P6.4	3	I/O	General-purpose digital I/O pin
P6.5	4	I/O	General-purpose digital I/O pin
P6.6	5	I/O	General-purpose digital I/O pin
P6.7	6	I/O	General-purpose digital I/O pin
RST/NMI	58	I	Reset input, nonmaskable interrupt input port
TCK	57	I	Test clock. TCK is the clock input port for device programming test.
TDI/TCLK	55	I	Test data input or test clock input. TDI is used as a data input port. The device protection fuse is connected to TDI.
TDO/TDI	54	I/O	Test data output port. TDO/TDI data output
TMS	56	I	Test mode select. TMS is used as an input port for device test.
NC	7, 10, 11		No internal connection
XIN	8	I	Input port for crystal oscillator XT1. Standard or watch crystals can be connected.
XOUT	9	O	Output terminal of crystal oscillator XT1
XT2IN	53	I	Input port for crystal oscillator XT2. Only standard crystals can be connected.
XT2OUT	52	O	Output terminal of crystal oscillator XT2

PACKAGING INFORMATION

Orderable Device	Status ⁽¹⁾	Package Type	Package Drawing	Pins	Package Qty	Eco Plan ⁽²⁾	Lead/Ball Finish	MSL Peak Temp ⁽³⁾
DBB03AIPM	NRND	LQFP	PM	64		Green (RoHS & no Sb/Br)	CU NIPDAU	Level-3-260C-168 HR
DBB03AIPMR	NRND	LQFP	PM	64		Green (RoHS & no Sb/Br)	CU NIPDAU	Level-3-260C-168 HR

⁽¹⁾ The marketing status values are defined as follows:

ACTIVE: Product device recommended for new designs.

LIFEBUY: TI has announced that the device will be discontinued, and a lifetime-buy period is in effect.

NRND: Not recommended for new designs. Device is in production to support existing customers, but TI does not recommend using this part in a new design.

PREVIEW: Device has been announced but is not in production. Samples may or may not be available.

OBsolete: TI has discontinued the production of the device.

⁽²⁾ Eco Plan - The planned eco-friendly classification: Pb-Free (RoHS), Pb-Free (RoHS Exempt), or Green (RoHS & no Sb/Br) - please check <http://www.ti.com/productcontent> for the latest availability information and additional product content details.

TBD: The Pb-Free/Green conversion plan has not been defined.

Pb-Free (RoHS): TI's terms "Lead-Free" or "Pb-Free" mean semiconductor products that are compatible with the current RoHS requirements for all 6 substances, including the requirement that lead not exceed 0.1% by weight in homogeneous materials. Where designed to be soldered at high temperatures, TI Pb-Free products are suitable for use in specified lead-free processes.

Pb-Free (RoHS Exempt): This component has a RoHS exemption for either 1) lead-based flip-chip solder bumps used between the die and package, or 2) lead-based die adhesive used between the die and leadframe. The component is otherwise considered Pb-Free (RoHS compatible) as defined above.

Green (RoHS & no Sb/Br): TI defines "Green" to mean Pb-Free (RoHS compatible), and free of Bromine (Br) and Antimony (Sb) based flame retardants (Br or Sb do not exceed 0.1% by weight in homogeneous material)

⁽³⁾ MSL, Peak Temp. -- The Moisture Sensitivity Level rating according to the JEDEC industry standard classifications, and peak solder temperature.

Important Information and Disclaimer:The information provided on this page represents TI's knowledge and belief as of the date that it is provided. TI bases its knowledge and belief on information provided by third parties, and makes no representation or warranty as to the accuracy of such information. Efforts are underway to better integrate information from third parties. TI has taken and continues to take reasonable steps to provide representative and accurate information but may not have conducted destructive testing or chemical analysis on incoming materials and chemicals. TI and TI suppliers consider certain information to be proprietary, and thus CAS numbers and other limited information may not be available for release.

In no event shall TI's liability arising out of such information exceed the total purchase price of the TI part(s) at issue in this document sold by TI to Customer on an annual basis.

PM (S-PQFP-G64)

PLASTIC QUAD FLATPACK

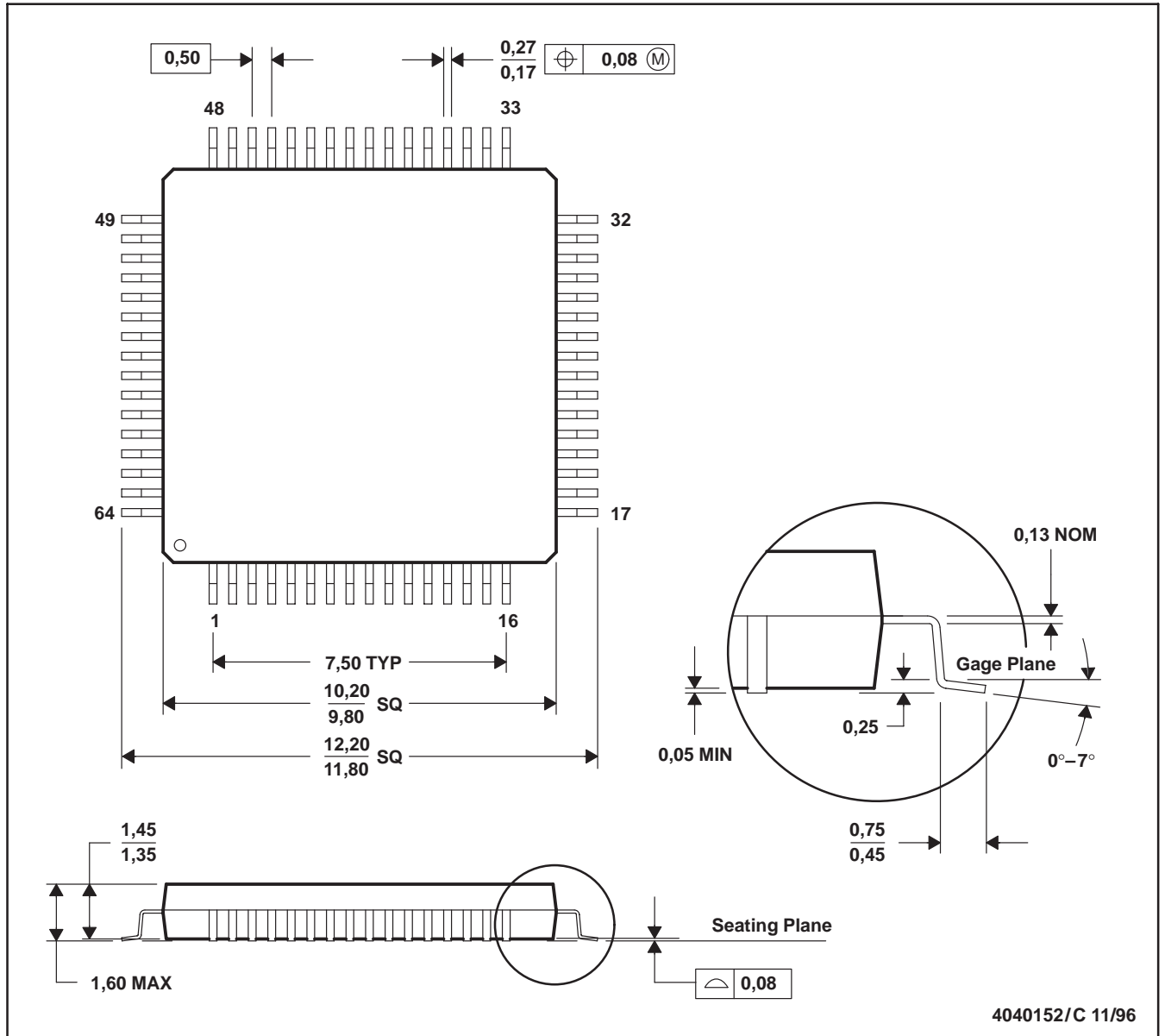

- NOTES:
- A. All linear dimensions are in millimeters.
 - B. This drawing is subject to change without notice.
 - C. Falls within JEDEC MS-026
 - D. May also be thermally enhanced plastic with leads connected to the die pads.

IMPORTANT NOTICE

Texas Instruments Incorporated and its subsidiaries (TI) reserve the right to make corrections, modifications, enhancements, improvements, and other changes to its products and services at any time and to discontinue any product or service without notice. Customers should obtain the latest relevant information before placing orders and should verify that such information is current and complete. All products are sold subject to TI's terms and conditions of sale supplied at the time of order acknowledgment.

TI warrants performance of its hardware products to the specifications applicable at the time of sale in accordance with TI's standard warranty. Testing and other quality control techniques are used to the extent TI deems necessary to support this warranty. Except where mandated by government requirements, testing of all parameters of each product is not necessarily performed.

TI assumes no liability for applications assistance or customer product design. Customers are responsible for their products and applications using TI components. To minimize the risks associated with customer products and applications, customers should provide adequate design and operating safeguards.

TI does not warrant or represent that any license, either express or implied, is granted under any TI patent right, copyright, mask work right, or other TI intellectual property right relating to any combination, machine, or process in which TI products or services are used. Information published by TI regarding third-party products or services does not constitute a license from TI to use such products or services or a warranty or endorsement thereof. Use of such information may require a license from a third party under the patents or other intellectual property of the third party, or a license from TI under the patents or other intellectual property of TI.

Reproduction of TI information in TI data books or data sheets is permissible only if reproduction is without alteration and is accompanied by all associated warranties, conditions, limitations, and notices. Reproduction of this information with alteration is an unfair and deceptive business practice. TI is not responsible or liable for such altered documentation. Information of third parties may be subject to additional restrictions.

Resale of TI products or services with statements different from or beyond the parameters stated by TI for that product or service voids all express and any implied warranties for the associated TI product or service and is an unfair and deceptive business practice. TI is not responsible or liable for any such statements.

TI products are not authorized for use in safety-critical applications (such as life support) where a failure of the TI product would reasonably be expected to cause severe personal injury or death, unless officers of the parties have executed an agreement specifically governing such use. Buyers represent that they have all necessary expertise in the safety and regulatory ramifications of their applications, and acknowledge and agree that they are solely responsible for all legal, regulatory and safety-related requirements concerning their products and any use of TI products in such safety-critical applications, notwithstanding any applications-related information or support that may be provided by TI. Further, Buyers must fully indemnify TI and its representatives against any damages arising out of the use of TI products in such safety-critical applications.

TI products are neither designed nor intended for use in military/aerospace applications or environments unless the TI products are specifically designated by TI as military-grade or "enhanced plastic." Only products designated by TI as military-grade meet military specifications. Buyers acknowledge and agree that any such use of TI products which TI has not designated as military-grade is solely at the Buyer's risk, and that they are solely responsible for compliance with all legal and regulatory requirements in connection with such use.

TI products are neither designed nor intended for use in automotive applications or environments unless the specific TI products are designated by TI as compliant with ISO/TS 16949 requirements. Buyers acknowledge and agree that, if they use any non-designated products in automotive applications, TI will not be responsible for any failure to meet such requirements.

Following are URLs where you can obtain information on other Texas Instruments products and application solutions:

Products

Amplifiers	amplifier.ti.com
Data Converters	dataconverter.ti.com
DSP	dsp.ti.com
Clocks and Timers	www.ti.com/clocks
Interface	interface.ti.com
Logic	logic.ti.com
Power Mgmt	power.ti.com
Microcontrollers	microcontroller.ti.com
RFID	www.ti-rfid.com
RF/IF and ZigBee® Solutions	www.ti.com/lprf

Applications

Audio	www.ti.com/audio
Automotive	www.ti.com/automotive
Broadband	www.ti.com/broadband
Digital Control	www.ti.com/digitalcontrol
Medical	www.ti.com/medical
Military	www.ti.com/military
Optical Networking	www.ti.com/opticalnetwork
Security	www.ti.com/security
Telephony	www.ti.com/telephony
Video & Imaging	www.ti.com/video
Wireless	www.ti.com/wireless

Mailing Address: Texas Instruments, Post Office Box 655303, Dallas, Texas 75265
Copyright © 2008, Texas Instruments Incorporated

Looking for pricing, stock, or lifecycle information?

Click below to explore more details on WIN SOURCE:

 [View DBB03AIPMR on WIN SOURCE](#)

 [Texas Instruments](#) Information

Optimize Your Supply Chain with WIN SOURCE Solutions

-  Global Sourcing Solution
-  Obsolete Management
-  Cost Control Management
-  Shortage Management
-  Alternative Solution
-  Excess Inventory Management