



**THE DATASHEET OF  
SN74BCT760N**



# SN54BCT760, SN74BCT760 OCTAL BUFFERS/DRIVERS WITH OPEN-COLLECTOR OUTPUTS

SCBS034B – JULY 1989 – REVISED NOVEMBER 1993

- Open-Collector Version of 'BCT244
- Open-Collector Outputs Drive Bus Lines or Buffer Memory Address Registers
- ESD Protection Exceeds 2000 V Per MIL-STD-883C Method 3015
- Packages Options Include Plastic Small-Outline (DW) Packages, Ceramic Chip Carriers (FK) and Flatpacks (W), and Standard Plastic and Ceramic 300-mil DIPs (J, N)

## description

These octal buffers and line drivers are designed specifically to improve both the performance and density of 3-state memory address drivers, clock drivers, and bus-oriented receivers and transmitters.

The 'BCT760 is organized as two 4-bit buffers/line drivers with separate output-enable ( $\overline{OE}$ ) inputs. When  $\overline{OE}$  is low, the device passes data from the A inputs to the Y outputs. When  $\overline{OE}$  is high, the outputs are in the high-impedance state.

The SN54BCT760 is characterized for operation over the full military temperature range of  $-55^{\circ}\text{C}$  to  $125^{\circ}\text{C}$ . The SN74BCT760 is characterized for operation from  $0^{\circ}\text{C}$  to  $70^{\circ}\text{C}$ .

SN54BCT760 . . . J OR W PACKAGE  
SN74BCT760 . . . DW OR N PACKAGE  
(TOP VIEW)

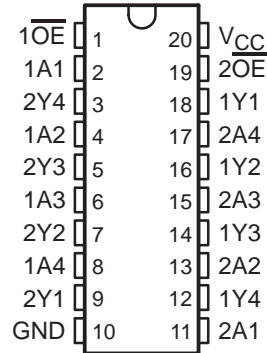

SN54BCT760 . . . FK PACKAGE  
(TOP VIEW)

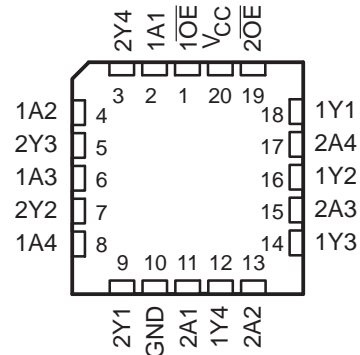

FUNCTION TABLE  
(each buffer)

| INPUTS          |   | OUTPUT |
|-----------------|---|--------|
| $\overline{OE}$ | A | Y      |
| L               | H | H      |
| L               | L | L      |
| H               | X | H      |

# SN54BCT760, SN74BCT760 OCTAL BUFFERS/DRIVERS WITH OPEN-COLLECTOR OUTPUTS

SCBS034B – JULY 1989 – REVISED NOVEMBER 1993

## logic symbol†

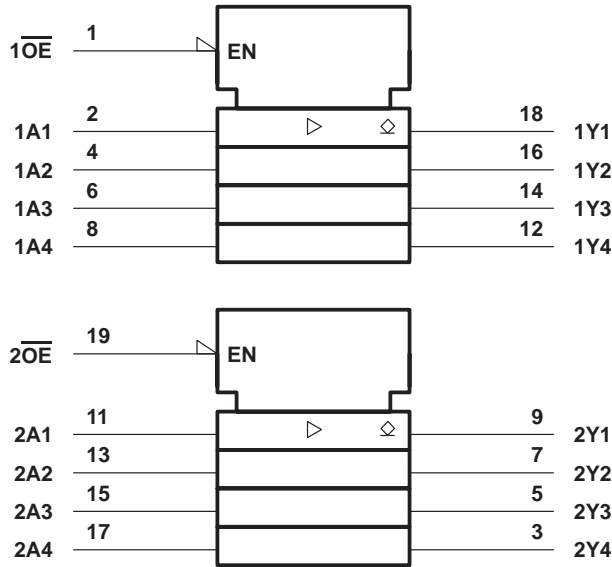

† This symbol is in accordance with ANSI/IEEE Std 91-1984 and IEC Publication 617-12.

## logic diagram (positive logic)

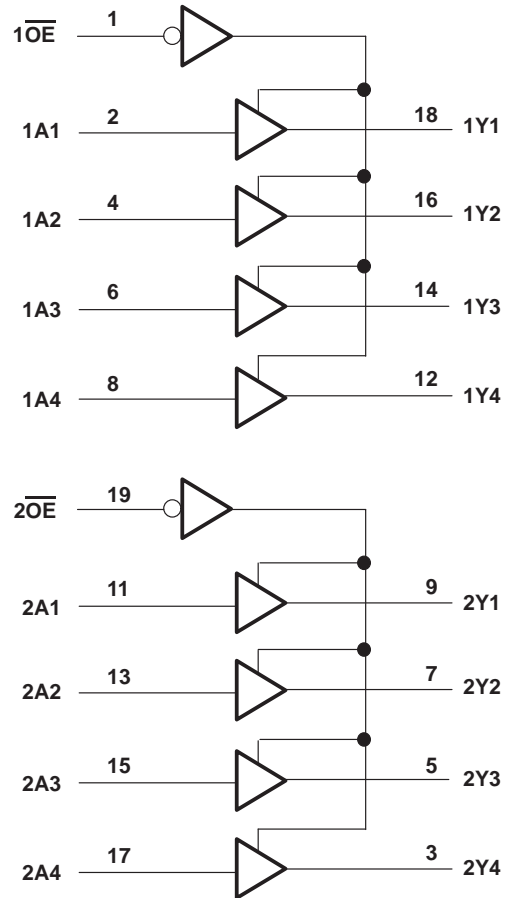

## absolute maximum ratings over operating free-air temperature range (unless otherwise noted)‡

|   |                     |
|---|---------------------|
| Supply voltage range, $V_{CC}$ .....  | - 0.5 V to 7 V      |
| Input voltage range, $V_I$ (see Note 1) .....                                       | - 0.5 V to 7 V      |
| Input current range, $I_I$ .....  | - 30 mA to 5 mA     |
| Voltage range applied to any output in the disabled or power-off state, $V_O$ ..... | - 0.5 V to 5.5 V    |
| Voltage range applied to any output in the high state, $V_{OH}$ .....               | - 0.5 V to $V_{CC}$ |
| Current into any output in the low state: SN54BCT760 .....                          | 96 mA               |
| SN74BCT760 .....  | 128 mA              |
| Operating free-air temperature range: SN54BCT760 .....                              | - 55°C to 125°C     |
| SN74BCT760 .....  | 0°C to 70°C         |
| Storage temperature range .....   | - 65°C to 150°C     |

‡ Stresses beyond those listed under "absolute maximum ratings" may cause permanent damage to the device. These are stress ratings only, and functional operation of the device at these or any other conditions beyond those indicated under "recommended operating conditions" is not implied. Exposure to absolute-maximum-rated conditions for extended periods may affect device reliability.

NOTE 1: The negative input voltage rating may be exceeded if the input clamp current rating is observed.

**SN54BCT760, SN74BCT760**  
**OCTAL BUFFERS/DRIVERS**  
**WITH OPEN-COLLECTOR OUTPUTS**  
 SCBS034B – JULY 1989 – REVISED NOVEMBER 1993

**recommended operating conditions**

|                 |                                | SN54BCT760 |     |     | SN74BCT760 |     |     | UNIT |
|-----------------|--------------------------------|------------|-----|-----|------------|-----|-----|------|
|                 |                                | MIN        | NOM | MAX | MIN        | NOM | MAX |      |
| V <sub>CC</sub> | Supply voltage                 | 4.5        | 5   | 5.5 | 4.5        | 5   | 5.5 | V    |
| V <sub>IH</sub> | High-level input voltage       | 2          |     |     | 2          |     |     | V    |
| V <sub>IL</sub> | Low-level input voltage        |            |     | 0.8 |            |     | 0.8 | V    |
| V <sub>OH</sub> | High-level output voltage      |            |     | 5.5 |            |     | 5.5 | V    |
| I <sub>IK</sub> | Input clamp current            |            |     | -18 |            |     | -18 | mA   |
| I <sub>OL</sub> | Low-level output current       |            |     | 48  |            |     | 64  | mA   |
| T <sub>A</sub>  | Operating free-air temperature | -55        |     | 125 | 0          |     | 70  | °C   |

**electrical characteristics over recommended operating free-air temperature range (unless otherwise noted)**

| PARAMETER       | TEST CONDITIONS          |                                 | SN54BCT760 |      |      | SN74BCT760 |      |      | UNIT |
|-----------------|--------------------------|---------------------------------|------------|------|------|------------|------|------|------|
|                 |                          |                                 | MIN        | TYP† | MAX  | MIN        | TYP† | MAX  |      |
| V <sub>IK</sub> | V <sub>CC</sub> = 4.5 V, | I <sub>I</sub> = -18 mA         |            |      | -1.2 |            |      | -1.2 | V    |
| V <sub>OL</sub> | V <sub>CC</sub> = 4.5 V  | I <sub>OL</sub> = 48 mA         | 0.38       | 0.55 |      |            |      |      | V    |
|                 |                          | I <sub>OL</sub> = 64 mA         |            |      |      | 0.42       | 0.55 |      |      |
| I <sub>I</sub>  | V <sub>CC</sub> = 5.5 V, | V <sub>I</sub> = 7 V            |            |      | 0.1  |            |      | 0.1  | mA   |
| I <sub>IH</sub> | V <sub>CC</sub> = 5.5 V, | V <sub>I</sub> = 2.7 V          |            |      | 20   |            |      | 20   | μA   |
| I <sub>IL</sub> | V <sub>CC</sub> = 5.5 V, | V <sub>I</sub> = 0.5 V          |            |      | -1   |            |      | -1   | mA   |
| I <sub>OH</sub> | V <sub>CC</sub> = 4.5 V, | V <sub>OH</sub> = 5.5 V         |            |      | 0.1  |            |      | 0.1  | mA   |
| I <sub>CC</sub> | V <sub>CC</sub> = 5.5 V, | Outputs high                    | 21         | 33   |      | 21         | 33   |      | mA   |
|                 |                          | Outputs low                     | 48         | 76   |      | 48         | 76   |      |      |
|                 |                          | $\overline{\text{OE}}$ disabled | 6          | 10   |      | 6          | 10   |      |      |
| C <sub>i</sub>  | V <sub>CC</sub> = 5 V,   | V <sub>I</sub> = 2.5 V or 0.5 V |            | 6    |      |            | 6    |      | pF   |
| C <sub>o</sub>  | V <sub>CC</sub> = 5 V,   | V <sub>I</sub> = 2.5 V or 0.5 V |            | 10   |      |            | 10   |      | pF   |

† All typical values are at V<sub>CC</sub> = 5 V, T<sub>A</sub> = 25°C.

**switching characteristics (see Note 2)**

| PARAMETER        | FROM (INPUT)           | TO (OUTPUT) | V <sub>CC</sub> = 5 V,<br>C <sub>L</sub> = 50 pF,<br>R <sub>L</sub> = 500 Ω,<br>T <sub>A</sub> = 25°C |     |      | V <sub>CC</sub> = 4.5 V to 5.5 V,<br>C <sub>L</sub> = 50 pF,<br>R <sub>L</sub> = 500 Ω,<br>T <sub>A</sub> = MIN to MAX‡ |      |            |      | UNIT |
|------------------|------------------------|-------------|---|-----|------|---|------|------------|------|------|
|                  |                        |             | 'BCT760   |     |      | SN54BCT760  |      | SN74BCT760 |      |      |
|                  |                        |             | MIN   | TYP | MAX  | MIN   | MAX  | MIN        | MAX  |      |
| t <sub>PLH</sub> | Any A                  | Y           | 6.3   | 8   | 9.5  | 6.3   | 11.1 | 6.3        | 10   | ns   |
| t <sub>PHL</sub> |                        |             | 2.1   | 4.3 | 6.5  | 2.1   | 7.7  | 2.1        | 7.2  |      |
| t <sub>PLH</sub> | $\overline{\text{OE}}$ | Y           | 8.6   | 13  | 15.2 | 8.6   | 18.7 | 8.6        | 17.5 | ns   |
| t <sub>PHL</sub> |                        |             | 3.2   | 6.2 | 8.9  | 3.2   | 10.4 | 3.2        | 9.9  |      |

‡ For conditions shown as MIN or MAX, use the appropriate values specified under recommended operating conditions.

NOTE 2: Load circuits and voltage waveforms are shown in Section 1.





**PACKAGING INFORMATION**

| Orderable Device | Status<br>(1) | Package Type | Package<br>Drawing | Pins | Package<br>Qty | Eco Plan<br>(2)            | Lead/Ball Finish<br>(6) | MSL Peak Temp<br>(3) | Op Temp (°C) | Device Marking<br>(4/5)                  | Samples                 |
|------------------|---------------|--------------|--------------------|------|----------------|----------------------------|-------------------------|----------------------|--------------|--|-------------------------|
| 5962-9093801M2A  | ACTIVE        | LCCC         | FK                 | 20   | 1              | TBD                        | POST-PLATE              | N / A for Pkg Type   | -55 to 125   | 5962-<br>9093801M2A<br>SNJ54BCT<br>760FK | <a href="#">Samples</a> |
| 5962-9093801MRA  | ACTIVE        | CDIP         | J                  | 20   | 1              | TBD                        | A42                     | N / A for Pkg Type   | -55 to 125   | 5962-9093801MR<br>A<br>SNJ54BCT760J      | <a href="#">Samples</a> |
| 5962-9093801MSA  | ACTIVE        | CFP          | W                  | 20   | 1              | TBD                        | A42                     | N / A for Pkg Type   | -55 to 125   | 5962-9093801MS<br>A<br>SNJ54BCT760W      | <a href="#">Samples</a> |
| SN54BCT760J      | ACTIVE        | CDIP         | J                  | 20   | 1              | TBD                        | A42                     | N / A for Pkg Type   | -55 to 125   | SN54BCT760J                              | <a href="#">Samples</a> |
| SN74BCT760DW     | ACTIVE        | SOIC         | DW                 | 20   | 25             | Green (RoHS<br>& no Sb/Br) | CU NIPDAU               | Level-1-260C-UNLIM   | 0 to 70      | BCT760                                   | <a href="#">Samples</a> |
| SN74BCT760DWG4   | ACTIVE        | SOIC         | DW                 | 20   | 25             | Green (RoHS<br>& no Sb/Br) | CU NIPDAU               | Level-1-260C-UNLIM   | 0 to 70      | BCT760                                   | <a href="#">Samples</a> |
| SN74BCT760DWR    | ACTIVE        | SOIC         | DW                 | 20   | 2000           | Green (RoHS<br>& no Sb/Br) | CU NIPDAU               | Level-1-260C-UNLIM   | 0 to 70      | BCT760                                   | <a href="#">Samples</a> |
| SN74BCT760DWRG4  | ACTIVE        | SOIC         | DW                 | 20   | 2000           | Green (RoHS<br>& no Sb/Br) | CU NIPDAU               | Level-1-260C-UNLIM   | 0 to 70      | BCT760                                   | <a href="#">Samples</a> |
| SN74BCT760N      | ACTIVE        | PDIP         | N                  | 20   | 20             | Pb-Free<br>(RoHS)          | CU NIPDAU               | N / A for Pkg Type   | 0 to 70      | SN74BCT760N                              | <a href="#">Samples</a> |
| SNJ54BCT760FK    | ACTIVE        | LCCC         | FK                 | 20   | 1              | TBD                        | POST-PLATE              | N / A for Pkg Type   | -55 to 125   | 5962-<br>9093801M2A<br>SNJ54BCT<br>760FK | <a href="#">Samples</a> |
| SNJ54BCT760J     | ACTIVE        | CDIP         | J                  | 20   | 1              | TBD                        | A42                     | N / A for Pkg Type   | -55 to 125   | 5962-9093801MR<br>A<br>SNJ54BCT760J      | <a href="#">Samples</a> |
| SNJ54BCT760W     | ACTIVE        | CFP          | W                  | 20   | 1              | TBD                        | A42                     | N / A for Pkg Type   | -55 to 125   | 5962-9093801MS<br>A<br>SNJ54BCT760W      | <a href="#">Samples</a> |

(1) The marketing status values are defined as follows:

**ACTIVE:** Product device recommended for new designs.

**LIFEBUY:** TI has announced that the device will be discontinued, and a lifetime-buy period is in effect.

**NRND:** Not recommended for new designs. Device is in production to support existing customers, but TI does not recommend using this part in a new design.

**PREVIEW:** Device has been announced but is not in production. Samples may or may not be available.

**OBSOLETE:** TI has discontinued the production of the device.

<sup>(2)</sup> Eco Plan - The planned eco-friendly classification: Pb-Free (RoHS), Pb-Free (RoHS Exempt), or Green (RoHS & no Sb/Br) - please check <http://www.ti.com/productcontent> for the latest availability information and additional product content details.

**TBD:** The Pb-Free/Green conversion plan has not been defined.

**Pb-Free (RoHS):** TI's terms "Lead-Free" or "Pb-Free" mean semiconductor products that are compatible with the current RoHS requirements for all 6 substances, including the requirement that lead not exceed 0.1% by weight in homogeneous materials. Where designed to be soldered at high temperatures, TI Pb-Free products are suitable for use in specified lead-free processes.

**Pb-Free (RoHS Exempt):** This component has a RoHS exemption for either 1) lead-based flip-chip solder bumps used between the die and package, or 2) lead-based die adhesive used between the die and leadframe. The component is otherwise considered Pb-Free (RoHS compatible) as defined above.

**Green (RoHS & no Sb/Br):** TI defines "Green" to mean Pb-Free (RoHS compatible), and free of Bromine (Br) and Antimony (Sb) based flame retardants (Br or Sb do not exceed 0.1% by weight in homogeneous material)

<sup>(3)</sup> MSL, Peak Temp. - The Moisture Sensitivity Level rating according to the JEDEC industry standard classifications, and peak solder temperature.

<sup>(4)</sup> There may be additional marking, which relates to the logo, the lot trace code information, or the environmental category on the device.

<sup>(5)</sup> Multiple Device Markings will be inside parentheses. Only one Device Marking contained in parentheses and separated by a "~" will appear on a device. If a line is indented then it is a continuation of the previous line and the two combined represent the entire Device Marking for that device.

<sup>(6)</sup> Lead/Ball Finish - Orderable Devices may have multiple material finish options. Finish options are separated by a vertical ruled line. Lead/Ball Finish values may wrap to two lines if the finish value exceeds the maximum column width.

**Important Information and Disclaimer:** The information provided on this page represents TI's knowledge and belief as of the date that it is provided. TI bases its knowledge and belief on information provided by third parties, and makes no representation or warranty as to the accuracy of such information. Efforts are underway to better integrate information from third parties. TI has taken and continues to take reasonable steps to provide representative and accurate information but may not have conducted destructive testing or chemical analysis on incoming materials and chemicals. TI and TI suppliers consider certain information to be proprietary, and thus CAS numbers and other limited information may not be available for release.

In no event shall TI's liability arising out of such information exceed the total purchase price of the TI part(s) at issue in this document sold by TI to Customer on an annual basis.

**OTHER QUALIFIED VERSIONS OF SN54BCT760, SN74BCT760 :**

- Catalog: [SN74BCT760](#)
- Enhanced Product: [SN74BCT760-EP](#), [SN74BCT760-EP](#)
- Military: [SN54BCT760](#)

NOTE: Qualified Version Definitions:

- Catalog - TI's standard catalog product
- Enhanced Product - Supports Defense, Aerospace and Medical Applications
- Military - QML certified for Military and Defense Applications

## TAPE AND REEL INFORMATION



### QUADRANT ASSIGNMENTS FOR PIN 1 ORIENTATION IN TAPE



\*All dimensions are nominal

| Device        | Package Type | Package Drawing | Pins | SPQ  | Reel Diameter (mm) | Reel Width W1 (mm) | A0 (mm) | B0 (mm) | K0 (mm) | P1 (mm) | W (mm) | Pin1 Quadrant |
|---------------|--------------|-----------------|------|------|--------------------|--------------------|---------|---------|---------|---------|--------|---------------|
| SN74BCT760DWR | SOIC         | DW              | 20   | 2000 | 330.0              | 24.4               | 10.8    | 13.3    | 2.7     | 12.0    | 24.0   | Q1            |

TAPE AND REEL BOX DIMENSIONS



\*All dimensions are nominal

| Device        | Package Type | Package Drawing | Pins | SPQ  | Length (mm) | Width (mm) | Height (mm) |
|---------------|--------------|-----------------|------|------|-------------|------------|-------------|
| SN74BCT760DWR | SOIC         | DW              | 20   | 2000 | 367.0       | 367.0      | 45.0        |

FK (S-CQCC-N\*\*)

LEADLESS CERAMIC CHIP CARRIER

28 TERMINAL SHOWN



| NO. OF TERMINALS ** | A                |                  | B                |                  |
|---------------------|------------------|------------------|------------------|------------------|
|                     | MIN              | MAX              | MIN              | MAX              |
| 20                  | 0.342<br>(8,69)  | 0.358<br>(9,09)  | 0.307<br>(7,80)  | 0.358<br>(9,09)  |
| 28                  | 0.442<br>(11,23) | 0.458<br>(11,63) | 0.406<br>(10,31) | 0.458<br>(11,63) |
| 44                  | 0.640<br>(16,26) | 0.660<br>(16,76) | 0.495<br>(12,58) | 0.560<br>(14,22) |
| 52                  | 0.740<br>(18,78) | 0.761<br>(19,32) | 0.495<br>(12,58) | 0.560<br>(14,22) |
| 68                  | 0.938<br>(23,83) | 0.962<br>(24,43) | 0.850<br>(21,6)  | 0.858<br>(21,8)  |
| 84                  | 1.141<br>(28,99) | 1.165<br>(29,59) | 1.047<br>(26,6)  | 1.063<br>(27,0)  |



4040140/D 01/11

- NOTES:
- All linear dimensions are in inches (millimeters).
  - This drawing is subject to change without notice.
  - This package can be hermetically sealed with a metal lid.
  - Falls within JEDEC MS-004

J (R-GDIP-T\*\*)

14 LEADS SHOWN

CERAMIC DUAL IN-LINE PACKAGE



| DIM \ PINS ** | 14                     | 16                     | 18                     | 20                     |
|---------------|------------------------|------------------------|------------------------|------------------------|
| A             | 0.300<br>(7,62)<br>BSC | 0.300<br>(7,62)<br>BSC | 0.300<br>(7,62)<br>BSC | 0.300<br>(7,62)<br>BSC |
| B MAX         | 0.785<br>(19,94)       | .840<br>(21,34)        | 0.960<br>(24,38)       | 1.060<br>(26,92)       |
| B MIN         | —                      | —                      | —                      | —                      |
| C MAX         | 0.300<br>(7,62)        | 0.300<br>(7,62)        | 0.310<br>(7,87)        | 0.300<br>(7,62)        |
| C MIN         | 0.245<br>(6,22)        | 0.245<br>(6,22)        | 0.220<br>(5,59)        | 0.245<br>(6,22)        |



4040083/F 03/03

- NOTES:
- A. All linear dimensions are in inches (millimeters).
  - B. This drawing is subject to change without notice.
  - C. This package is hermetically sealed with a ceramic lid using glass frit.
  - D. Index point is provided on cap for terminal identification only on press ceramic glass frit seal only.
  - E. Falls within MIL STD 1835 GDIP1-T14, GDIP1-T16, GDIP1-T18 and GDIP1-T20.

N (R-PDIP-T\*\*)

PLASTIC DUAL-IN-LINE PACKAGE

16 PINS SHOWN



- NOTES:
- A. All linear dimensions are in inches (millimeters).
  - B. This drawing is subject to change without notice.
  - Falls within JEDEC MS-001, except 18 and 20 pin minimum body length (Dim A).
  - The 20 pin end lead shoulder width is a vendor option, either half or full width.

# DW0020A



# PACKAGE OUTLINE

## SOIC - 2.65 mm max height

SOIC



4220724/A 05/2016

**NOTES:**

1. All linear dimensions are in millimeters. Dimensions in parenthesis are for reference only. Dimensioning and tolerancing per ASME Y14.5M.
2. This drawing is subject to change without notice.
3. This dimension does not include mold flash, protrusions, or gate burrs. Mold flash, protrusions, or gate burrs shall not exceed 0.15 mm per side.
4. This dimension does not include interlead flash. Interlead flash shall not exceed 0.43 mm per side.
5. Reference JEDEC registration MS-013.

# EXAMPLE BOARD LAYOUT

DW0020A

SOIC - 2.65 mm max height

SOIC



LAND PATTERN EXAMPLE  
SCALE:6X



SOLDER MASK DETAILS

4220724/A 05/2016

NOTES: (continued)

- 6. Publication IPC-7351 may have alternate designs.
- 7. Solder mask tolerances between and around signal pads can vary based on board fabrication site.

# EXAMPLE STENCIL DESIGN

DW0020A

SOIC - 2.65 mm max height

SOIC



SOLDER PASTE EXAMPLE  
BASED ON 0.125 mm THICK STENCIL  
SCALE:6X

4220724/A 05/2016

NOTES: (continued)

8. Laser cutting apertures with trapezoidal walls and rounded corners may offer better paste release. IPC-7525 may have alternate design recommendations.
9. Board assembly site may have different recommendations for stencil design.

W (R-GDFP-F20)

CERAMIC DUAL FLATPACK



- NOTES:
- A. All linear dimensions are in inches (millimeters).
  - B. This drawing is subject to change without notice.
  - C. This package can be hermetically sealed with a ceramic lid using glass frit.
  - D. Index point is provided on cap for terminal identification only.
  - E. Falls within Mil-Std 1835 GDFP2-F20

## IMPORTANT NOTICE

Texas Instruments Incorporated (TI) reserves the right to make corrections, enhancements, improvements and other changes to its semiconductor products and services per JESD46, latest issue, and to discontinue any product or service per JESD48, latest issue. Buyers should obtain the latest relevant information before placing orders and should verify that such information is current and complete.

TI's published terms of sale for semiconductor products (<http://www.ti.com/sc/docs/stdterms.htm>) apply to the sale of packaged integrated circuit products that TI has qualified and released to market. Additional terms may apply to the use or sale of other types of TI products and services.

Reproduction of significant portions of TI information in TI data sheets is permissible only if reproduction is without alteration and is accompanied by all associated warranties, conditions, limitations, and notices. TI is not responsible or liable for such reproduced documentation. Information of third parties may be subject to additional restrictions. Resale of TI products or services with statements different from or beyond the parameters stated by TI for that product or service voids all express and any implied warranties for the associated TI product or service and is an unfair and deceptive business practice. TI is not responsible or liable for any such statements.

Buyers and others who are developing systems that incorporate TI products (collectively, "Designers") understand and agree that Designers remain responsible for using their independent analysis, evaluation and judgment in designing their applications and that Designers have full and exclusive responsibility to assure the safety of Designers' applications and compliance of their applications (and of all TI products used in or for Designers' applications) with all applicable regulations, laws and other applicable requirements. Designer represents that, with respect to their applications, Designer has all the necessary expertise to create and implement safeguards that (1) anticipate dangerous consequences of failures, (2) monitor failures and their consequences, and (3) lessen the likelihood of failures that might cause harm and take appropriate actions. Designer agrees that prior to using or distributing any applications that include TI products, Designer will thoroughly test such applications and the functionality of such TI products as used in such applications.

TI's provision of technical, application or other design advice, quality characterization, reliability data or other services or information, including, but not limited to, reference designs and materials relating to evaluation modules, (collectively, "TI Resources") are intended to assist designers who are developing applications that incorporate TI products; by downloading, accessing or using TI Resources in any way, Designer (individually or, if Designer is acting on behalf of a company, Designer's company) agrees to use any particular TI Resource solely for this purpose and subject to the terms of this Notice.

TI's provision of TI Resources does not expand or otherwise alter TI's applicable published warranties or warranty disclaimers for TI products, and no additional obligations or liabilities arise from TI providing such TI Resources. TI reserves the right to make corrections, enhancements, improvements and other changes to its TI Resources. TI has not conducted any testing other than that specifically described in the published documentation for a particular TI Resource.

Designer is authorized to use, copy and modify any individual TI Resource only in connection with the development of applications that include the TI product(s) identified in such TI Resource. NO OTHER LICENSE, EXPRESS OR IMPLIED, BY ESTOPPEL OR OTHERWISE TO ANY OTHER TI INTELLECTUAL PROPERTY RIGHT, AND NO LICENSE TO ANY TECHNOLOGY OR INTELLECTUAL PROPERTY RIGHT OF TI OR ANY THIRD PARTY IS GRANTED HEREIN, including but not limited to any patent right, copyright, mask work right, or other intellectual property right relating to any combination, machine, or process in which TI products or services are used. Information regarding or referencing third-party products or services does not constitute a license to use such products or services, or a warranty or endorsement thereof. Use of TI Resources may require a license from a third party under the patents or other intellectual property of the third party, or a license from TI under the patents or other intellectual property of TI.

TI RESOURCES ARE PROVIDED "AS IS" AND WITH ALL FAULTS. TI DISCLAIMS ALL OTHER WARRANTIES OR REPRESENTATIONS, EXPRESS OR IMPLIED, REGARDING RESOURCES OR USE THEREOF, INCLUDING BUT NOT LIMITED TO ACCURACY OR COMPLETENESS, TITLE, ANY EPIDEMIC FAILURE WARRANTY AND ANY IMPLIED WARRANTIES OF MERCHANTABILITY, FITNESS FOR A PARTICULAR PURPOSE, AND NON-INFRINGEMENT OF ANY THIRD PARTY INTELLECTUAL PROPERTY RIGHTS. TI SHALL NOT BE LIABLE FOR AND SHALL NOT DEFEND OR INDEMNIFY DESIGNER AGAINST ANY CLAIM, INCLUDING BUT NOT LIMITED TO ANY INFRINGEMENT CLAIM THAT RELATES TO OR IS BASED ON ANY COMBINATION OF PRODUCTS EVEN IF DESCRIBED IN TI RESOURCES OR OTHERWISE. IN NO EVENT SHALL TI BE LIABLE FOR ANY ACTUAL, DIRECT, SPECIAL, COLLATERAL, INDIRECT, PUNITIVE, INCIDENTAL, CONSEQUENTIAL OR EXEMPLARY DAMAGES IN CONNECTION WITH OR ARISING OUT OF TI RESOURCES OR USE THEREOF, AND REGARDLESS OF WHETHER TI HAS BEEN ADVISED OF THE POSSIBILITY OF SUCH DAMAGES.

Unless TI has explicitly designated an individual product as meeting the requirements of a particular industry standard (e.g., ISO/TS 16949 and ISO 26262), TI is not responsible for any failure to meet such industry standard requirements.

Where TI specifically promotes products as facilitating functional safety or as compliant with industry functional safety standards, such products are intended to help enable customers to design and create their own applications that meet applicable functional safety standards and requirements. Using products in an application does not by itself establish any safety features in the application. Designers must ensure compliance with safety-related requirements and standards applicable to their applications. Designer may not use any TI products in life-critical medical equipment unless authorized officers of the parties have executed a special contract specifically governing such use. Life-critical medical equipment is medical equipment where failure of such equipment would cause serious bodily injury or death (e.g., life support, pacemakers, defibrillators, heart pumps, neurostimulators, and implantables). Such equipment includes, without limitation, all medical devices identified by the U.S. Food and Drug Administration as Class III devices and equivalent classifications outside the U.S.

TI may expressly designate certain products as completing a particular qualification (e.g., Q100, Military Grade, or Enhanced Product). Designers agree that it has the necessary expertise to select the product with the appropriate qualification designation for their applications and that proper product selection is at Designers' own risk. Designers are solely responsible for compliance with all legal and regulatory requirements in connection with such selection.

Designer will fully indemnify TI and its representatives against any damages, costs, losses, and/or liabilities arising out of Designer's non-compliance with the terms and provisions of this Notice.

## Looking for pricing, stock, or lifecycle information?

Click below to explore more details on WIN SOURCE:

 [View SN74BCT760N](#) on WIN SOURCE

 [Texas Instruments](#) Information

## Optimize Your Supply Chain with WIN SOURCE Solutions

-  Global Sourcing Solution
-  Obsolete Management
-  Cost Control Management
-  Shortage Management
-  Alternative Solution
-  Excess Inventory Management