



**THE DATASHEET OF
DG407DN**





Improved, 16-Channel/Dual 8-Channel, CMOS Analog Multiplexers

DG406/DG407

General Description

Maxim's redesigned DG406 and DG407 CMOS analog multiplexers now feature guaranteed matching between channels (8Ω, max) and flatness over the specified signal range (9Ω, max). These low on-resistance muxes (100Ω, max) conduct equally well in either direction and feature guaranteed low charge injection (15pC, max). In addition, these new muxes offer low input off-leakage current over temperature—less than 5nA at +85°C.

The DG406 is a 1 of 16 multiplexer/demultiplexer and the DG407 is a dual 8-channel multiplexer/demultiplexer. Both muxes operate with a +5V to +30V single supply and with ±4.5V to ±20V dual supplies. ESD protection is guaranteed to be greater than 2000V per Method 3015.7 of MIL-STD 883. These improved muxes are pin-compatible plug-in upgrades for the industry standard DG406 and DG407.

Applications

- Sample-and-Hold Circuits
- Test Equipment
- Guidance and Control Systems
- Communications Systems
- Data-Acquisition Systems
- Audio Signal Routing

Pin Configurations

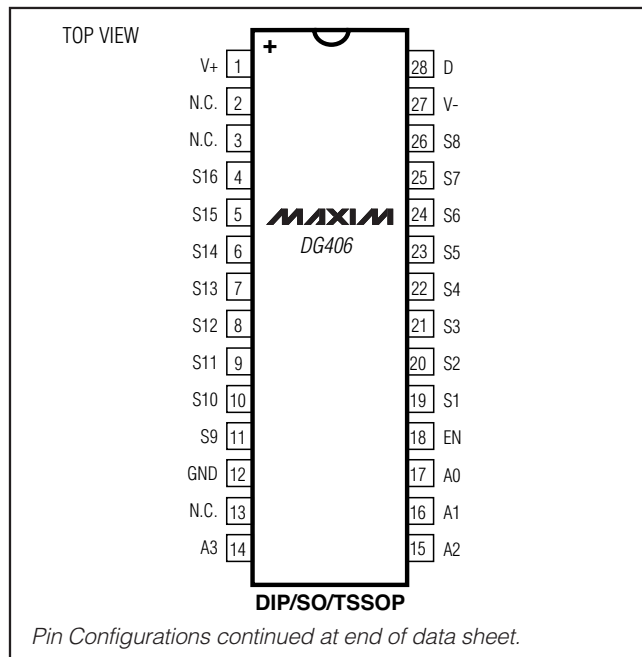

Features

- ◆ Pin-Compatible Plug-In Upgrade for Industry Standard DG406/DG407
- ◆ Guaranteed Matching Between Channels, 8Ω (max)
- ◆ Guaranteed On-Resistance Flatness, 9Ω (max)
- ◆ Guaranteed Low Charge Injection, 15pC (max)
- ◆ Low On-Resistance 100Ω (max)
- ◆ Input Leakage, 5nA (max) at +85°C
- ◆ Low Power Consumption, 1.25mW (max)
- ◆ Rail-to-Rail Signal Handling
- ◆ Digital Input Controls TTL/CMOS Compatible
- ◆ ESD Protection >2000V per Method 3015.7

Ordering Information

PART	TEMP RANGE	PIN-PACKAGE
DG406CJ+	0°C to +70°C	28 Plastic DIP
DG406CWI+	0°C to +70°C	28 Wide SO
DG406C/D	0°C to +70°C	Dice*
DG406DJ+	-40°C to +85°C	28 Plastic DIP
DG406EWI+	-40°C to +85°C	28 Wide SO
DG406DN+	-40°C to +85°C	28 PLCC
DG406AK+	-55°C to +125°C	28 CERDIP
DG406EUI+	-40°C to +85°C	28 TSSOP

Ordering Information continued at end of data sheet.

*Contact factory for dice specifications.

+Denotes a lead(Pb)-free/RoHS-compliant package.

Functional Diagrams

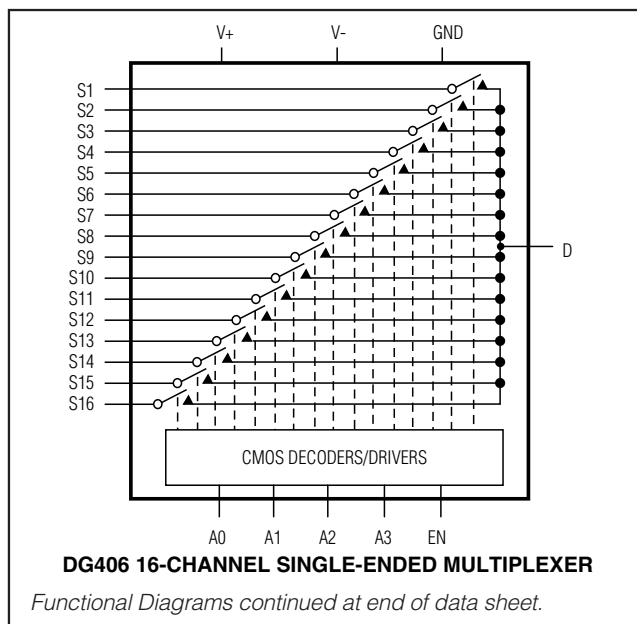

Improved, 16-Channel/Dual 8-Channel, CMOS Analog Multiplexers

ABSOLUTE MAXIMUM RATINGS

(Voltage Referenced to V-)

V+	-0.3V, 44V
GND	-0.3V, 25V
Digital Inputs, S, D (Note 1).....	(V- - 2V) to (V+ + 2V) or 30mA (whichever occurs first)
Continuous Current (any terminal)	30mA
Peak Current, S or D (pulsed at 1ms, 10% duty cycle max)	100mA
Continuous Power Dissipation (T _A = +70°C)	
28-Pin Plastic DIP (derate 9.09mW/°C above +70°C) ..	727mW
28-Pin Wide SO (derate 12.50mW/°C above +70°C) ...	1000mW
28-Pin PLCC (derate 10.53mW/°C above +70°C)	842mW

28-Pin CERDIP (derate 16.67mW/°C above +70°C)...	1333mW
28-Pin TSSOP (derate 12.8mW/°C above +70°C)	1025mW
Operating Temperature Ranges	
DG406/DG407C_	0°C to +70°C
DG406/DG407D_	-40°C to +85°C
DG406/DG407AK	-55°C to +125°C
Storage Temperature Range	-65°C to +150°C
Lead Temperature (excluding dice; soldering, 10s)	+300°C
Soldering Temperature (reflow)	
Plastic DIP, Wide SO, TSSOP	+260°C
PLCC	+245°C
CERDIP, Dice	+240°C

Note 1: Signals on S₋, D₋, A0, A1, A2, A3, or EN exceeding V+ or V- are clamped by internal diodes. Limit forward current to maximum current ratings.

Stresses beyond those listed under "Absolute Maximum Ratings" may cause permanent damage to the device. These are stress ratings only, and functional operation of the device at these or any other conditions beyond those indicated in the operational sections of the specifications is not implied. Exposure to absolute maximum rating conditions for extended periods may affect device reliability.

ELECTRICAL CHARACTERISTICS—Dual Supplies

(V+ = 15V, V- = -15V, V_{GND} = 0V, V_{AH} = +2.4V, V_{AL} = +0.8V, T_A = T_{MIN} to T_{MAX}, unless otherwise noted.)

PARAMETER	SYMBOL	CONDITIONS		MIN	TYP (Note 2)	MAX	UNITS		
SWITCH									
Analog Signal Range	V _{ANALOG}	(Note 3)		-15		+15	V		
Drain-Source On-Resistance	R _{DS(ON)}	I _S = -1.0mA, V _D = ±10V	T _A = +25°C		60	100	Ω		
			T _A = T _{MIN} to T _{MAX}			125			
On-Resistance Matching Between Channels	ΔR _{DS(ON)}	I _S = -1.0mA, V _D = ±10V (Note 4)	T _A = +25°C		1.5	8	Ω		
			T _A = T _{MIN} to T _{MAX}			10			
On-Resistance Flatness	R _{FLAT}	I _S = -1.0mA, V _D = ±5V or 0V	T _A = +25°C		1.8	9	Ω		
			T _A = T _{MIN} to T _{MAX}			12			
Source-Off Leakage Current (Note 5)	I _{S(OFF)}	V _D = +10V, V _S = ±10V, V _{EN} = 0V	T _A = +25°C	-0.5	+0.01	+0.5	nA		
			T _A = T _{MIN} to T _{MAX}	C, D		+5			
				A		+50			
Drain-Off Leakage Current (Note 5)	I _{D(OFF)}	V _D = ±10V, V _S = +10V, V _{EN} = 0V	DG406	T _A = +25°C	-1	+0.02	+1	nA	
				T _A = T _{MIN} to T _{MAX}	C, D		+40		
						A			+200
		DG407	T _A = +25°C	-1	+0.02	+1			
		V _D = +10V, V _S = ±10V, V _{EN} = 0V		T _A = T _{MIN} to T _{MAX}	C, D		+20		
					A		+100		
Drain-On Leakage Current (Note 5)	I _{D(ON)} + I _{S(ON)}	V _D = ±10V, V _S = ±10V, sequence each switch on	DG406	T _A = +25°C	-1	+0.02	+1	nA	
				T _A = T _{MIN} to T _{MAX}	C, D		+40		
						A			+200
		DG407	T _A = +25°C	-1	+0.02	+1			
		V _D = +10V, V _S = ±10V, sequence each switch on		T _A = T _{MIN} to T _{MAX}	C, D		+20		
					A		+100		

Improved, 16-Channel/Dual 8-Channel, CMOS Analog Multiplexers

DG406/DG407

ELECTRICAL CHARACTERISTICS—Dual Supplies (continued)

(V₊ = 15V, V₋ = -15V, V_{GND} = 0V, V_{AH} = +2.4V, V_{AL} = +0.8V, T_A = T_{MIN} to T_{MAX}, unless otherwise noted.)

PARAMETER	SYMBOL	CONDITIONS		MIN	TYP (Note 2)	MAX	UNITS
INPUT							
Input Current with Input Voltage High	I _{AH}	V _A = 2.4V or 15V		-1.0		+1.0	μA
Input Current with Input Voltage Low	I _{AL}	V _{EN} = 0V or 2.4V, V _A = 0V		-1.0		+1.0	μA
SUPPLY							
Power-Supply Range				±4.5		±20	V
Positive Supply Current	I ₊	V _{EN} = V _A = 0V or 5.0V	T _A = +25°C		16	30	μA
			T _A = T _{MIN} to T _{MAX}			75	
		V _{EN} = 2.4V, V _{A(ALL)} = 0V	T _A = +25°C		0.075	0.5	mA
			T _A = T _{MIN} to T _{MAX}			1	
Negative Supply Current	I ₋	V _{EN} = 2.4V, V _{A(ALL)} = 0V	T _A = +25°C		-1	+1	μA
			T _A = T _{MIN} to T _{MAX}			-10	
DYNAMIC							
Transition Time	t _{TRANS}	Figure 2	T _A = +25°C		110	300	ns
			T _A = T _{MIN} to T _{MAX}			400	
Break-Before-Make Interval	t _{OPEN}	Figure 4	T _A = +25°C		10	40	ns
Enable Turn-On Time	t _{ON(EN)}	Figure 3	T _A = +25°C		130	200	ns
			T _A = T _{MIN} to T _{MAX}			400	
Enable Turn-Off Time	t _{OFF(EN)}	Figure 3	T _A = +25°C		55	150	ns
			T _A = T _{MIN} to T _{MAX}			300	
Charge Injection (Note 3)	Q	C _L = 1.0nF, V _S = 0V, R _S = 0Ω, Figure 5	T _A = +25°C		2	15	pC
Off-Isolation (Note 6)	V _{ISO}	V _{EN} = 0V, R _L = 1kΩ, f = 100kHz, Figure 6	T _A = +25°C		-69		dB
Crosstalk Between Channels	V _{CT}	V _{EN} = 2.4V, f = 100kHz, V _{GEN} = 1VP-P, R _L = 1kΩ, Figure 7	T _A = +25°C		-92		dB
Logic Input Capacitance	C _{IN}	f = 1MHz	T _A = +25°C		8		pF
Source-Off Capacitance	C _{S(OFF)}	f = 1MHz, V _{EN} = V _S = 0V, Figure 8	T _A = +25°C		8		pF
Drain-Off Capacitance	C _{D(OFF)}	f = 1MHz, V _{EN} = 0.8V, V _D = 0V, Figure 8	DG406	T _A = +25°C	130		pF
			DG407		65		
Drain-Source On Capacitance	C _{D(ON)} + C _{S(ON)}	f = 1MHz, V _{EN} = 2.4V, V _D = 0V, Figure 8	DG406	T _A = +25°C	140		pF
			DG407		70		

Improved, 16-Channel/Dual 8-Channel, CMOS Analog Multiplexers

ELECTRICAL CHARACTERISTICS—Single Supply

(V+ = 12V, V- = 0V, VGND = 0V, VAH = +2.4V, VAL = +0.8V, TA = TMIN to TMAX, unless otherwise noted.)

PARAMETER	SYMBOL	CONDITIONS		MIN	TYP (Note 2)	MAX	UNITS
SWITCH							
Analog Signal Range	VANALOG	(Note 3)		0		12	V
Drain-Source On-Resistance	RDS(ON)	IS = -1.0mA VD = 3V or 10V	TA = +25°C		120	175	Ω
DYNAMIC							
Transition Time (Note 3)	tTRANS	VS1 = 8V, VS16 = 0V, VA = 0V, Figure 2	TA = +25°C		130	450	ns
Enable Turn-On Time (Note 3)	tON(EN)	VAL = 0V, VS1 = 5V, Figure 3	TA = +25°C		105	600	ns
Enable Turn-Off Time (Note 3)	tOFF(EN)	VAL = 0V, VS1 = 5V, Figure 3	TA = +25°C		80	300	ns
Charge Injection (Note 3)	Q	CL = 1.0nF, VS1 = 0V, RS = 0Ω	TA = +25°C		2	10	pC

Note 2: The algebraic convention where the most negative value is a minimum and the most positive value a maximum is used in this data sheet.

Note 3: Guaranteed by design.

Note 4: $\Delta RON = RON(MAX) - RON(MIN)$. On-resistance match between channels and flatness are guaranteed only with specified voltages. Flatness is defined as the difference between the maximum and minimum value of on-resistance as measured at the extremes of the specified analog signal range.

Note 5: Leakage parameters are 100% tested at the maximum-rated hot temperature and guaranteed by correlation at +25°C.

Note 6: Off-isolation = $20 \log V_D/V_S$, where V_D = output and V_S = input to off switch.

Improved, 16-Channel/Dual 8-Channel, CMOS Analog Multiplexers

Typical Operating Characteristics

($T_A = +25^\circ\text{C}$, unless otherwise noted.)

DG406/DG407

ON-RESISTANCE vs. V_D (DUAL SUPPLIES)

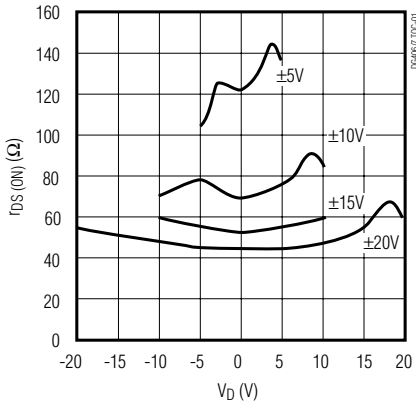

ON-RESISTANCE vs. V_D AND TEMPERATURE (DUAL SUPPLIES)

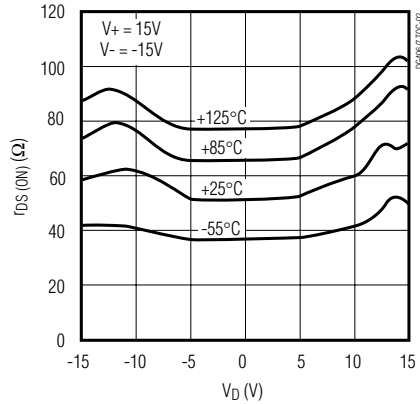

ON-RESISTANCE vs. V_D (SINGLE SUPPLY)

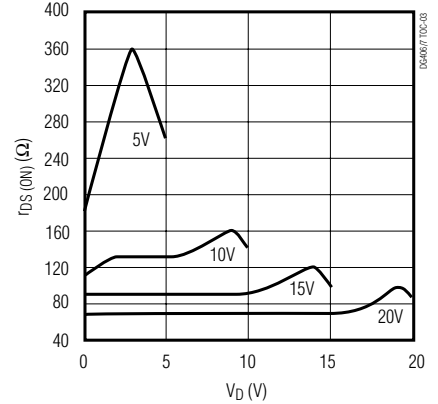

ON-RESISTANCE vs. V_D AND TEMPERATURE (SINGLE SUPPLY)

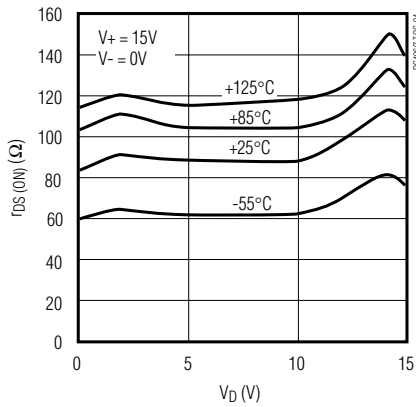

OFF LEAKAGE vs. TEMPERATURE

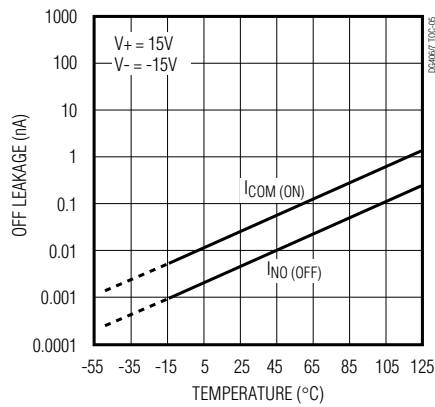

ON LEAKAGE vs. TEMPERATURE

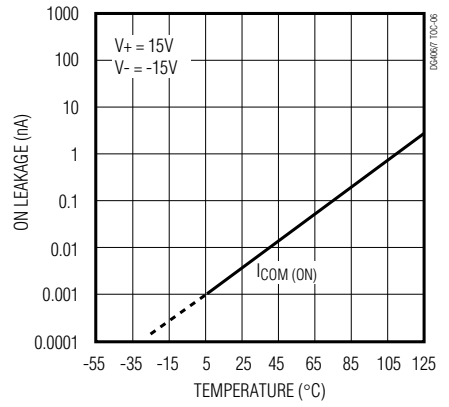

CHARGE INJECTION vs. V_D

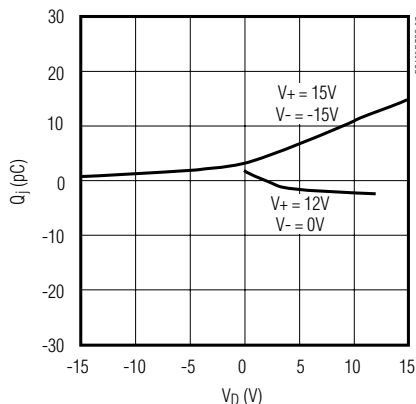

SUPPLY CURRENT vs. TEMPERATURE

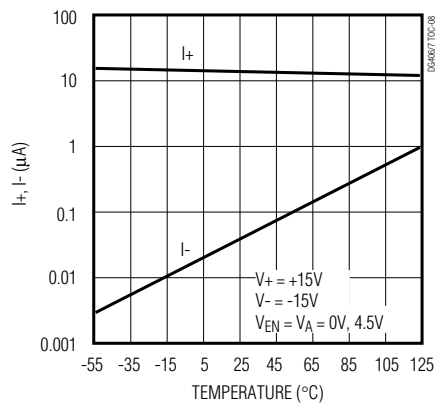

Improved, 16-Channel/Dual 8-Channel, CMOS Analog Multiplexers

Pin Descriptions

DG406 PIN	NAME	FUNCTION
1	V+	Positive Supply Voltage Input
2, 3, 13	N.C.	No Connection. Not internally connected.
4–11	S16–S9	Bidirectional Analog Inputs
12	GND	Ground
14–17	A3–A0	Address Inputs
18	EN	Enable Inputs
19–26	S1–S8	Bidirectional Analog Inputs
27	V-	Negative Supply Voltage Input
28	D	Bidirectional Output

DG407 PIN	NAME	FUNCTION
1	V+	Positive Supply Voltage Input
2	DB	Bidirectional Output B
3, 13, 14	N.C.	No Connection. Not internally connected.
4–11	S8B–S1B	Bidirectional Analog Inputs
12	GND	Ground
15, 16, 17	A2, A1, A0	Address Inputs
18	EN	Enable Input
19–26	S1A–S8A	Bidirectional Analog Inputs
27	V-	Negative Supply Voltage Input
28	DA	Bidirectional Output A

Applications Information

Operation with Supply Voltages Other than $\pm 15V$

Using supply voltages other than $\pm 15V$ reduces the analog signal range. The DG406/DG407 switches operate with $\pm 4.5V$ to $\pm 20V$ bipolar supplies or with a $+5V$ to $+30V$ single supply; connect V- to GND when operating with a single supply. Also, both device types can operate with unbalanced supplies such as $+24V$ and $-5V$. The *Typical Operating Characteristics* graphs show typical on-resistance with 20V, 15V, 10V, and 5V supplies. (Switching times increase by a factor of two or more for operation at 5V.)

Overvoltage Protection

Proper power-supply sequencing is recommended for all CMOS devices. Do not exceed the absolute maximum ratings because stresses beyond the listed ratings may cause permanent damage to the devices. Always sequence V+ on first, then V-, followed by the logic inputs and analog signals. If power-supply sequencing is not possible, add two small signal diodes in series with supply pins for overvoltage protection (Figure 1). Adding diodes reduces the analog

signal range to 1V above V+ and 1V below V-, but low switch resistance and low leakage characteristics are unaffected. Device operation is unchanged, and the difference between V+ and V- should not exceed +44V.

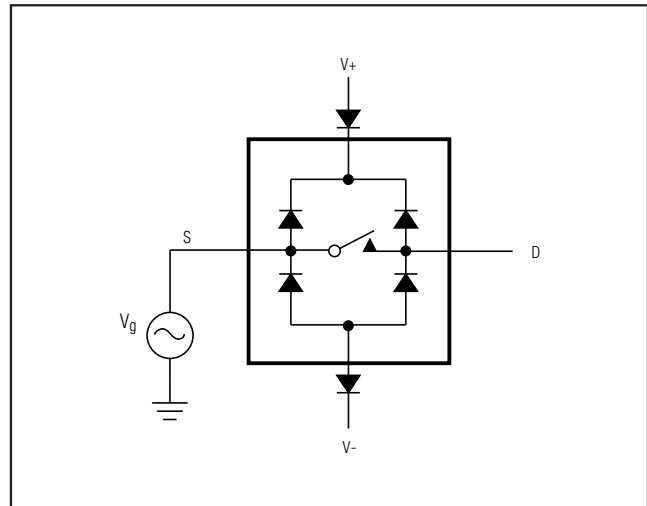

Figure 1. Overvoltage Protection Using External Blocking Diodes

Improved, 16-Channel/Dual 8-Channel, CMOS Analog Multiplexers

Test Circuits/Timing Diagrams

DG406/DG407

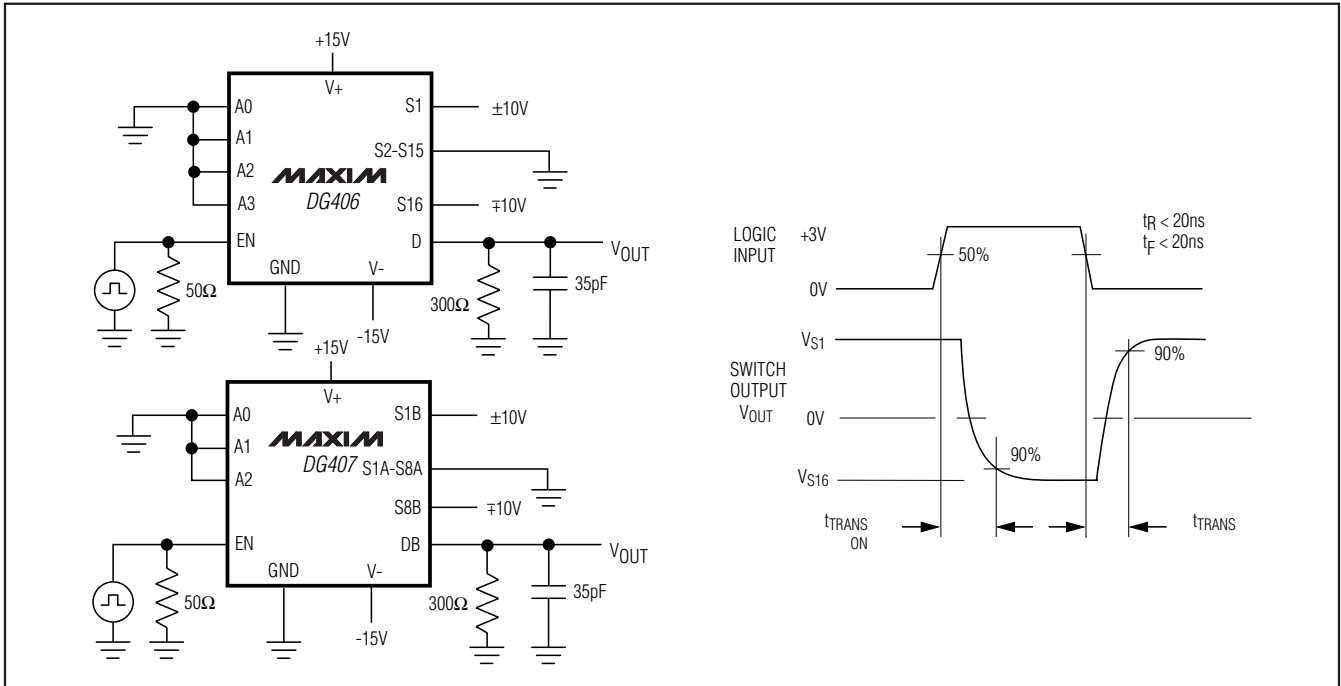

Figure 2. Transition Time

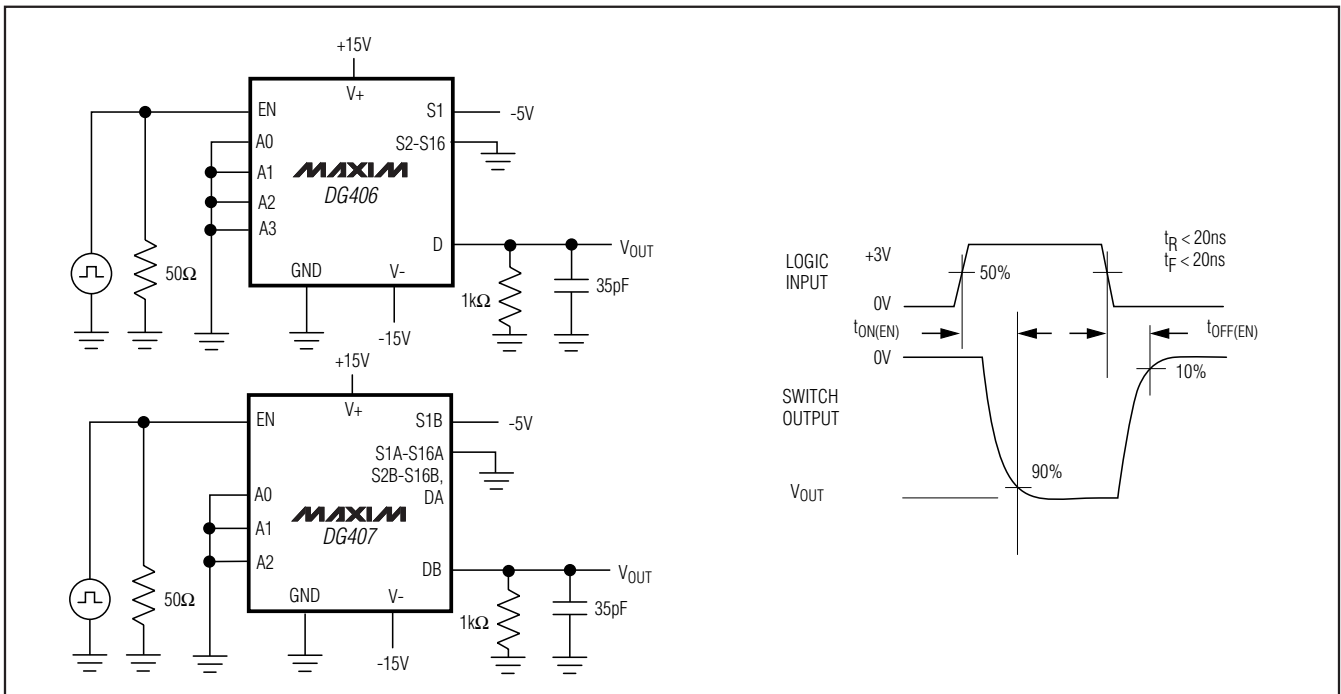

Figure 3. Enable Switching Time

Improved, 16-Channel/Dual 8-Channel, CMOS Analog Multiplexers

Test Circuits/Timing Diagrams (continued)

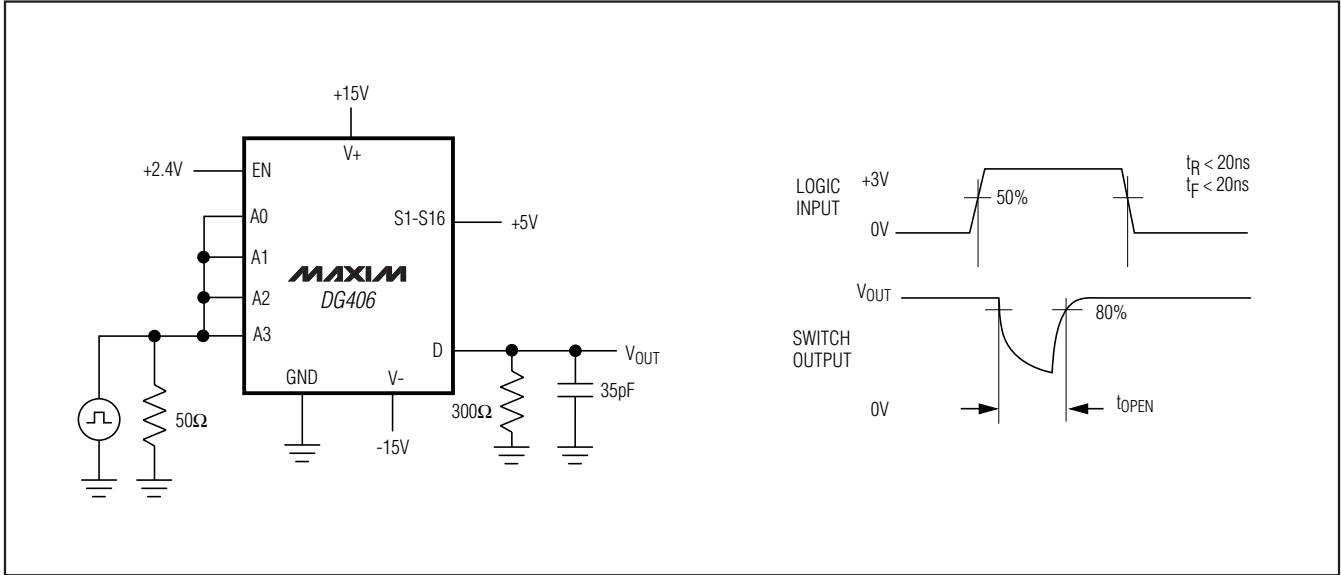

Figure 4. Break-Before-Make Interval

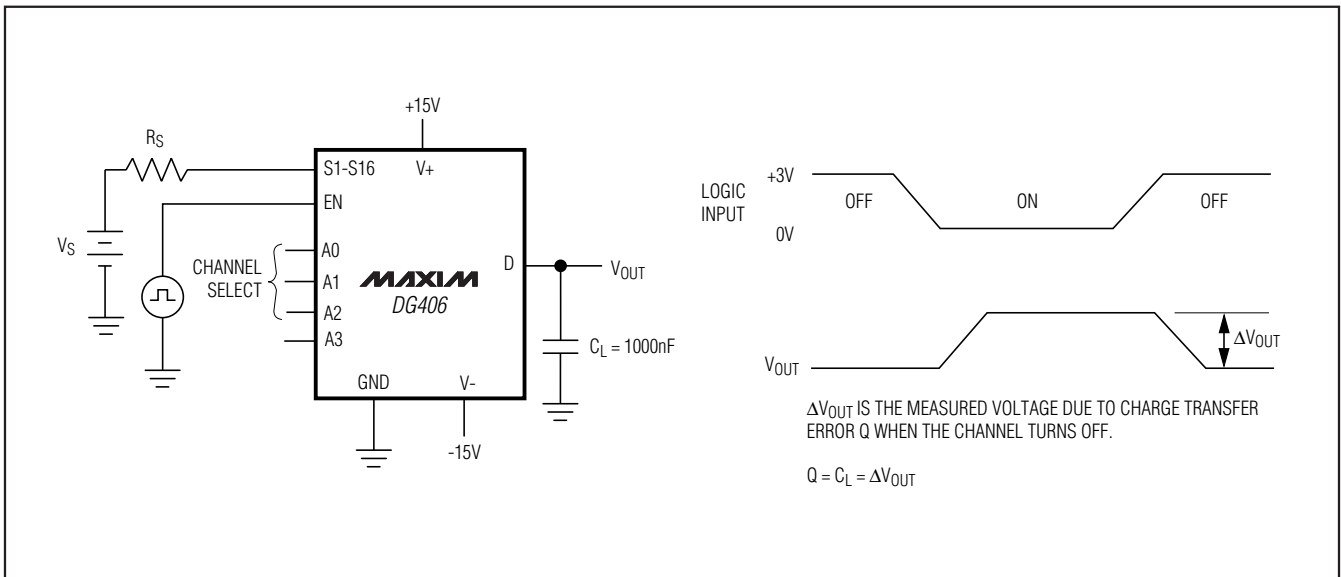

Figure 5. Charge Injection

Improved, 16-Channel/Dual 8-Channel, CMOS Analog Multiplexers

Test Circuits/Timing Diagrams (continued)

DG406/DG407

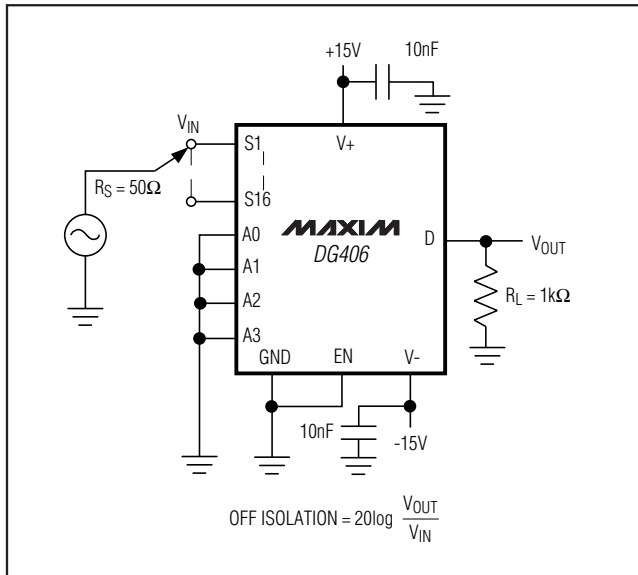

Figure 6. Off-Isolation

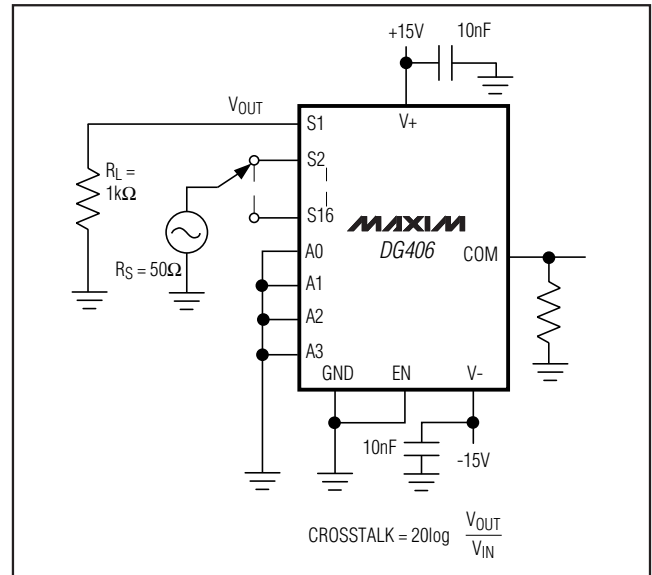

Figure 7. Crosstalk

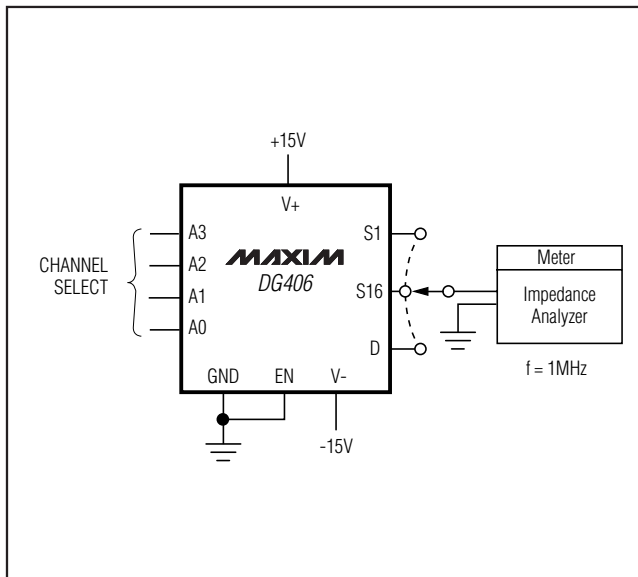
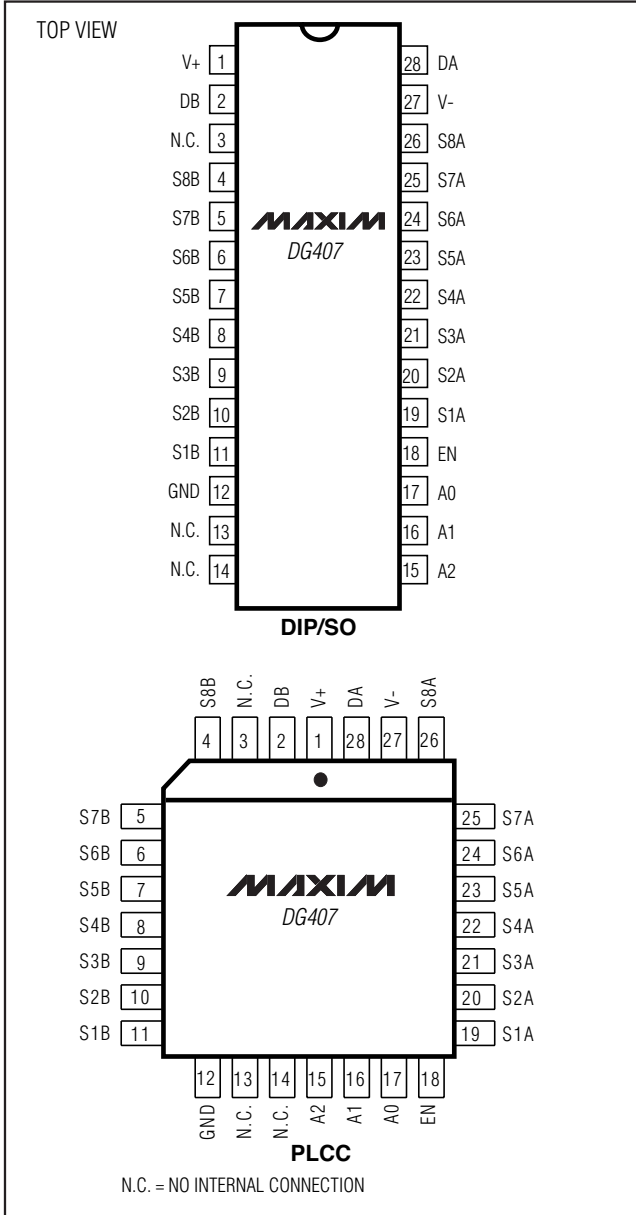

Figure 8. Source/Drain Capacitance

Improved, 16-Channel/Dual 8-Channel, CMOS Analog Multiplexers

Pin Configurations/Functional Diagrams/Truth Tables (continued)



A3	A2	A1	A0	EN	ON Switch
X	X	X	X	0	None
0	0	0	0	1	1
0	0	0	1	1	2
0	0	1	0	1	3
0	0	1	1	1	4
0	1	0	0	1	5
0	1	0	1	1	6
0	1	1	0	1	7
0	1	1	1	1	8
1	0	0	0	1	9
1	0	0	1	1	10
1	0	1	0	1	11
1	0	1	1	1	12
1	1	0	0	1	13
1	1	0	1	1	14
1	1	1	0	1	15
1	1	1	1	1	16

DG406

LOGIC "0" $V_{AL} \leq 0.8V$, LOGIC "1" = $V_{AH} \geq 2.4V$

A2	A1	A0	EN	ON Switch
X	X	X	0	None
0	0	0	1	1
0	0	1	1	2
0	1	0	1	3
0	1	1	1	4
1	0	0	1	5
1	0	1	1	6
1	1	0	1	7
1	1	1	1	8

DG407

LOGIC "0" $V_{AL} \leq 0.8V$, LOGIC "1" = $V_{AH} \geq 2.4V$

Improved, 16-Channel/Dual 8-Channel, High-Performance, CMOS Analog Multiplexers

DG406/DG407

Functional Diagrams (continued)

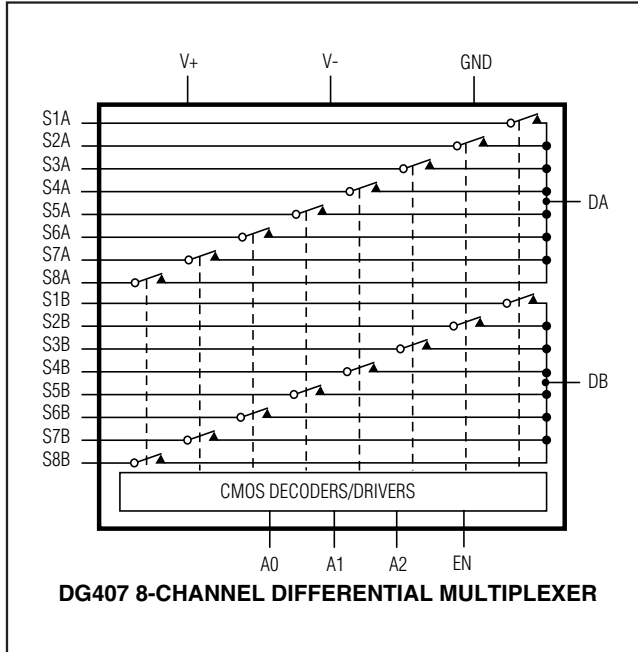

Ordering Information (continued)

PART	TEMP RANGE	PIN-PACKAGE
DG407CJ+	0°C to +70°C	28 Plastic DIP
DG407CWI+	0°C to +70°C	28 Wide SO
DG407C/D+	0°C to +70°C	Dice*
DG407DJ+	-40°C to +85°C	28 Plastic DIP
DG407EWI+	-40°C to +85°C	28 Wide SO
DG407DN+	-40°C to +85°C	28 PLCC
DG407AK	-55°C to +125°C	28 CERDIP
DG407EUI+	-40°C to +85°C	28 TSSOP

*Contact factory for dice specifications.

+Denotes a lead(Pb)-free/RoHS-compliant package.

Package Information

For the latest package outline information and land patterns, go to www.maxim-ic.com/packages. Note that a "+", "#", or "-" in the package code indicates RoHS status only. Package drawings may show a different suffix character, but the drawing pertains to the package regardless of RoHS status.

PACKAGE TYPE	PACKAGE CODE	DOCUMENT NO.
28 PDIP	P28+3	21-0044
28 Wide SO	W28+6	21-0042
28 PLCC	Q28+4	21-0049
28 TSSOP	U28+2	21-0066
28 CERDIP	J28+2	21-0046

Improved, 16-Channel/Dual 8-Channel, CMOS Analog Multiplexers

Chip Topographies

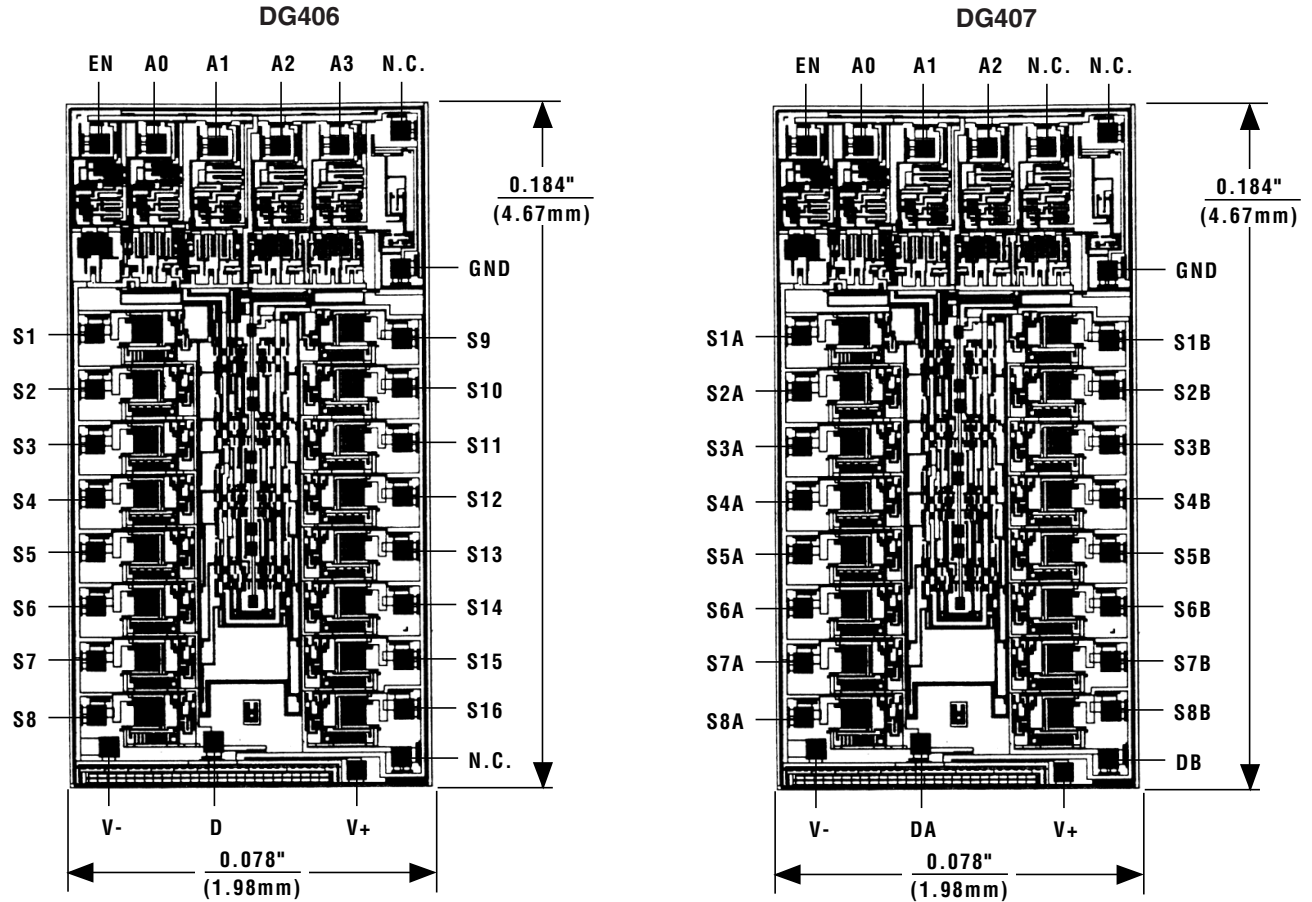

N.C. = NO INTERNAL CONNECTION

SUBSTRATE IS INTERNALLY CONNECTED TO V+

SUBSTRATE IS INTERNALLY CONNECTED TO V+

Improved, 16-Channel/Dual 8-Channel, High-Performance, CMOS Analog Multiplexers

Revision History

REVISION NUMBER	REVISION DATE	DESCRIPTION	PAGES CHANGED
6	3/10	Updated the minimum limit of the single supply range.	1, 6
		Added the soldering temperature of all packages to the <i>Absolute Maximum Ratings</i> .	2



DG406/DG407

Maxim cannot assume responsibility for use of any circuitry other than circuitry entirely embodied in a Maxim product. No circuit patent licenses are implied. Maxim reserves the right to change the circuitry and specifications without notice at any time.

Maxim Integrated Products, 120 San Gabriel Drive, Sunnyvale, CA 94086 408-737-7600 _____ 13

Looking for pricing, stock, or lifecycle information?

Click below to explore more details on WIN SOURCE:

-  [View DG407DN on WIN SOURCE](#)
-  [Maxim Integrated Information](#)

Optimize Your Supply Chain with WIN SOURCE Solutions

-  Global Sourcing Solution
-  Obsolete Management
-  Cost Control Management
-  Shortage Management
-  Alternative Solution
-  Excess Inventory Management