



**THE DATASHEET OF
TRSF3222EIDB**



FEATURES

- ESD Protection for RS-232 Bus Pins
 - ± 15 -kV Human-Body Model (HBM)
 - ± 8 -kV IEC 61000-4-2, Contact Discharge
 - ± 15 -kV IEC 61000-4-2, Air-Gap Discharge
- Meets or Exceeds the Requirements of TIA/EIA-232-F and ITU v.28 Standards
- Operates With 3-V to 5.5-V V_{CC} Supply
- Operates up to 1000 kbit/s
- Two Drivers and Two Receivers
- Low Standby Current . . . 1 μ A Typ
- External Capacitors . . . $4 \times 0.1 \mu$ F
- Accepts 5-V Logic Input With 3.3-V Supply

APPLICATIONS

- Battery-Powered Systems
- PDAs
- Notebooks
- Laptops
- Palmtop PCs
- Hand-Held Equipment

DESCRIPTION/ ORDERING INFORMATION

The TRSF3222E consists of two line drivers, two line receivers, and a dual charge-pump circuit with ± 15 -kV ESD protection pin to pin (serial-port connection pins, including GND).

The TRSF3222E meets the requirements of TIA/EIA-232-F and provides the electrical interface between an asynchronous communication controller and the serial-port connector. The charge pump and four small external capacitors allow operation from a single 3-V to 5.5-V supply. The TRSF3222E operates at typical data signaling rates up to 1000 kbit/s and is an improved drop-in replacement for industry-popular '3222 two-driver, two-receiver functions.

The TRSF3222E can be placed in the power-down mode by setting the power-down ($\overline{\text{PWRDOWN}}$) input low, which draws only 1 μ A from the power supply. When the device is powered down, the receivers remain active while the drivers are placed in the high-impedance state. Also, during power down, the onboard charge pump is disabled; $V+$ is lowered to V_{CC} , and $V-$ is raised toward GND. Receiver outputs also can be placed in the high-impedance state by setting enable ($\overline{\text{EN}}$) high.

DB, DW, OR PW PACKAGE
(TOP VIEW)

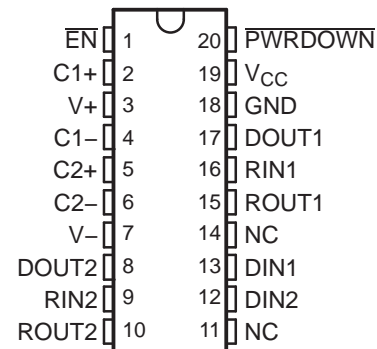

NC – No internal connection

RHL PACKAGE
(TOP VIEW)

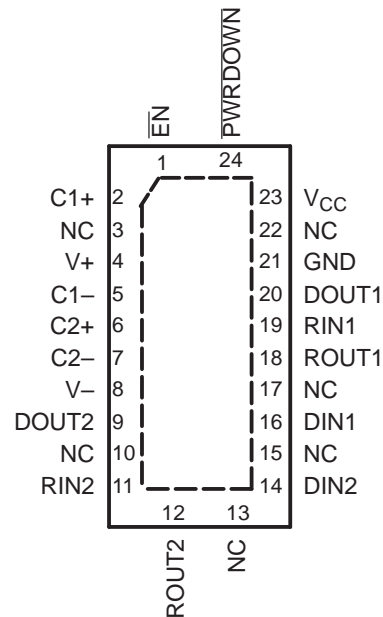

NC – No internal connection



Please be aware that an important notice concerning availability, standard warranty, and use in critical applications of Texas Instruments semiconductor products and disclaimers thereto appears at the end of this data sheet.

TRSF3222E
3-V TO 5.5-V MULTICHANNEL RS-232 LINE DRIVER/RECEIVER
WITH ±15-kV ESD PROTECTION

SLLS823–JULY 2007

ORDERING INFORMATION

T _A	PACKAGE ⁽¹⁾⁽²⁾		ORDERABLE PART NUMBER	TOP-SIDE MARKING
0°C to 70°C	SOIC – DW	Tube of 25	TRSF3222ECDW	TRSF3222EC
		Reel of 2000	TRSF3222ECDWR	
	SSOP – DB	Tube of 70	TRSF3222ECDB	RT22EC
		Reel of 2000	TRSF3222ECDBR	
	TSSOP – PW	Tube of 70	TRSF3222ECPW	RT22EC
		Reel of 2000	TRSF3222ECPWR	
–40°C to 85°C	SOIC – DW	Tube of 25	TRSF3222EIDW	TRSF3222EI
		Reel of 2000	TRSF3222EIDWR	
	SSOP – DB	Tube of 70	TRSF3222EIDB	RT22EI
		Reel of 2000	TRSF3222EIDBR	
	TSSOP – PW	Tube of 70	TRSF3222EIPW	RT22EI
		Reel of 2000	TRSF3222EIPWR	

- (1) Package drawings, standard packing quantities, thermal data, symbolization, and PCB design guidelines are available at www.ti.com/sc/package.
- (2) For the most current package and ordering information, see the Package Option Addendum at the end of this document, or see the TI website at www.ti.com.

FUNCTION TABLES

Each Driver⁽¹⁾

INPUTS		OUTPUT DOUT
DIN	PWRDOWN	
X	L	Z
L	H	H
H	H	L

- (1) H = high level, L = low level, X = irrelevant, Z = high impedance

Each Receiver⁽¹⁾

INPUTS		OUTPUT ROUT
RIN	EN	
L	L	H
H	L	L
X	H	Z
Open	L	H

- (1) H = high level, L = low level, X = irrelevant,
Z = high impedance (off),
Open = input disconnected or connected driver off

LOGIC DIAGRAM (POSITIVE LOGIC)⁽¹⁾

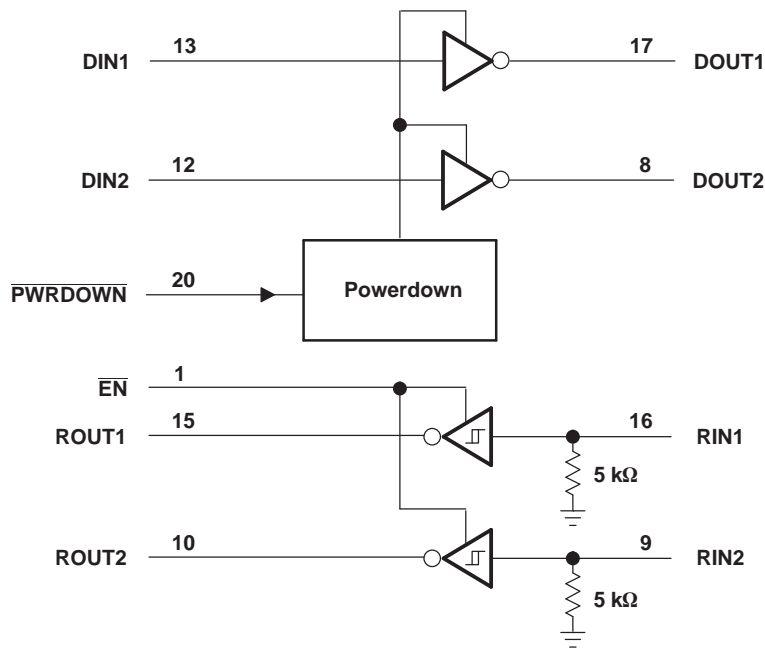

(1) Pin numbers shown are for the DB, DW, and PW packages.

Absolute Maximum Ratings⁽¹⁾

over operating free-air temperature range (unless otherwise noted)

		MIN	MAX	UNIT
V_{CC}	Supply voltage range ⁽²⁾	-0.3	6	V
V+	Positive-output supply voltage range ⁽²⁾	-0.3	7	V
V-	Negative-output supply voltage range ⁽²⁾	0.3	-7	V
V+ - V-	Supply voltage difference ⁽²⁾		13	V
V_I	Input voltage range	Driver (EN, PWRDOWN)		V
V_O	Output voltage range	Driver		V
θ_{JA}	Package thermal impedance ⁽³⁾⁽⁴⁾	DB package		°C/W
		DW package		
		PW package		
		RHL package		
T_J	Operating virtual junction temperature		150	°C
T_{stg}	Storage temperature range	-65	150	°C

- (1) Stresses beyond those listed under "absolute maximum ratings" may cause permanent damage to the device. These are stress ratings only, and functional operation of the device at these or any other conditions beyond those indicated under "recommended operating conditions" is not implied. Exposure to absolute-maximum-rated conditions for extended periods may affect device reliability.
- (2) All voltages are with respect to network GND.
- (3) Maximum power dissipation is a function of $T_J(\max)$, θ_{JA} , and T_A . The maximum allowable power dissipation at any allowable ambient temperature is $P_D = (T_J(\max) - T_A)/\theta_{JA}$. Operating at the absolute maximum T_J of 150°C can affect reliability.
- (4) The package thermal impedance is calculated in accordance with JESD 51-7.

TRSF3222E
3-V TO 5.5-V MULTICHANNEL RS-232 LINE DRIVER/RECEIVER
WITH ± 15 -kV ESD PROTECTION

SLLS823–JULY 2007

Recommended Operating Conditions⁽¹⁾

See [Figure 5](#)

			MIN	NOM	MAX	UNIT
Supply voltage		$V_{CC} = 3.3\text{ V}$	3	3.3	3.6	V
		$V_{CC} = 5\text{ V}$	4.5	5	5.5	
V_{IH}	Driver and control high-level input voltage	DIN, \overline{EN} , $\overline{PWRDOWN}$	$V_{CC} = 3.3\text{ V}$	2		V
			$V_{CC} = 5\text{ V}$	2.4		
V_{IL}	Driver and control low-level input voltage	DIN, \overline{EN} , $\overline{PWRDOWN}$			0.8	V
V_I	Driver and control input voltage	DIN, \overline{EN} , $\overline{PWRDOWN}$	0		5.5	V
V_I	Receiver input voltage		-25		25	V
T_A	Operating free-air temperature	TRSF3222EC	0		70	°C
		TRSF3222EI	-40		85	

(1) Test conditions are C1–C4 = 0.1 μF at $V_{CC} = 3.3\text{ V} \pm 0.3\text{ V}$; C1 = 0.047 μF , C2–C4 = 0.33 μF at $V_{CC} = 5\text{ V} \pm 0.5\text{ V}$.

Electrical Characteristics⁽¹⁾

over recommended ranges of supply voltage and operating free-air temperature (unless otherwise noted) (see [Figure 5](#))

PARAMETER		TEST CONDITIONS	MIN	TYP ⁽²⁾	MAX	UNIT
I_I	Input leakage current (\overline{EN} , $\overline{PWRDOWN}$)			± 0.01	± 1	μA
I_{CC}	Supply current	No load, $\overline{PWRDOWN}$ at V_{CC}		0.3	1	mA
	Supply current (powered off)	No load, $\overline{PWRDOWN}$ at GND		1	10	μA

(1) Test conditions are C1–C4 = 0.1 μF at $V_{CC} = 3.3\text{ V} \pm 0.3\text{ V}$; C1 = 0.047 μF , C2–C4 = 0.33 μF at $V_{CC} = 5\text{ V} \pm 0.5\text{ V}$.

(2) All typical values are at $V_{CC} = 3.3\text{ V}$ or $V_{CC} = 5\text{ V}$, and $T_A = 25^\circ\text{C}$.

DRIVER SECTION

Electrical Characteristics⁽¹⁾

over recommended ranges of supply voltage and operating free-air temperature (unless otherwise noted) (see [Figure 5](#))

PARAMETER		TEST CONDITIONS		MIN	TYP ⁽²⁾	MAX	UNIT
V _{OH}	High-level output voltage	DOUT at R _L = 3 k Ω to GND, DIN = GND		5	5.4		V
V _{OL}	Low-level output voltage	DOUT at R _L = 3 k Ω to GND, DIN = V _{CC}		-5	-5.4		V
I _{IH}	High-level input current	V _I = V _{CC}			± 0.01	± 1	μ A
I _{IL}	Low-level input current	V _I at GND			± 0.01	± 1	μ A
I _{OS}	Short-circuit output current ⁽³⁾	V _{CC} = 3.6 V	V _O = 0 V		± 35	± 60	mA
		V _{CC} = 5.5 V					
r _o	Output resistance	V _{CC} , V+, and V- = 0 V, V _O = ± 2 V		300	10M		Ω
I _{OZ}	Output leakage current	$\overline{\text{PWRDOWN}}$ = GND	V _{CC} = 3 V to 3.6 V, V _O = ± 12 V			± 25	μ A
			V _{CC} = 4.5 V to 5.5 V, V _O = ± 10 V			± 25	

(1) Test conditions are C1–C4 = 0.1 μ F at V_{CC} = 3.3 V \pm 0.3 V; C1 = 0.047 μ F, C2–C4 = 0.33 μ F at V_{CC} = 5 V \pm 0.5 V.

(2) All typical values are at V_{CC} = 3.3 V or V_{CC} = 5 V, and T_A = 25°C.

(3) Short-circuit durations should be controlled to prevent exceeding the device absolute power dissipation ratings, and not more than one output should be shorted at a time.

Switching Characteristics⁽¹⁾

over recommended ranges of supply voltage and operating free-air temperature (unless otherwise noted) (see [Figure 5](#))

PARAMETER		TEST CONDITIONS		MIN	TYP ⁽²⁾	MAX	UNIT
Maximum data rate (See Figure 1)	R _L = 3 k Ω , One DOUT switching	C _L = 1000 pF			250		kbit/s
		C _L = 250 pF,	V _{CC} = 3 V to 4.5 V		1000		
		C _L = 1000 pF,	V _{CC} = 4.5 V to 5.5 V		1000		
t _{sk(p)}	Pulse skew ⁽³⁾	C _L = 150 pF to 2500 pF,	R _L = 3 k Ω to 7 k Ω , See Figure 2		300		ns
SR(tr)	Slew rate, transition region (see Figure 1)	R _L = 7 k Ω ,	C _L = 150 pF to 1000 pF		8	90	V/ μ s
			C _L = 1000 pF		12	60	
		R _L = 3 k Ω	C _L = 150 pF to 250 pF		24	150	

(1) Test conditions are C1–C4 = 0.1 μ F at V_{CC} = 3.3 V \pm 0.3 V; C1 = 0.047 μ F, C2–C4 = 0.33 μ F at V_{CC} = 5 V \pm 0.5 V.

(2) All typical values are at V_{CC} = 3.3 V or V_{CC} = 5 V, and T_A = 25°C.

(3) Pulse skew is defined as |t_{PLH} - t_{PHL}| of each channel of the same device.

TRSF3222E

3-V TO 5.5-V MULTICHANNEL RS-232 LINE DRIVER/RECEIVER

WITH ± 15 -kV ESD PROTECTION

SLLS823–JULY 2007

RECEIVER SECTION

Electrical Characteristics⁽¹⁾

over recommended ranges of supply voltage and operating free-air temperature (unless otherwise noted) (see [Figure 5](#))

PARAMETER		TEST CONDITIONS	MIN	TYP ⁽²⁾	MAX	UNIT
V _{OH}	High-level output voltage	I _{OH} = -1 mA	V _{CC} - 0.6	V _{CC} - 0.1		V
V _{OL}	Low-level output voltage	I _{OL} = 1.6 mA			0.4	V
V _{IT+}	Positive-going input threshold voltage	V _{CC} = 3.3 V		1.5	2.4	V
		V _{CC} = 5 V		1.8	2.4	
V _{IT-}	Negative-going input threshold voltage	V _{CC} = 3.3 V	0.6	1.2		V
		V _{CC} = 5 V	0.8	1.5		
V _{hys}	Input hysteresis (V _{IT+} - V _{IT-})			0.3		V
I _{OZ}	Output leakage current	$\overline{\text{EN}} = 1$		± 0.05	± 10	μA
r _i	Input resistance	V _I = ± 3 V to ± 25 V	3	5	7	k Ω

(1) Test conditions are C1–C4 = 0.1 μF at V_{CC} = 3.3 V \pm 0.3 V; C1 = 0.047 μF , C2–C4 = 0.33 μF at V_{CC} = 5 V \pm 0.5 V.

(2) All typical values are at V_{CC} = 3.3 V or V_{CC} = 5 V, and T_A = 25°C.

Switching Characteristics⁽¹⁾

over recommended ranges of supply voltage and operating free-air temperature (unless otherwise noted)

PARAMETER		TEST CONDITIONS	TYP ⁽²⁾	UNIT
t _{PLH}	Propagation delay time, low- to high-level output	C _L = 150 pF, See Figure 3	300	ns
t _{PHL}	Propagation delay time, high- to low-level output	C _L = 150 pF, See Figure 3	300	ns
t _{en}	Output enable time	C _L = 150 pF, R _L = 3 k Ω , See Figure 4	200	ns
t _{dis}	Output disable time	C _L = 150 pF, R _L = 3 k Ω , See Figure 4	200	ns
t _{sk(p)}	Pulse skew ⁽³⁾	See Figure 3	300	ns

(1) Test conditions are C1–C4 = 0.1 μF at V_{CC} = 3.3 V \pm 0.3 V; C1 = 0.047 μF , C2–C4 = 0.33 μF at V_{CC} = 5 V \pm 0.5 V.

(2) All typical values are at V_{CC} = 3.3 V or V_{CC} = 5 V, and T_A = 25°C.

(3) Pulse skew is defined as |t_{PLH} - t_{PHL}| of each channel of the same device.

PARAMETER MEASUREMENT INFORMATION

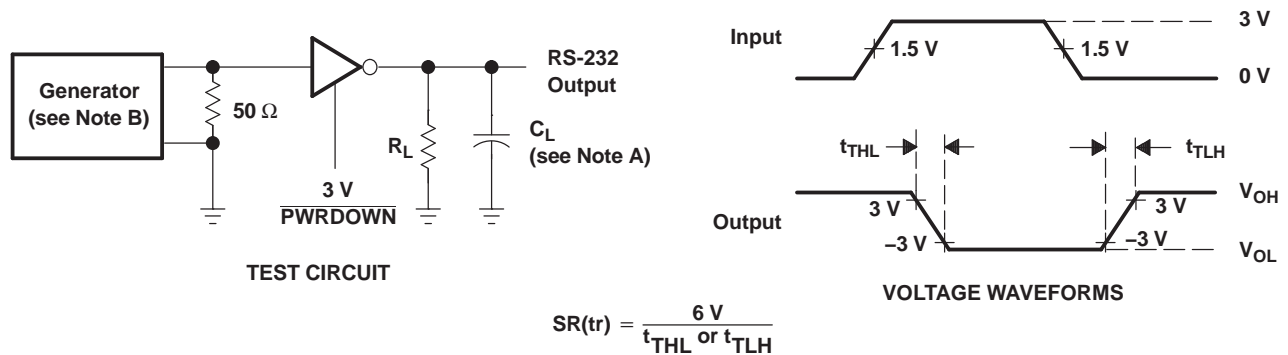

- A. C_L includes probe and jig capacitance.
- B. The pulse generator has the following characteristics: PRR = 250 kbit/s, $Z_O = 50\ \Omega$, 50% duty cycle, $t_r \leq 10\text{ ns}$, $t_f \leq 10\text{ ns}$.

Figure 1. Driver Slew Rate

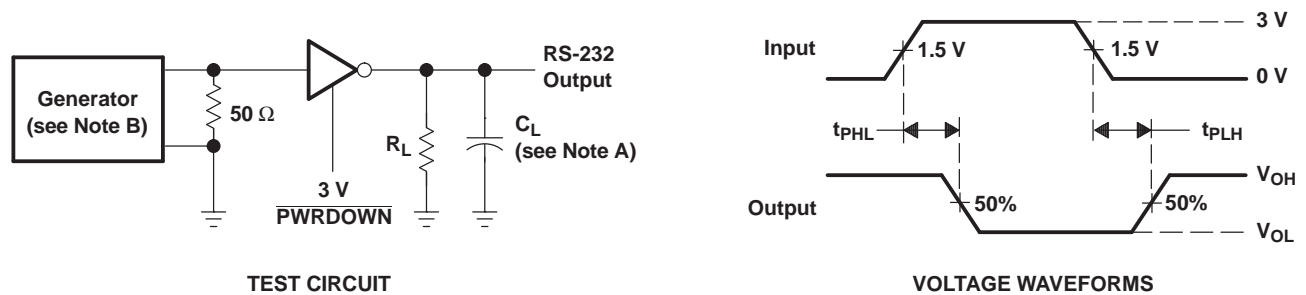

- A. C_L includes probe and jig capacitance.
- B. The pulse generator has the following characteristics: PRR = 250 kbit/s, $Z_O = 50\ \Omega$, 50% duty cycle, $t_r \leq 10\text{ ns}$, $t_f \leq 10\text{ ns}$.

Figure 2. Driver Pulse Skew

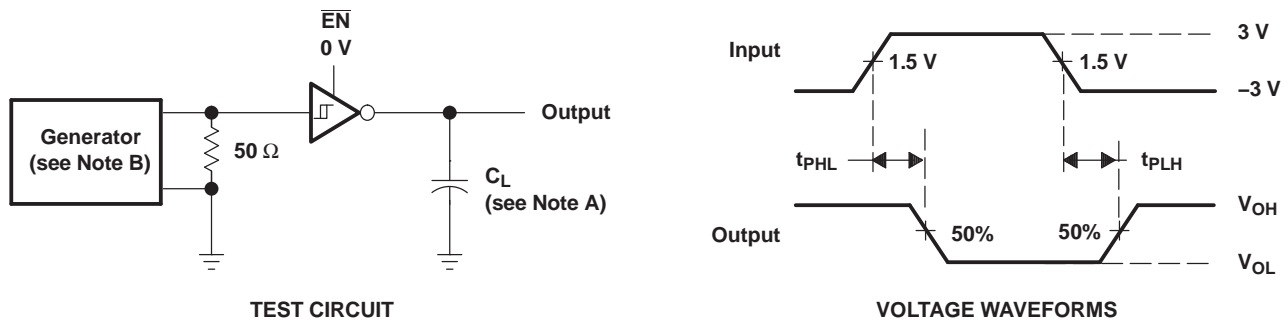

- A. C_L includes probe and jig capacitance.
- B. The pulse generator has the following characteristics: $Z_O = 50\ \Omega$, 50% duty cycle, $t_r \leq 10\text{ ns}$, $t_f \leq 10\text{ ns}$.

Figure 3. Receiver Propagation Delay Times

PARAMETER MEASUREMENT INFORMATION (continued)

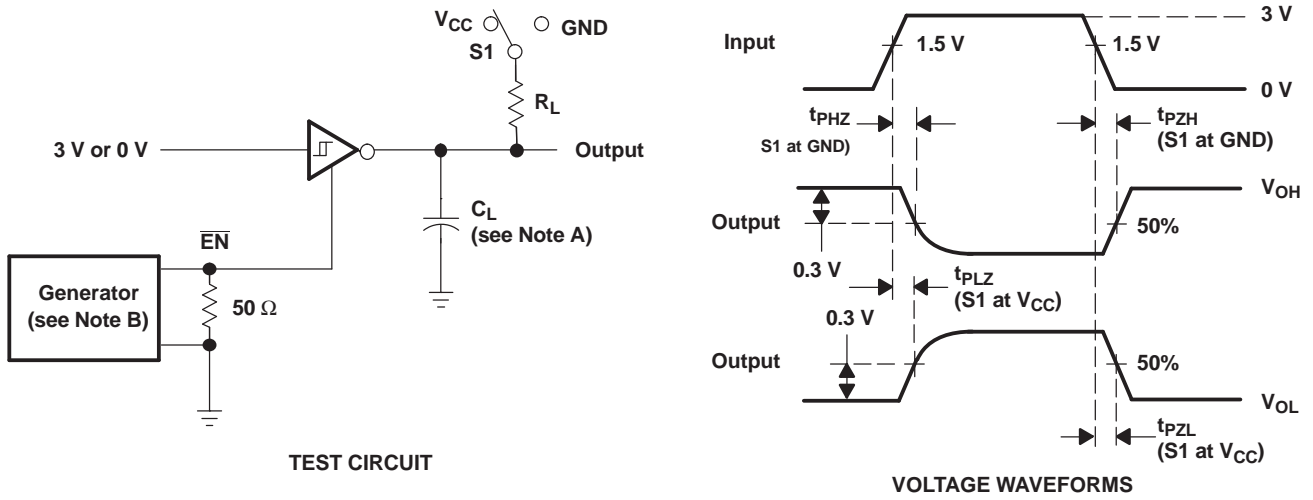

- A. C_L includes probe and jig capacitance.
- B. The pulse generator has the following characteristics: $Z_O = 50 \Omega$, 50% duty cycle, $t_r \leq 10$ ns, $t_f \leq 10$ ns.

Figure 4. Receiver Enable and Disable Times

APPLICATION INFORMATION

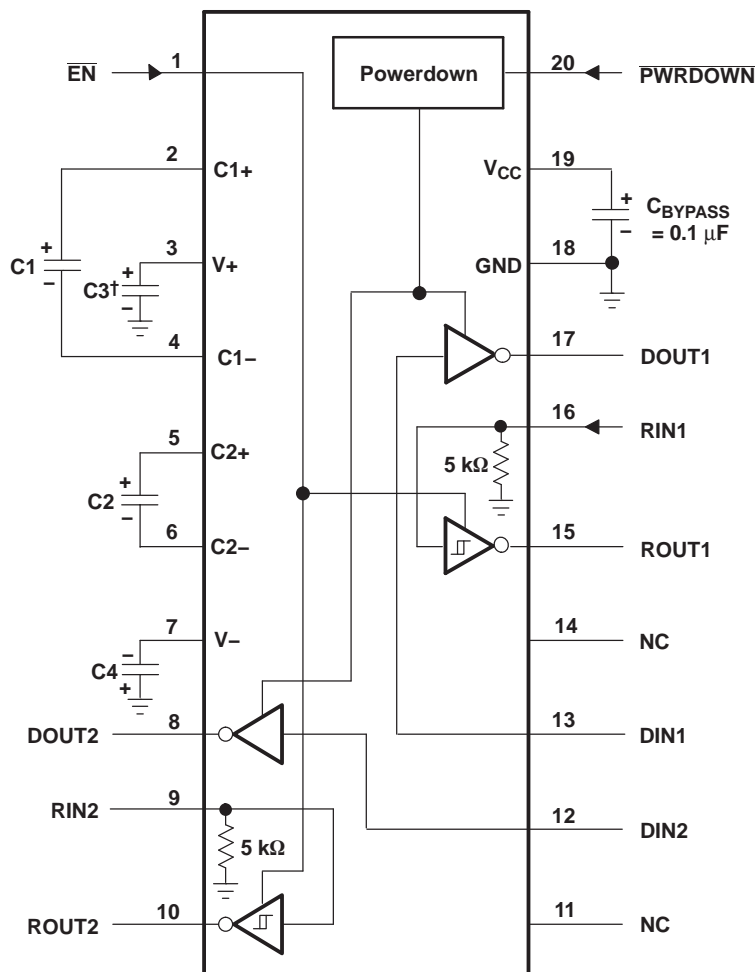

† C3 can be connected to V_{CC} or GND.

NOTES: A. Resistor values shown are nominal.

B. NC – No internal connection

C. Nonpolarized ceramic capacitors are acceptable. If polarized tantalum or electrolytic capacitors are used, they should be connected as shown.

V_{CC} vs CAPACITOR VALUES

V_{CC}	C1	C2, C3, and C4
3.3 V \pm 0.3 V	0.1 μ F	0.1 μ F
5 V \pm 0.5 V	0.047 μ F	0.33 μ F
3 V to 5.5 V	0.1 μ F	0.47 μ F

Figure 5. Typical Operating Circuit and Capacitor Values

PACKAGING INFORMATION

Orderable Device	Status (1)	Package Type	Package Drawing	Pins	Package Qty	Eco Plan (2)	Lead/Ball Finish	MSL Peak Temp (3)	Op Temp (°C)	Device Marking (4/5)	Samples
TRSF3222ECDB	ACTIVE	SSOP	DB	20	70	Green (RoHS & no Sb/Br)	CU NIPDAU	Level-1-260C-UNLIM	0 to 70	RT22EC	Samples
TRSF3222ECDBG4	ACTIVE	SSOP	DB	20	70	Green (RoHS & no Sb/Br)	CU NIPDAU	Level-1-260C-UNLIM	0 to 70	RT22EC	Samples
TRSF3222ECDBG4	OBSOLETE	SSOP	DB	20		TBD	Call TI	Call TI	0 to 70		
TRSF3222ECDWG4	OBSOLETE	SOIC	DW	20		TBD	Call TI	Call TI	0 to 70		
TRSF3222ECDWR	ACTIVE	SOIC	DW	20	2000	Green (RoHS & no Sb/Br)	CU NIPDAU	Level-1-260C-UNLIM	0 to 70	TRSF3222EC	Samples
TRSF3222ECDWRG4	ACTIVE	SOIC	DW	20	2000	Green (RoHS & no Sb/Br)	CU NIPDAU	Level-1-260C-UNLIM	0 to 70	TRSF3222EC	Samples
TRSF3222ECPWG4	OBSOLETE	TSSOP	PW	20		TBD	Call TI	Call TI	0 to 70		
TRSF3222ECPWR	ACTIVE	TSSOP	PW	20	2000	Green (RoHS & no Sb/Br)	CU NIPDAU	Level-1-260C-UNLIM	0 to 70	RT22EC	Samples
TRSF3222ECPWRG4	ACTIVE	TSSOP	PW	20	2000	Green (RoHS & no Sb/Br)	CU NIPDAU	Level-1-260C-UNLIM	0 to 70	RT22EC	Samples
TRSF3222EIDBG4	OBSOLETE	SSOP	DB	20		TBD	Call TI	Call TI	-40 to 85		
TRSF3222EIDBRG4	OBSOLETE	SSOP	DB	20		TBD	Call TI	Call TI	-40 to 85		
TRSF3222EIDW	ACTIVE	SOIC	DW	20	25	Green (RoHS & no Sb/Br)	CU NIPDAU	Level-1-260C-UNLIM	-40 to 85	TRSF3222EI	Samples
TRSF3222EIDWG4	ACTIVE	SOIC	DW	20	25	Green (RoHS & no Sb/Br)	CU NIPDAU	Level-1-260C-UNLIM	-40 to 85	TRSF3222EI	Samples
TRSF3222EIDWR	ACTIVE	SOIC	DW	20	2000	Green (RoHS & no Sb/Br)	CU NIPDAU	Level-1-260C-UNLIM	-40 to 85	TRSF3222EI	Samples
TRSF3222EIDWRG4	ACTIVE	SOIC	DW	20	2000	Green (RoHS & no Sb/Br)	CU NIPDAU	Level-1-260C-UNLIM	-40 to 85	TRSF3222EI	Samples
TRSF3222EIPW	ACTIVE	TSSOP	PW	20	70	Green (RoHS & no Sb/Br)	CU NIPDAU	Level-1-260C-UNLIM	-40 to 85	RT22EI	Samples
TRSF3222EIPWG4	ACTIVE	TSSOP	PW	20	70	Green (RoHS & no Sb/Br)	CU NIPDAU	Level-1-260C-UNLIM	-40 to 85	RT22EI	Samples
TRSF3222EIPWR	ACTIVE	TSSOP	PW	20	2000	Green (RoHS & no Sb/Br)	CU NIPDAU	Level-1-260C-UNLIM	-40 to 85	RT22EI	Samples
TRSF3222EIPWRG4	ACTIVE	TSSOP	PW	20	2000	Green (RoHS & no Sb/Br)	CU NIPDAU	Level-1-260C-UNLIM	-40 to 85	RT22EI	Samples

(1) The marketing status values are defined as follows:

ACTIVE: Product device recommended for new designs.

LIFEBUY: TI has announced that the device will be discontinued, and a lifetime-buy period is in effect.

NRND: Not recommended for new designs. Device is in production to support existing customers, but TI does not recommend using this part in a new design.

PREVIEW: Device has been announced but is not in production. Samples may or may not be available.

OBSOLETE: TI has discontinued the production of the device.

(2) Eco Plan - The planned eco-friendly classification: Pb-Free (RoHS), Pb-Free (RoHS Exempt), or Green (RoHS & no Sb/Br) - please check <http://www.ti.com/productcontent> for the latest availability information and additional product content details.

TBD: The Pb-Free/Green conversion plan has not been defined.

Pb-Free (RoHS): TI's terms "Lead-Free" or "Pb-Free" mean semiconductor products that are compatible with the current RoHS requirements for all 6 substances, including the requirement that lead not exceed 0.1% by weight in homogeneous materials. Where designed to be soldered at high temperatures, TI Pb-Free products are suitable for use in specified lead-free processes.

Pb-Free (RoHS Exempt): This component has a RoHS exemption for either 1) lead-based flip-chip solder bumps used between the die and package, or 2) lead-based die adhesive used between the die and leadframe. The component is otherwise considered Pb-Free (RoHS compatible) as defined above.

Green (RoHS & no Sb/Br): TI defines "Green" to mean Pb-Free (RoHS compatible), and free of Bromine (Br) and Antimony (Sb) based flame retardants (Br or Sb do not exceed 0.1% by weight in homogeneous material)

(3) MSL, Peak Temp. -- The Moisture Sensitivity Level rating according to the JEDEC industry standard classifications, and peak solder temperature.

(4) There may be additional marking, which relates to the logo, the lot trace code information, or the environmental category on the device.

(5) Multiple Device Markings will be inside parentheses. Only one Device Marking contained in parentheses and separated by a "--" will appear on a device. If a line is indented then it is a continuation of the previous line and the two combined represent the entire Device Marking for that device.

Important Information and Disclaimer: The information provided on this page represents TI's knowledge and belief as of the date that it is provided. TI bases its knowledge and belief on information provided by third parties, and makes no representation or warranty as to the accuracy of such information. Efforts are underway to better integrate information from third parties. TI has taken and continues to take reasonable steps to provide representative and accurate information but may not have conducted destructive testing or chemical analysis on incoming materials and chemicals. TI and TI suppliers consider certain information to be proprietary, and thus CAS numbers and other limited information may not be available for release.

In no event shall TI's liability arising out of such information exceed the total purchase price of the TI part(s) at issue in this document sold by TI to Customer on an annual basis.

TAPE AND REEL INFORMATION

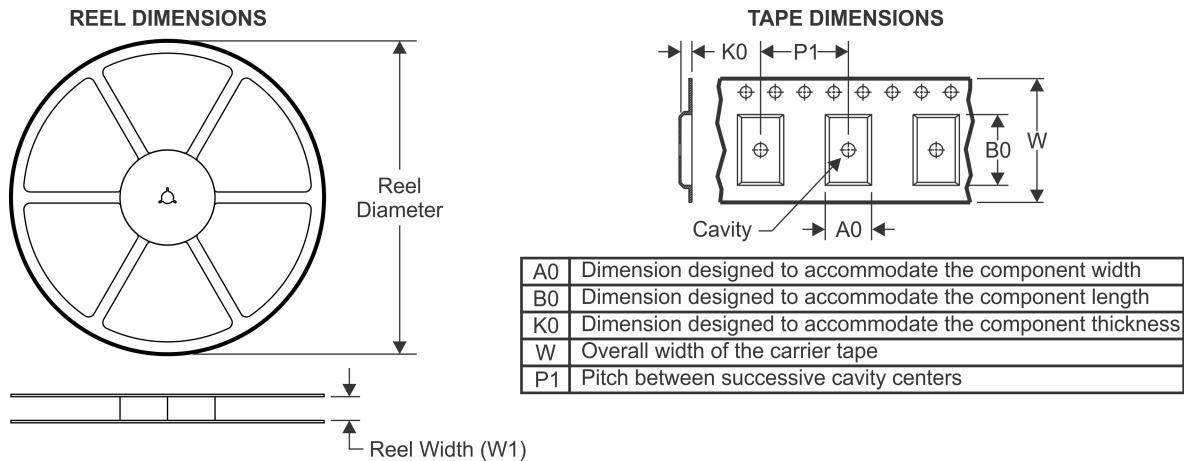

QUADRANT ASSIGNMENTS FOR PIN 1 ORIENTATION IN TAPE

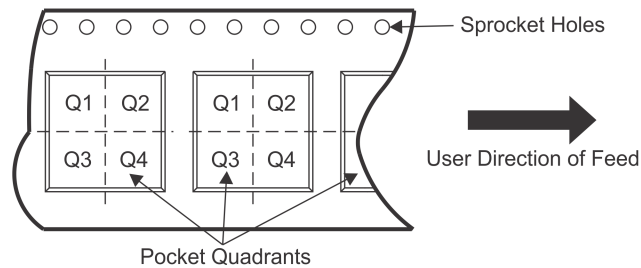

*All dimensions are nominal

Device	Package Type	Package Drawing	Pins	SPQ	Reel Diameter (mm)	Reel Width W1 (mm)	A0 (mm)	B0 (mm)	K0 (mm)	P1 (mm)	W (mm)	Pin1 Quadrant
TRSF3222ECDWR	SOIC	DW	20	2000	330.0	24.4	10.8	13.3	2.7	12.0	24.0	Q1
TRSF3222ECPWR	TSSOP	PW	20	2000	330.0	16.4	6.95	7.1	1.6	8.0	16.0	Q1
TRSF3222EIDWR	SOIC	DW	20	2000	330.0	24.4	10.8	13.3	2.7	12.0	24.0	Q1
TRSF3222EIPWR	TSSOP	PW	20	2000	330.0	16.4	6.95	7.1	1.6	8.0	16.0	Q1

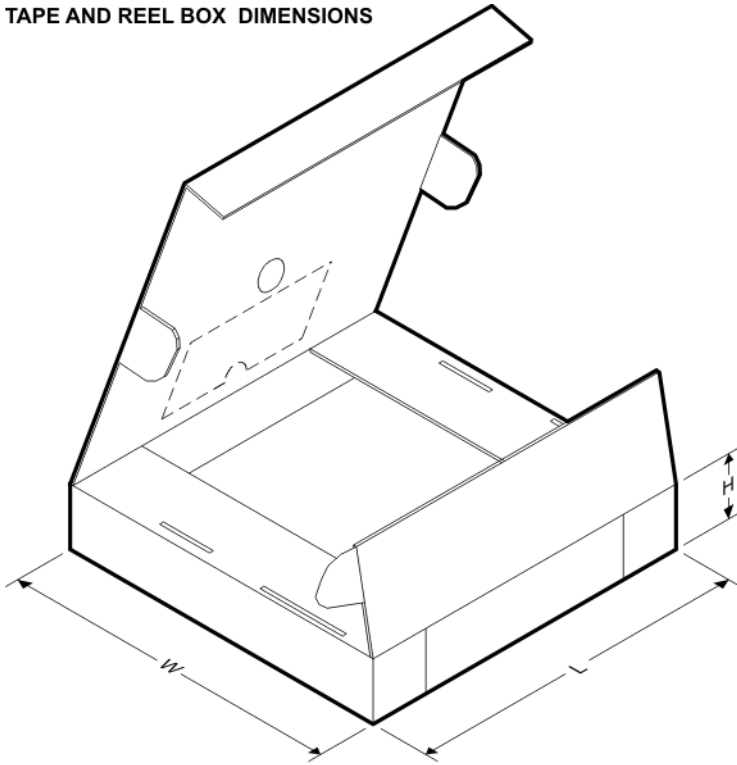
TAPE AND REEL BOX DIMENSIONS

*All dimensions are nominal

Device	Package Type	Package Drawing	Pins	SPQ	Length (mm)	Width (mm)	Height (mm)
TRSF3222ECDWR	SOIC	DW	20	2000	367.0	367.0	45.0
TRSF3222ECPWR	TSSOP	PW	20	2000	367.0	367.0	38.0
TRSF3222EIDWR	SOIC	DW	20	2000	367.0	367.0	45.0
TRSF3222EIPWR	TSSOP	PW	20	2000	367.0	367.0	38.0

DW (R-PDSO-G20)

PLASTIC SMALL OUTLINE

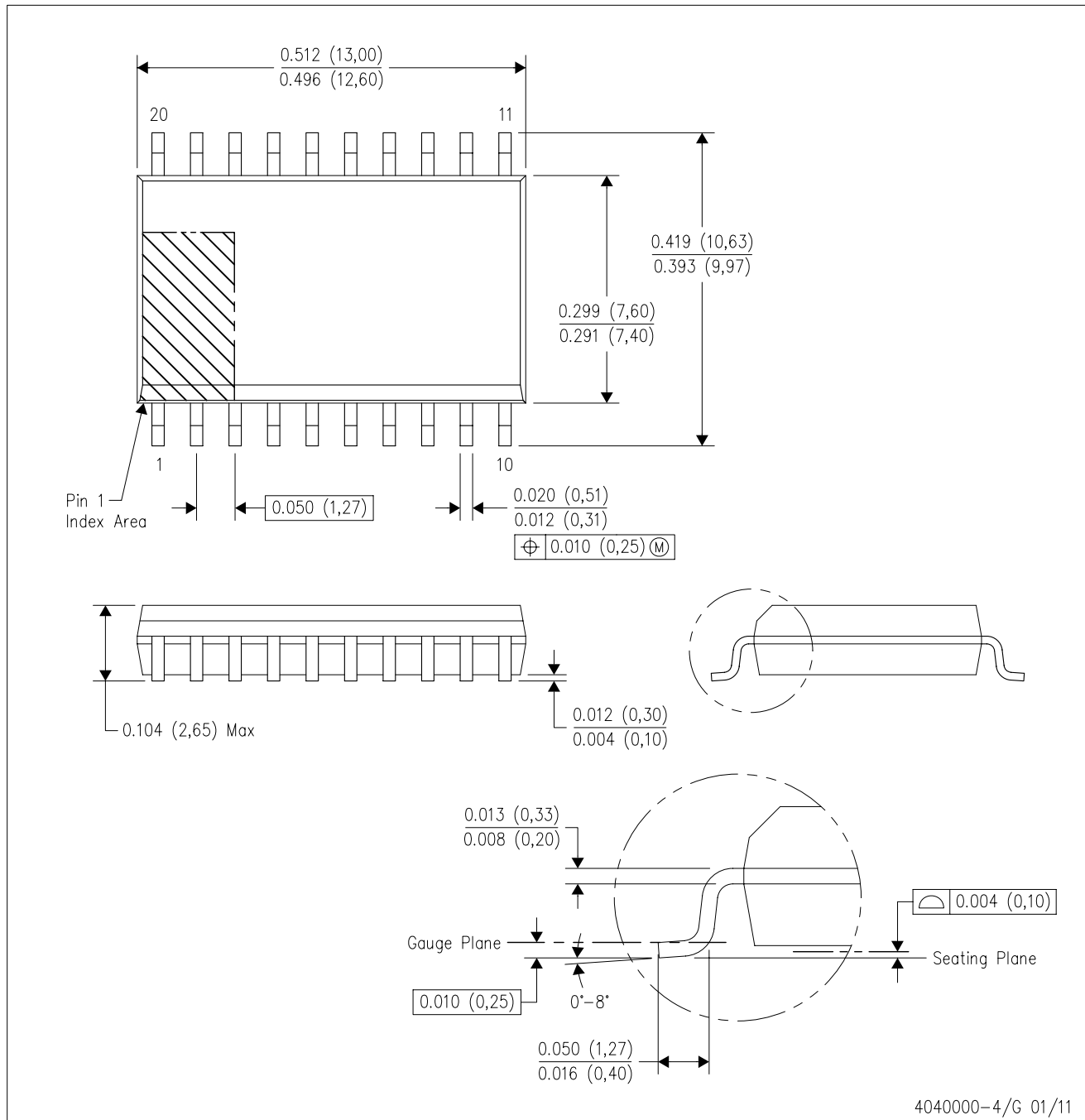

- NOTES:
- A. All linear dimensions are in inches (millimeters). Dimensioning and tolerancing per ASME Y14.5M-1994.
 - B. This drawing is subject to change without notice.
 - C. Body dimensions do not include mold flash or protrusion not to exceed 0.006 (0,15).
 - D. Falls within JEDEC MS-013 variation AC.

DW (R-PDSO-G20)

PLASTIC SMALL OUTLINE

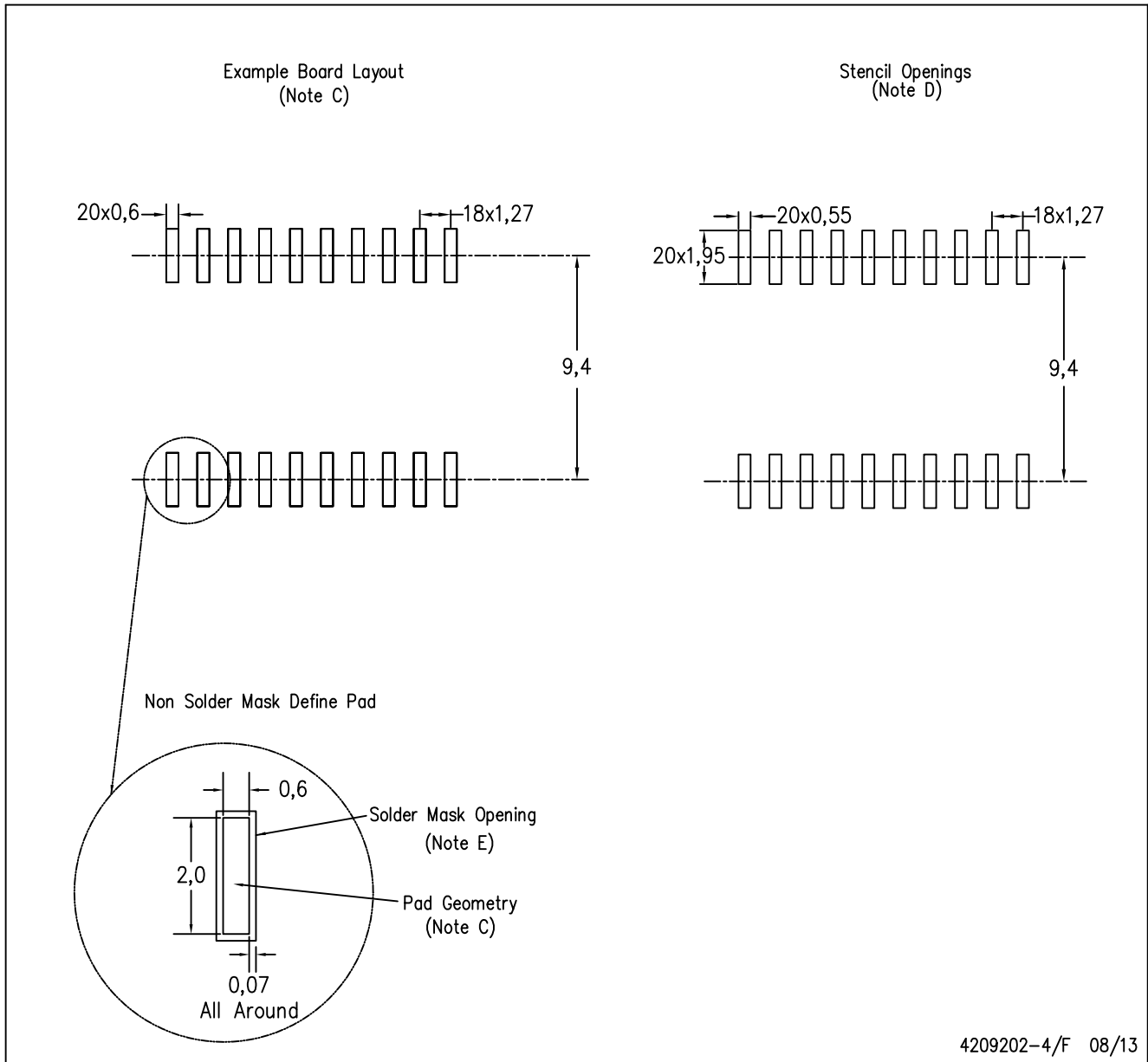

4209202-4/F 08/13

- NOTES:
- A. All linear dimensions are in millimeters.
 - B. This drawing is subject to change without notice.
 - C. Refer to IPC7351 for alternate board design.
 - D. Laser cutting apertures with trapezoidal walls and also rounding corners will offer better paste release. Customers should contact their board assembly site for stencil design recommendations. Refer to IPC-7525
 - E. Customers should contact their board fabrication site for solder mask tolerances between and around signal pads.

PW (R-PDSO-G20)

PLASTIC SMALL OUTLINE

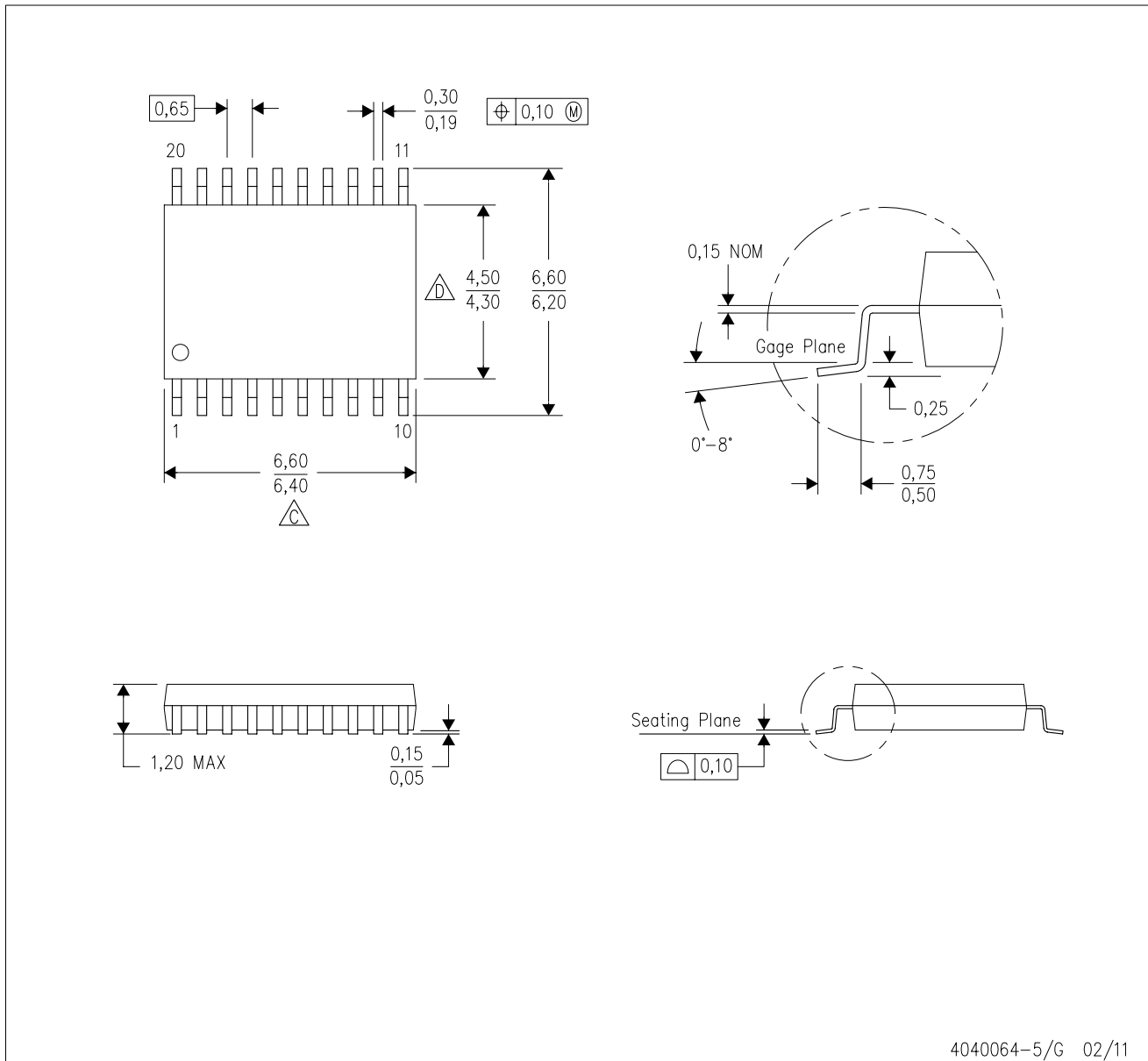

4040064-5/G 02/11

- NOTES:
- A. All linear dimensions are in millimeters. Dimensioning and tolerancing per ASME Y14.5M-1994.
 - B. This drawing is subject to change without notice.
 - C. Body length does not include mold flash, protrusions, or gate burrs. Mold flash, protrusions, or gate burrs shall not exceed 0,15 each side.
 - D. Body width does not include interlead flash. Interlead flash shall not exceed 0,25 each side.
 - E. Falls within JEDEC MO-153

PW (R-PDSO-G20)

PLASTIC SMALL OUTLINE

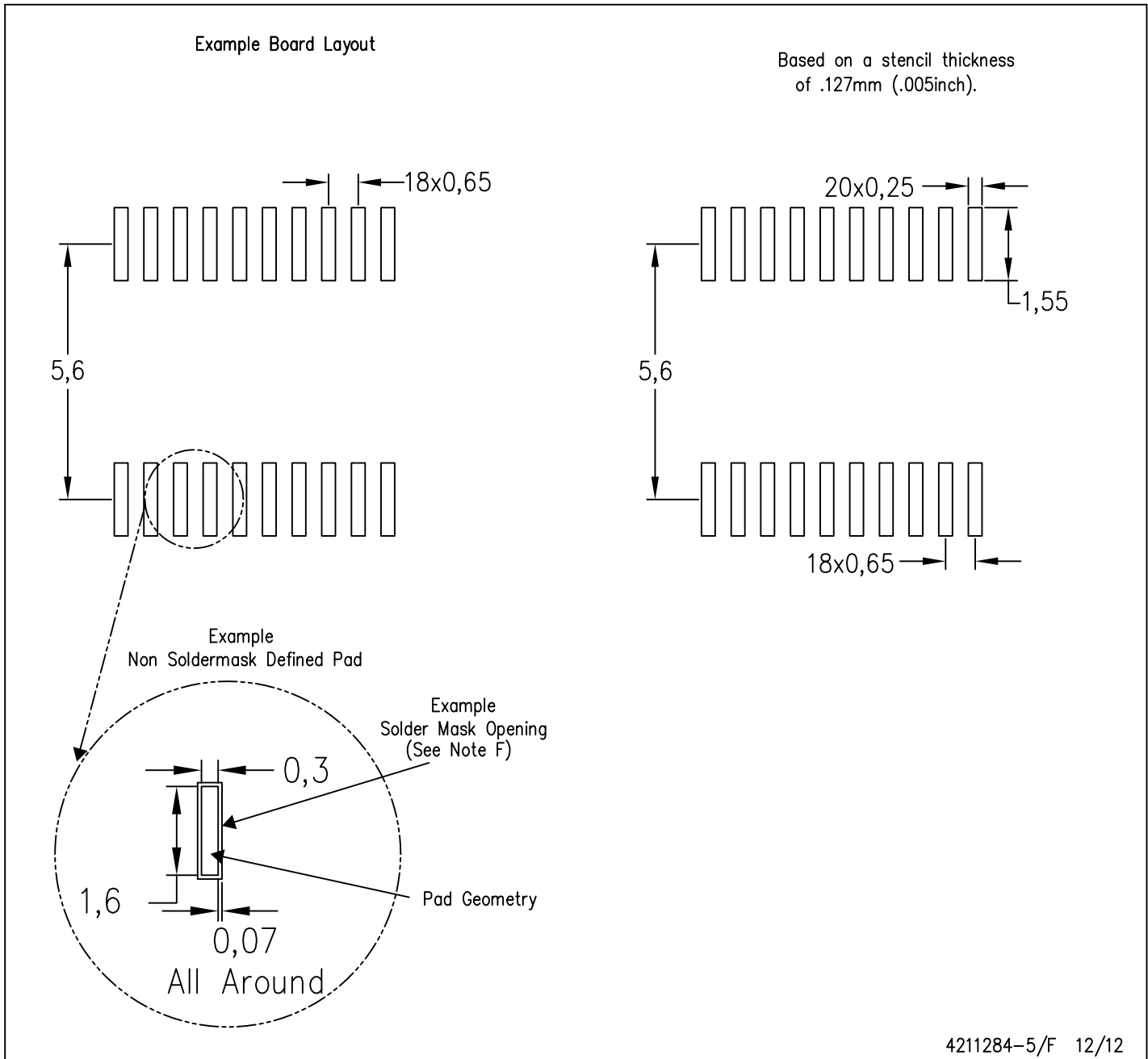

- NOTES:
- A. All linear dimensions are in millimeters.
 - B. This drawing is subject to change without notice.
 - C. Publication IPC-7351 is recommended for alternate design.
 - D. Laser cutting apertures with trapezoidal walls and also rounding corners will offer better paste release. Customers should contact their board assembly site for stencil design recommendations. Refer to IPC-7525 for other stencil recommendations.
 - E. Customers should contact their board fabrication site for solder mask tolerances between and around signal pads.

DB (R-PDSO-G**)

PLASTIC SMALL-OUTLINE

28 PINS SHOWN

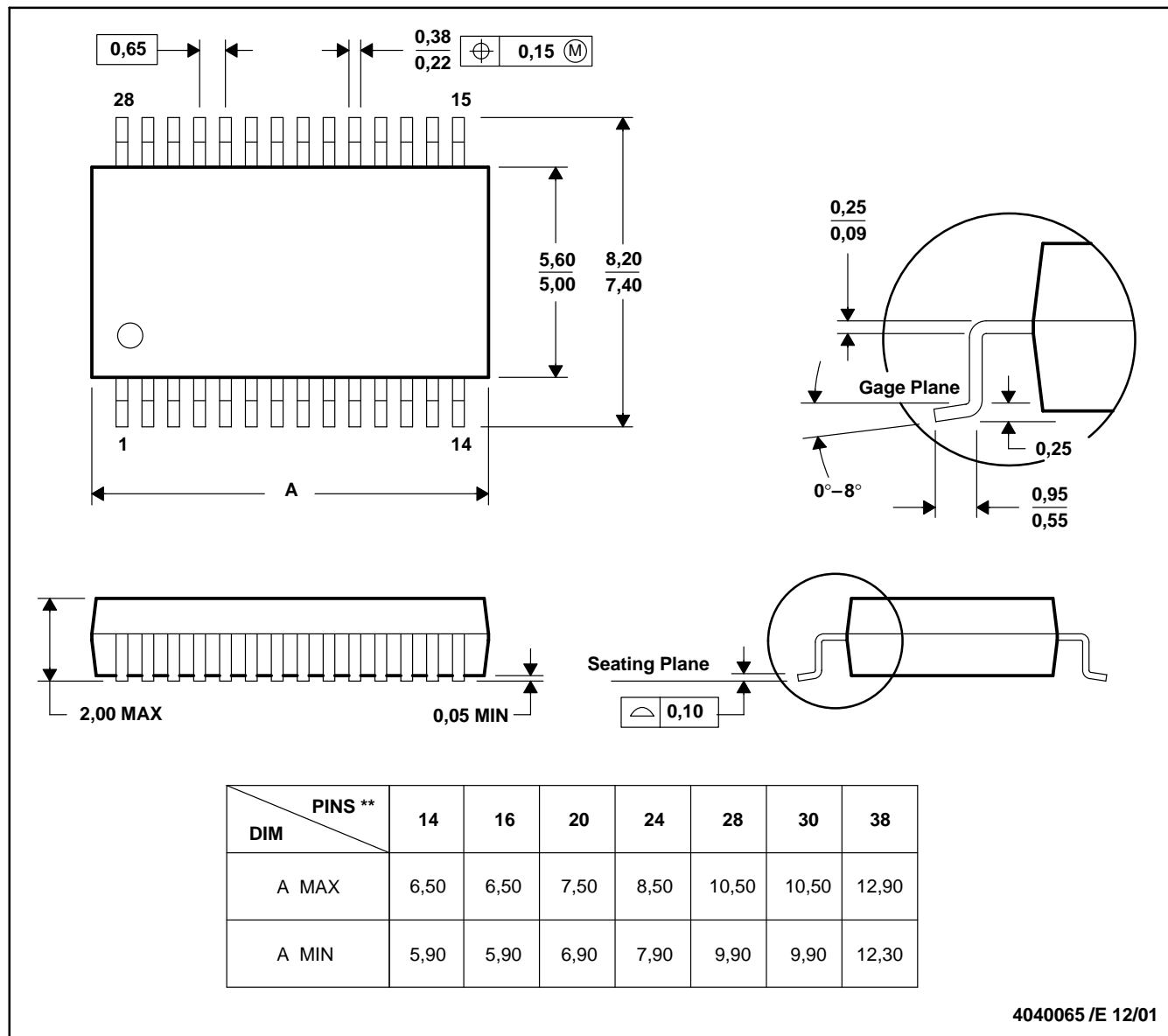

- NOTES: A. All linear dimensions are in millimeters.
 B. This drawing is subject to change without notice.
 C. Body dimensions do not include mold flash or protrusion not to exceed 0,15.
 D. Falls within JEDEC MO-150

IMPORTANT NOTICE

Texas Instruments Incorporated and its subsidiaries (TI) reserve the right to make corrections, enhancements, improvements and other changes to its semiconductor products and services per JESD46, latest issue, and to discontinue any product or service per JESD48, latest issue. Buyers should obtain the latest relevant information before placing orders and should verify that such information is current and complete. All semiconductor products (also referred to herein as "components") are sold subject to TI's terms and conditions of sale supplied at the time of order acknowledgment.

TI warrants performance of its components to the specifications applicable at the time of sale, in accordance with the warranty in TI's terms and conditions of sale of semiconductor products. Testing and other quality control techniques are used to the extent TI deems necessary to support this warranty. Except where mandated by applicable law, testing of all parameters of each component is not necessarily performed.

TI assumes no liability for applications assistance or the design of Buyers' products. Buyers are responsible for their products and applications using TI components. To minimize the risks associated with Buyers' products and applications, Buyers should provide adequate design and operating safeguards.

TI does not warrant or represent that any license, either express or implied, is granted under any patent right, copyright, mask work right, or other intellectual property right relating to any combination, machine, or process in which TI components or services are used. Information published by TI regarding third-party products or services does not constitute a license to use such products or services or a warranty or endorsement thereof. Use of such information may require a license from a third party under the patents or other intellectual property of the third party, or a license from TI under the patents or other intellectual property of TI.

Reproduction of significant portions of TI information in TI data books or data sheets is permissible only if reproduction is without alteration and is accompanied by all associated warranties, conditions, limitations, and notices. TI is not responsible or liable for such altered documentation. Information of third parties may be subject to additional restrictions.

Resale of TI components or services with statements different from or beyond the parameters stated by TI for that component or service voids all express and any implied warranties for the associated TI component or service and is an unfair and deceptive business practice. TI is not responsible or liable for any such statements.

Buyer acknowledges and agrees that it is solely responsible for compliance with all legal, regulatory and safety-related requirements concerning its products, and any use of TI components in its applications, notwithstanding any applications-related information or support that may be provided by TI. Buyer represents and agrees that it has all the necessary expertise to create and implement safeguards which anticipate dangerous consequences of failures, monitor failures and their consequences, lessen the likelihood of failures that might cause harm and take appropriate remedial actions. Buyer will fully indemnify TI and its representatives against any damages arising out of the use of any TI components in safety-critical applications.

In some cases, TI components may be promoted specifically to facilitate safety-related applications. With such components, TI's goal is to help enable customers to design and create their own end-product solutions that meet applicable functional safety standards and requirements. Nonetheless, such components are subject to these terms.

No TI components are authorized for use in FDA Class III (or similar life-critical medical equipment) unless authorized officers of the parties have executed a special agreement specifically governing such use.

Only those TI components which TI has specifically designated as military grade or "enhanced plastic" are designed and intended for use in military/aerospace applications or environments. Buyer acknowledges and agrees that any military or aerospace use of TI components which have **not** been so designated is solely at the Buyer's risk, and that Buyer is solely responsible for compliance with all legal and regulatory requirements in connection with such use.

TI has specifically designated certain components as meeting ISO/TS16949 requirements, mainly for automotive use. In any case of use of non-designated products, TI will not be responsible for any failure to meet ISO/TS16949.

Products

Audio	www.ti.com/audio
Amplifiers	amplifier.ti.com
Data Converters	dataconverter.ti.com
DLP® Products	www.dlp.com
DSP	dsp.ti.com
Clocks and Timers	www.ti.com/clocks
Interface	interface.ti.com
Logic	logic.ti.com
Power Mgmt	power.ti.com
Microcontrollers	microcontroller.ti.com
RFID	www.ti-rfid.com
OMAP Applications Processors	www.ti.com/omap
Wireless Connectivity	www.ti.com/wirelessconnectivity

Applications

Automotive and Transportation	www.ti.com/automotive
Communications and Telecom	www.ti.com/communications
Computers and Peripherals	www.ti.com/computers
Consumer Electronics	www.ti.com/consumer-apps
Energy and Lighting	www.ti.com/energy
Industrial	www.ti.com/industrial
Medical	www.ti.com/medical
Security	www.ti.com/security
Space, Avionics and Defense	www.ti.com/space-avionics-defense
Video and Imaging	www.ti.com/video

TI E2E Community

e2e.ti.com

Looking for pricing, stock, or lifecycle information?

Click below to explore more details on WIN SOURCE:

 [View TRSF3222EIDB](#) on WIN SOURCE

 [Texas Instruments](#) Information

Optimize Your Supply Chain with WIN SOURCE Solutions

-  Global Sourcing Solution
-  Obsolete Management
-  Cost Control Management
-  Shortage Management
-  Alternative Solution
-  Excess Inventory Management