



**THE DATASHEET OF
SN75176BPSRG4**



SNx5176B Differential Bus Transceivers

1 Features

- Bidirectional Transceivers
- Meet or Exceed the Requirements of ANSI Standards TIA/EIA-422-B and TIA/EIA-485-A and ITU Recommendations V.11 and X.27
- Designed for Multipoint Transmission on Long Bus Lines in Noisy Environments
- 3-State Driver and Receiver Outputs
- Individual Driver and Receiver Enables
- Wide Positive and Negative Input/Output Bus Voltage Ranges
- ± 60 -mA Max Driver Output Capability
- Thermal Shutdown Protection
- Driver Positive and Negative Current Limiting
- 12-k Ω Min Receiver Input Impedance
- ± 200 -mV Receiver Input Sensitivity
- 50-mV Typ Receiver Input Hysteresis
- Operate From Single 5-V Supply

2 Applications

- Chemical/Gas Sensors
- Digital Signage
- HMI (Human Machine Interfaces)
- Motor Controls: AC Induction, Brushed and Brushless DC, Low- and High-Voltage, Stepper Motors, and Permanent Magnets
- TETRA Base Stations
- Telecom Towers: Remote Electrical Tilt Units (RET) and Tower Mounted Amplifiers (TMA)
- Weigh Scales
- Wireless Repeaters

3 Description

The SN65176B and SN75176B differential bus transceivers are designed for bidirectional data communication on multipoint bus transmission lines. They are designed for balanced transmission lines and meet ANSI Standards TIA/EIA-422-B and TIA/EIA-485-A and ITU Recommendations V.11 and X.27.

The SN65176B and SN75176B devices combine a 3-state differential line driver and a differential input line receiver, both of which operate from a single 5-V power supply. The driver and receiver have active-high and active-low enables, respectively, that can be connected together externally to function as a direction control. The driver differential outputs and the receiver differential inputs are connected internally to form differential input/output (I/O) bus ports that are designed to offer minimum loading to the bus when the driver is disabled or $V_{CC} = 0$. These ports feature wide positive and negative common-mode voltage ranges, making the device suitable for party-line applications.

The driver is designed for up to 60 mA of sink or source current. The driver features positive and negative current limiting and thermal shutdown for protection from line-fault conditions. Thermal shutdown is designed to occur at a junction temperature of approximately 150°C. The receiver features a minimum input impedance of 12 k Ω , an input sensitivity of ± 200 mV, and a typical input hysteresis of 50 mV.

Device Information⁽¹⁾

PART NUMBER	PACKAGE (PIN)	BODY SIZE (NOM)
SNx5176	SOIC (8)	4.90 mm × 3.91 mm
	PDIP (8)	9.81 mm × 6.35 mm
	SOP (8)	6.20 mm × 5.30 mm

(1) For all available packages, see the orderable addendum at the end of the datasheet.

4 Simplified Schematic

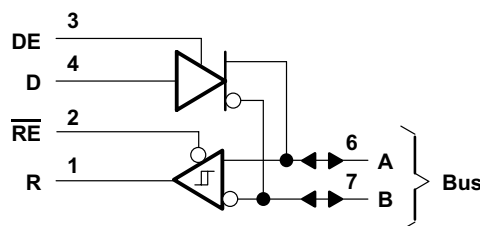

Table of Contents

1 Features	1	9.2 Functional Block Diagram	12
2 Applications	1	9.3 Feature Description	12
3 Description	1	9.4 Device Functional Modes	13
4 Simplified Schematic	1	10 Application and Implementation	14
5 Revision History	2	10.1 Application Information	14
6 Pin Configuration and Functions	3	10.2 Typical Application	14
7 Specifications	4	10.3 System Examples	15
7.1 Absolute Maximum Ratings	4	11 Power Supply Recommendations	16
7.2 Recommended Operating Conditions	4	12 Layout	16
7.3 Thermal Information	4	12.1 Layout Guidelines	16
7.4 Electrical Characteristics – Driver	5	12.2 Layout Example	16
7.5 Electrical Characteristics – Receiver	6	13 Device and Documentation Support	16
7.6 Switching Characteristics – Driver	6	13.1 Related Links	16
7.7 Switching Characteristics – Receiver	6	13.2 Trademarks	16
7.8 Typical Characteristics	7	13.3 Electrostatic Discharge Caution	16
8 Parameter Measurement Information	9	13.4 Glossary	16
9 Detailed Description	12	14 Mechanical, Packaging, and Orderable Information	16
9.1 Overview	12		

5 Revision History

Changes from Revision E (January 2014) to Revision F	Page
<ul style="list-style-type: none"> Added <i>Applications</i>, <i>Device Information</i> table, <i>Pin Functions</i> table, <i>ESD Ratings</i> table, <i>Thermal Information</i> table, <i>Feature Description</i> section, <i>Device Functional Modes</i>, <i>Application and Implementation</i> section, <i>Power Supply Recommendations</i> section, <i>Layout</i> section, <i>Device and Documentation Support</i> section, and <i>Mechanical, Packaging, and Orderable Information</i> section. 	1
<ul style="list-style-type: none"> Moved <i>Typical Characteristics</i> inside of the <i>Specifications</i> section. 	7

Changes from Revision D (April 2003) to Revision E	Page
<ul style="list-style-type: none"> Updated document to new TI data sheet format - no specification changes. 	1
<ul style="list-style-type: none"> Deleted <i>Ordering Information</i> table. 	1
<ul style="list-style-type: none"> Added ESD warning. 	16

6 Pin Configuration and Functions

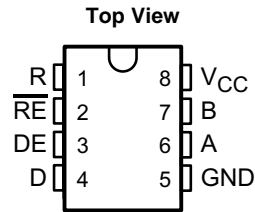

Pin Functions

PIN		TYPE	DESCRIPTION
NAME	NO.		
R	1	O	Logic Data Output from RS-485 Receiver
$\overline{\text{RE}}$	2	I	Receive Enable (active low)
DE	3	I	Driver Enable (active high)
D	4	I	Logic Data Input to RS-485 Driver
GND	5	—	Device Ground Pin
A	6	I/O	RS-422 or RS-485 Data Line
B	7	I/O	RS-422 or RS-485 Data Line
V _{CC}	8	—	Power Input. Connect to 5-V Power Source.

7 Specifications

7.1 Absolute Maximum Ratings

over operating free-air temperature range (unless otherwise noted)⁽¹⁾

		MIN	MAX	UNIT
V _{CC}	Supply voltage ⁽²⁾		7	V
	Voltage range at any bus terminal	-10	15	V
V _I	Enable input voltage		5.5	V
T _J	Operating virtual junction temperature		150	°C
T _{stg}	Storage temperature range	-65	150	°C
	Lead temperature 1,6 mm (1/16 inch) from case for 10 seconds		260	°C

- (1) Stresses beyond those listed under *Absolute Maximum Ratings* may cause permanent damage to the device. These are stress ratings only, and functional operation of the device at these or any other conditions beyond those indicated under *Recommended Operating Conditions* is not implied. Exposure to absolute-maximum-rated conditions for extended periods may affect device reliability.
- (2) All voltage values, except differential input/output bus voltage, are with respect to network ground terminal.

7.2 Recommended Operating Conditions

			MIN	TYP	MAX	UNIT
V _{CC}	Supply voltage		4.75	5	5.25	V
V _I or V _{IC}	Voltage at any bus terminal (separately or common mode)		-7		12	V
V _{IH}	High-level input voltage	D, DE, and \overline{RE}	2			V
V _{IL}	Low-level input voltage	D, DE, and \overline{RE}			0.8	V
V _{ID}	Differential input voltage ⁽¹⁾				±12	V
I _{OH}	High-level output current	Driver			-60	mA
		Receiver			-400	µA
I _{OL}	Low-level output current	Driver			60	mA
		Receiver			8	
T _A	Operating free-air temperature	SN65176B	-40		105	°C
		SN75176B	0		70	

- (1) Differential input/output bus voltage is measured at the non-inverting terminal A, with respect to the inverting terminal B.

7.3 Thermal Information

THERMAL METRIC ⁽¹⁾	SNx5176			UNIT	
	BD	BP	BPS		
	8 PINS				
R _{θJA}	Junction-to-ambient thermal resistance	97	85	95	°C/W

- (1) For more information about traditional and new thermal metrics, see the *IC Package Thermal Metrics* application report ([SPRA953](#)).

7.4 Electrical Characteristics – Driver

over recommended ranges of supply voltage and operating free-air temperature (unless otherwise noted)

PARAMETER		TEST CONDITIONS ⁽¹⁾	MIN	TYP ⁽²⁾	MAX	UNIT
V _{IK}	Input clamp voltage	I _I = -18 mA			-1.5	V
V _O	Output voltage	I _O = 0	0		6	V
V _{OD1}	Differential output voltage	I _O = 0	1.5	3.6	6	V
V _{OD2}	Differential output voltage	R _L = 100 Ω, see Figure 10	½ V _{OD1} or 2 ⁽³⁾			V
		R _L = 54 Ω, see Figure 10	1.5	2.5	5	
V _{OD3}	Differential output voltage	See ⁽⁴⁾	1.5		5	V
Δ V _{OD}	Change in magnitude of differential output voltage ⁽⁵⁾	R _L = 54 Ω or 100 Ω, see Figure 10			±0.2	V
V _{OC}	Common-mode output voltage	R _L = 54 Ω or 100 Ω, see Figure 10	-1		+3	V
Δ V _{OC}	Change in magnitude of common-mode output voltage ⁽⁵⁾	R _L = 54 Ω or 100 Ω, see Figure 10			±0.2	V
I _O	Output current	Output disabled ⁽⁶⁾	V _O = 12 V		1	mA
			V _O = -7 V		-0.8	
I _{IH}	High-level input current	V _I = 2.4 V			20	μA
I _{IL}	Low-level input current	V _I = 0.4 V			-400	μA
I _{OS}	Short-circuit output current	V _O = -7 V			-250	mA
		V _O = 0			-150	
		V _O = V _{CC}			250	
		V _O = 12 V			250	
I _{CC}	Supply current (total package)	No load	Outputs enabled	42	70	mA
			Outputs disabled	26	35	

- (1) The power-off measurement in ANSI Standard TIA/EIA-422-B applies to disabled outputs only and is not applied to combined inputs and outputs.
- (2) All typical values are at V_{CC} = 5 V and T_A = 25°C.
- (3) The minimum V_{OD2} with a 100-Ω load is either ½ V_{OD1} or 2 V, whichever is greater.
- (4) See ANSI Standard TIA/EIA-485-A, Figure 3.5, Test Termination Measurement 2.
- (5) Δ|V_{OD}| and Δ|V_{OC}| are the changes in magnitude of V_{OD} and V_{OC}, respectively, that occur when the input is changed from a high level to a low level.
- (6) This applies for both power on and off; refer to ANSI Standard TIA/EIA-485-A for exact conditions. The TIA/EIA-422-B limit does not apply for a combined driver and receiver terminal.

7.5 Electrical Characteristics – Receiver

over recommended ranges of common-mode input voltage, supply voltage, and operating free-air temperature (unless otherwise noted)

PARAMETER		TEST CONDITIONS	MIN	TYP ⁽¹⁾	MAX	UNIT	
V _{IT+}	Positive-going input threshold voltage	V _O = 2.7 V, I _O = –0.4 mA			0.2	V	
V _{IT–}	Negative-going input threshold voltage	V _O = 0.5 V, I _O = 8 mA	–0.2 ⁽²⁾			V	
V _{hys}	Input hysteresis voltage (V _{IT+} – V _{IT–})			50		mV	
V _{IK}	Enable Input clamp voltage	I _I = –18 mA			–1.5	V	
V _{OH}	High-level output voltage	V _{ID} = 200 mV, I _{OH} = –400 μA, see Figure 11		2.7		V	
V _{OL}	Low-level output voltage	V _{ID} = –200 mV, I _{OL} = 8 mA, see Figure 11			0.45	V	
I _{OZ}	High-impedance-state output current	V _O = 0.4 V to 2.4 V			±20	μA	
I _I	Line input current	Other input = 0 V ⁽³⁾		V _I = 12 V	1	mA	
				V _I = –7 V	–0.8		
I _{IH}	High-level enable input current	V _{IH} = 2.7 V			20	μA	
I _{IL}	Low-level enable input current	V _{IL} = 0.4 V			–100	μA	
r _I	Input resistance	V _I = 12 V		12		kΩ	
I _{OS}	Short-circuit output current			–15	–85	mA	
I _{CC}	Supply current (total package)	No load		Outputs enabled	42	55	mA
				Outputs disabled	26	35	

(1) All typical values are at V_{CC} = 5 V, T_A = 25°C.

(2) The algebraic convention, in which the less positive (more negative) limit is designated minimum, is used in this data sheet for common-mode input voltage and threshold voltage levels only.

(3) This applies for both power on and power off. Refer to EIA Standard TIA/EIA-485-A for exact conditions.

7.6 Switching Characteristics – Driver

V_{CC} = 5 V, R_L = 110 Ω, T_A = 25°C (unless otherwise noted)

PARAMETER		TEST CONDITIONS	MIN	TYP	MAX	UNIT
t _{d(OD)}	Differential-output delay time	R _L = 54 Ω, see Figure 12		15	22	ns
t _{t(OD)}	Differential-output transition time	R _L = 54 Ω, see Figure 12		20	30	ns
t _{pZH}	Output enable time to high level	See Figure 13		85	120	ns
t _{pZL}	Output enable time to low level	See Figure 14		40	60	ns
t _{pHZ}	Output disable time from high level	See Figure 13		150	250	ns
t _{pLZ}	Output disable time from low level	See Figure 14		20	30	ns

7.7 Switching Characteristics – Receiver

V_{CC} = 5 V, C_L = 15 pF, T_A = 25°C

PARAMETER		TEST CONDITIONS	MIN	TYP	MAX	UNIT
t _{PLH}	Propagation delay time, low- to high-level output	V _{ID} = 0 to 3 V, see Figure 15		21	35	ns
t _{PHL}	Propagation delay time, high- to low-level output			23	35	
t _{pZH}	Output enable time to high level	See Figure 16		10	20	ns
t _{pZL}	Output enable time to low level			12	20	
t _{PHZ}	Output disable time from high level	See Figure 16		20	35	ns
t _{PLZ}	Output disable time from low level			17	25	

7.8 Typical Characteristics

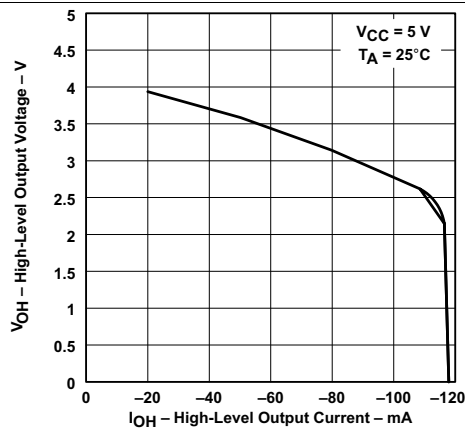

Figure 1. Driver High-Level Output Voltage vs High-Level Output Current

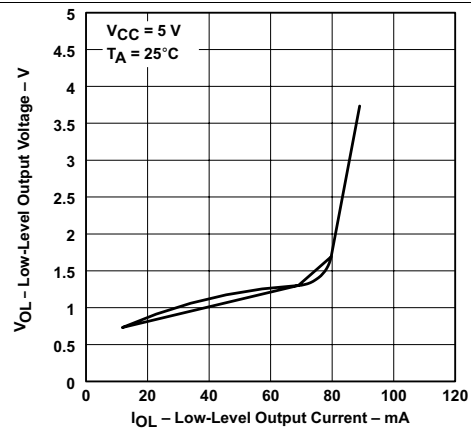

Figure 2. Driver Low-Level Output Voltage vs Low-Level Output Current

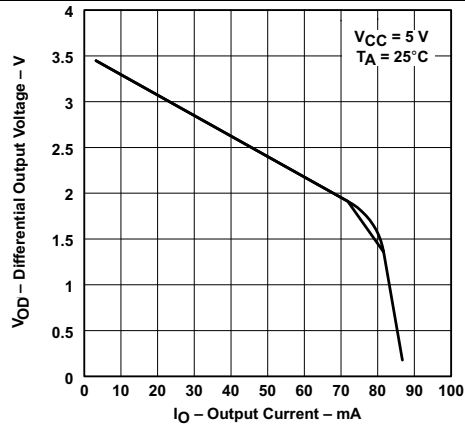

Figure 3. Driver Differential Output Voltage vs Output Current

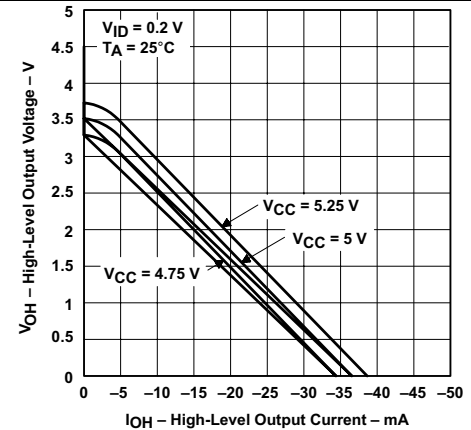
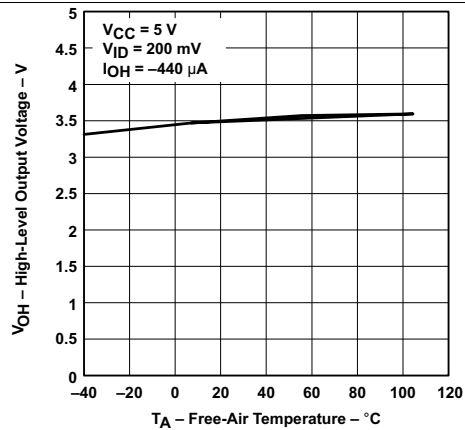

Figure 4. Receiver High-Level Output Voltage vs High-Level Output Current



Only the 0°C to 70°C portion of the curve applies to the SN75176B device.

Figure 5. Receiver High-Level Output Voltage vs Free-Air Temperature

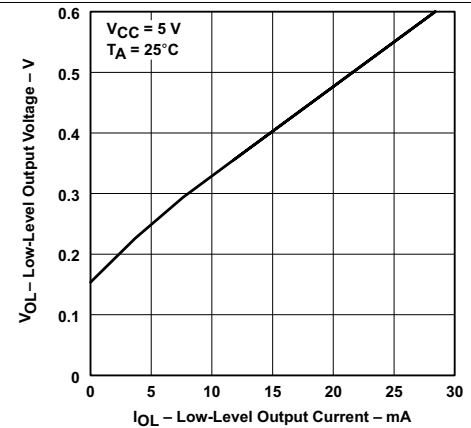

Figure 6. Receiver Low-Level Output Voltage vs Low-Level Output Current

Typical Characteristics (continued)

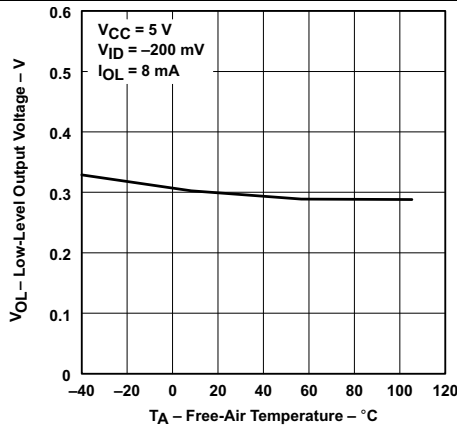

Figure 7. Receiver Low-Level Output Voltage vs Free-Air Temperature

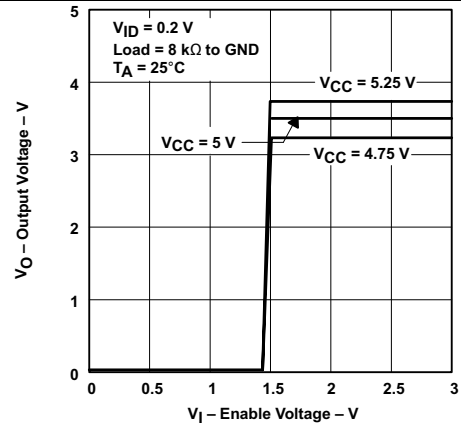

Figure 8. Receiver Output Voltage vs Enable Voltage

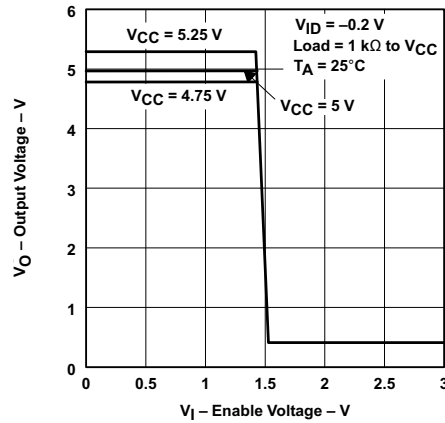

Figure 9. Receiver Output Voltage vs Enable Voltage

8 Parameter Measurement Information

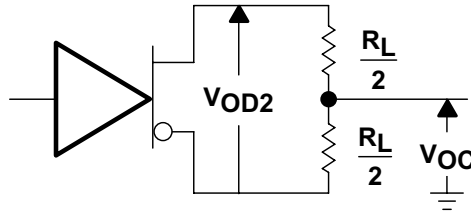

Figure 10. Driver V_{OD} and V_{OC}

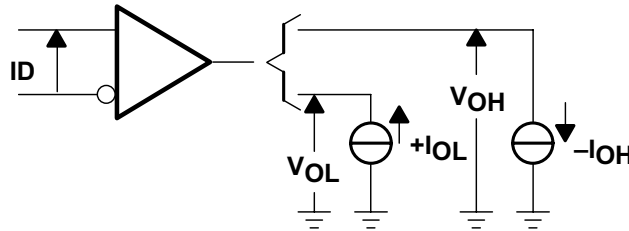
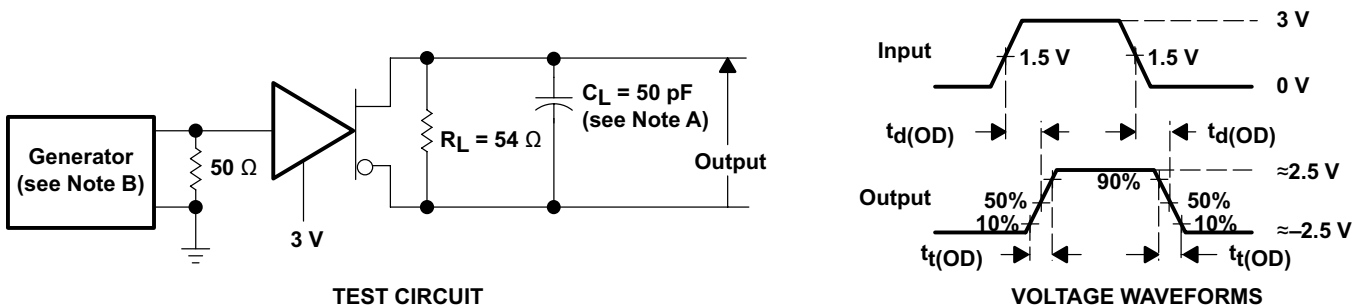

Figure 11. Receiver V_{OH} and V_{OL}



TEST CIRCUIT

VOLTAGE WAVEFORMS

- A. C_L includes probe and jig capacitance.
- B. The input pulse is supplied by a generator having the following characteristics: PRR ≤ 1 MHz, 50% duty cycle, $t_r \leq 6$ ns, $t_f \leq 6$ ns, $Z_O = 50 \Omega$.

Figure 12. Driver Test Circuit and Voltage Waveforms

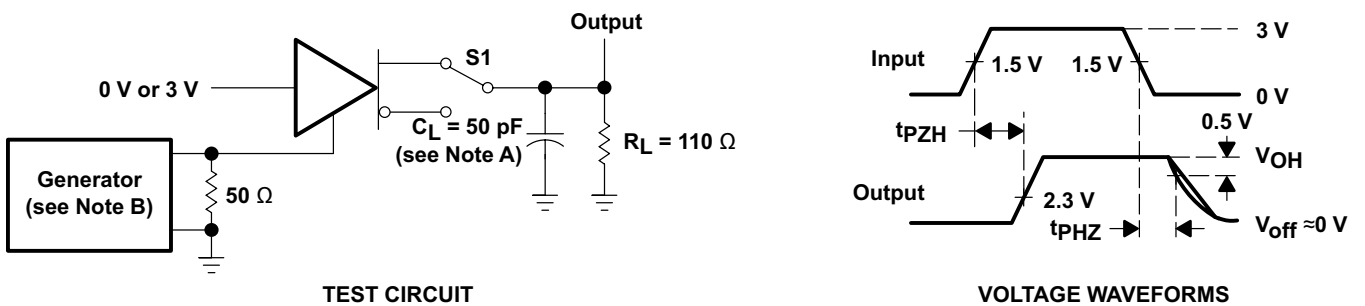

TEST CIRCUIT

VOLTAGE WAVEFORMS

- A. C_L includes probe and jig capacitance.
- B. The input pulse is supplied by a generator having the following characteristics: PRR ≤ 1 MHz, 50% duty cycle, $t_r \leq 6$ ns, $t_f \leq 6$ ns, $Z_O = 50 \Omega$.

Figure 13. Driver Test Circuit and Voltage Waveforms

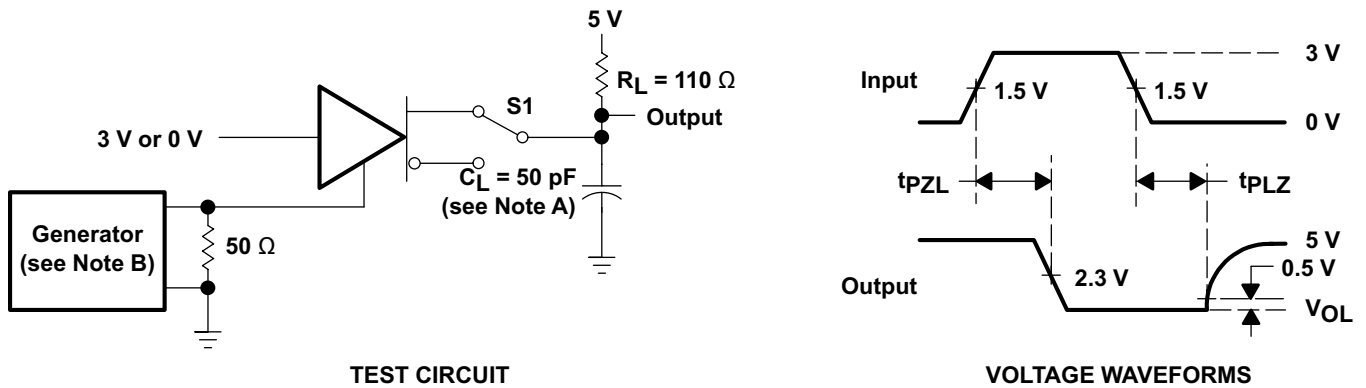
Parameter Measurement Information (continued)

- A. C_L includes probe and jig capacitance.
- B. The input pulse is supplied by a generator having the following characteristics: PRR ≤ 1 MHz, 50% duty cycle, $t_r \leq 6$ ns, $t_f \leq 6$ ns, $Z_O = 50 \Omega$.

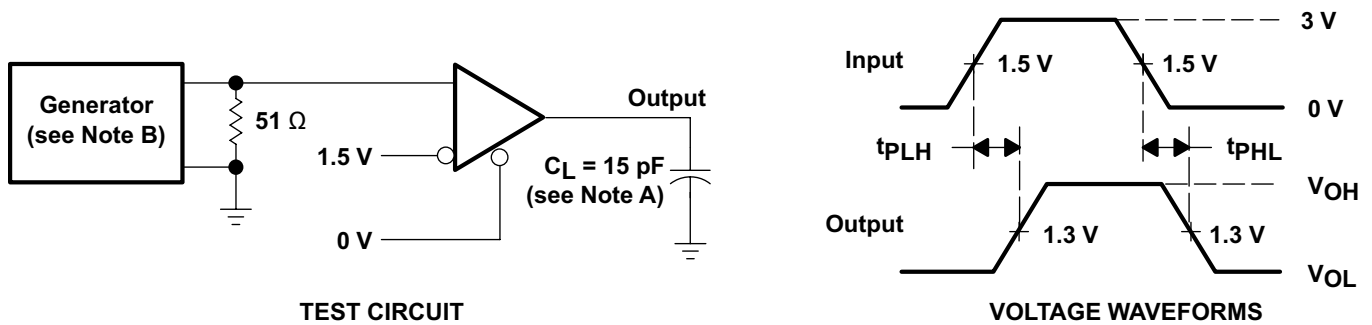
Figure 14. Driver Test Circuit and Voltage Waveforms

- A. C_L includes probe and jig capacitance.
- B. The input pulse is supplied by a generator having the following characteristics: PRR ≤ 1 MHz, 50% duty cycle, $t_r \leq 6$ ns, $t_f \leq 6$ ns, $Z_O = 50 \Omega$.

Figure 15. Receiver Test Circuit and Voltage Waveforms

Parameter Measurement Information (continued)

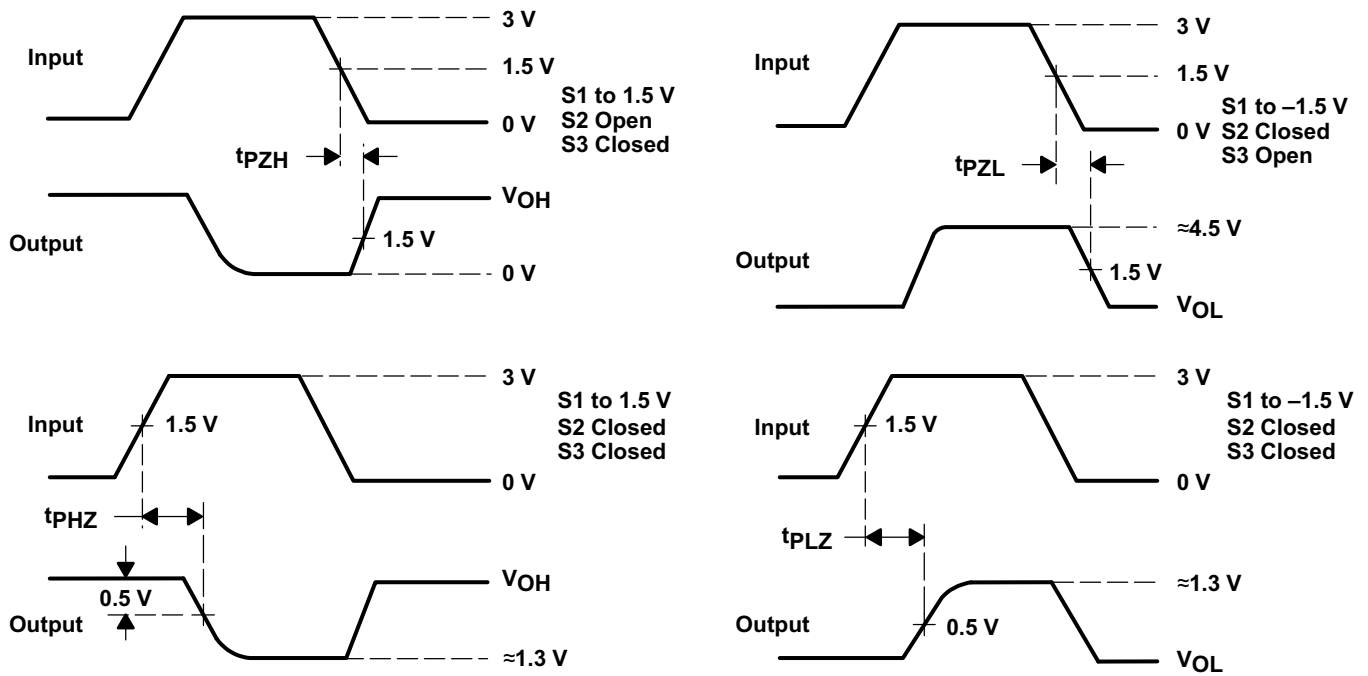
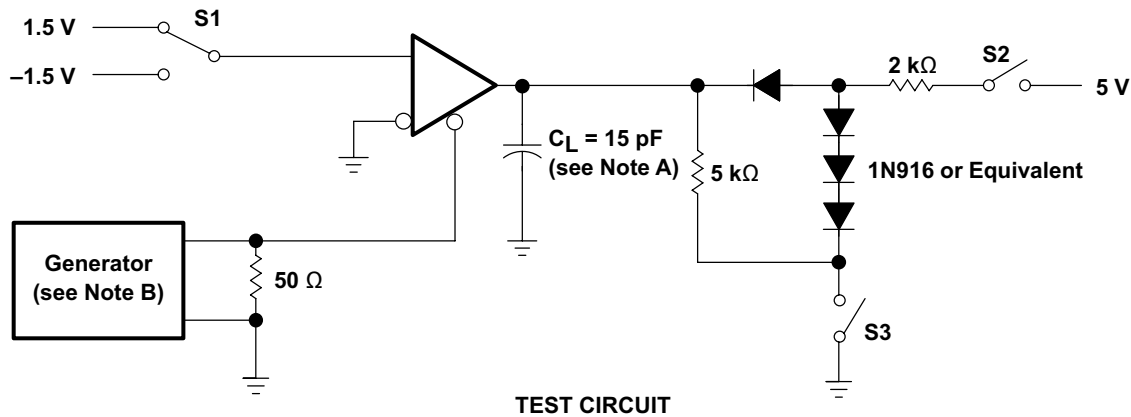

- A. C_L includes probe and jig capacitance.
- B. The input pulse is supplied by a generator having the following characteristics: PRR ≤ 1 MHz, 50% duty cycle, $t_r \leq 6$ ns, $t_f \leq 6$ ns, $Z_O = 50 \Omega$.

Figure 16. Receiver Test Circuit and Voltage Waveforms

9 Detailed Description

9.1 Overview

The SN65176B and SN75176B differential bus transceivers are integrated circuits designed for bidirectional data communication on multipoint bus transmission lines. They are designed for balanced transmission lines and meet ANSI Standards TIA/EIA-422-B and TIA/EIA-485-A and ITU Recommendations V.11 and X.27.

The SN65176B and SN75176B devices combine a 3-state differential line driver and a differential input line receiver, both of which operate from a single 5-V power supply. The driver and receiver have active-high and active-low enables, respectively, that can be connected together externally to function as a direction control. The driver differential outputs and the receiver differential inputs are connected internally to form differential input/output (I/O) bus ports that are designed to offer minimum loading to the bus when the driver is disabled or $V_{CC} = 0$. These ports feature wide positive and negative common-mode voltage ranges, making the device suitable for party-line applications.

The driver is designed for up to 60 mA of sink or source current. The driver features positive and negative current limiting and thermal shutdown for protection from line-fault conditions. Thermal shutdown is designed to occur at a junction temperature of approximately 150°C. The receiver features a minimum input impedance of 12 k Ω , an input sensitivity of ± 200 mV, and a typical input hysteresis of 50 mV.

The SN65176B and SN75176B devices can be used in transmission-line applications employing the SN75172 and SN75174 quadruple differential line drivers and SN75173 and SN75175 quadruple differential line receivers.

9.2 Functional Block Diagram

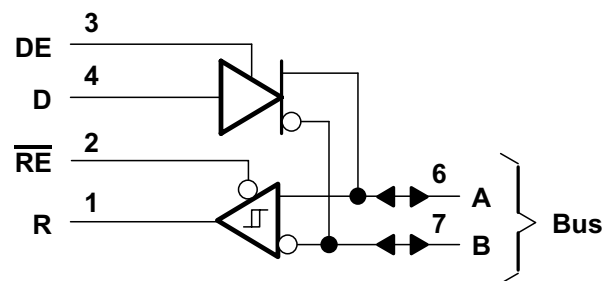

9.3 Feature Description

9.3.1 Driver

The driver converts a TTL logic signal level to RS-422 and RS-485 compliant differential output. The TTL logic input, DE pin, can be used to turn the driver on and off.

Table 1. Driver Function Table⁽¹⁾

INPUT D	ENABLE DE	DIFFERENTIAL OUTPUTS	
		A	B
H	H	H	L
L	H	L	H
X	L	Z	Z

- (1) H = high level,
L = low level,
X = irrelevant,
Z = high impedance (off)

9.3.2 Receiver

The receiver converts a RS-422 or RS-485 differential input voltage to a TTL logic level output. The TTL logic input, RE pin, can be used to turn the receiver logic output on and off.

Table 2. Receiver Function Table⁽¹⁾

DIFFERENTIAL INPUTS A–B	ENABLE RE	OUTPUT R
$V_{ID} \geq 0.2 \text{ V}$	L	H
$-0.2 \text{ V} < V_{ID} < 0.2 \text{ V}$	L	U
$V_{ID} \leq -0.2 \text{ V}$	L	L
X	H	Z
Open	L	U

- (1) H = high level,
 L = low level,
 U = unknown,
 Z = high impedance (off)

9.4 Device Functional Modes

9.4.1 Device Powered

Both the driver and receiver can be individually enabled or disabled in any combination. DE and $\overline{\text{RE}}$ can be connected together for a single port direction control bit.

9.4.2 Device Unpowered

The driver differential outputs and the receiver differential inputs are connected internally to form differential input/output (I/O) bus ports that are designed to offer minimum loading to the bus when the driver is disabled or $V_{CC} = 0$.

9.4.3 Symbol Cross Reference

Table 3. Symbol Equivalents

DATA SHEET PARAMETER	TIA/EIA-422-B	TIA/EIA-485-A
V_O	V_{Oa}, V_{Ob}	V_{Oa}, V_{Ob}
$ V_{OD1} $	V_o	V_o
$ V_{OD2} $	$V_t @_{L} = 100 \Omega$	$V_t @_{L} = 54 \Omega$
$ V_{OD3} $		V_t (test termination measurement 2)
$\Delta V_{OD} $	$ V_t - \overline{V}_t $	$ V_t - \overline{V}_t $
V_{OC}	$ V_{os} $	$ V_{os} $
$\Delta V_{OC} $	$ V_{os} - \overline{V}_{os} $	$ V_{os} - \overline{V}_{os} $
I_{OS}	$ I_{sa} , I_{sb} $	
I_O	$ I_{xa} , I_{xb} $	I_{ia}, I_{ib}

10 Application and Implementation

NOTE

Information in the following applications sections is not part of the TI component specification, and TI does not warrant its accuracy or completeness. TI's customers are responsible for determining suitability of components for their purposes. Customers should validate and test their design implementation to confirm system functionality.

10.1 Application Information

The device can be used in RS-485 and RS-422 physical layer communications.

10.2 Typical Application

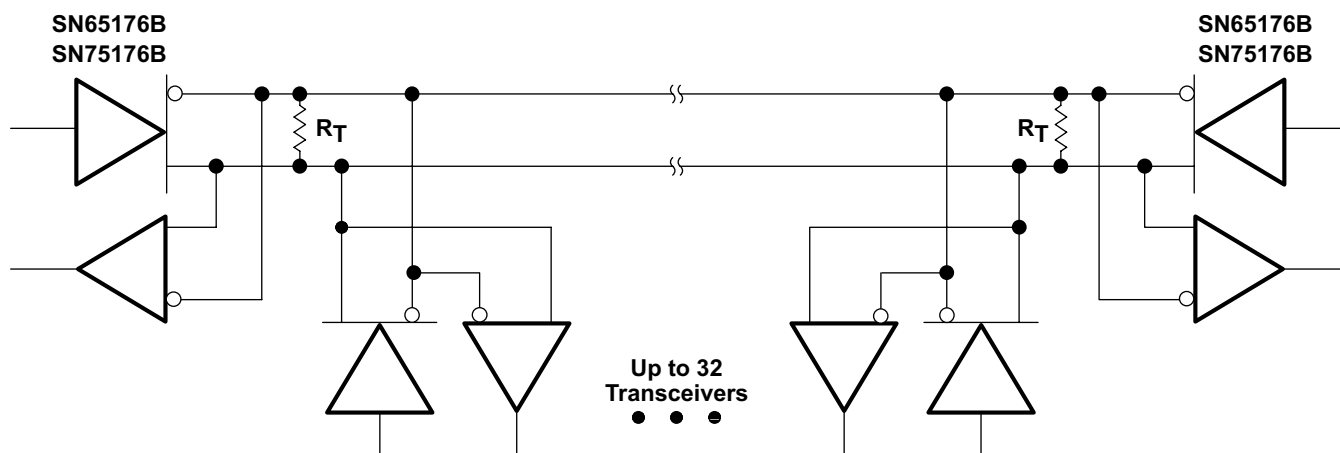

The line should be terminated at both ends in its characteristic impedance ($R_T = Z_0$). Stub lengths off the main line should be kept as short as possible.

Figure 17. Typical RS-485 Application Circuit

10.2.1 Design Requirements

- 5-V power source
- RS-485 bus operating at 10 Mbps or less
- Connector that ensures the correct polarity for port pins
- External fail safe implementation

10.2.2 Detailed Design Procedure

- Place the device close to bus connector to keep traces (stub) short to prevent adding reflections to the bus line
- If desired, add external fail-safe biasing to ensure +200 mV on the A-B port.

Typical Application (continued)

10.2.3 Application Curves

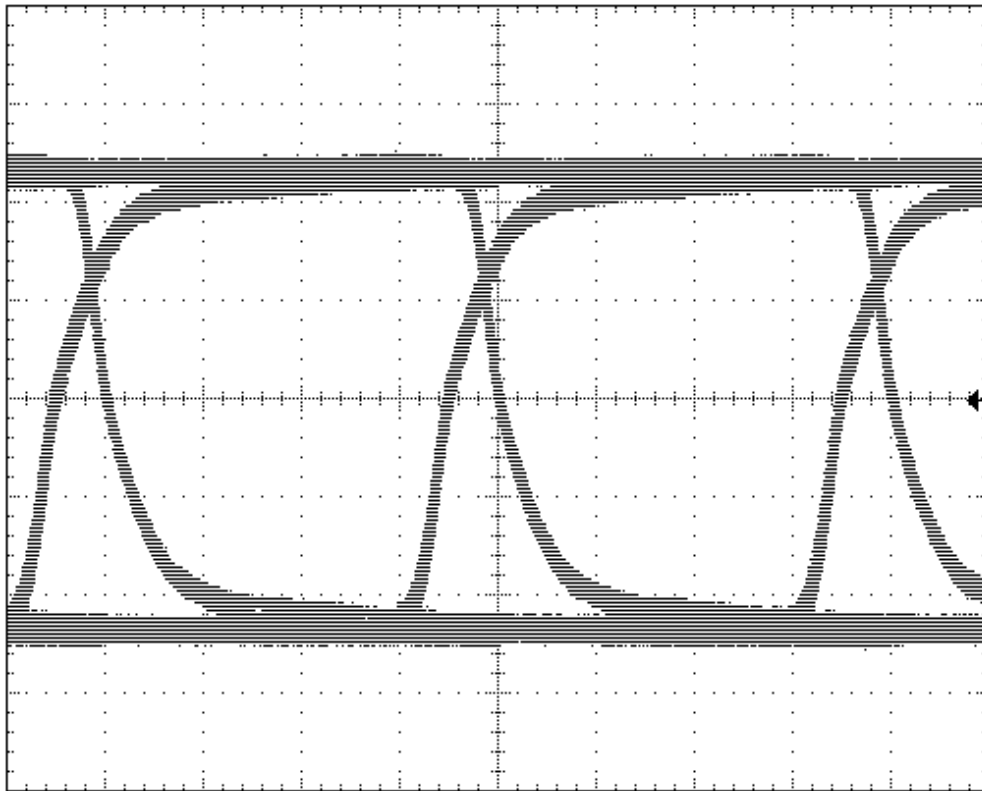

Figure 18. Eye Diagram for 10-Mbits/s over 100 feet of standard CAT-5E cable
120-Ω Termination at both ends. Scale is 1V per division and 25nS per division

10.3 System Examples

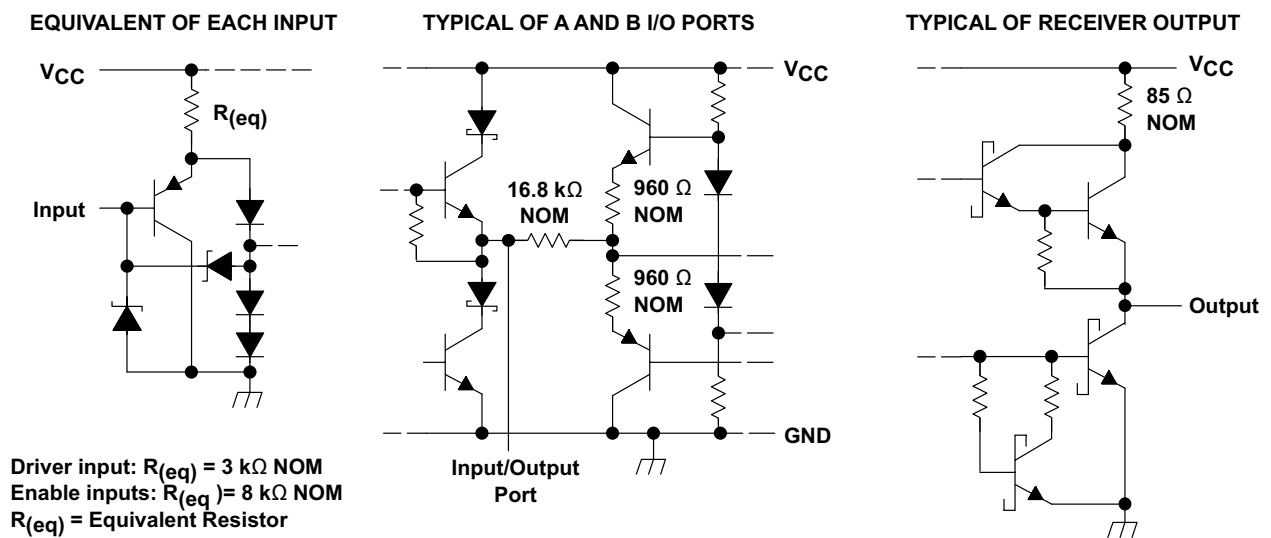

Figure 19. Schematics of Inputs and Outputs

11 Power Supply Recommendations

Power supply should be 5V with a tolerance less than 10%

12 Layout

12.1 Layout Guidelines

Traces from device pins A and B to connector must be short and capable of 250 mA maximum current.

12.2 Layout Example

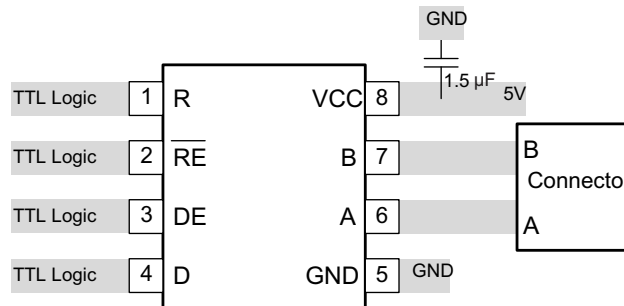

Layout Diagram

13 Device and Documentation Support

13.1 Related Links

The table below lists quick access links. Categories include technical documents, support and community resources, tools and software, and quick access to sample or buy.

Table 4. Related Links

PARTS	PRODUCT FOLDER	SAMPLE & BUY	TECHNICAL DOCUMENTS	TOOLS & SOFTWARE	SUPPORT & COMMUNITY
SN65176B	Click here	Click here	Click here	Click here	Click here
SN75176B	Click here	Click here	Click here	Click here	Click here

13.2 Trademarks

All trademarks are the property of their respective owners.

13.3 Electrostatic Discharge Caution



These devices have limited built-in ESD protection. The leads should be shorted together or the device placed in conductive foam during storage or handling to prevent electrostatic damage to the MOS gates.

13.4 Glossary

[SLYZ022](#) — TI Glossary.

This glossary lists and explains terms, acronyms, and definitions.

14 Mechanical, Packaging, and Orderable Information

The following pages include mechanical, packaging, and orderable information. This information is the most current data available for the designated devices. This data is subject to change without notice and revision of this document. For browser-based versions of this data sheet, refer to the left-hand navigation.

PACKAGING INFORMATION

Orderable Device	Status (1)	Package Type	Package Drawing	Pins	Package Qty	Eco Plan (2)	Lead/Ball Finish (6)	MSL Peak Temp (3)	Op Temp (°C)	Device Marking (4/5)	Samples
SN65176BD	ACTIVE	SOIC	D	8	75	Green (RoHS & no Sb/Br)	CU NIPDAU	Level-1-260C-UNLIM	-40 to 105	65176B	Samples
SN65176BDG4	ACTIVE	SOIC	D	8	75	Green (RoHS & no Sb/Br)	CU NIPDAU	Level-1-260C-UNLIM	-40 to 105	65176B	Samples
SN65176BDR	ACTIVE	SOIC	D	8	2500	Green (RoHS & no Sb/Br)	CU NIPDAU	Level-1-260C-UNLIM	-40 to 105	65176B	Samples
SN65176BDRE4	ACTIVE	SOIC	D	8	2500	Green (RoHS & no Sb/Br)	CU NIPDAU	Level-1-260C-UNLIM	-40 to 105	65176B	Samples
SN65176BDRG4	ACTIVE	SOIC	D	8	2500	Green (RoHS & no Sb/Br)	CU NIPDAU	Level-1-260C-UNLIM	-40 to 105	65176B	Samples
SN65176BP	ACTIVE	PDIP	P	8	50	Green (RoHS & no Sb/Br)	CU NIPDAU	N / A for Pkg Type	-40 to 105	SN65176BP	Samples
SN75176BD	ACTIVE	SOIC	D	8	75	Green (RoHS & no Sb/Br)	CU NIPDAU	Level-1-260C-UNLIM	0 to 70	75176B	Samples
SN75176BDE4	ACTIVE	SOIC	D	8	75	Green (RoHS & no Sb/Br)	CU NIPDAU	Level-1-260C-UNLIM	0 to 70	75176B	Samples
SN75176BDG4	ACTIVE	SOIC	D	8	75	Green (RoHS & no Sb/Br)	CU NIPDAU	Level-1-260C-UNLIM	0 to 70	75176B	Samples
SN75176BDR	ACTIVE	SOIC	D	8	2500	Green (RoHS & no Sb/Br)	CU NIPDAU	Level-1-260C-UNLIM	0 to 70	75176B	Samples
SN75176BDRE4	ACTIVE	SOIC	D	8	2500	Green (RoHS & no Sb/Br)	CU NIPDAU	Level-1-260C-UNLIM	0 to 70	75176B	Samples
SN75176BDRG4	ACTIVE	SOIC	D	8	2500	Green (RoHS & no Sb/Br)	CU NIPDAU	Level-1-260C-UNLIM	0 to 70	75176B	Samples
SN75176BP	ACTIVE	PDIP	P	8	50	Pb-Free (RoHS)	CU NIPDAU	N / A for Pkg Type	0 to 70	SN75176BP	Samples
SN75176BPE4	ACTIVE	PDIP	P	8	50	Pb-Free (RoHS)	CU NIPDAU	N / A for Pkg Type	0 to 70	SN75176BP	Samples
SN75176BPSR	ACTIVE	SO	PS	8	2000	Green (RoHS & no Sb/Br)	CU NIPDAU	Level-1-260C-UNLIM	0 to 70	A176B	Samples
SN75176BPSRG4	ACTIVE	SO	PS	8	2000	Green (RoHS & no Sb/Br)	CU NIPDAU	Level-1-260C-UNLIM	0 to 70	A176B	Samples

(1) The marketing status values are defined as follows:
ACTIVE: Product device recommended for new designs.

LIFEBUY: TI has announced that the device will be discontinued, and a lifetime-buy period is in effect.

NRND: Not recommended for new designs. Device is in production to support existing customers, but TI does not recommend using this part in a new design.

PREVIEW: Device has been announced but is not in production. Samples may or may not be available.

OBSOLETE: TI has discontinued the production of the device.

⁽²⁾ **RoHS:** TI defines "RoHS" to mean semiconductor products that are compliant with the current EU RoHS requirements for all 10 RoHS substances, including the requirement that RoHS substance do not exceed 0.1% by weight in homogeneous materials. Where designed to be soldered at high temperatures, "RoHS" products are suitable for use in specified lead-free processes. TI may reference these types of products as "Pb-Free".

RoHS Exempt: TI defines "RoHS Exempt" to mean products that contain lead but are compliant with EU RoHS pursuant to a specific EU RoHS exemption.

Green: TI defines "Green" to mean the content of Chlorine (Cl) and Bromine (Br) based flame retardants meet JS709B low halogen requirements of ≤ 1000 ppm threshold. Antimony trioxide based flame retardants must also meet the ≤ 1000 ppm threshold requirement.

⁽³⁾ MSL, Peak Temp. - The Moisture Sensitivity Level rating according to the JEDEC industry standard classifications, and peak solder temperature.

⁽⁴⁾ There may be additional marking, which relates to the logo, the lot trace code information, or the environmental category on the device.

⁽⁵⁾ Multiple Device Markings will be inside parentheses. Only one Device Marking contained in parentheses and separated by a "~" will appear on a device. If a line is indented then it is a continuation of the previous line and the two combined represent the entire Device Marking for that device.

⁽⁶⁾ Lead/Ball Finish - Orderable Devices may have multiple material finish options. Finish options are separated by a vertical ruled line. Lead/Ball Finish values may wrap to two lines if the finish value exceeds the maximum column width.

Important Information and Disclaimer: The information provided on this page represents TI's knowledge and belief as of the date that it is provided. TI bases its knowledge and belief on information provided by third parties, and makes no representation or warranty as to the accuracy of such information. Efforts are underway to better integrate information from third parties. TI has taken and continues to take reasonable steps to provide representative and accurate information but may not have conducted destructive testing or chemical analysis on incoming materials and chemicals. TI and TI suppliers consider certain information to be proprietary, and thus CAS numbers and other limited information may not be available for release.

In no event shall TI's liability arising out of such information exceed the total purchase price of the TI part(s) at issue in this document sold by TI to Customer on an annual basis.

TAPE AND REEL INFORMATION

QUADRANT ASSIGNMENTS FOR PIN 1 ORIENTATION IN TAPE

*All dimensions are nominal

Device	Package Type	Package Drawing	Pins	SPQ	Reel Diameter (mm)	Reel Width W1 (mm)	A0 (mm)	B0 (mm)	K0 (mm)	P1 (mm)	W (mm)	Pin1 Quadrant
SN65176BDR	SOIC	D	8	2500	330.0	12.4	6.4	5.2	2.1	8.0	12.0	Q1
SN65176BDRG4	SOIC	D	8	2500	330.0	12.4	6.4	5.2	2.1	8.0	12.0	Q1
SN75176BDR	SOIC	D	8	2500	330.0	12.4	6.4	5.2	2.1	8.0	12.0	Q1
SN75176BDRG4	SOIC	D	8	2500	330.0	12.4	6.4	5.2	2.1	8.0	12.0	Q1

TAPE AND REEL BOX DIMENSIONS

*All dimensions are nominal

Device	Package Type	Package Drawing	Pins	SPQ	Length (mm)	Width (mm)	Height (mm)
SN65176BDR	SOIC	D	8	2500	340.5	338.1	20.6
SN65176BDRG4	SOIC	D	8	2500	340.5	338.1	20.6
SN75176BDR	SOIC	D	8	2500	340.5	338.1	20.6
SN75176BDRG4	SOIC	D	8	2500	340.5	338.1	20.6



D0008A

PACKAGE OUTLINE

SOIC - 1.75 mm max height

SMALL OUTLINE INTEGRATED CIRCUIT



4214825/C 02/2019

NOTES:

- Linear dimensions are in inches [millimeters]. Dimensions in parenthesis are for reference only. Controlling dimensions are in inches. Dimensioning and tolerancing per ASME Y14.5M.
- This drawing is subject to change without notice.
- This dimension does not include mold flash, protrusions, or gate burrs. Mold flash, protrusions, or gate burrs shall not exceed $.006$ [0.15] per side.
- This dimension does not include interlead flash.
- Reference JEDEC registration MS-012, variation AA.

EXAMPLE BOARD LAYOUT

D0008A

SOIC - 1.75 mm max height

SMALL OUTLINE INTEGRATED CIRCUIT



LAND PATTERN EXAMPLE
EXPOSED METAL SHOWN
SCALE:8X



SOLDER MASK DETAILS

4214825/C 02/2019

NOTES: (continued)

- 6. Publication IPC-7351 may have alternate designs.
- 7. Solder mask tolerances between and around signal pads can vary based on board fabrication site.

EXAMPLE STENCIL DESIGN

D0008A

SOIC - 1.75 mm max height

SMALL OUTLINE INTEGRATED CIRCUIT



SOLDER PASTE EXAMPLE
BASED ON .005 INCH [0.125 MM] THICK STENCIL
SCALE:8X

4214825/C 02/2019

NOTES: (continued)

8. Laser cutting apertures with trapezoidal walls and rounded corners may offer better paste release. IPC-7525 may have alternate design recommendations.
9. Board assembly site may have different recommendations for stencil design.

MECHANICAL DATA

PS (R-PDSO-G8)

PLASTIC SMALL-OUTLINE PACKAGE



- NOTES:
- A. All linear dimensions are in millimeters.
 - B. This drawing is subject to change without notice.
 - C. Body dimensions do not include mold flash or protrusion, not to exceed 0,15.

P (R-PDIP-T8)

PLASTIC DUAL-IN-LINE PACKAGE



- NOTES:
- A. All linear dimensions are in inches (millimeters).
 - B. This drawing is subject to change without notice.
 - C. Falls within JEDEC MS-001 variation BA.

IMPORTANT NOTICE AND DISCLAIMER

TI PROVIDES TECHNICAL AND RELIABILITY DATA (INCLUDING DATASHEETS), DESIGN RESOURCES (INCLUDING REFERENCE DESIGNS), APPLICATION OR OTHER DESIGN ADVICE, WEB TOOLS, SAFETY INFORMATION, AND OTHER RESOURCES "AS IS" AND WITH ALL FAULTS, AND DISCLAIMS ALL WARRANTIES, EXPRESS AND IMPLIED, INCLUDING WITHOUT LIMITATION ANY IMPLIED WARRANTIES OF MERCHANTABILITY, FITNESS FOR A PARTICULAR PURPOSE OR NON-INFRINGEMENT OF THIRD PARTY INTELLECTUAL PROPERTY RIGHTS.

These resources are intended for skilled developers designing with TI products. You are solely responsible for (1) selecting the appropriate TI products for your application, (2) designing, validating and testing your application, and (3) ensuring your application meets applicable standards, and any other safety, security, or other requirements. These resources are subject to change without notice. TI grants you permission to use these resources only for development of an application that uses the TI products described in the resource. Other reproduction and display of these resources is prohibited. No license is granted to any other TI intellectual property right or to any third party intellectual property right. TI disclaims responsibility for, and you will fully indemnify TI and its representatives against, any claims, damages, costs, losses, and liabilities arising out of your use of these resources.

TI's products are provided subject to TI's Terms of Sale (www.ti.com/legal/termsofsale.html) or other applicable terms available either on ti.com or provided in conjunction with such TI products. TI's provision of these resources does not expand or otherwise alter TI's applicable warranties or warranty disclaimers for TI products.

Mailing Address: Texas Instruments, Post Office Box 655303, Dallas, Texas 75265
Copyright © 2019, Texas Instruments Incorporated

Looking for pricing, stock, or lifecycle information?

Click below to explore more details on WIN SOURCE:

 [View SN75176BPSRG4 on WIN SOURCE](#)

 [Texas Instruments](#) Information

Optimize Your Supply Chain with WIN SOURCE Solutions

-  Global Sourcing Solution
-  Obsolete Management
-  Cost Control Management
-  Shortage Management
-  Alternative Solution
-  Excess Inventory Management