



**THE DATASHEET OF  
TLE8262-2E**



# INFINEON TECHNOLOGIES SALES OFFICES WORLDWIDE\*

(COUNTRY/AREA)

**Australia**  
Infineon Technologies Australia Pty. Ltd.  
885 Mountain Highway  
**Bayswater, Victoria 3153**  
☎ (+61) 3-97 21 88 88  
Fax (+61) 3-97 21 88 08

**Austria**  
Infineon Technologies Austria AG  
Production / Development Center  
Siemensstraße 2  
**9500 Villach**  
☎ (+43) 5-17 77 0  
Fax (+43) 5-17 77 35 01

Infineon Technologies Austria AG  
Opengasse 200B /31  
**1040 Wien**  
☎ (+43) 1-51 77 71 11 00  
Fax (+43) 1-51 77 71 15 00

**Belgium / Luxembourg Netherlands**  
Infineon Technologies Holding B.V.  
Generaal  
Lemanstraat 67  
**2018 Antwerpen**  
☎ (+31) 10-21 76 80 0  
Fax (+31) 10-21 76 81 9

Infineon Technologies Holding B.V.  
Westblaak 32  
**3012 KM Rotterdam**  
☎ (+31) 10-21 76 80 0  
Fax (+31) 10-21 76 81 9

**Brazil**  
Infineon Technologies  
South America Ltda.  
Avenida Paulista,  
n° 1337-CJ 172  
**01311-200 Cerqueira Cesar São Paulo**  
☎ (+55) 11-33 72 92 40  
Fax (+55) 11-33 72 92 30

**Canada**  
Infineon Technologies  
North America Corp.  
340 March Road, Suite 301  
**Kanata, Ontario K2K 2E2**  
☎ (+1) 866-95 19 51 95 1  
Fax (+1) 613-59 18 95 4

**China**  
Infineon Technologies  
Center of Competence (Shanghai) Co., Ltd.  
12th Floor, Quantum Plaza  
No.27 Zhi Chun Road  
Haidian District  
**Beijing 100083**  
☎ (+86) 10-82 35 61 18  
Fax (+86) 10-82 35 54 74

Infineon Technologies  
Hong Kong Ltd.  
Suite 302, Level 3 Festival Walk  
80 Tat Chee Avenue  
Kowloon Tong,  
**Hong Kong**  
☎ (+852) 28-22 05 00  
Fax (+852) 28-27 97 62

Infineon Technologies  
International Trade (Shanghai) Co., Ltd.  
No. 7 & 8, Lane 647, Song Tao Road  
Zhang Jian Hi-Tech Park  
**Shanghai 201203**  
☎ (+86) 21-61 01 90 00  
Fax (+86) 21-50 80 62 04

Infineon Technologies  
China Co., Ltd.  
Shenzhen Office, Room 1502, Block A  
Tian An International Building  
Renmin Nan Road  
**Shenzhen 518 001**  
☎ (+86) 755-22 19 24 00  
Fax (+86) 755-82 28 02 17

Infineon Technologies  
Taiwan Co., Ltd.  
12F-1, No. 3-2 Yuan Qu Street,  
Nan Kang District  
**Taipei 115**  
☎ (+886) 2-26 55 75 00  
Fax (+886) 2-26 55 75 01 8

**Denmark**  
Infineon Technologies Nordic AB  
Herlev Hovedgade 201A  
**2730 Herlev**  
☎ (+45) 44-50 77 00  
Fax (+45) 44-50 77 01

**Finland**  
Infineon Technologies Nordic AB  
Visitor's Address Upseerinkatu 1  
P.O. Box 276  
**02601 Espoo**  
☎ (+358) 10-6 80 84 00  
Fax (+358) 10-6 80 84 01

**France**  
Infineon Technologies France S.A.S.  
Centre de vie Agora – Bat. A2  
Z.I. des Paluds  
**13400 Aubagne**  
☎ (+33) 44-28 24 61 0  
Fax (+33) 44-28 24 61 8

Infineon Technologies France S.A.S.  
Burolines 2  
2 ter, rue Marcel Doret  
**31700 Blagnac**  
☎ (+33) 5-34 55 13 30  
Fax (+33) 5-34 55 13 34

Infineon Technologies France S.A.S.  
39-47, Boulevard Ormano  
**93527 Saint-Denis CEDEX 2**  
☎ (+33) 1-48 09 72 00  
Fax (+33) 1-48 09 72 90

**Germany**  
Comneon GmbH  
Südwestpark 2-4  
**90449 Nuremberg**  
☎ (+49) 911-37 88 0  
Fax (+49) 911-37 88 10 00

Hfex Development Tools GmbH  
Greschbachstraße 12  
**76229 Karlsruhe**  
☎ (+49) 72-19 62 80  
Fax (+49) 72-19 62 81 89

Infineon Technologies AG  
Siemensstraße 31-33  
**71254 Ditzingen / Stuttgart**  
☎ (+49) 7156-17 91 90  
Fax (+49) 7156- 17 91 99 0

Infineon Technologies AG  
Düsseldorfer Landstraße 401,  
**47259 Duisburg**  
☎ (+49) 203-72 98 71 1  
Fax (+49) 203-72 98 76 0

Infineon Technologies AG  
Naegelbacherstraße 26  
**91052 Erlangen**  
☎ (+49) 9131-97 00 10  
Fax (+49) 9131-97 00 19 9

Infineon Technologies A  
Lindenplatz 2  
**20099 Hamburg**  
☎ (+49) 40-23 51 94 74  
Fax (+49) 40-23 51 94 75

Infineon Technologies AG  
Paderborner Straße 1  
**30539 Hannover**  
☎ (+49) 511-87 65 62 0  
Fax (+49) 511-87 65 62 90

Infineon Technologies AG  
Am Campeon 1-12  
**85579 Neubiberg**  
☎ (+49) 89-23 40  
Fax (+49) 89-23 42 46 94

Infineon Technologies AG  
Südwestpark 65  
**90449 Nuremberg**  
☎ (+49) 911-25 29 30  
Fax (+49) 911-25 29 39 3

Infineon Technologies AG  
Max-Planck-Straße 5  
**59581 Warstein**  
☎ (+49) 2902-76 40  
Fax (+49) 2902-76 41 25 6

**Hungary**  
Infineon Technologies Cegléd Kft.  
Gizella u. 51-57  
**1143 Budapest**  
☎ (+36) 1-47 12 82 4  
Fax (+36) 1-47 12 82 5

**India**  
Infineon Technologies  
India Pvt. Ltd.  
10th Floor, Discoverer Building  
International Technology Park  
Whitefield Road  
**Bangalore 560 066**  
☎ (+91) 80-41 39 20 01  
Fax (+91) 80-41 39 23 33

**Iran**  
Siemens SSK  
No. 32 Taleghani Ave.  
**15875-4773 Teheran**  
☎ (+98) 2-16 14 23 17  
Fax (+98) 2-16 46 30 60

**Ireland**  
Infineon Technologies Ireland Ltd.  
69 Fitzwilliam Lane  
**Dublin 2**  
☎ (+353) 1-79 99 50 0  
Fax (+353) 1-79 99 50 1

**Israel**  
Nisko Ltd.  
2 A, Habarzel Street  
**Tel Aviv 69710**  
☎ (+972) 3-76 57 30 0  
Fax (+972) 3-76 57 33 3

**Italy**  
Infineon Technologies Italia S.r.l.  
Via Vipliteno, 4  
**20128 Milan**  
☎ (+39) 2-25 20 41  
Fax (+39) 2-25 20 44 39 5

Infineon Technologies Japan K.K.  
Gate City Osaki, East Tower  
21F /22F /23F  
**211-2 Osaki  
Shinagawa-ku  
Tokyo 141-0032**  
☎ (+81) 3-57 45 71 00  
Fax (+81) 3-57 45 74 10

**Japan**  
Infineon Technologies Japan K.K.  
Gate City Osaki, East Tower  
21F /22F /23F  
**211-2 Osaki  
Shinagawa-ku  
Tokyo 141-0032**  
☎ (+81) 3-57 45 71 00  
Fax (+81) 3-57 45 74 10

Infineon Technologies Japan K.K.  
Maruyama Nissel Building 14F  
2-14-21 Nishiki, Naka-ku  
**Nagoya-shi, Aichi 460-0003**  
☎ (+81) 52-22 31 57 0  
Fax (+81) 52-22 31 46 1

Infineon Technologies Japan K.K.  
ORIX-Dojima Building 8F  
2-1-31, Dojima, Kita-ku  
Osaka-shi,  
**Osaka 530-0003**  
☎ (+81) 6-47 97 44 60  
Fax (+81) 6-47 97 44 62

**Korea**  
Infineon Technologies Korea Co., Ltd.  
4th Floor Sigma Tower  
7-19 Shincheon-dong Songpa-gu  
**Seoul 138-734**  
☎ (+82) 2-34 60 09 50  
Fax (+82) 2-34 60 09 01

Infineon Technologies Korea Co., Ltd.  
15th Floor SI Technoville 60-19  
Gasandong Geumcheongu  
**Seoul 153-801**  
☎ (+82) 2-34 60 08 80  
Fax (+82) 2-34 60 09 09

**Mexico**  
Everest Sales & Solutions  
Av. Manuel Acuña 2674-101  
Col. Ladrón de Guevara  
**44680 Guadalajara, J. AL**  
☎ (+52) 33-36 42 21 01  
Fax (+52) 33-36 40 65 62

**Poland**  
Siemens Sp. z o.o.  
Ul. Zupnicza 11  
**03-821 Warsaw**  
☎ (+48) 22-87 09 15 0  
Fax (+48) 22-87 09 15 9

**Puerto Rico**  
Klamco Electronics  
527 Street QH No. 1  
Country Club  
**Carolina, PR 00982**  
☎ (+1787) 257-79 22  
Fax (+1787) 257-79 61

**Russia**  
Infineon Technologies RUSS LLC  
Leninsky prospect 113 / 1  
**117 198 Moscow**  
☎ (+7) 495-95 65 19 5  
Fax (+7) 495-95 65 19 5

**Singapore**  
Infineon Technologies Asia  
Pacific Pte. Ltd.  
8 Kallang Sector  
**Singapore 349 282**  
☎ (+65) 68-76 28 88  
Fax (+65) 68-76 31 22

**South Africa**  
Siemens Components  
P.O. Box 3438  
Halfway House 1680  
**2146 Sandton**  
☎ (+27) 11-70 66 09 9  
Fax (+27) 11-70 69 04 9

**Spain**  
Infineon Distribution Sales Office IBERIA  
c/ Chile, 10 12 Planta – Oficina 141  
Edificio Madrid 92  
**28290 Las Rozas de Madrid, Madrid**  
☎ (+34) 91-63 05 72 8  
Fax (+34) 91-63 05 72 8

Siemens, S.A.  
División de Componentes  
Ronda de Europa, 5  
**28760 Tres Cantos-Madrid**  
☎ (+34) 91-51 47 15 5  
Fax (+34) 91-51 47 01 4

**Sweden**  
Infineon Technologies Sweden AB  
Isafjordsgatan 16  
**164 81 Kista**  
☎ (+46) 8-75 75 00 0  
Fax (+46) 8-75 74 61 2

**Switzerland**  
Infineon Technologies  
Schweiz AG  
Badener Strasse 623  
P.O. Box 1570  
**8048 Zürich**  
☎ (+41) 1-49 78 04 0  
Fax (+41) 1-49 78 05 0

**Turkey**  
Infineon Technologies Turkey  
Sahit Mehmet Fatih Ongul Sok.  
Bagdatlioglu Plaza No:3  
Office-4, Kozyatagi  
**34742 Kozyatagi, Istanbul**  
☎ (+90) 216-46 40 75 5  
Fax (+90) 216-46 40 75 6

**United Kingdom**  
Infineon House  
Great Western Court  
Hunts Ground Road  
Stoke Gifford  
**BRISTOL BS34 8HP**  
☎ (+44) 11-79 52 88 23

Infineon Technologies  
Kingswood  
Kings Ride  
**Ascot SL5 8AD**  
☎ (+44) 1344 865900

**U.S.A.**  
Infineon Technologies  
North America Corp.  
2529 Commerce Drive, Suite H  
**Kokomo, IN 46902**  
☎ (+1) 765-45 61 92 8  
Fax (+1) 765-45 63 83 6

Infineon Technologies  
Industrial Power, Inc.  
1050 Route 22  
**Lebanon, NJ 08833**  
☎ (+1) 908-23 65 62 1  
Fax (+1) 908-23 65 62 0

Infineon Technologies  
North America Corp.  
19111 Victor Parkway  
**Livonia, MI 48152**  
☎ (+1) 734-77 95 00 0  
Fax (+1) 734-77 95 00 1

Infineon Technologies  
North America Corp.  
12770 High Bluff Drive, Suite 100  
**San Diego, CA 92130**  
☎ (+1) 858-50 92 16 0  
Fax (+1) 858-50 92 16 1

Infineon Technologies  
North America Corp.  
640 N. McCarthy Blvd.  
**Milpitas, CA 95035**  
☎ (+1) 866-95 19 51 9

## The Robust Path to Automotive Networks

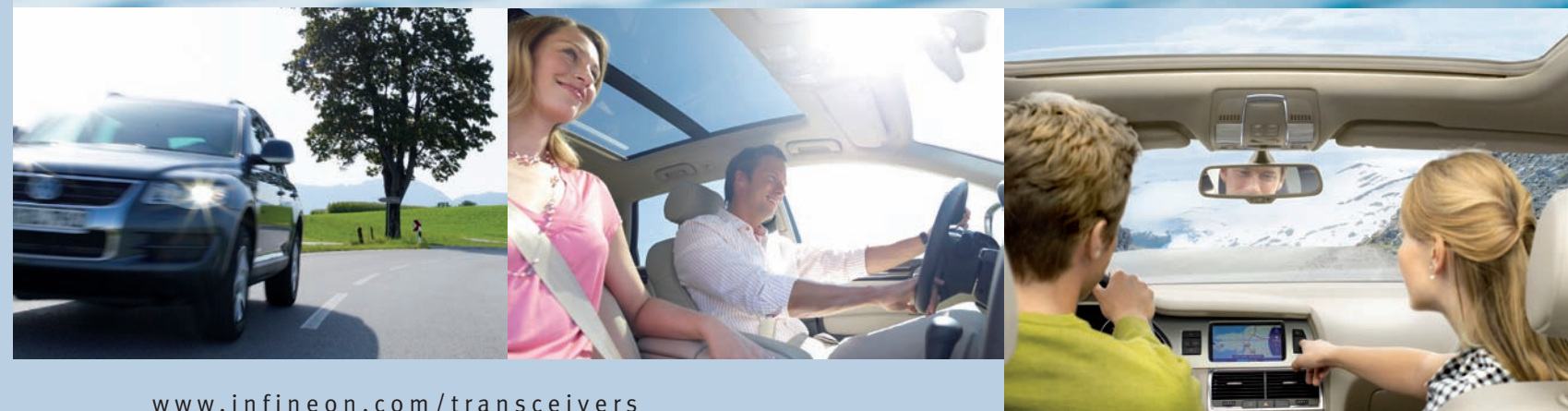
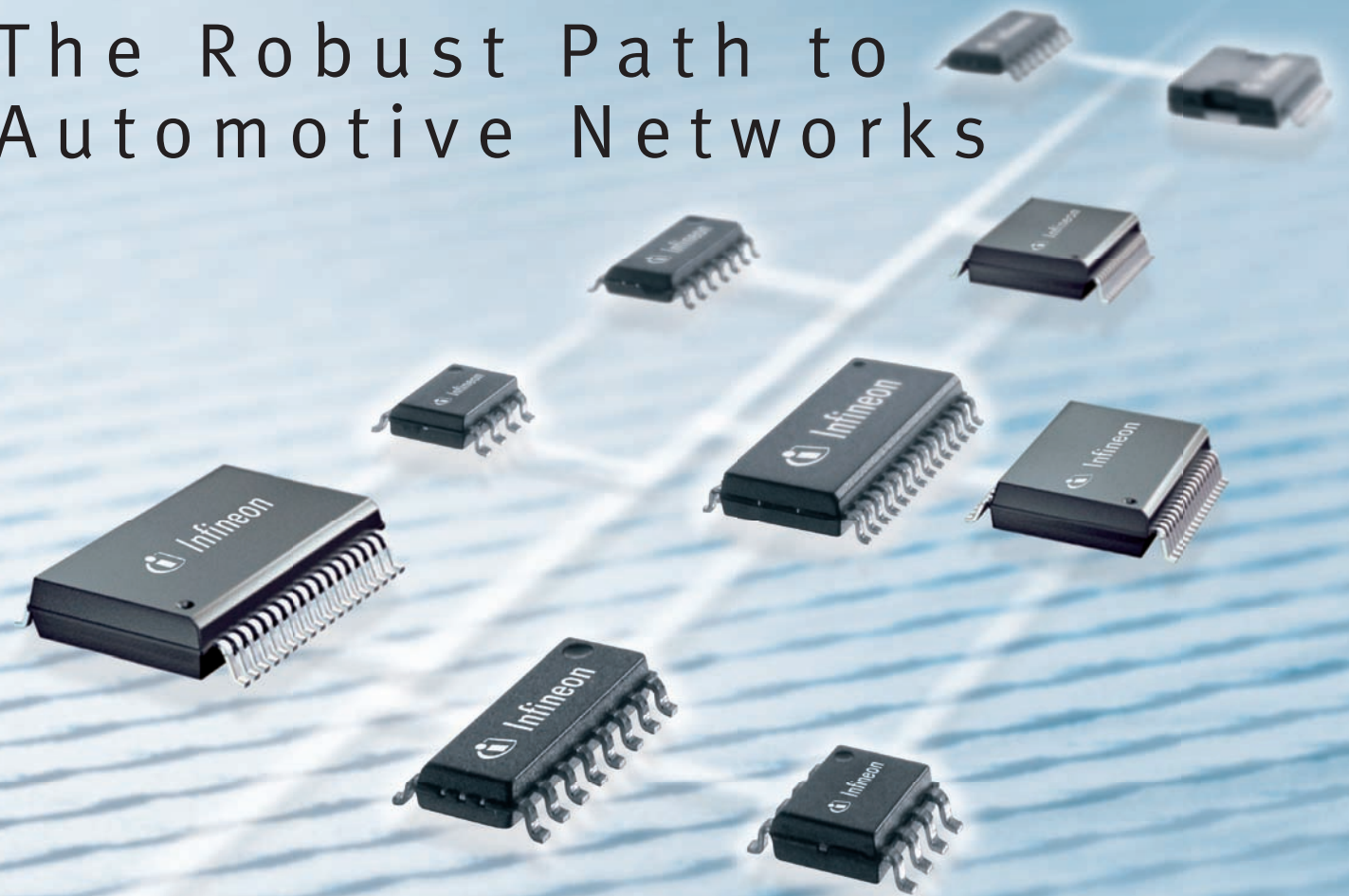

www.infineon.com/transceivers

\* and representative offices

**Edition 2008**  
Published by  
**Infineon Technologies AG**  
81726 Munich, Germany  
© 2008 Infineon Technologies AG  
All rights reserved.

Order no. B152-H8619-G1-X-7600



Never stop thinking

# Your Partner of Choice for Automotive Communication Interfaces

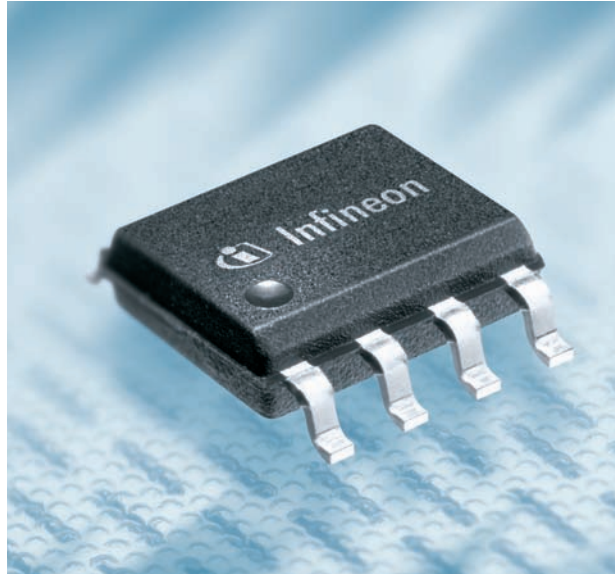
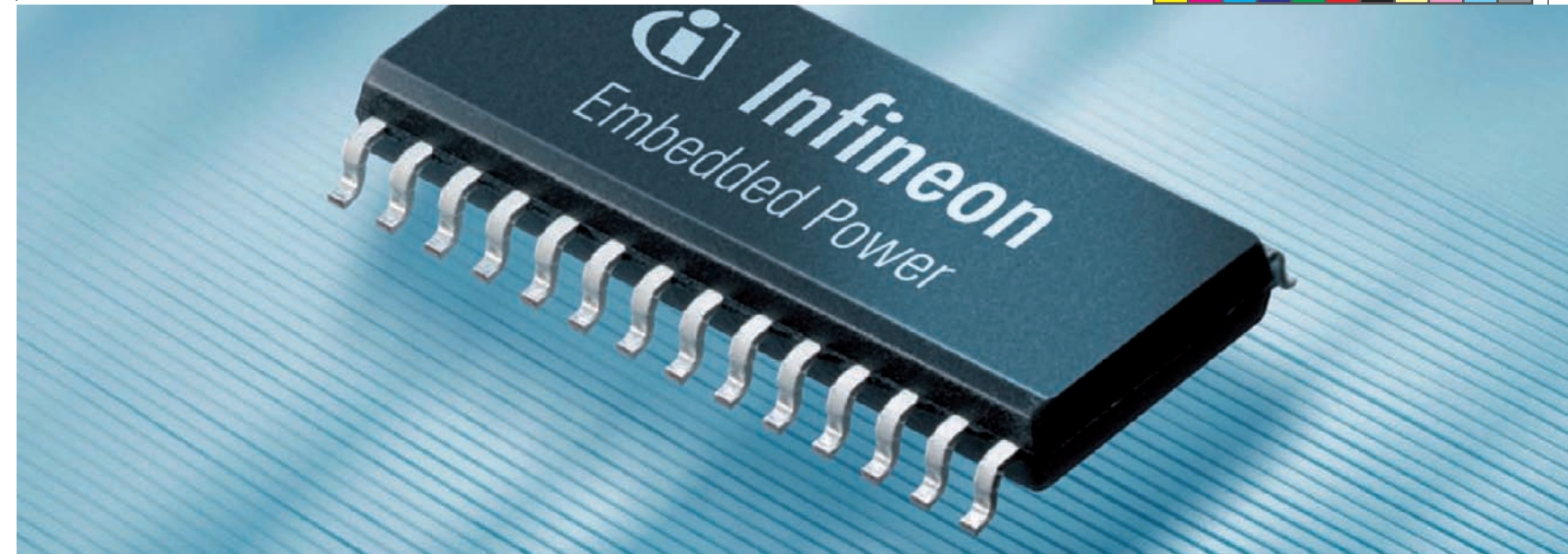

WORLD LEADER IN AUTOMOTIVE electronics for 35 years, Infineon focuses on the in-vehicle networking, a major driver today for innovation in the automotive field, meeting the ever-increasing demands of consumers for comfort, performance and safety.

WITH OVER TEN YEARS' EXPERIENCE developing communication interfaces, Infineon offers an extensive product line of transceivers, system basis chips and Embedded Power solutions for CAN and LIN protocols, from the mature to the advanced.

CONTINUOUSLY IMPROVING ITS SPT chip technology, Infineon provides solutions for the challenges faced by the automotive industry, featuring the best ESD and EMC combined performances.

IN THIS BROCHURE Infineon introduces its transceivers and system basis chips portfolio, with a detailed description of their distinctive key functions and benefits.

THE PRODUCT BRIEFS INCLUDED provide a comprehensive overview of current products, as well as the latest product proposals.

FOR MORE DETAILED INFORMATION visit the Infineon website at [www.infineon.com/transceivers](http://www.infineon.com/transceivers) or contact your sales partner listed on the back of this brochure.

## Embedded Power – Relay Driver ICs – TLE78xx: Application Example

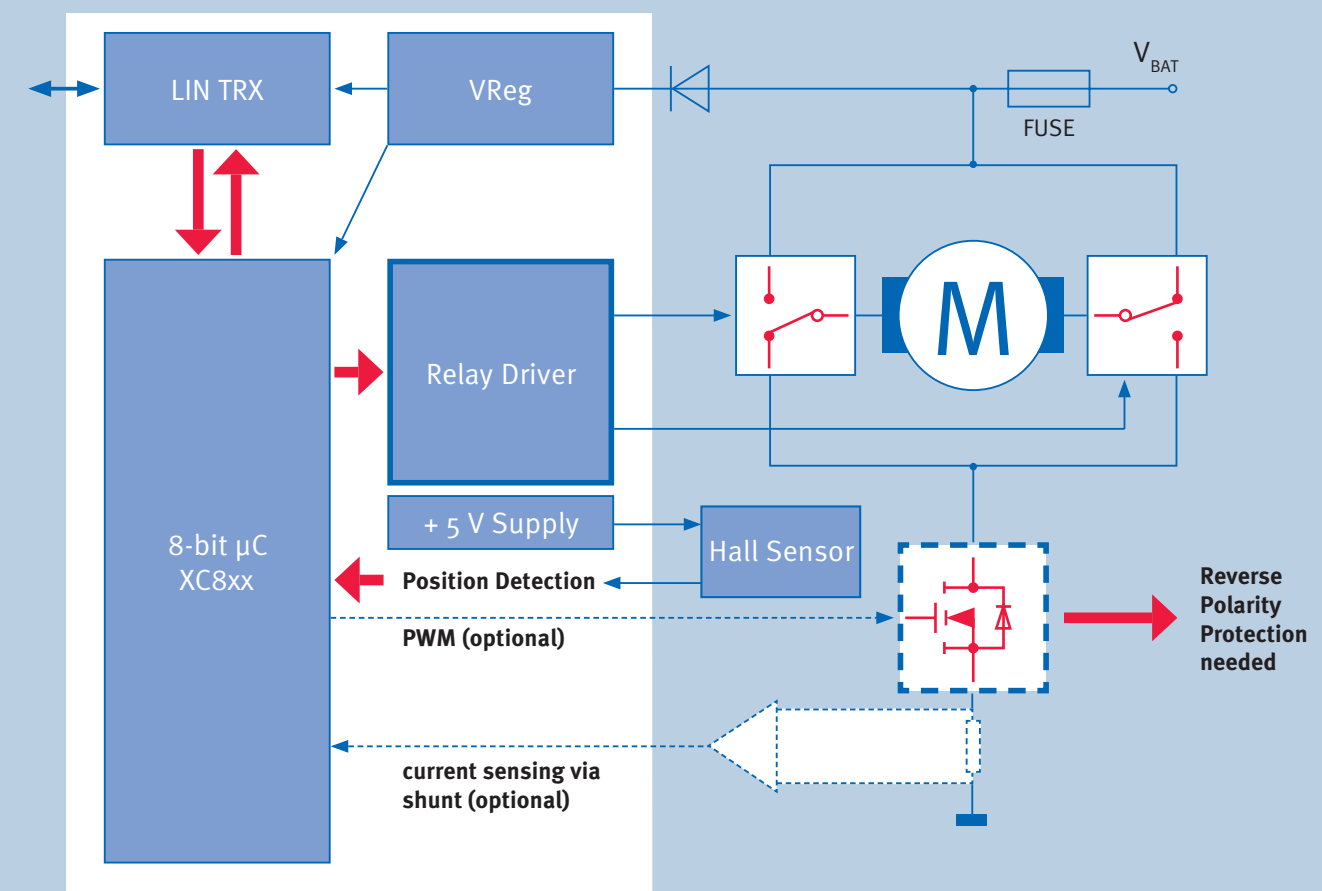

### Tool Support for ePower Relay Driver

- Evaluation Board TLE78xx
  - Power & LIN Interface
  - JTAG Connector (debugging / programming)
  - Switch Inputs, Relay, LEDs available
- 8-Bit  $\mu$ C XC8xx:
  - KEIL  $\mu$ Vision C-Compiler, Assembler, Debugger and Programmer for Flash Memory
  - GNU "Open Source" Tools available
  - KEIL Real Time Operating System RTX51

### Application

- Window Lift Module
- Seat module
- Sun-roof module



## Infineon Transceivers and System Basis Chips

- The experience of a leading edge automotive electronics supplier
- Comprehensive product portfolio of stand-alone transceivers and standard on-chip solutions
- Outstanding ESD and EMC combined performances

Protocol	High Speed CAN	Low Speed CAN	LIN	High Speed CAN + LIN
Stand-alone transceivers	TLE6250G / GV33 TLE6251DS TLE6251G	TLE 6254-3G	TLE6258-2G TLE7259-2G TLE7269G	
System Basis Chips		TLE6263-3G TLE6266G	TLE6285G TLE6286G TLE8458G	TLE7263E TLE826xE
Embedded Power			TLE7810	

## Abbreviations

- SPT Smart Power Technology
- SBC System Basis Chip
- EMC Electro Magnetic Compatibility
- CAN Controller Area Network
- ESD Electro Static Discharge
- OEM Original Equipment Manufacturer
- LIN Local Interconnect Network
- ePower: Embedded Power

# The Benefits of an Automotive Dedicated Technology

## Living Automotive Excellence

BECAUSE TRANSCEIVERS play a vital role in today's more and more complex interconnected cars, developing innovative solutions is not enough. With the "Automotive Excellence" program Infineon can ensure the highest safety possible, implementing a zero-defect mind-set for processes, product development, production and logistics: no compromise when it comes to quality! First results can be recognized already.

Average failure (ppm) for TLE6250G

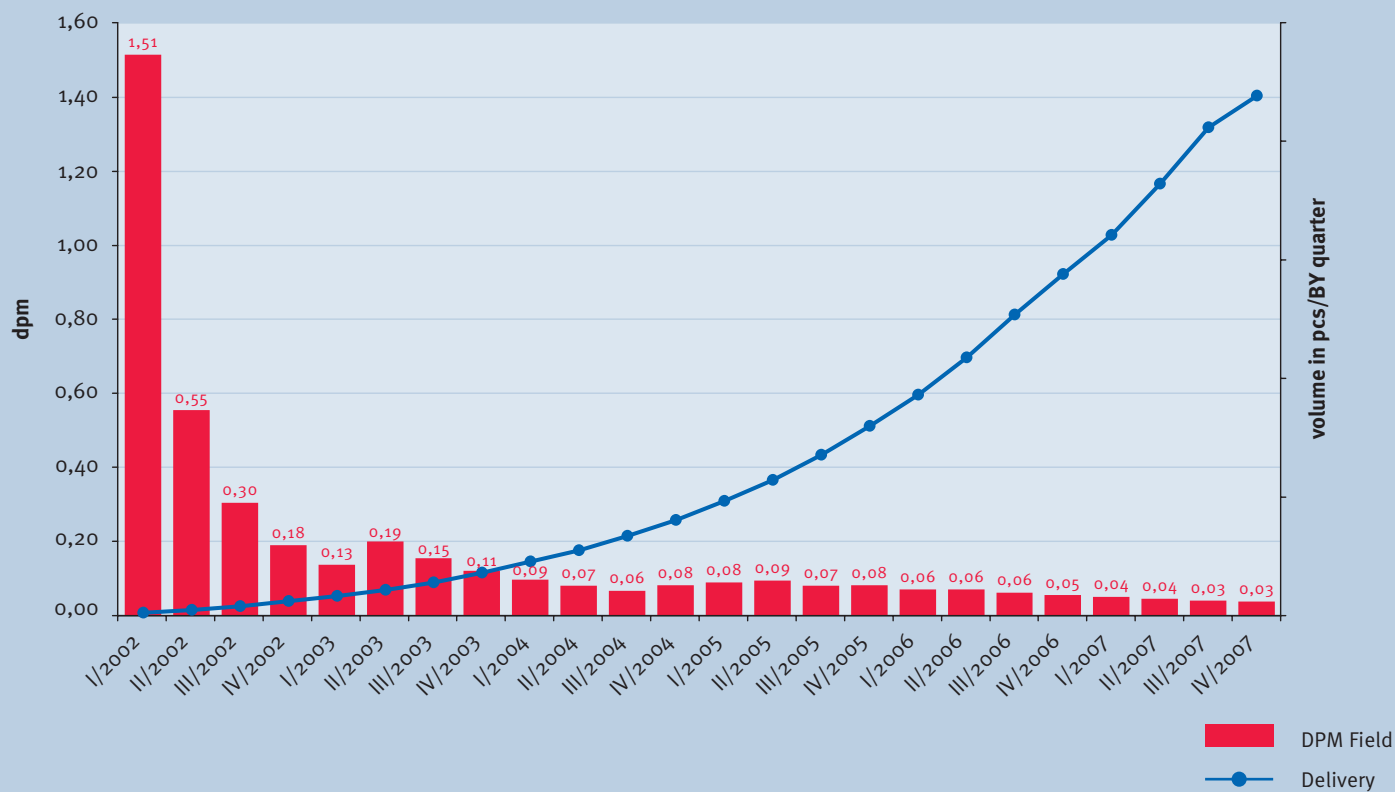

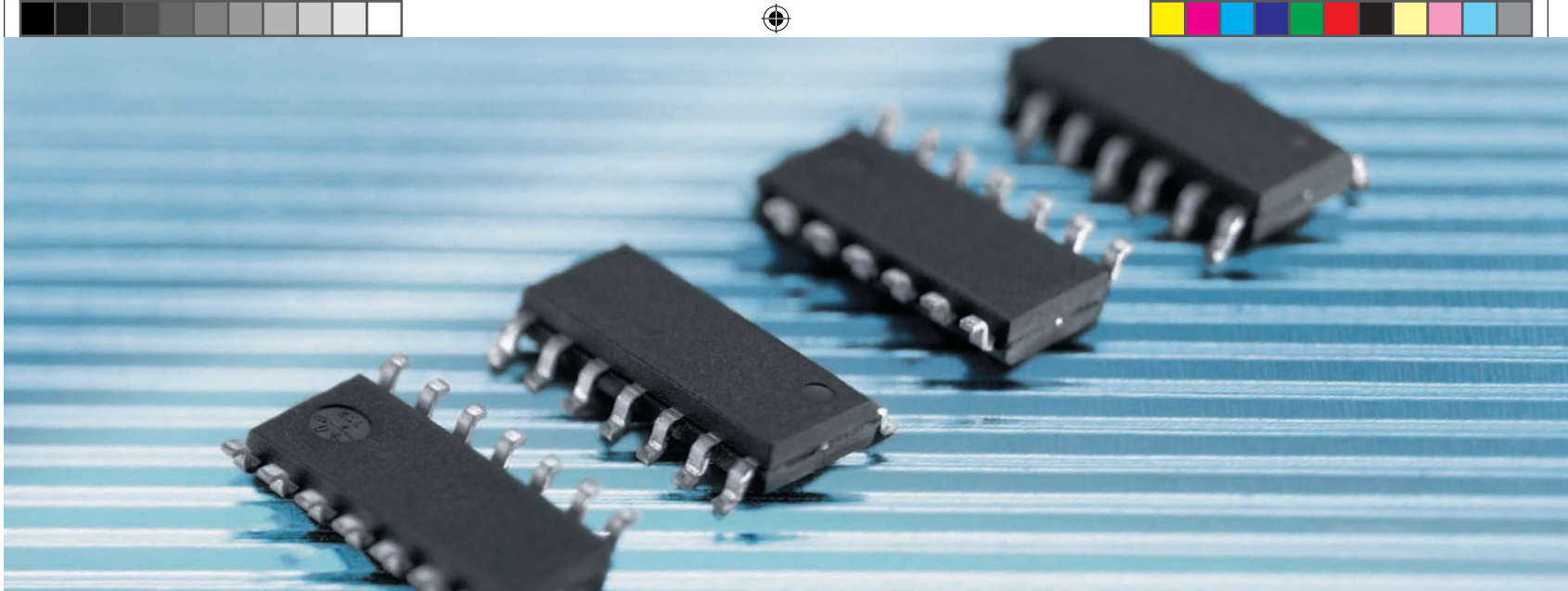

## Robust Package: for a safer lead-free processing

AN ELEMENT OF THE AUTOMOTIVE EXCELLENCE PROGRAM, the robust package, significantly improves the reliability of both, the component and the application. This new package concept enables Infineon to address the lead-free requirements with improved quality, going beyond the today's AEC Q101 specifications.

### Green and Robust package

**Solder Die Attach (PbSnAg)**

- ▶ allowing increased solder reflow (260 °C) due to green requirement

**Low Stress / Molding Compound MC**

- ▶ halogen free
- ▶ reducing thermomechanical stress in package

**Robust Passivation**

- ▶ reducing passivation cracks and shifted metallisation

**Plating**

- ▶ lead free

**Adhesion promoter**

- ▶ providing good adhesion to all interfaces

### Robust package

**Stress test: Temperature Cycling** (–55 °C, +150 °C)  
Preconditioning:  
3 times solder reflow profile, 260 °C peak temp.

**Stress test: Autoclave** (Temp. 121 °C, 100 % humidity)  
Preconditioning:  
3 times solder reflow profile, 260 °C peak temp.

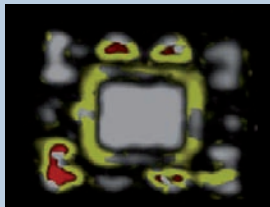

Competition



Infineon Green & Robust,  
SPT Technology

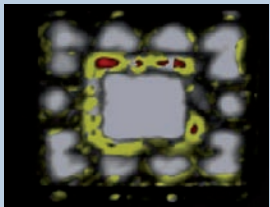

Competition

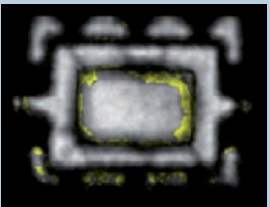

Infineon Green & Robust,  
SPT Technology

Scanning acoustic microscope, Ultrasonic images of the front, delamination in red (major) / yellow (minor)



## ESD Robustness: holding the leadership in performance and innovation

ONE OF THE SPECIFIC CHALLENGES for a transceiver device is to withstand the harsh signals that occur on the bus, from ESD (Electro Static Discharges) to voltage peaks resulting from the parasitic inductances of bus cables. A robust transceiver also does not need expensive external protection components such a zener diodes or varistors.

OVER THE PAST YEARS Infineon developed and improved an innovative integrated protection that enables the dissipation of the energy, which is converted during an ESD event, through the chip from top to bottom. Silicon On Isolator (SOI) type technologies where the active side of the chip is decoupled from its bottom by an insulator do not allow such concepts. Infineons products can hold more than 10 kVolts of discharges using ISO 61000-4-2 test standard, an application oriented testing method that applies an energy which is five times higher than the standard HBM (Human Body Model) test that simulates typical handling events.

### ESD Robustness of TLE7259-2G in comparison with the competition

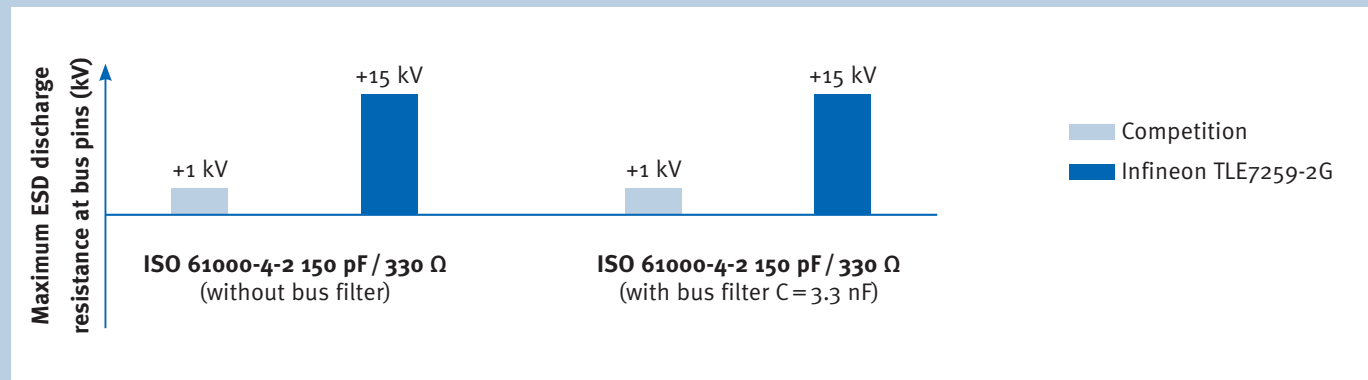

### ESD Robustness of TLE6251DS in comparison with the competition

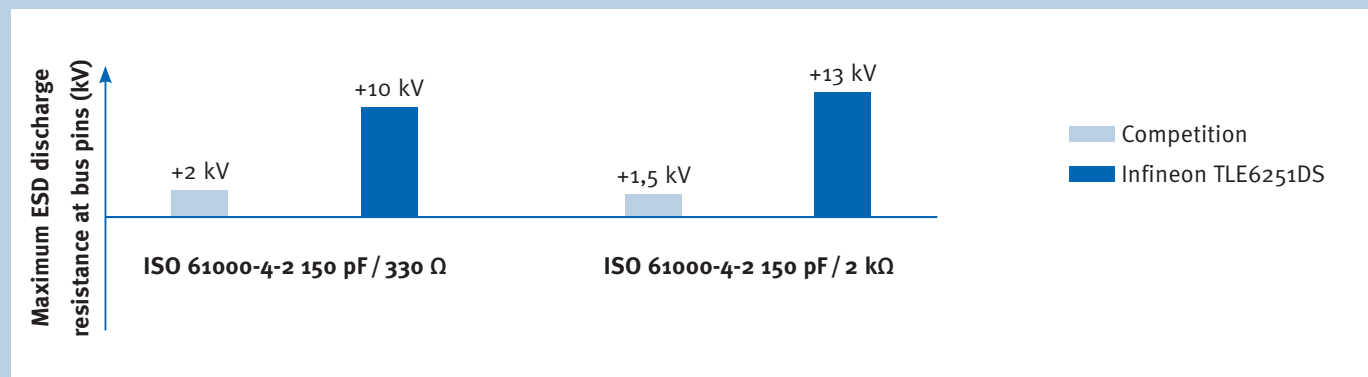

# Stand-alone Transceivers

## High Speed CAN Transceivers

### Excellent robustness dedicated to a broad range of applications

AT FIRST USED for powertrain networks, the High Speed Controller Area Network (CAN) is now the most used automotive protocol within the car, with bus speeds from 125 kBauds to 1 Mbauds, offering an excellent cost to performance ratio.

Building on the success of the TLE6250, Infineon addresses the additional needs of today's High Speed CAN automotive networks used for body and comfort applications. Thanks to its unique expertise, Infineon could even greatly improve the ESD robustness of its new products.

### TLE6250G and TLE6250GV33 – becoming market standards

ADOPTED BY MOST of the OEMs around the world, this device (TLE6250G for 5 V logic, TLE6250GV33 for 3.3 V logic) is a new market standard due to its important benefits:

- Excellent EMC performance
- Outstanding ESD robustness (6 kV Human Body Model)
- Receive-only mode

### TLE6251DS – ideal for partially powered network concepts

THE TLE6251DS in a standard DSO-8 package can be compared to the TLE6250 with an additional Bus wake-up capability. Bus reverse current is zero when the device is unpowered, so that it does not affect the rest of the network as an “invisible” node. This makes the TLE6251DS suitable for key-on nodes applications in partially powered networks.

### TLE6251G – for permanently connected nodes

THE TLE6251G in a DSO-14 package controls in addition the supply for the entire node. Permanently powered by the battery, it features a sleep mode with very low quiescent current and an inhibit output to power up a voltage regulator, when getting either a remote wake-up from the bus or a local wake-up on the wake-up pin. Functions include a set of fail-safe flags, and a network failure diagnosis.

Infineon presents herewith a solution for the most advanced High Speed CAN automotive concepts.

### Overall functional description, TLE6250G

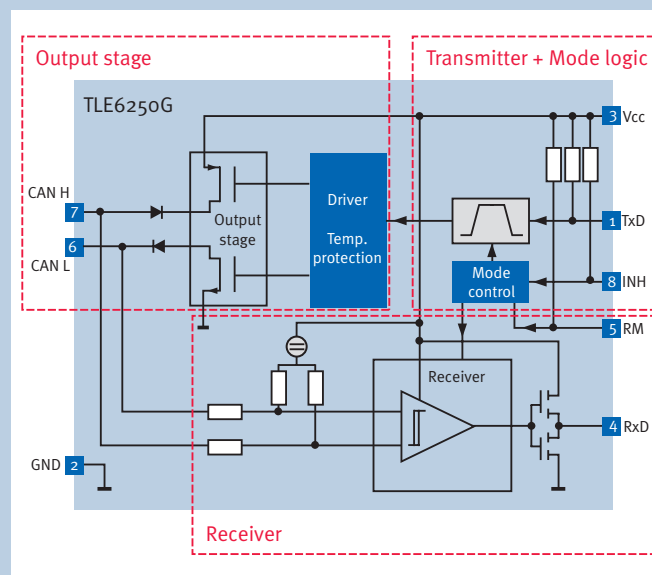

# Stand-alone Transceivers

## Low Speed CAN Transceivers

### Setting up a new reference

THE 125 KBAUD Fault Tolerant CAN physical layer became a standard in Europe for body and convenience networks because of its ability to switch from a differential communication mode to a single-wire mode in the event of an open or shorted bus wire. Infineon continuously improved the performances and the functionalities of its Fault Tolerant transceivers resulting in the advanced TLE6254-3G, establishing a new reference on the Low Speed CAN transceiver market.

### TLE6254-3G – approved by most major car manufacturers

THE TLE6254-3G benefits from a zero-fail certification of the ICT (International Conformance Testing) and enhanced features such as:

- Low quiescent current in sleep mode and standby mode
- Receive-only mode preventing erratic messages
- 6 kV (Human Body Model) ESD robustness

### Application example TLE6254-3G

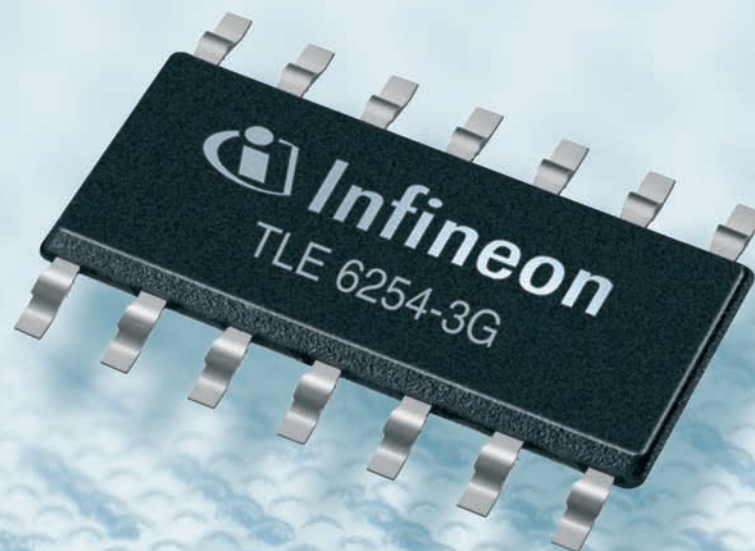
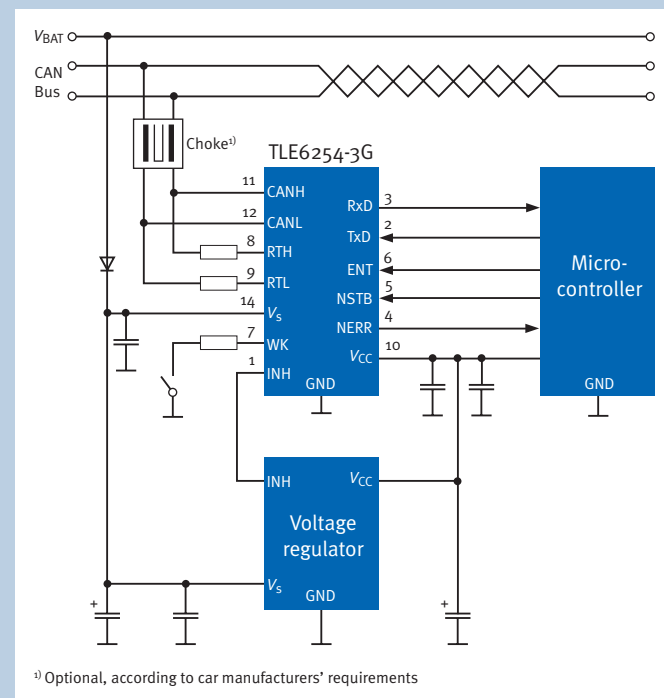

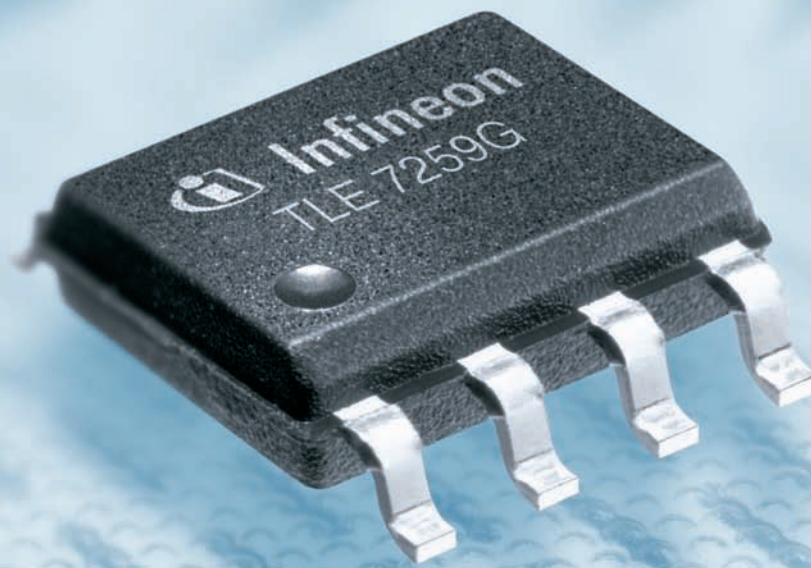

## LIN Transceivers

### Top performances for low-cost networking

LOCAL INTERCONNECT NETWORK (LIN) bus by allowing a basic local network connection between the CAN backbone and actuators, sensors or switches has tremendously reduced the design efforts and costs. It is thus used in a fast-growing range of body and convenience applications. As an active member of the LIN consortium Physical Layer and Conformance Tests working groups, Infineon has adapted its portfolio to the latest applications and norms.

### TLE6258-2G – a standard k-Line (ISO9141) and LIN transceiver

THE TLE6258-2G is a cost-optimized solution suiting a broad range of designs:

- Compatible to the LIN norms LIN 1.3, 2.1
- Bus wake-up capability with low power mode (standby)
- Bus short to ground and battery protection

### TLE7259-2G – the enhanced Infineon LIN transceiver

THE TLE7259-2G offers a sleep mode in conjunction with an inhibit output pin to control the voltage regulator, mastering the whole node supply for an optimized overall consumption. The TLE7259-2G is a leading product combining outstanding benefits:

- Excellent EMC coupled to a strong ESD robustness
- Very low quiescent current and bus leakage current in sleep mode
- Compatibility to 3.3 V and 5 V logic
- Specific LIN 1.3, 2.1 version: TLE7259-2GE
- Specific SAE J 2602 version: TLE7259-2GU

### TLE7269G – the first ever Twin-LIN device

THE TLE7269G offers two LIN transceiver cells type TLE7259-2 in a SO14 package, which gives additional benefits:

- Smaller overall board area
- Integrated pull-up resistors to Vcc for logic pins
- Reduced total quiescent current
- Layout single / twinLIN scalability

### Pin out TLE7269G

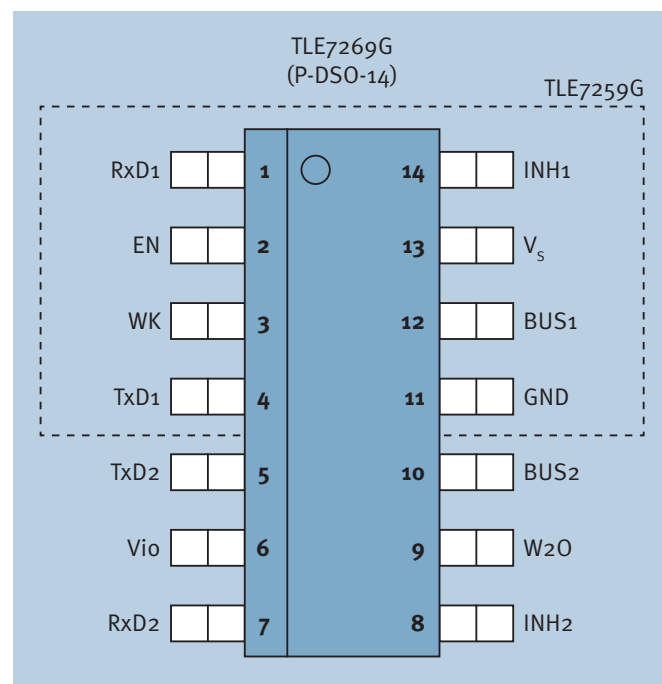

# System Basis Chips

INFINEON HAS DEVELOPED several integrated components to enable the design of cost-effective, robust and high-performance modules, to meet the harsh requirements of the automotive industry for quiescent current, system area and costs.

AS A WELL-ESTABLISHED automotive supplier, Infineon combines its experience with a wide portfolio of transceivers, voltage regulators, high side and low side switches, to design standard integrated solutions meeting the specific demands of its customers.

THE FLEXIBILITY and performance of the SPT technology allows Infineon to use a systematic cell block approach, up-integrating already approved and qualified circuits. This allows a fast and reliable concept phase, and reduces the product time to market.

## Typical car application

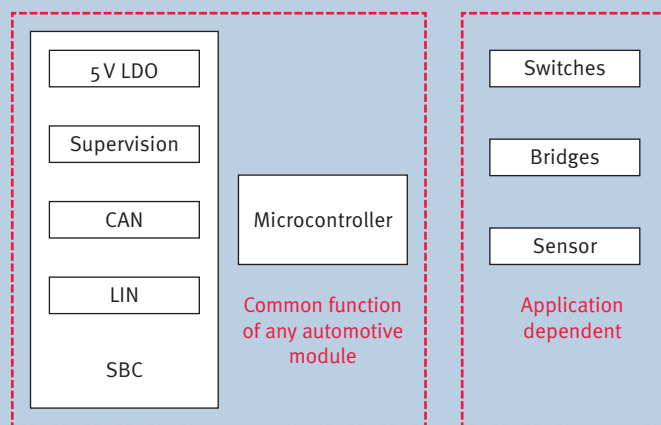

## Customer's Benefit

USING A STANDARD integrated solution, reduces the design-in time significantly. The hardware is herewith simplified, and the software can be adapted to fit to new requirements, enabling an efficient reuse of the running designs.

A VERY LOW quiescent current is achieved, because all the functions requiring a permanent connection to the battery are integrated in one chip. The system cost can be significantly reduced due to the fact that none of the additional external components required in a discrete solution are needed.

INTEGRATED FUNCTIONS including low battery early warning, window watchdog, temperature warning flag and over-temperature protection, meet the increasing need for safety in the applications, with a minimum increase of cost or system area.

THE DEVICES CAN WORK within wide battery voltage and temperature ranges. Fail-safe outputs allow the implementation of a "limp-home" hardware, in case of malfunctions in the vehicle.

THE INFINEON PRODUCT PORTFOLIO offers a wide range of protocols currently used by OEMs, High Speed CAN, Low Speed Fault Tolerant CAN and LIN. All products fit the relevant ISO standard and have ICT certification.



## The Low Speed CAN SBCs

AS A PIONEER of System Basis Chips solutions, Infineon has offered SBCs with Fault Tolerant Low Speed CAN interface since 1998, dedicated to body and convenience modules. The products below benefit from the performances of the latest transceiver cell generation.

### TLE6263-3G – the universal body IC

THE TLE6263-3G meets the main smart power and supply requirements, among the most important features:

- Fault Tolerant Low Speed CAN transceiver
- Voltage regulator (5 V / 150 mA)
- 1 High Side driver (150 mA)
- Local wake-up pin(s)
- Window watchdog

### TLE6266G – the dedicated door module IC

THE TLE6266G reflects the specific needs for door module control, offering:

- Fault Tolerant Low Speed CAN transceiver
- Voltage regulator (5 V / 45 mA)
- 2 Low Side drivers
- 3 High Side drivers
- Local wake-up pin(s)
- Window watchdog

Block diagram TLE6266G

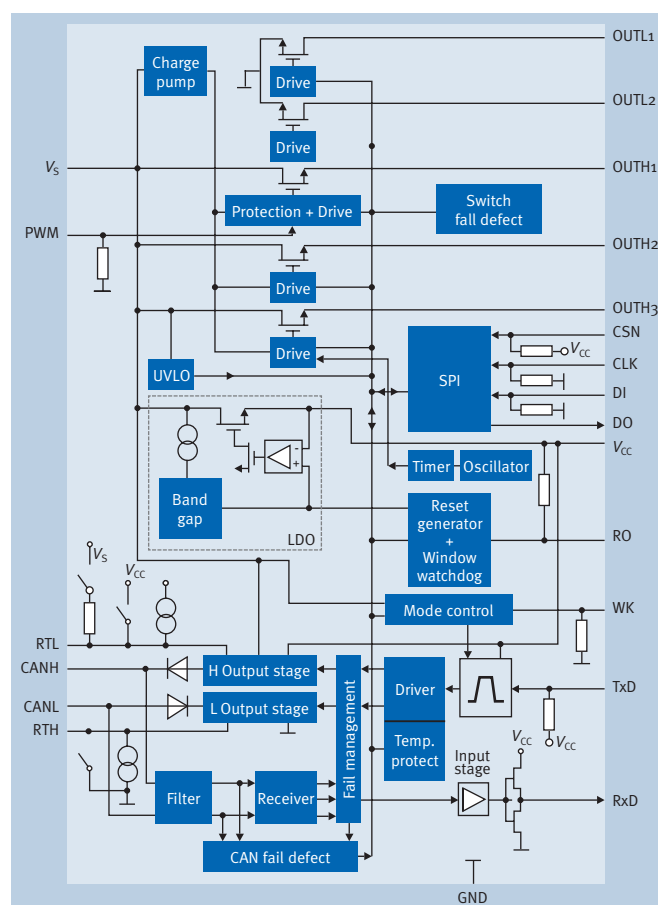

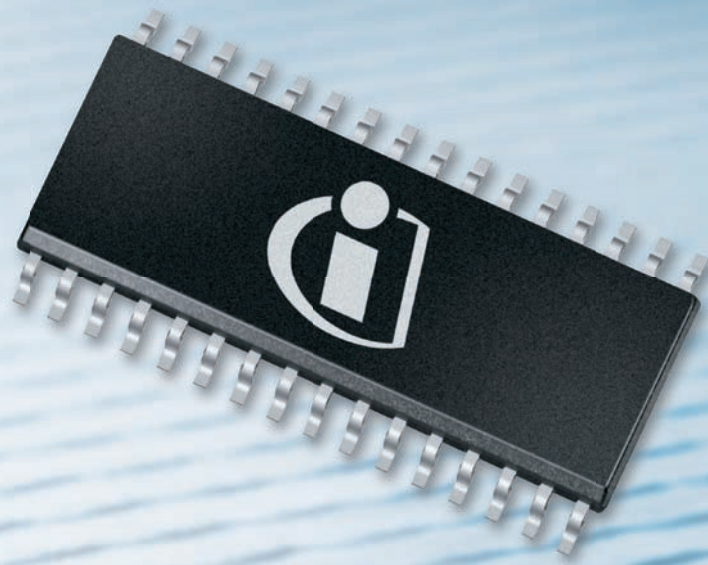

## The LIN SBCs

INFINEON PROVIDED one of the first LIN SBCs on the market and is now extending its portfolio to provide ideal alternative to common discrete component sets of LIN slave control units.

### TLE8458G – for the simplest LIN applications

A COST EFFICIENT solution for LIN slave modes with low power needs:

- LIN transceiver LIN 2.1 and J2602 compliant
- Voltage regulator (5 V / 40 mA)
- Local wake-up pin
- SO8 standard package

### TLE6285G and TLE6286G – smart cost and space optimization

TWO FUNCTIONS in one package covering standard requirements:

- LIN Transceiver, LIN2.1 compliant
- Voltage regulator (5 V / 150 mA)
- Watchdog (TLE6286G)
- Adjustable under-voltage reset (TLE6285G)
- SO16 standard package

### Pin out TLE8458G

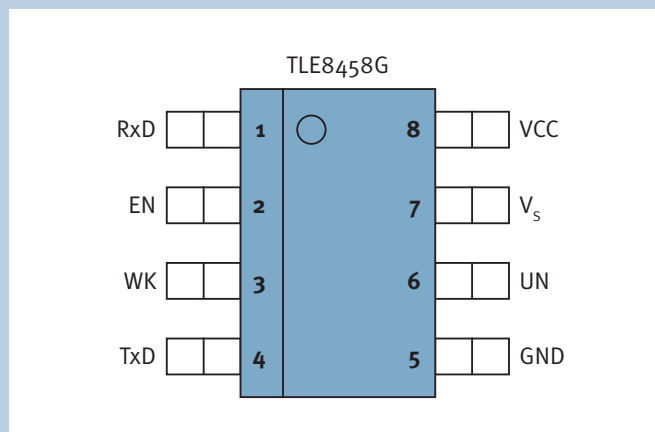



## The High Speed CAN SBCs

AMONG THE LAST product developments, Infineon sets its know-how to meet the growing demand for High Speed CAN body networking, with higher supply capacity as well as optimized low power current consumption and extended safety benefits.

### TLE7263E – serves the most demanding needs for CAN to LIN gateways

THE TLE7263E meet the requirements for CAN to LIN gateways commonly needed on Central Body Modules, climate or door modules, with enhanced safety features and a quiescent current as low as 60  $\mu\text{A}$  :

- High Speed CAN Transceiver (with bus wake-up, bus failure diagnostics), ISO11898-5 compliant
- LIN Transceiver, LIN2.1 and SAEJ2602 compliant
- Dual Voltage Regulator
  - V1 (5 V / 150 mA) for microcontroller
  - V2 (5 V / 150 mA) for internal CAN and external devices
- 1 High Side driver (150 mA)
- 4 Local wake-up pins
- Window watchdog
- Sense Input and fail-safe output

### TLE8261/2/3/4E – for flexible and scalable designs

THIS NEW PRODUCT FAMILY combines a cost optimized concept with a flexible supply capability and a scalable number of LIN cells over the four pin compatible family members:

- High Speed CAN Transceiver (with bus wake-up, bus failure diagnostics), ISO 11898-5 compliant
- Multiple LIN cells from 0 (TLE8261E) to 3 (TLE8264E)
- Dual integrated voltage regulator (each 5 V / 150 mA)
- External power transistor tracking (up to 5 V / 400 mA)
- 1 Local wake-up pin
- Window watchdog
- Configurable Limp Home output

### Block diagram TLE7263

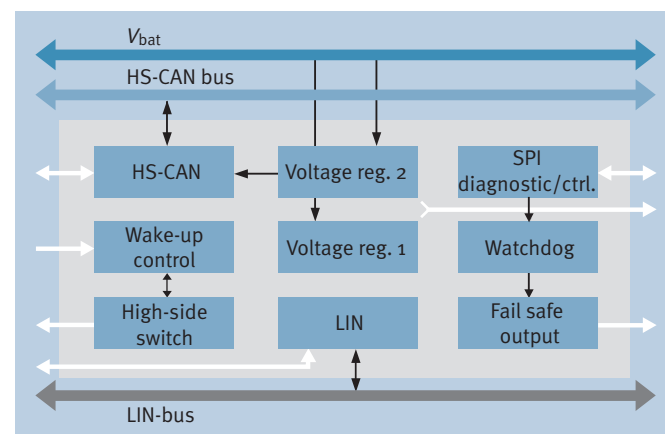

# Embedded Power

EMBEDDED POWER is a System in a Package (SiP) solution. It incorporates an 8-bit microcontroller compatible to the standard 8051 core with On-Chip debug Support (OCDS) and a System-Basis-Chip (SBC). The SBC is equipped with LIN / SAE J2602 compliant LIN Transceiver, low-dropout voltage regulator (LDO) as well as two low-side switches (relay driver) and supply (+5 V), e.g. to supply hall sensors (TLE4966). An additional high-side driver for driving LEDs is also available.

FOR MICROCONTROLLER supervision and additional protection of the circuit a programmable window watchdog circuit with a reset feature, supply voltage supervision and integrated temperature sensor is implemented.

SBC, MICROCONTROLLER AND LIN module offer power modes in order to support terminal 30 connected automotive applications. A wake-up from the low power mode is possible via a LIN bus message or wake-up inputs.

THIS INTEGRATED CIRCUIT is realized as Multi-Chip-Module (MCM) in a P-DSO-28 and in P-DSO-52 package in the future, and is designed to withstand the severe conditions of automotive and industrial applications.

## Customer's benefits:

- Cost efficiency and quality
- Space saving
- Zero defect

## Features:

- 8-bit  $\mu$ Controller
  - 8051 compatible
  - Flash / EEPROM
  - 10-bit A/D Converter
  - 16-bit Timers
  - On-Chip-Debug System
- Voltage Regulator
- LIN Transceiver
- High-Side Switches (Hall & SED Supply)
- 2 x Low-Side Switch
- 5 x wake-up inputs
- Standard SPI Interface

## Embedded Power Product Family – Relay Driver TLE78xx

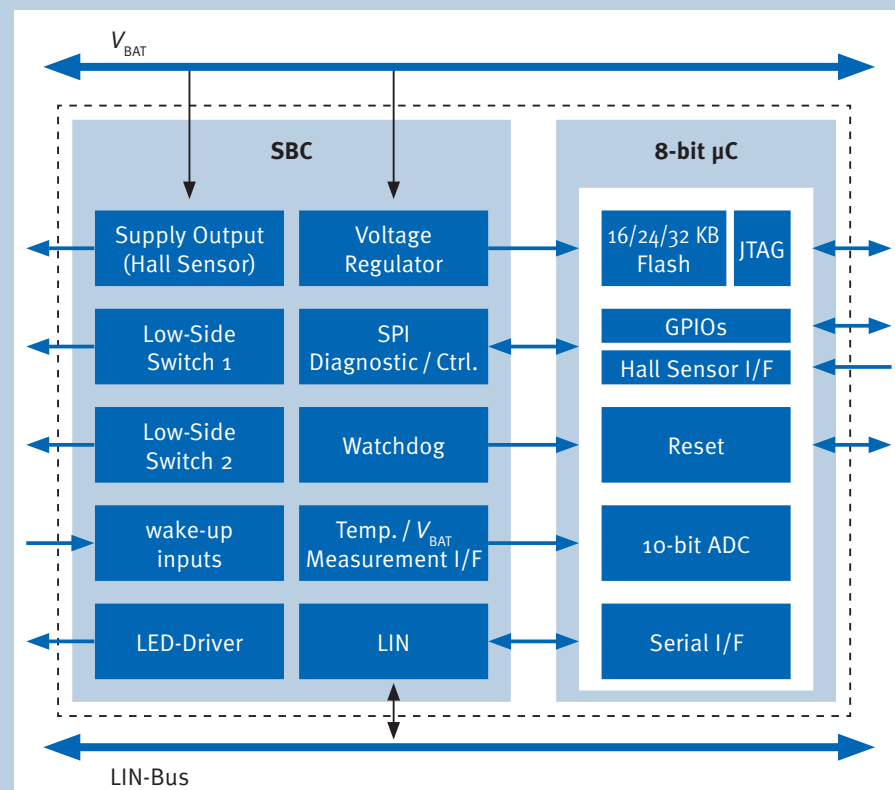

# Your Partner of Choice for Automotive Communication Interfaces

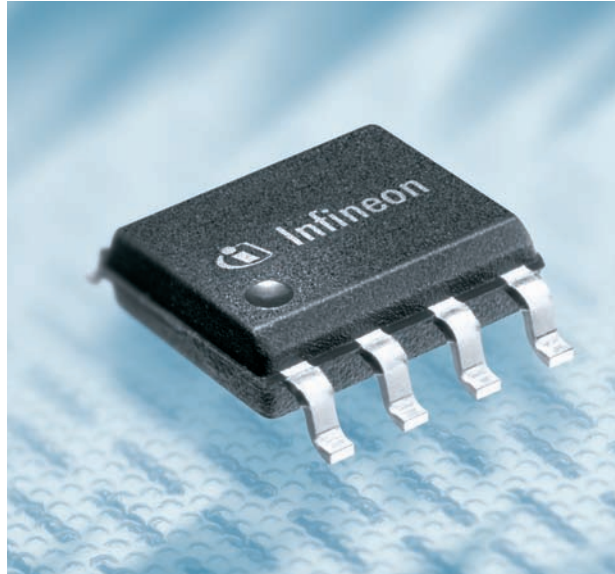
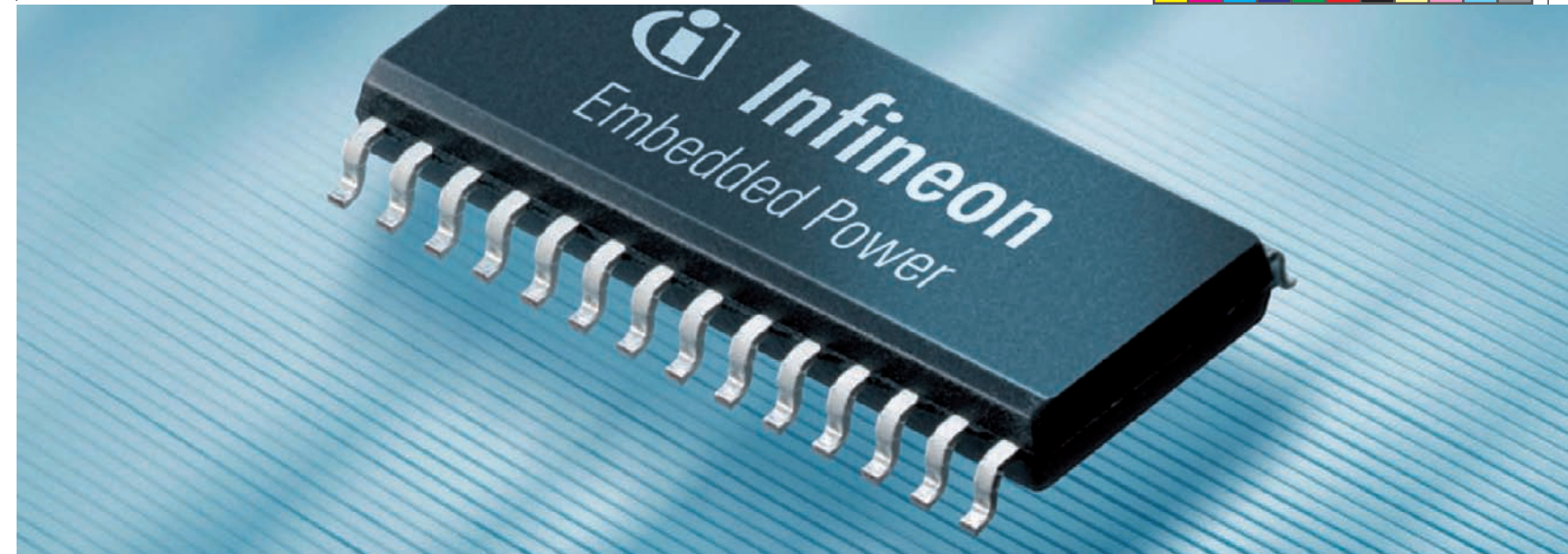

WORLD LEADER IN AUTOMOTIVE electronics for 35 years, Infineon focuses on the in-vehicle networking, a major driver today for innovation in the automotive field, meeting the ever-increasing demands of consumers for comfort, performance and safety.

WITH OVER TEN YEARS' EXPERIENCE developing communication interfaces, Infineon offers an extensive product line of transceivers, system basis chips and Embedded Power solutions for CAN and LIN protocols, from the mature to the advanced.

CONTINUOUSLY IMPROVING ITS SPT chip technology, Infineon provides solutions for the challenges faced by the automotive industry, featuring the best ESD and EMC combined performances.

IN THIS BROCHURE Infineon introduces its transceivers and system basis chips portfolio, with a detailed description of their distinctive key functions and benefits.

THE PRODUCT BRIEFS INCLUDED provide a comprehensive overview of current products, as well as the latest product proposals.

FOR MORE DETAILED INFORMATION visit the Infineon website at [www.infineon.com/transceivers](http://www.infineon.com/transceivers) or contact your sales partner listed on the back of this brochure.

## Embedded Power – Relay Driver ICs – TLE78xx: Application Example

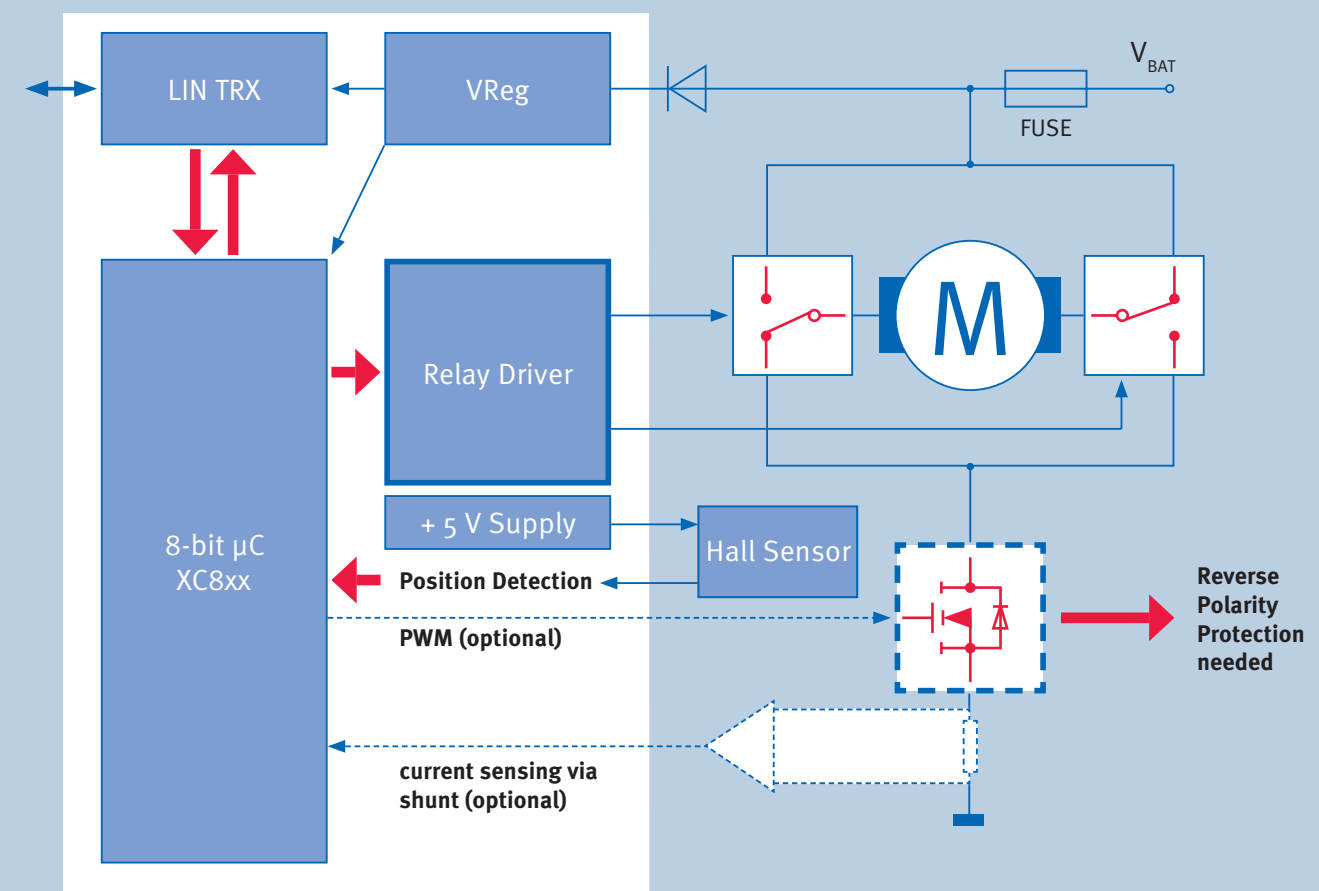

### Tool Support for ePower Relay Driver

- Evaluation Board TLE78xx
  - Power & LIN Interface
  - JTAG Connector (debugging / programming)
  - Switch Inputs, Relay, LEDs available
- 8-Bit  $\mu$ C XC8xx:
  - KEIL  $\mu$ Vision C-Compiler, Assembler, Debugger and Programmer for Flash Memory
  - GNU "Open Source" Tools available
  - KEIL Real Time Operating System RTX51

### Application

- Window Lift Module
- Seat module
- Sun-roof module

# INFINEON TECHNOLOGIES SALES OFFICES WORLDWIDE\*

(COUNTRY/AREA)

**Australia**  
Infineon Technologies Australia Pty. Ltd.  
885 Mountain Highway  
**Bayswater, Victoria 3153**  
☎ (+61) 3-97 21 88 88  
Fax (+61) 3-97 21 88 08

**Austria**  
Infineon Technologies Austria AG  
Production / Development Center  
Siemensstraße 2  
**9500 Villach**  
☎ (+43) 5-17 77 0  
Fax (+43) 5-17 77 35 01

Infineon Technologies Austria AG  
Opengasse 200B /31  
**1040 Wien**  
☎ (+43) 1-51 77 71 11 00  
Fax (+43) 1-51 77 71 15 00

**Belgium / Luxembourg Netherlands**  
Infineon Technologies Holding B.V.  
Generaal  
Lemanstraat 67  
**2018 Antwerpen**  
☎ (+31) 10-21 76 80 0  
Fax (+31) 10-21 76 81 9

Infineon Technologies Holding B.V.  
Westblaak 32  
**3012 KM Rotterdam**  
☎ (+31) 10-21 76 80 0  
Fax (+31) 10-21 76 81 9

**Brazil**  
Infineon Technologies  
South America Ltda.  
Avenida Paulista,  
n° 1337-CJ 172  
**01311-200 Cerqueira Cesar São Paulo**  
☎ (+55) 11-33 72 92 40  
Fax (+55) 11-33 72 92 30

**Canada**  
Infineon Technologies  
North America Corp.  
340 March Road, Suite 301  
**Kanata, Ontario K2K 2E2**  
☎ (+1) 866-95 19 51 95 1  
Fax (+1) 613-59 18 95 4

**China**  
Infineon Technologies  
Center of Competence (Shanghai) Co., Ltd.  
12th Floor, Quantum Plaza  
No.27 Zhi Chun Road  
Haidian District  
**Beijing 100083**  
☎ (+86) 10-82 35 61 18  
Fax (+86) 10-82 35 54 74

Infineon Technologies  
Hong Kong Ltd.  
Suite 302, Level 3 Festival Walk  
80 Tat Chee Avenue  
Kowloon Tong,  
**Hong Kong**  
☎ (+852) 28-22 05 00  
Fax (+852) 28-27 97 62

Infineon Technologies  
International Trade (Shanghai) Co., Ltd.  
No. 7 & 8, Lane 647, Song Tao Road  
Zhang Jian Hi-Tech Park  
**Shanghai 201203**  
☎ (+86) 21-61 01 90 00  
Fax (+86) 21-50 80 62 04

Infineon Technologies  
China Co., Ltd.  
Shenzhen Office, Room 1502, Block A  
Tian An International Building  
Renmin Nan Road  
**Shenzhen 518 001**  
☎ (+86) 755-22 19 24 00  
Fax (+86) 755-82 28 02 17

Infineon Technologies  
Taiwan Co., Ltd.  
12F-1, No. 3-2 Yuan Qu Street,  
Nan Kang District  
**Taipei 115**  
☎ (+886) 2-26 55 75 00  
Fax (+886) 2-26 55 75 01 8

**Denmark**  
Infineon Technologies Nordic AB  
Herlev Hovedgade 201A  
**2730 Herlev**  
☎ (+45) 44-50 77 00  
Fax (+45) 44-50 77 01

**Finland**  
Infineon Technologies Nordic AB  
Visitor's Address Upseerinkatu 1  
P.O. Box 276  
**02601 Espoo**  
☎ (+358) 10-6 80 84 00  
Fax (+358) 10-6 80 84 01

**France**  
Infineon Technologies France S.A.S.  
Centre de vie Agora – Bat. A2  
Z.I. des Paluds  
**13400 Aubagne**  
☎ (+33) 44-28 24 61 0  
Fax (+33) 44-28 24 61 8

Infineon Technologies France S.A.S.  
Burolines 2  
2 ter, rue Marcel Doret  
**31700 Blagnac**  
☎ (+33) 5-34 55 13 30  
Fax (+33) 5-34 55 13 34

Infineon Technologies France S.A.S.  
39-47, Boulevard Ormano  
**93527 Saint-Denis CEDEX 2**  
☎ (+33) 1-48 09 72 00  
Fax (+33) 1-48 09 72 90

**Germany**  
Comneon GmbH  
Südwestpark 2-4  
**90449 Nuremberg**  
☎ (+49) 911-37 88 0  
Fax (+49) 911-37 88 10 00

Hfitec Development Tools GmbH  
Greschbachstraße 12  
**76229 Karlsruhe**  
☎ (+49) 72-19 62 80  
Fax (+49) 72-19 62 81 89

Infineon Technologies AG  
Siemensstraße 31-33  
**71254 Ditzingen / Stuttgart**  
☎ (+49) 7156-17 91 90  
Fax (+49) 7156- 17 91 99 0

Infineon Technologies AG  
Düsseldorfer Landstraße 401,  
**47259 Duisburg**  
☎ (+49) 203-72 98 71 1  
Fax (+49) 203-72 98 76 0

Infineon Technologies AG  
Naegelbacherstraße 26  
**91052 Erlangen**  
☎ (+49) 9131-97 00 10  
Fax (+49) 9131-97 00 19 9

Infineon Technologies A  
Lindenplatz 2  
**20099 Hamburg**  
☎ (+49) 40-23 51 94 74  
Fax (+49) 40-23 51 94 75

Infineon Technologies AG  
Paderborner Straße 1  
**30539 Hannover**  
☎ (+49) 511-87 65 62 0  
Fax (+49) 511-87 65 62 90

Infineon Technologies AG  
Am Campeon 1-12  
**85579 Neubiberg**  
☎ (+49) 89-23 40  
Fax (+49) 89-23 42 46 94

Infineon Technologies AG  
Südwestpark 65  
**90449 Nuremberg**  
☎ (+49) 911-25 29 30  
Fax (+49) 911-25 29 39 3

Infineon Technologies AG  
Max-Planck-Straße 5  
**59581 Warstein**  
☎ (+49) 2902-76 40  
Fax (+49) 2902-76 41 25 6

**Hungary**  
Infineon Technologies Cegléd Kft.  
Gizella u. 51-57  
**1143 Budapest**  
☎ (+36) 1-47 12 82 4  
Fax (+36) 1-47 12 82 5

**India**  
Infineon Technologies  
India Pvt. Ltd.  
10th Floor, Discoverer Building  
International Technology Park  
Whitefield Road  
**Bangalore 560 066**  
☎ (+91) 80-41 39 20 01  
Fax (+91) 80-41 39 23 33

**Iran**  
Siemens SSK  
No. 32 Taleghani Ave.  
**15875-4773 Teheran**  
☎ (+98) 2-16 14 23 17  
Fax (+98) 2-16 46 30 60

**Ireland**  
Infineon Technologies Ireland Ltd.  
69 Fitzwilliam Lane  
**Dublin 2**  
☎ (+353) 1-79 99 50 0  
Fax (+353) 1-79 99 50 1

**Israel**  
Nisko Ltd.  
2 A, Habarzel Street  
**Tel Aviv 69710**  
☎ (+972) 3-76 57 30 0  
Fax (+972) 3-76 57 33 3

**Italy**  
Infineon Technologies Italia S.r.l.  
Via Vipleno, 4  
**20128 Milan**  
☎ (+39) 2-25 20 41  
Fax (+39) 2-25 20 44 39 5

**Japan**  
Infineon Technologies Japan K.K.  
Gate City Osaki, East Tower  
21F /22F /23F  
**111-2 Osaki Shinagawa-ku Tokyo 141-0032**  
☎ (+81) 3-57 45 71 00  
Fax (+81) 3-57 45 74 10

Infineon Technologies Japan K.K.  
Maruyama Nissel Building 14F  
2-14-21 Nishiki, Naka-ku  
**Nagoya-shi, Aichi 460-0003**  
☎ (+81) 52-22 31 57 0  
Fax (+81) 52-22 31 46 1

Infineon Technologies Japan K.K.  
ORIX-Dojima Building 8F  
2-1-31, Dojima, Kita-ku  
Osaka-shi,  
**Osaka 530-0003**  
☎ (+81) 6-47 97 44 60  
Fax (+81) 6-47 97 44 62

**Korea**  
Infineon Technologies Korea Co., Ltd.  
4th Floor Sigma Tower  
7-19 Shincheon-dong Songpa-gu  
**Seoul 138-734**  
☎ (+82) 2-34 60 09 50  
Fax (+82) 2-34 60 09 01

Infineon Technologies Korea Co., Ltd.  
15th Floor SI Technoville 60-19  
Gasandong Geumcheongu  
**Seoul 153-801**  
☎ (+82) 2-34 60 08 80  
Fax (+82) 2-34 60 09 09

**Mexico**  
Everest Sales & Solutions  
Av. Manuel Acuña 2674-101  
Col. Ladrón de Guevara  
**44680 Guadalajara, J. AL**  
☎ (+52) 33-36 42 21 01  
Fax (+52) 33-36 40 65 62

**Poland**  
Siemens Sp. z o.o.  
Ul. Zupnicza 11  
**03-821 Warsaw**  
☎ (+48) 22-87 09 15 0  
Fax (+48) 22-87 09 15 9

**Puerto Rico**  
Klamco Electronics  
527 Street QH No. 1  
Country Club  
**Carolina, PR 00982**  
☎ (+1787) 257-79 22  
Fax (+1787) 257-79 61

**Russia**  
Infineon Technologies RUSS LLC  
Leninsky prospect 113 / 1  
**117 198 Moscow**  
☎ (+7) 495-95 65 19 5  
Fax (+7) 495-95 65 19 5

**Singapore**  
Infineon Technologies Asia  
Pacific Pte. Ltd.  
8 Kallang Sector  
**Singapore 349 282**  
☎ (+65) 68-76 28 88  
Fax (+65) 68-76 31 22

**South Africa**  
Siemens Components  
P.O. Box 3438  
Halfway House 1680  
**2146 Sandton**  
☎ (+27) 11-70 66 09 9  
Fax (+27) 11-70 69 04 9

**Spain**  
Infineon Distribution Sales Office IBERIA  
c/ Chile, 10 12 Planta – Oficina 141  
Edificio Madrid 92  
**28290 Las Rozas de Madrid, Madrid**  
☎ (+34) 91-63 05 72 8  
Fax (+34) 91-63 05 72 8

Siemens, S.A.  
División de Componentes  
Ronda de Europa, 5  
**28760 Tres Cantos-Madrid**  
☎ (+34) 91-51 47 15 5  
Fax (+34) 91-51 47 01 4

**Sweden**  
Infineon Technologies Sweden AB  
Isafjordsgatan 16  
**164 81 Kista**  
☎ (+46) 8-75 75 00 0  
Fax (+46) 8-75 74 61 2

**Switzerland**  
Infineon Technologies  
Schweiz AG  
Badener Strasse 623  
P.O. Box 1570  
**8048 Zürich**  
☎ (+41) 1-49 78 04 0  
Fax (+41) 1-49 78 05 0

**Turkey**  
Infineon Technologies Turkey  
Sahit Mehmet Fatih Ongul Sok.  
Bagdatlioglu Plaza No:3  
Office-4, Kozyatagi  
**34742 Kozyatagi, Istanbul**  
☎ (+90) 216-46 40 75 5  
Fax (+90) 216-46 40 75 6

**United Kingdom**  
Infineon House  
Great Western Court  
Hunts Ground Road  
Stoke Gifford  
**BRISTOL BS34 8HP**  
☎ (+44) 11-79 52 88 23

Infineon Technologies  
Kingswood  
Kings Ride  
**Ascot SL5 8AD**  
☎ (+44) 1344 865900

**U.S.A.**  
Infineon Technologies  
North America Corp.  
2529 Commerce Drive, Suite H  
**Kokomo, IN 46902**  
☎ (+1) 765-45 61 92 8  
Fax (+1) 765-45 63 83 6

Infineon Technologies  
Industrial Power, Inc.  
1050 Route 22  
**Lebanon, NJ 08833**  
☎ (+1) 908-23 65 62 1  
Fax (+1) 908-23 65 62 0

Infineon Technologies  
North America Corp.  
19111 Victor Parkway  
**Livonia, MI 48152**  
☎ (+1) 734-77 95 00 0  
Fax (+1) 734-77 95 00 1

Infineon Technologies  
North America Corp.  
12770 High Bluff Drive, Suite 100  
**San Diego, CA 92130**  
☎ (+1) 858-50 92 16 0  
Fax (+1) 858-50 92 16 1

Infineon Technologies  
North America Corp.  
640 N. McCarthy Blvd.  
**Milpitas, CA 95035**  
☎ (+1) 866-95 19 51 9

## The Robust Path to Automotive Networks

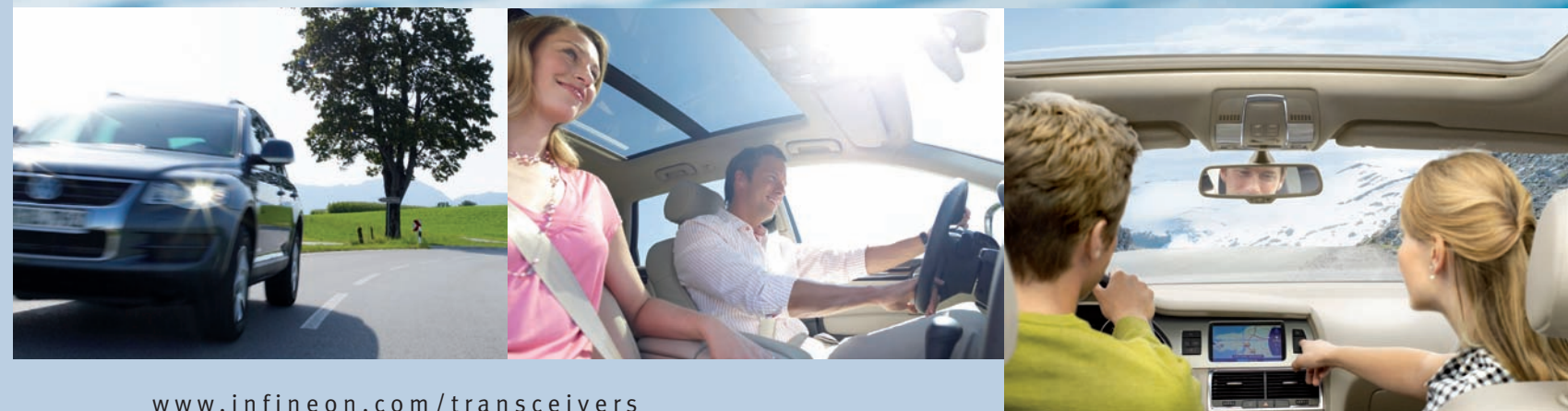
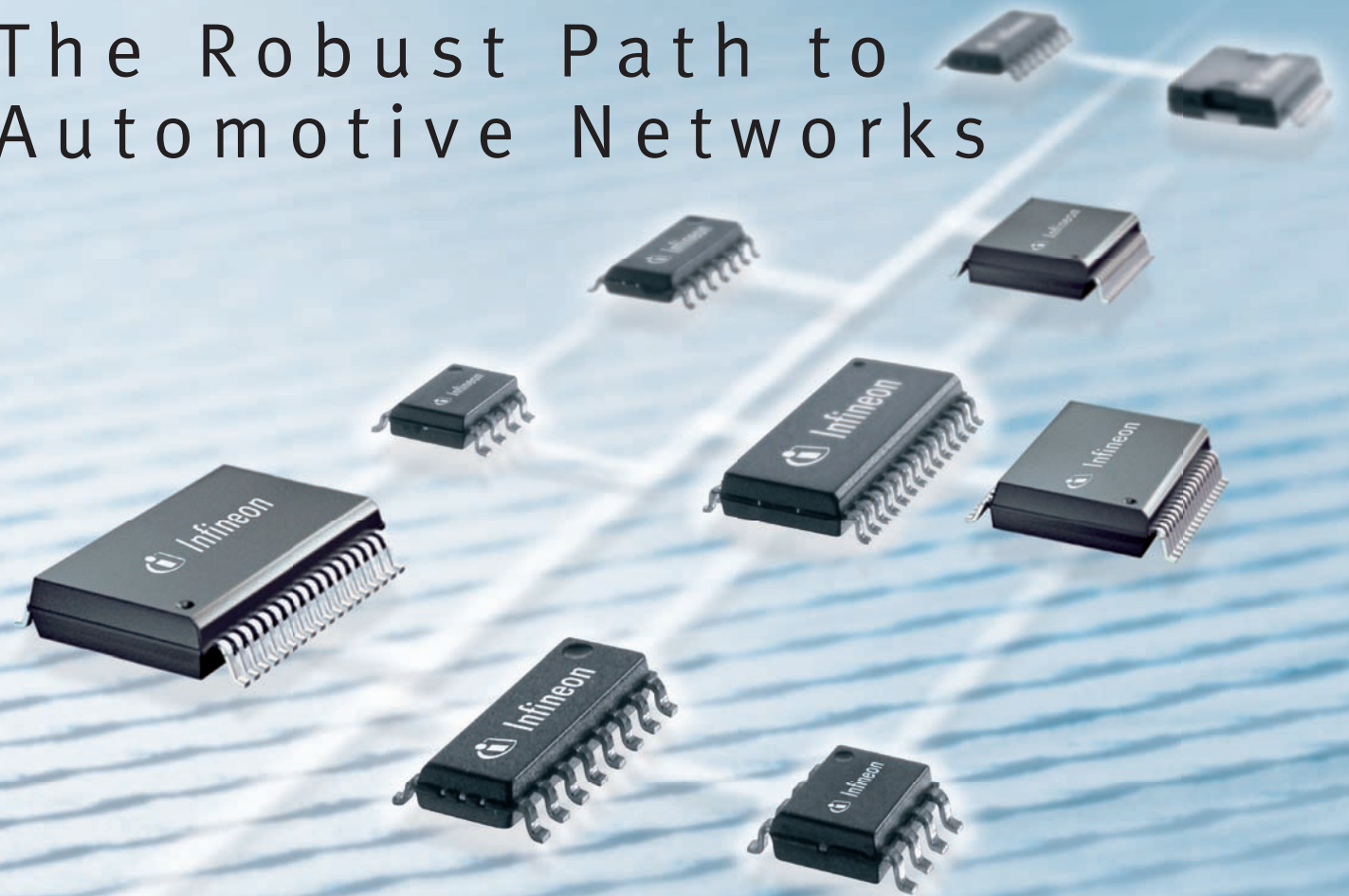

[www.infineon.com/transceivers](http://www.infineon.com/transceivers)

\* and representative offices

**Edition 2008**  
Published by  
**Infineon Technologies AG**  
81726 Munich, Germany  
© 2008 Infineon Technologies AG  
All rights reserved.



Order no. B152-H8619-G1-X-7600



Never stop thinking

## Looking for pricing, stock, or lifecycle information?

Click below to explore more details on WIN SOURCE:

-  [View TLE8262-2E on WIN SOURCE](#)
-  [Infineon Technologies](#) Information

## Optimize Your Supply Chain with WIN SOURCE Solutions

-  Global Sourcing Solution
-  Obsolete Management
-  Cost Control Management
-  Shortage Management
-  Alternative Solution
-  Excess Inventory Management