



# THE DATASHEET OF SN74LS294N



## SN74LS29x Programmable Frequency Dividers and Digital Timers

### 1 Features

- Count Divider Chain
- Digitally Programmable from  $2^2$  to  $2^n$  ( $n = 31$  for SN74LS292,  $n = 15$  for SN74LS294)
- Useable Frequency Range from DC to 30 MHz
- Easily Expandable

### 2 Applications

- Frequency Division
- Digital Timing

### 3 Description

The SN74LS29x devices are programmable frequency dividers and digital timers contain 31 flip-flops plus 30 gates (in SN74LS292) or 15 flip-flops plus 29 gates (in SN74LS294) on a single chip. The count modulo is under digital control of the inputs provided.

Both types feature an active-low  $\overline{\text{CLR}}$  clear input to initialize the state of all flip-flops. To facilitate the incoming inspection, test points are provided (TP1, TP2, and TP3 on the SN74LS292, and TP on the SN74LS294). These test points are not intended to drive system loads. Both types feature two clock inputs; either one may be used for clock gating (see [Table 1](#)).

A brief look at the digital timing capabilities of the SN74LS292 shows that with a 1-MHz input frequency, programming for  $2^{10}$  gives a period of 1.024 ms,  $2^{20}$  gives a period of 1.05 sec,  $2^{26}$  gives a period of 1.12 min, and  $2^{31}$  gives a period of 35.79 min.

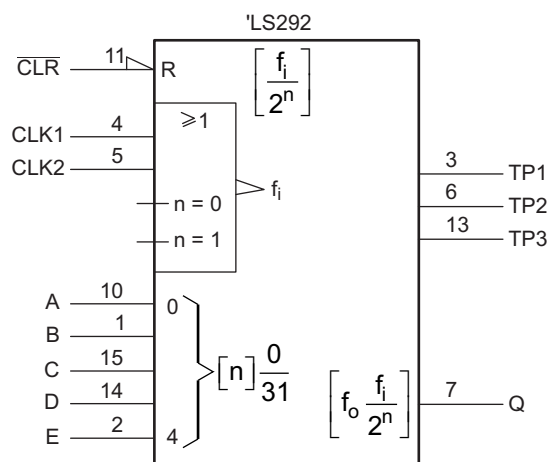
These devices are easily cascadable, giving limitless possibilities to achievable timing delays.

#### Device Information<sup>(1)</sup>

PART NUMBER	PACKAGE	BODY SIZE (NOM)
SN74LS292N	PDIP (16)	6.35 mm x 19.30 mm
SN74LS294N		

(1) For all available packages, see the orderable addendum at the end of the data sheet.

#### Logic Symbols



## Table of Contents

<b>1 Features</b> .....	<b>1</b>	8.3 Feature Description .....	<b>10</b>
<b>2 Applications</b> .....	<b>1</b>	8.4 Device Functional Modes .....	<b>10</b>
<b>3 Description</b> .....	<b>1</b>	<b>9 Application and Implementation</b> .....	<b>13</b>
<b>4 Revision History</b> .....	<b>2</b>	9.1 Application Information .....	<b>13</b>
<b>5 Pin Configuration and Functions</b> .....	<b>3</b>	9.2 Typical Application .....	<b>13</b>
<b>6 Specifications</b> .....	<b>4</b>	<b>10 Power Supply Recommendations</b> .....	<b>14</b>
6.1 Absolute Maximum Ratings .....	<b>4</b>	<b>11 Layout</b> .....	<b>14</b>
6.2 Recommended Operating Conditions .....	<b>4</b>	11.1 Layout Guidelines .....	<b>14</b>
6.3 Thermal Information .....	<b>5</b>	11.2 Layout Example .....	<b>14</b>
6.4 Electrical Characteristics .....	<b>5</b>	<b>12 Device and Documentation Support</b> .....	<b>15</b>
6.5 Switching Characteristics .....	<b>5</b>	12.1 Documentation Support .....	<b>15</b>
6.6 Typical Characteristics .....	<b>6</b>	12.2 Related Links .....	<b>15</b>
<b>7 Parameter Measurement Information</b> .....	<b>7</b>	12.3 Community Resources .....	<b>15</b>
7.1 Logic Diagrams .....	<b>7</b>	12.4 Trademarks .....	<b>15</b>
<b>8 Detailed Description</b> .....	<b>10</b>	12.5 Electrostatic Discharge Caution .....	<b>15</b>
8.1 Overview .....	<b>10</b>	12.6 Glossary .....	<b>15</b>
8.2 Functional Block Diagram .....	<b>10</b>	<b>13 Mechanical, Packaging, and Orderable Information</b> .....	<b>15</b>

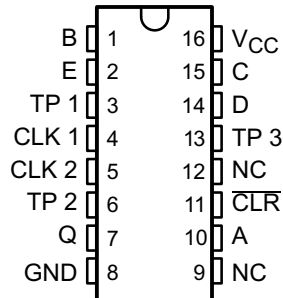
## 4 Revision History

NOTE: Page numbers for previous revisions may differ from page numbers in the current version.

<b>Changes from Original (January 1981) to Revision A</b>	<b>Page</b>
• Removed SN54LS292 and SN54LS294 from the data sheet .....	<b>1</b>
• Added <i>ESD Ratings</i> and <i>Thermal Information</i> tables, <i>Feature Description</i> section, <i>Device Functional Modes</i> section, <i>Application and Implementation</i> section, <i>Power Supply Recommendations</i> section, <i>Layout</i> section, <i>Device and Documentation Support</i> section, and <i>Mechanical, Packaging, and Orderable Information</i> section. ....	<b>1</b>

## 5 Pin Configuration and Functions

**SN74LS29x J, W, or N Package  
16-Pin PDIP  
Top View**



**Pin Functions, SN74LS292**

PIN		I/O	DESCRIPTION
NAME	PDIP		
A	10	I	Programming input A
B	1	I	Programming input B
C	15	I	Programming input C
CLK1	4	I	Clock 1 input
CLK2	5	I	Clock 2 input
$\overline{\text{CLR}}$	11	I	Active-low clear input
D	14	I	Programming input D
E	2	I	Programming input E
GND	8	-	Ground
NC	9, 12	-	No connect
Q	7	O	Q Output
TP	—	O	Test Point
TP1	3	O	Test Point
TP2	6	O	Test Point
TP3	13	O	Test Point
V <sub>CC</sub>	16	-	Power

**Pin Functions, SN74LS294**

PIN		I/O	DESCRIPTION
NAME	PDIP		
A	2	I	Programming input A
B	1	I	Programming input B
C	15	I	Programming input C
CLK1	4	I	Clock 1 input
CLK2	5	I	Clock 2 input
$\overline{\text{CLR}}$	11	I	Active-low clear input
D	14	I	Programming input D
E	—	I	Programming input E
GND	8	-	Ground
NC	6, 9, 10, 12, 13	-	No connect
Q	7	O	Q Output
TP	3	O	Test Point
TP1	—	O	Test Point
TP2	—	O	Test Point
TP3	—	O	Test Point
V <sub>CC</sub>	16	-	Power

## 6 Specifications

### 6.1 Absolute Maximum Ratings

 over operating free-air temperature range (unless otherwise noted)<sup>(1)</sup>

		MIN	MAX	UNIT
V <sub>CC</sub> <sup>(2)</sup>	Supply voltage		7	V
	Input voltage		7	V
T <sub>J</sub>	Junction temperature		150	°C
T <sub>stg</sub>	Storage temperature	-65	150	°C

(1) Stresses beyond those listed under *Absolute Maximum Ratings* may cause permanent damage to the device. These are stress ratings only, which do not imply functional operation of the device at these or any other conditions beyond those indicated under *Recommended Operating Conditions*. Exposure to absolute-maximum-rated conditions for extended periods may affect device reliability.

(2) Voltage values are with respect to network ground terminal.

### 6.2 Recommended Operating Conditions

over operating free-air temperature range (unless otherwise noted)

		MIN	NOM	MAX	UNIT
V <sub>CC</sub>	Supply voltage	4.75	5	5.25	V
V <sub>IH</sub>	High-level input voltage	2			V
V <sub>IL</sub>	Low-level input voltage			0.8	V
I <sub>OH</sub>	High-level output current (Q only)			-1.2	mA
I <sub>OL</sub>	Low-level output current (Q only)			24	mA
f <sub>clock</sub>	Clock frequency	0		30	MHz
t <sub>w</sub>	Duration of clock input pulse	16			ns
t <sub>w</sub>	Duration of clear pulse	SN74LS292	55		ns
		SN74LS294	35		
t <sub>SU</sub>	Clear inactive-state set-up time	15			ns
T <sub>A</sub>	Operating free-air temperature	0		70	°C

### 6.3 Thermal Information

THERMAL METRIC <sup>(1)</sup>		SN74LS292	UNIT
		N (PDIP)	
		16 PINS	
R <sub>θJA</sub>	Junction-to-ambient thermal resistance	36.8	°C/W
R <sub>θJC(top)</sub>	Junction-to-case (top) thermal resistance	22.2	°C/W
R <sub>θJB</sub>	Junction-to-board thermal resistance	17.0	°C/W
ψ <sub>JT</sub>	Junction-to-top characterization parameter	7.0	°C/W
ψ <sub>JB</sub>	Junction-to-board characterization parameter	16.8	°C/W

(1) For more information about traditional and new thermal metrics, see the *Semiconductor and IC Package Thermal Metrics* application report, [SPRA953](#).

### 6.4 Electrical Characteristics

over operating free-air temperature range (unless otherwise noted)

PARAMETER		TEST CONDITIONS <sup>(1)</sup>	MIN	TYP <sup>(2)</sup>	MAX	UNIT	
V <sub>IK</sub>		V <sub>CC</sub> = MIN, I <sub>I</sub> = -18 mA			-1.5	V	
V <sub>OH</sub>	Q	V <sub>CC</sub> = MIN, V <sub>IH</sub> = 2 V, I <sub>OH</sub> = -1.2 mA, V <sub>IL</sub> = MAX	2.4	3.4		V	
V <sub>OL</sub>	Q	V <sub>CC</sub> = MIN, V <sub>IH</sub> = 2 V, V <sub>IL</sub> = MAX		I <sub>OL</sub> = 12 mA	0.25	0.4	V
				I <sub>OL</sub> = 24 mA	0.35	0.5	
				I <sub>OL</sub> = 0.5 mA	0.25	0.4	
I <sub>I</sub>		V <sub>CC</sub> = MAX, V <sub>I</sub> = 7 V			0.1	mA	
I <sub>IH</sub>		V <sub>CC</sub> = MAX, V <sub>I</sub> = 2.7 V			20	mA	
I <sub>IL</sub>	CLK1, CLK2	V <sub>CC</sub> = MAX, V <sub>I</sub> = 0.4 V			-0.8	mA	
	All others	V <sub>CC</sub> = MAX, V <sub>I</sub> = 0.4 V			-0.4		
I <sub>OS</sub> <sup>(4)</sup>	Q	V <sub>CC</sub> = MAX	-30		-130	mA	
I <sub>CC</sub>	SN74LS292	V <sub>CC</sub> = MAX, all inputs grounded, all outputs open		40	75	mA	
	SN74LS294	V <sub>CC</sub> = MAX, all inputs grounded, all outputs open		30	50		

(1) For conditions shown as MIN or MAX, use the appropriate value specified under *Recommended Operating Conditions*.

(2) All typical values are at V<sub>CC</sub> = 5 V, T<sub>A</sub> = 25°C.

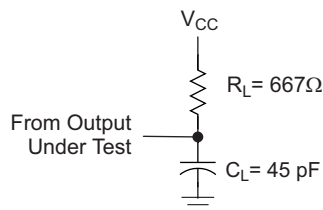
(3) The TP output or outputs are not intended to drive external loads, but are solely provided for test points.

(4) The duration of the short-circuit should not exceed one second.

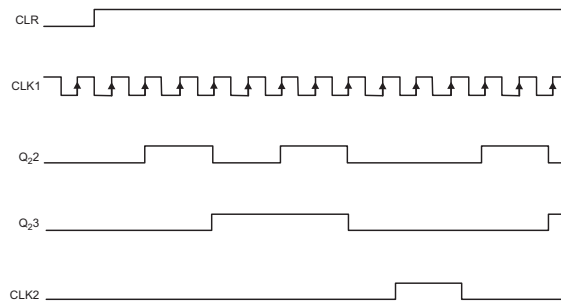
### 6.5 Switching Characteristics

V<sub>CC</sub> = 5 V, T<sub>A</sub> = 25°C, R<sub>L</sub> = 667 Ω, C<sub>L</sub> = 45 pF (see [Figure 1](#))

PARAMETER	TEST CONDITIONS	MIN	TYP	MAX	UNIT
f <sub>max</sub>	From CLK1 or 2	30	50		MHz
t <sub>PLH</sub>	From CLK1 or 2, to Q; Modulo set at 2 <sup>2</sup> , A through # = LLLHL (xxxxLS292), A through D = LLHL (xxxxLS294)		55	90	ns
t <sub>PHL</sub>	From CLK1 or 2, to Q; Modulo set at 2 <sup>2</sup> , A through # = LLLHL (xxxxLS292), A through D = LLHL (xxxxLS294)		80	120	ns
	From $\overline{\text{CLR}}$ , to Q	SN74LS292	85	130	
		SN74LS294	35	65	

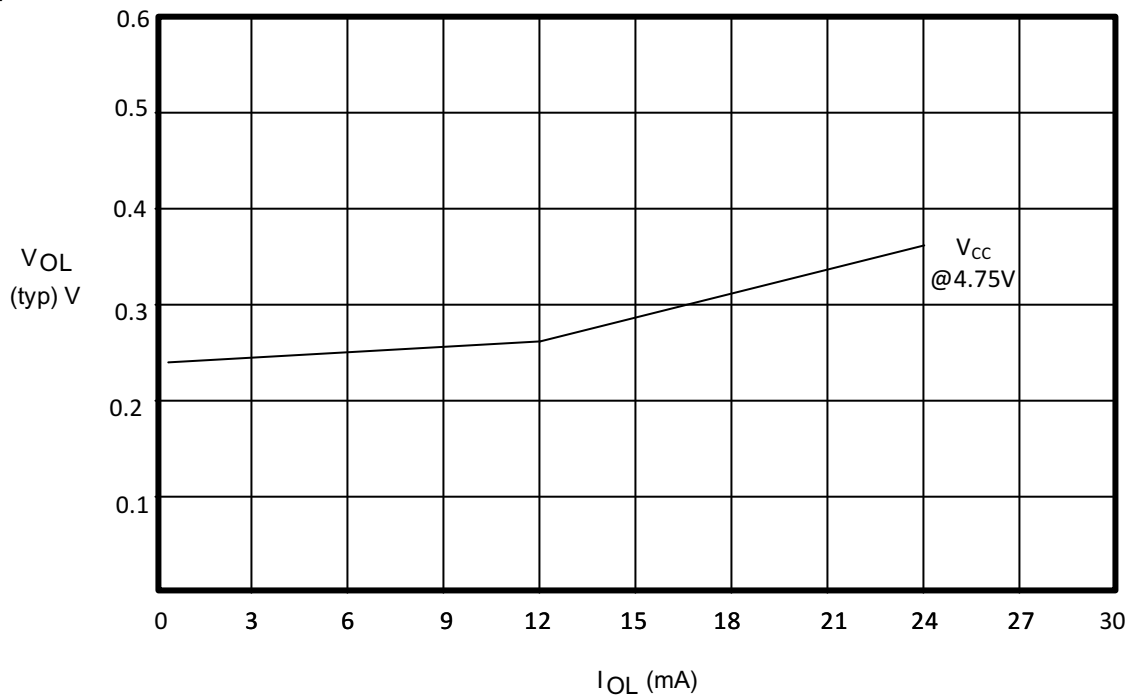


**Figure 1. Switching Loads**



**Figure 2. Timing Diagram**

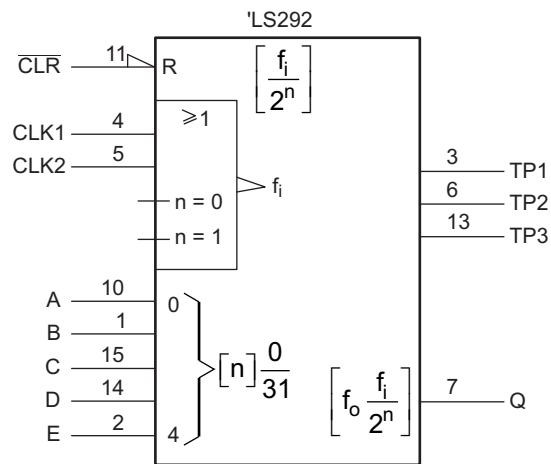
**6.6 Typical Characteristics**



**Figure 3.  $V_{OL}$  vs  $I_{OL}$**

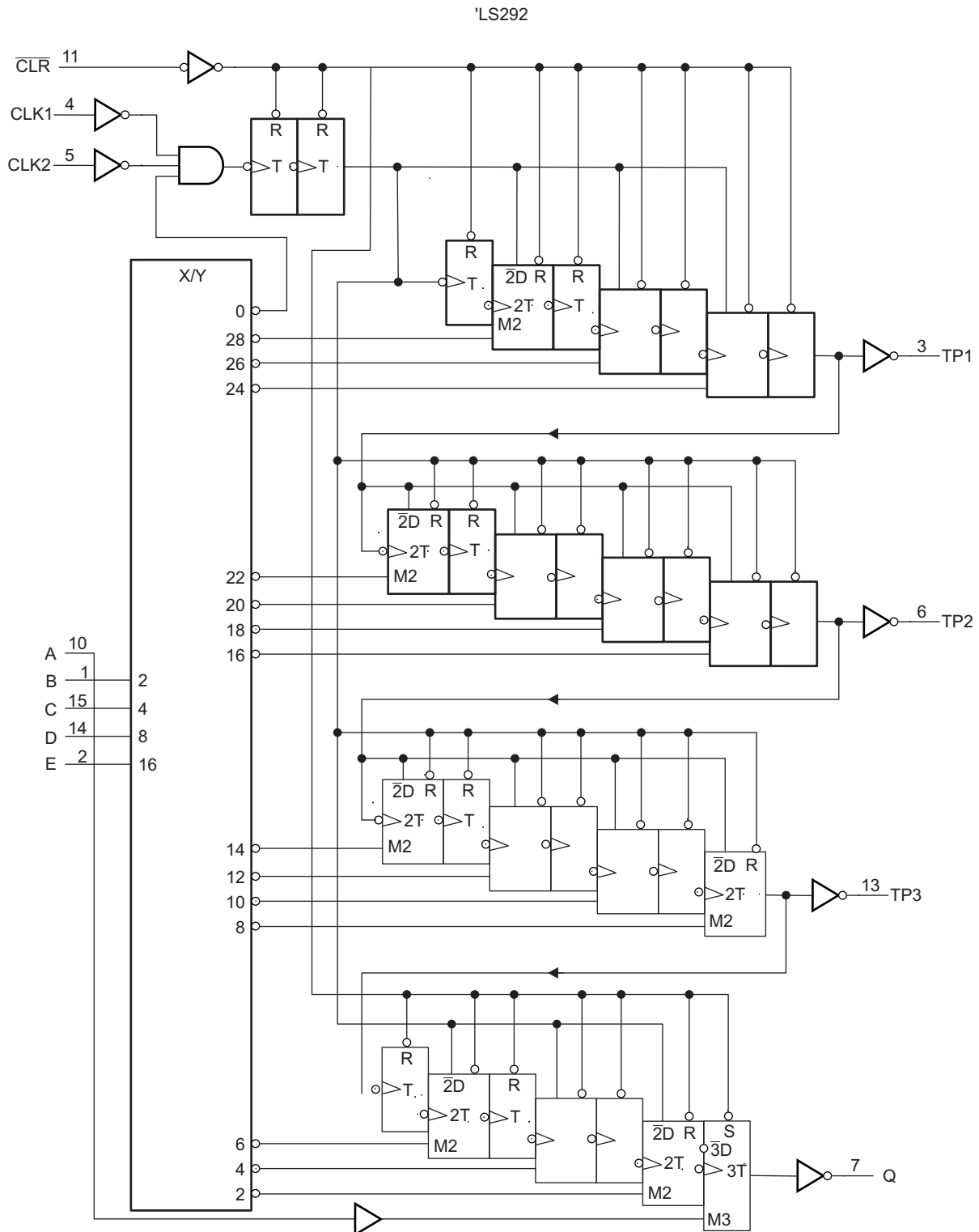
## 7 Parameter Measurement Information

### 7.1 Logic Diagrams



These symbols are in accordance with ANSI/IEEE Std 91-1984 and IEC Publication 617-12. Pin numbers shown are for J, N, and W packages.

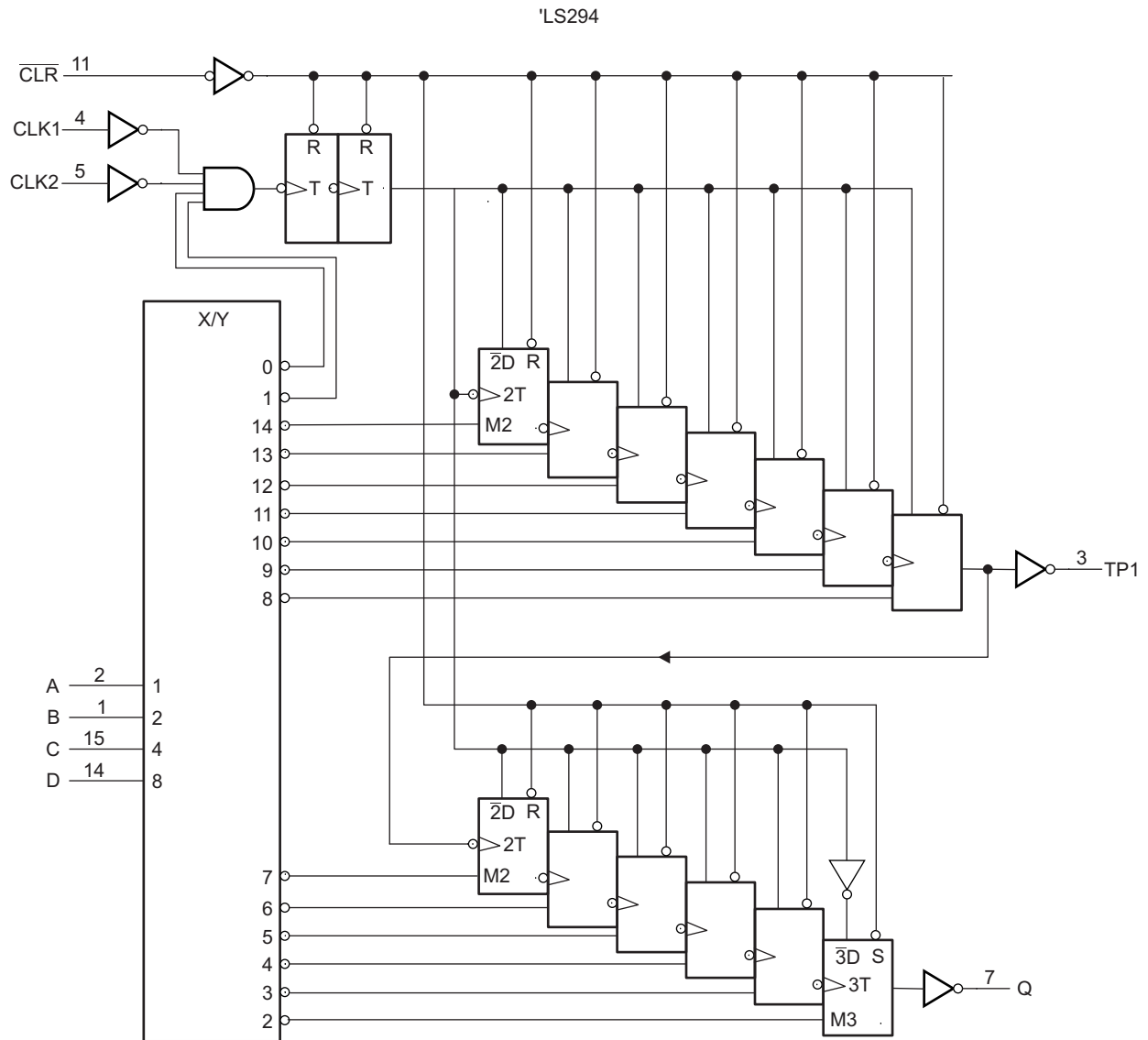
**Figure 4. Logic Symbols**

**Logic Diagrams (continued)**


Pin numbers shown are for J, N, and W packages.

**Figure 5. Logic Diagram (Positive Logic) SN74LS292**

Logic Diagrams (continued)



Pin numbers shown are for J, N, and W packages.

Figure 6. Logic Diagram (Positive Logic) SN74LS294

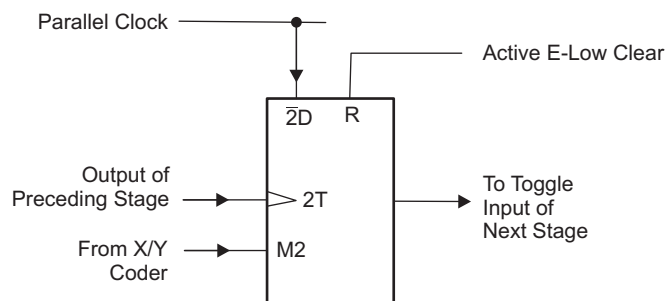
## 8 Detailed Description

### 8.1 Overview

*Functional Block Diagram* shows that the count modulo is controlled by an X/Y decoder connected to the mode control inputs of several flip-flops. These flip-flops with mode controls each have a D input connected to the parallel clock line, and a T input driven by the preceding stage. The parallel clock frequency is always the input frequency divided by four.

The X/Y decoder output selected by the programming inputs goes low. While a mode control is slow, the D input of that flip-flop is enabled, and the signal from the parallel clock line ( $f_{in} \div 4$ ) is passed to the T input of the following stage. All the other mode controls are high, enabling the T inputs and causing each flip-flop in turn to divide by two.

### 8.2 Functional Block Diagram



### 8.3 Feature Description

This SN74LS29x device can be used to digitally program from  $2^2$  to  $2^n$  ( $n = 31$  for SN74LS292,  $n = 15$  for SN74LS294) divider chain. This has a useable frequency range up to 30 MHz. The flexibility is offered when the devices are cascaded to have desired timing delay.

### 8.4 Device Functional Modes

[Table 1](#), [Table 2](#), and [Table 3](#) list the functional modes of the SN74LS292.

**Table 1. Function Table**

CLEAR	CLK1	CLK2	Q OUTPUT MODE
L	X	X	Cleared to L
H	↑	L	Count
H	L	↑	Count
H	H	X	Inhibit
H	X	H	Inhibit

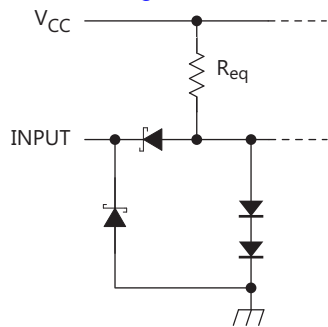
**Table 2. SN74LS292 Function Table**

PROGRAMMING INPUTS					FREQUENCY DIVISION							
					Q		TP1		TP2		TP3	
E	D	C	B	A	BINARY	DECIMAL	BINARY	DECIMAL	BINARY	DECIMAL	BINARY	DECIMAL
L	L	L	L	L	Inhibit	Inhibit	Inhibit	Inhibit	Inhibit	Inhibit	Inhibit	Inhibit
L	L	L	L	H	Inhibit	Inhibit	Inhibit	Inhibit	Inhibit	Inhibit	Inhibit	Inhibit
L	L	L	H	L	2 <sup>2</sup>	4	2 <sup>9</sup>	512	2 <sup>17</sup>	131072	2 <sup>24</sup>	16777216
L	L	L	H	H	2 <sup>3</sup>	8	2 <sup>9</sup>	512	2 <sup>17</sup>	131072	2 <sup>24</sup>	16777216
L	L	H	L	L	2 <sup>4</sup>	16	2 <sup>9</sup>	512	2 <sup>17</sup>	131072	2 <sup>24</sup>	16777216
L	L	H	L	H	2 <sup>5</sup>	32	2 <sup>9</sup>	512	2 <sup>17</sup>	131072	2 <sup>24</sup>	16777216
L	L	H	H	L	2 <sup>6</sup>	64	2 <sup>9</sup>	512	2 <sup>17</sup>	131072	2 <sup>24</sup>	16777216
L	L	H	H	H	2 <sup>7</sup>	128	2 <sup>9</sup>	512	2 <sup>17</sup>	131072	2 <sup>24</sup>	16777216
L	H	L	L	L	2 <sup>8</sup>	256	2 <sup>9</sup>	512	2 <sup>17</sup>	131072	2 <sup>2</sup>	4
L	H	L	L	H	2 <sup>9</sup>	512	2 <sup>9</sup>	512	2 <sup>17</sup>	131072	2 <sup>2</sup>	4
L	H	L	H	L	2 <sup>10</sup>	1024	2 <sup>9</sup>	512	2 <sup>17</sup>	131072	2 <sup>4</sup>	16
L	H	L	H	H	2 <sup>11</sup>	2048	2 <sup>9</sup>	512	2 <sup>17</sup>	131072	2 <sup>4</sup>	16
L	H	H	L	L	2 <sup>12</sup>	4096	2 <sup>9</sup>	512	2 <sup>17</sup>	131072	2 <sup>6</sup>	64
L	H	H	L	H	2 <sup>13</sup>	8192	2 <sup>9</sup>	512	2 <sup>17</sup>	131072	2 <sup>6</sup>	64
L	H	H	H	L	2 <sup>14</sup>	16384	2 <sup>9</sup>	512	Disabled low	Disabled low	2 <sup>8</sup>	256
L	H	H	H	H	2 <sup>15</sup>	32768	2 <sup>9</sup>	512	Disabled low	Disabled low	2 <sup>8</sup>	256
H	L	L	L	L	2 <sup>16</sup>	65536	2 <sup>9</sup>	512	2 <sup>3</sup>	8	2 <sup>10</sup>	1024
H	L	L	L	H	2 <sup>17</sup>	131072	2 <sup>9</sup>	512	2 <sup>3</sup>	8	2 <sup>10</sup>	1024
H	L	L	H	L	2 <sup>18</sup>	262144	2 <sup>9</sup>	512	2 <sup>5</sup>	32	2 <sup>12</sup>	4096
H	L	L	H	H	2 <sup>19</sup>	524288	2 <sup>9</sup>	512	2 <sup>5</sup>	32	2 <sup>12</sup>	4096
H	L	H	L	L	2 <sup>20</sup>	1048576	2 <sup>9</sup>	512	2 <sup>7</sup>	128	2 <sup>14</sup>	16384
H	L	H	L	H	2 <sup>21</sup>	2097152	2 <sup>9</sup>	512	2 <sup>7</sup>	128	2 <sup>14</sup>	16384
H	L	H	H	L	2 <sup>22</sup>	4194304	Disabled low	Disabled low	2 <sup>9</sup>	512	2 <sup>16</sup>	65536
H	L	H	H	H	2 <sup>23</sup>	8388608	Disabled low	Disabled low	2 <sup>9</sup>	512	2 <sup>16</sup>	65536
H	H	L	L	L	2 <sup>24</sup>	16777216	2 <sup>3</sup>	8	2 <sup>11</sup>	2048	2 <sup>18</sup>	262144
H	H	L	L	H	2 <sup>25</sup>	33554432	2 <sup>3</sup>	8	2 <sup>11</sup>	2048	2 <sup>18</sup>	262144
H	H	L	H	L	2 <sup>26</sup>	67108864	2 <sup>5</sup>	32	2 <sup>13</sup>	8192	2 <sup>20</sup>	1048576
H	H	L	H	H	2 <sup>27</sup>	134217728	2 <sup>5</sup>	32	2 <sup>13</sup>	8192	2 <sup>20</sup>	1048576
H	H	H	L	L	2 <sup>28</sup>	268435456	2 <sup>7</sup>	128	2 <sup>15</sup>	32768	2 <sup>22</sup>	4194304
H	H	H	L	H	2 <sup>29</sup>	536870912	2 <sup>7</sup>	128	2 <sup>15</sup>	32768	2 <sup>22</sup>	4194304
H	H	H	H	L	2 <sup>30</sup>	1073741824	2 <sup>9</sup>	512	2 <sup>17</sup>	131072	2 <sup>24</sup>	16777216
H	H	H	H	H	2 <sup>31</sup>	2147483648	2 <sup>9</sup>	512	2 <sup>17</sup>	131072	2 <sup>24</sup>	16777216

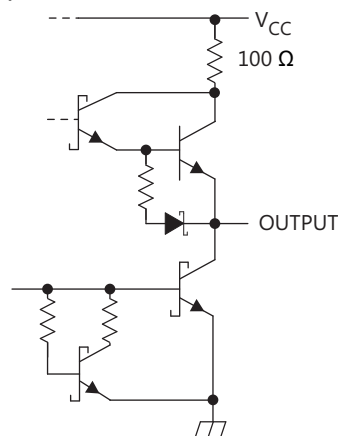
**Table 3. SN74LS294 Function Table**

PROGRAMMING INPUTS				FREQUENCY DIVISION			
				Q		TP	
D	C	B	A	BINARY	DECIMAL	BINARY	DECIMAL
L	L	L	L	Inhibit	Inhibit	Inhibit	Inhibit
L	L	L	H	Inhibit	Inhibit	Inhibit	Inhibit
L	L	H	L	2 <sup>2</sup>	4	2 <sup>9</sup>	512
L	L	H	H	2 <sup>3</sup>	8	2 <sup>9</sup>	512
L	H	L	L	2 <sup>4</sup>	16	2 <sup>9</sup>	512
L	H	L	H	2 <sup>5</sup>	32	2 <sup>9</sup>	512
L	H	H	L	2 <sup>6</sup>	64	2 <sup>9</sup>	512
L	H	H	H	2 <sup>7</sup>	128	Disabled Low	
H	L	L	L	2 <sup>8</sup>	256	2 <sup>2</sup>	4
H	L	L	H	2 <sup>9</sup>	512	2 <sup>3</sup>	8
H	L	H	L	2 <sup>10</sup>	1024	2 <sup>4</sup>	16
H	L	H	H	2 <sup>11</sup>	2048	2 <sup>5</sup>	32
H	H	L	L	2 <sup>12</sup>	4096	2 <sup>6</sup>	64
H	H	L	H	2 <sup>13</sup>	8192	2 <sup>7</sup>	128
H	H	H	L	2 <sup>14</sup>	16384	2 <sup>8</sup>	256
H	H	H	H	2 <sup>15</sup>	32768	2 <sup>9</sup>	512

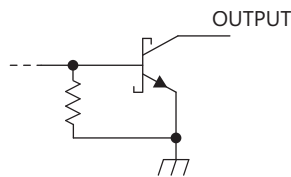
Figure 7, Figure 9, and Figure 9 show the schematics of inputs and outputs of the SN74LS292.



**Figure 7. Equivalent of Each Input**



**Figure 8. Typical of Q Outputs**



**Figure 9. Typical of TP Outputs**

## 9 Application and Implementation

### NOTE

Information in the following applications sections is not part of the TI component specification, and TI does not warrant its accuracy or completeness. TI's customers are responsible for determining suitability of components for their purposes. Customers should validate and test their design implementation to confirm system functionality.

### 9.1 Application Information

This device is used for configurable frequency, programmable frequency, and timing division as shown in [Typical Application](#).

### 9.2 Typical Application

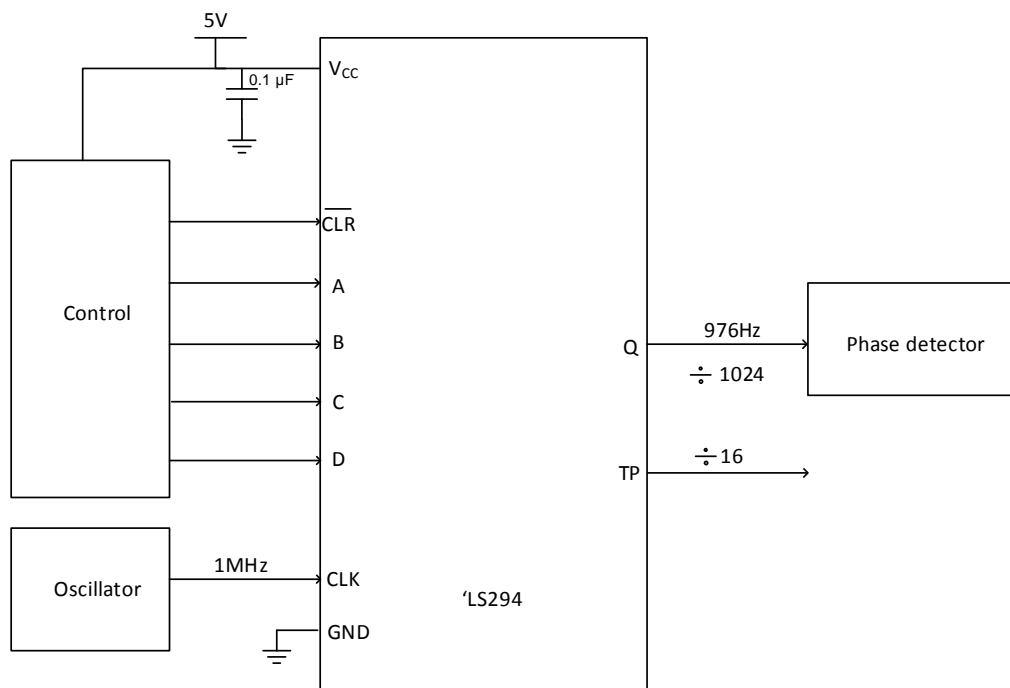


Figure 10. Typical application

#### 9.2.1 Design Requirements

This device does not have balanced output drive. Take care to avoid bus contention because it can sink currents that would exceed maximum limits. The high drive will also create fast edges into light loads so routing and load conditions should be considered to prevent ringing.

#### 9.2.2 Detailed Design Procedure

- Recommended Input Conditions:
  - Rise time and fall time specs. See  $(\Delta t/\Delta V)$  in [Recommended Operating Conditions](#).
  - Specified high and low levels. See  $(V_{IH}$  and  $V_{IL})$  in [Recommended Operating Conditions](#).
  - Inputs can go as high as  $(V_I \text{ max})$  in [Recommended Operating Conditions](#) at any valid  $V_{CC}$ .
- Recommended Output Conditions:
  - Load currents should not exceed  $(I_{OH}, I_{OL})$  per output. These limits are located in the [Recommended Operating Conditions](#).

## Typical Application (continued)

### 9.2.3 Application Curve

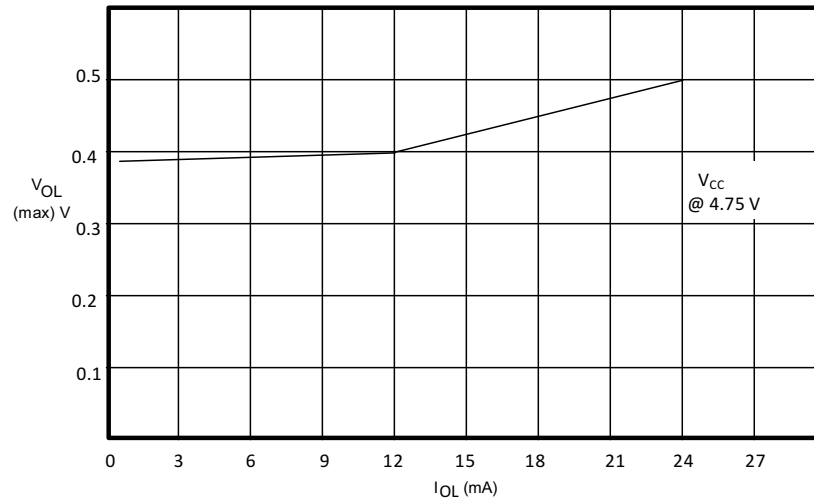


Figure 11.  $V_{OL}$  vs  $I_{OL}$

## 10 Power Supply Recommendations

The power supply can be any voltage between the minimum and maximum supply voltage rating located in [Recommended Operating Conditions](#).

Each  $V_{CC}$  pin should have a good bypass capacitor to prevent power disturbance. For devices with a single supply, a 0.1- $\mu$ F capacitor is recommended and, if there are multiple  $V_{CC}$  pins, then a 0.01- $\mu$ F or 0.022- $\mu$ F capacitor is recommended for each power pin. It is acceptable to parallel multiple bypass capacitors to reject different frequencies of noise. 0.1- $\mu$ F and 1- $\mu$ F capacitors are commonly used in parallel. The bypass capacitor should be installed as close to the power pin as possible for best results.

## 11 Layout

### 11.1 Layout Guidelines

When using multiple bit logic devices, inputs should not ever float. In many cases, functions or parts of functions of digital logic devices are unused (for example, when only two inputs of a triple-input AND gate are used or only 3 of the 4 buffer gates are used). Such input pins should not be left unconnected because the undefined voltages at the outside connections result in undefined operational states.

The following are the rules that must be observed under all circumstances:

- All unused inputs of digital logic devices must be connected to a high or low bias to prevent them from floating.
- The logic level that must be applied to any particular unused input depends on the function of the device. Generally they are tied to GND or  $V_{CC}$ , whichever make more sense or is more convenient.

### 11.2 Layout Example

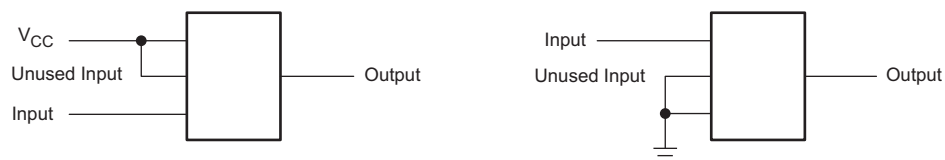


Figure 12. Generic Layout Best Practices

## 12 Device and Documentation Support

### 12.1 Documentation Support

#### 12.1.1 Related Documentation

For related documentation, see the following:

- *Digital Phase-Locked Loop Design Using SN74LS297*, [SDLA005](#)
- *Introduction to Logic*, [SLVA700](#)

### 12.2 Related Links

The table below lists quick access links. Categories include technical documents, support and community resources, tools and software, and quick access to sample or buy.

**Table 4. Related Links**

PARTS	PRODUCT FOLDER	SAMPLE & BUY	TECHNICAL DOCUMENTS	TOOLS & SOFTWARE	SUPPORT & COMMUNITY
SN74LS292	<a href="#">Click here</a>	<a href="#">Click here</a>	<a href="#">Click here</a>	<a href="#">Click here</a>	<a href="#">Click here</a>
SN74LS294	<a href="#">Click here</a>	<a href="#">Click here</a>	<a href="#">Click here</a>	<a href="#">Click here</a>	<a href="#">Click here</a>

### 12.3 Community Resources

The following links connect to TI community resources. Linked contents are provided "AS IS" by the respective contributors. They do not constitute TI specifications and do not necessarily reflect TI's views; see TI's [Terms of Use](#).

**TI E2E™ Online Community** *TI's Engineer-to-Engineer (E2E) Community*. Created to foster collaboration among engineers. At [e2e.ti.com](http://e2e.ti.com), you can ask questions, share knowledge, explore ideas and help solve problems with fellow engineers.

**Design Support** *TI's Design Support* Quickly find helpful E2E forums along with design support tools and contact information for technical support.

### 12.4 Trademarks

E2E is a trademark of Texas Instruments.  
All other trademarks are the property of their respective owners.

### 12.5 Electrostatic Discharge Caution



These devices have limited built-in ESD protection. The leads should be shorted together or the device placed in conductive foam during storage or handling to prevent electrostatic damage to the MOS gates.

### 12.6 Glossary

[SLYZ022](#) — *TI Glossary*.

This glossary lists and explains terms, acronyms, and definitions.

## 13 Mechanical, Packaging, and Orderable Information

The following pages include mechanical, packaging, and orderable information. This information is the most current data available for the designated devices. This data is subject to change without notice and revision of this document. For browser-based versions of this data sheet, refer to the left-hand navigation.

**PACKAGING INFORMATION**

Orderable Device	Status (1)	Package Type	Package Drawing	Pins	Package Qty	Eco Plan (2)	Lead/Ball Finish (6)	MSL Peak Temp (3)	Op Temp (°C)	Device Marking (4/5)	Samples
SN74LS292N	ACTIVE	PDIP	N	16	25	Pb-Free (RoHS)	CU NIPDAU	N / A for Pkg Type	0 to 70	SN74LS292N	<a href="#">Samples</a>
SN74LS294N	ACTIVE	PDIP	N	16	25	Pb-Free (RoHS)	CU NIPDAU	N / A for Pkg Type	0 to 70	SN74LS294N	<a href="#">Samples</a>

(1) The marketing status values are defined as follows:

**ACTIVE:** Product device recommended for new designs.

**LIFEBUY:** TI has announced that the device will be discontinued, and a lifetime-buy period is in effect.

**NRND:** Not recommended for new designs. Device is in production to support existing customers, but TI does not recommend using this part in a new design.

**PREVIEW:** Device has been announced but is not in production. Samples may or may not be available.

**OBSOLETE:** TI has discontinued the production of the device.

(2) Eco Plan - The planned eco-friendly classification: Pb-Free (RoHS), Pb-Free (RoHS Exempt), or Green (RoHS & no Sb/Br) - please check <http://www.ti.com/productcontent> for the latest availability information and additional product content details.

**TBD:** The Pb-Free/Green conversion plan has not been defined.

**Pb-Free (RoHS):** TI's terms "Lead-Free" or "Pb-Free" mean semiconductor products that are compatible with the current RoHS requirements for all 6 substances, including the requirement that lead not exceed 0.1% by weight in homogeneous materials. Where designed to be soldered at high temperatures, TI Pb-Free products are suitable for use in specified lead-free processes.

**Pb-Free (RoHS Exempt):** This component has a RoHS exemption for either 1) lead-based flip-chip solder bumps used between the die and package, or 2) lead-based die adhesive used between the die and leadframe. The component is otherwise considered Pb-Free (RoHS compatible) as defined above.

**Green (RoHS & no Sb/Br):** TI defines "Green" to mean Pb-Free (RoHS compatible), and free of Bromine (Br) and Antimony (Sb) based flame retardants (Br or Sb do not exceed 0.1% by weight in homogeneous material)

(3) MSL, Peak Temp. - The Moisture Sensitivity Level rating according to the JEDEC industry standard classifications, and peak solder temperature.

(4) There may be additional marking, which relates to the logo, the lot trace code information, or the environmental category on the device.

(5) Multiple Device Markings will be inside parentheses. Only one Device Marking contained in parentheses and separated by a "~" will appear on a device. If a line is indented then it is a continuation of the previous line and the two combined represent the entire Device Marking for that device.

(6) Lead/Ball Finish - Orderable Devices may have multiple material finish options. Finish options are separated by a vertical ruled line. Lead/Ball Finish values may wrap to two lines if the finish value exceeds the maximum column width.

**Important Information and Disclaimer:** The information provided on this page represents TI's knowledge and belief as of the date that it is provided. TI bases its knowledge and belief on information provided by third parties, and makes no representation or warranty as to the accuracy of such information. Efforts are underway to better integrate information from third parties. TI has taken and continues to take reasonable steps to provide representative and accurate information but may not have conducted destructive testing or chemical analysis on incoming materials and chemicals. TI and TI suppliers consider certain information to be proprietary, and thus CAS numbers and other limited information may not be available for release.

In no event shall TI's liability arising out of such information exceed the total purchase price of the TI part(s) at issue in this document sold by TI to Customer on an annual basis.

N (R-PDIP-T\*\*)

PLASTIC DUAL-IN-LINE PACKAGE

16 PINS SHOWN



- NOTES:
- A. All linear dimensions are in inches (millimeters).
  - B. This drawing is subject to change without notice.
  - $\triangle C$  Falls within JEDEC MS-001, except 18 and 20 pin minimum body length (Dim A).
  - $\triangle D$  The 20 pin end lead shoulder width is a vendor option, either half or full width.

## IMPORTANT NOTICE AND DISCLAIMER

TI PROVIDES TECHNICAL AND RELIABILITY DATA (INCLUDING DATASHEETS), DESIGN RESOURCES (INCLUDING REFERENCE DESIGNS), APPLICATION OR OTHER DESIGN ADVICE, WEB TOOLS, SAFETY INFORMATION, AND OTHER RESOURCES "AS IS" AND WITH ALL FAULTS, AND DISCLAIMS ALL WARRANTIES, EXPRESS AND IMPLIED, INCLUDING WITHOUT LIMITATION ANY IMPLIED WARRANTIES OF MERCHANTABILITY, FITNESS FOR A PARTICULAR PURPOSE OR NON-INFRINGEMENT OF THIRD PARTY INTELLECTUAL PROPERTY RIGHTS.

These resources are intended for skilled developers designing with TI products. You are solely responsible for (1) selecting the appropriate TI products for your application, (2) designing, validating and testing your application, and (3) ensuring your application meets applicable standards, and any other safety, security, or other requirements. These resources are subject to change without notice. TI grants you permission to use these resources only for development of an application that uses the TI products described in the resource. Other reproduction and display of these resources is prohibited. No license is granted to any other TI intellectual property right or to any third party intellectual property right. TI disclaims responsibility for, and you will fully indemnify TI and its representatives against, any claims, damages, costs, losses, and liabilities arising out of your use of these resources.

TI's products are provided subject to TI's Terms of Sale ([www.ti.com/legal/termsofsale.html](http://www.ti.com/legal/termsofsale.html)) or other applicable terms available either on [ti.com](http://ti.com) or provided in conjunction with such TI products. TI's provision of these resources does not expand or otherwise alter TI's applicable warranties or warranty disclaimers for TI products.

Mailing Address: Texas Instruments, Post Office Box 655303, Dallas, Texas 75265  
Copyright © 2019, Texas Instruments Incorporated

## Looking for pricing, stock, or lifecycle information?

Click below to explore more details on WIN SOURCE:

 [View SN74LS294N on WIN SOURCE](#)

 [Texas Instruments](#) Information

## Optimize Your Supply Chain with WIN SOURCE Solutions

-  Global Sourcing Solution
-  Obsolete Management
-  Cost Control Management
-  Shortage Management
-  Alternative Solution
-  Excess Inventory Management