



**THE DATASHEET OF
TMC57253DSB**



- **TTL-Compatible Inputs**
- **CCD-Compatible Outputs**
- **Adjustable Clock Levels**
- **High-Speed Clear**
- **Serial-Gate Midlevel for CDS Operation**
- **Solid-State Reliability**

description

The TMC57253 is a monolithic CMOS integrated circuit designed to drive image-area gates (IAG1, IAG2), antiblooming gate (ABG), storage-area gate (SAG), and serial-register gate (SRG) of the Texas Instruments (TI™) TC255 CCD image sensor. The TMC57253 interfaces the CCD image sensor to the TI TMC57751 ASIC or user-defined timing generator; it receives TTL-input signals from the timing generator and outputs level-shifted signals to the image sensor.

ABOUT follows ABIN and ABMIN and switches between V_{ABL} , V_{AB} , and V_{ABM} . IA1OUT and IA2OUT follow IA1IN and IA2IN, respectively, and switch between GND and V_{IA} . The SAOUT output follows the SAIN and switches GND and V_S . SROUT follows SRIN and SRMIN and switches between GND, V_{SM} , and V_S .

The TMC57253 is available in a 24-pin HSOP-B surface-mount package and is characterized for operation from -20°C to 45°C .

HSOP TYPE-B
(TOP VIEW)

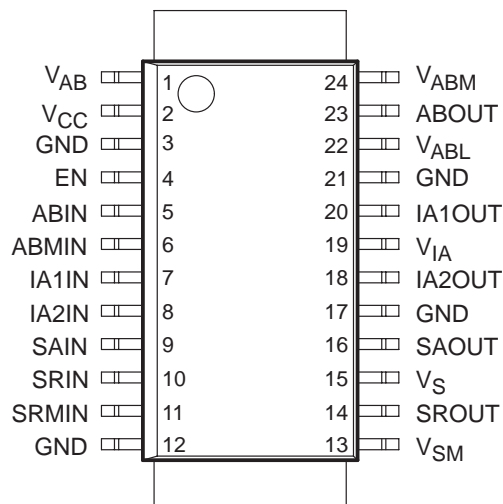

logic symbol

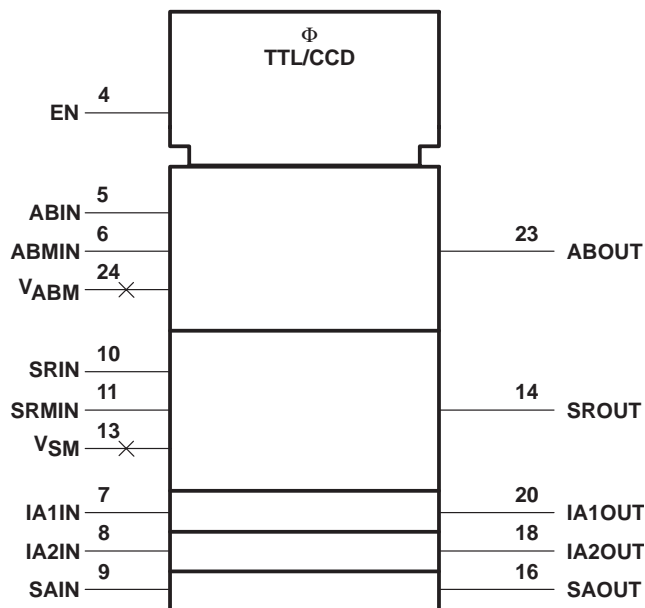

This device contains circuits to protect its inputs and outputs against damage due to high static voltages or electrostatic fields. These circuits have been qualified to protect this device against electrostatic discharges (ESD) of up to 2 kV according to MIL-STD-883C, Method 3015; however, it is advised that precautions be taken to avoid application of any voltage higher than maximum-rated voltages to these high-impedance circuits. During storage or handling, the device leads should be shorted together or the device should be placed in conductive foam. In a circuit, unused inputs should always be connected to an appropriated logic voltage level, preferably either V_{CC} or ground. Specific guidelines for handling devices of this type are contained in the publication *Guidelines for Handling Electrostatic-Discharge-Sensitive (ESDS) Devices and Assemblies* available from Texas Instruments.

TI is a trademark of Texas Instruments Incorporated.

PRODUCTION DATA information is current as of publication date. Products conform to specifications per the terms of Texas Instruments standard warranty. Production processing does not necessarily include testing of all parameters.

 **TEXAS
INSTRUMENTS**

POST OFFICE BOX 655303 • DALLAS, TEXAS 75265

Copyright © 1994, Texas Instruments Incorporated

TMC57253 DRIVER

SOCS040A – MARCH 1994 – REVISED NOVEMBER 1994

Terminal Functions

TERMINAL		I/O	DESCRIPTION
NAME	NO.		
ABIN	5	I	Antiblooming input
ABMIN	6	I	Antiblooming midlevel input
ABOUT	23	O	Antiblooming output
EN	4	I	Enable control input
GND	3, 12, 17, 21		Ground
IA1IN	7	I	Image area 1 input
IA1OUT	20	O	Image area 1 output
IA2IN	8	I	Image area 2 input
IA2OUT	18	O	Image area 2 output
SAIN	9	I	Storage area input
SAOUT	16	O	Storage area output
SRIN	10	I	Serial register input
SRMIN	11	I	Serial register mid input
SROUT	14	O	Serial register output
V _{AB}	1		High-level antiblooming supply voltage
V _{ABL}	22		Low-level antiblooming supply voltage
V _{ABM}	24		Midlevel antiblooming supply voltage
V _{CC}	2		Supply voltage
V _{IA}	19		Image supply voltage
V _S	15		Serial and storage-gate supply voltage
V _{SM}	13		Midlevel serial-gate supply voltage

functional block diagram

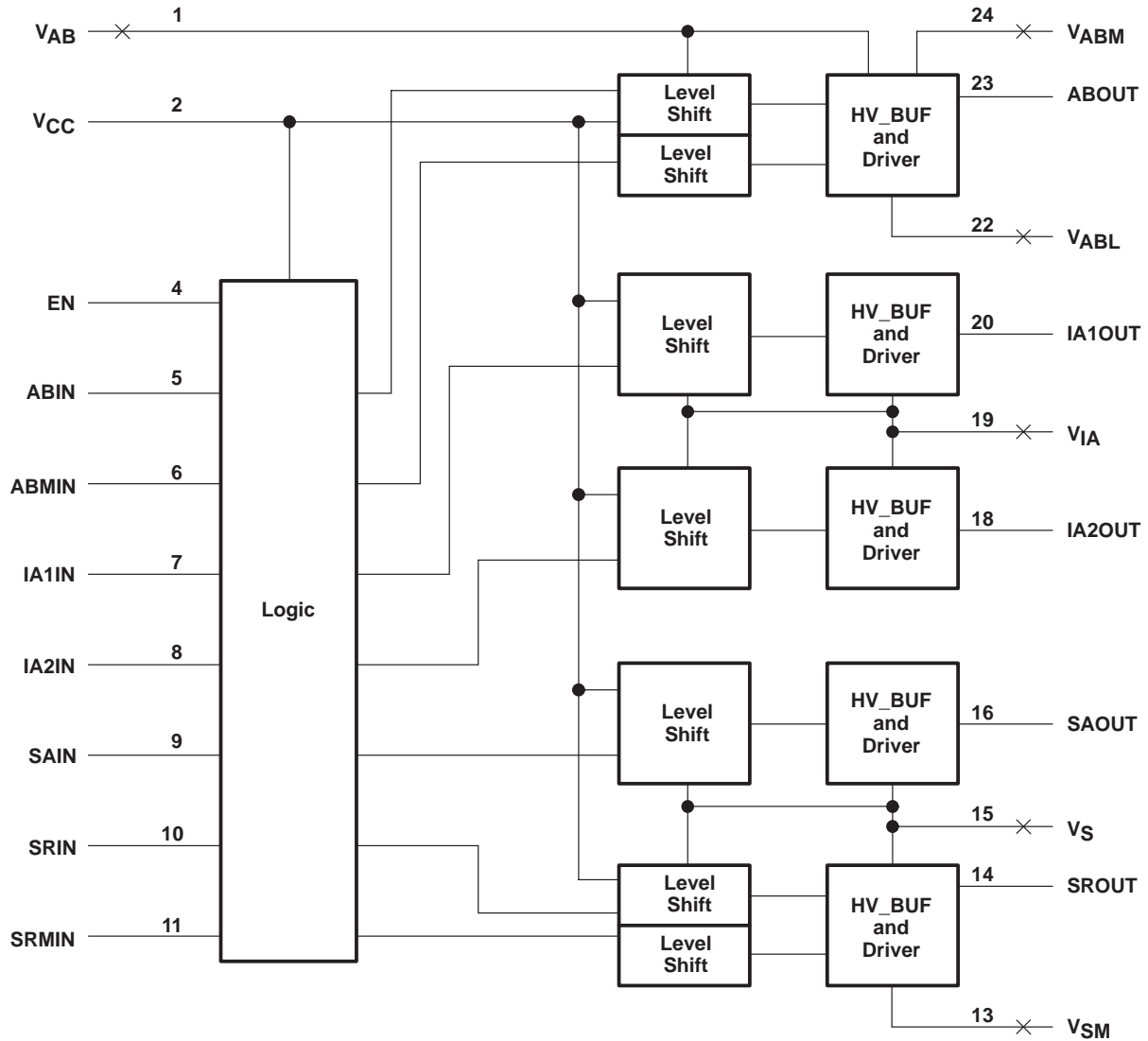

TMC57253 DRIVER

SOCS040A – MARCH 1994 – REVISED NOVEMBER 1994

absolute maximum ratings over operating free-air temperature range (unless otherwise noted)†

Supply voltage range, V_{CC} (see Note 1)	0 V to 20 V
Continuous total power dissipation at (or below) $T_A = 25^\circ\text{C}$:	
Unmounted device (see Figure 1)	1990 mW
Mounted device (see Figure 1)	2754 mW
Operating free-air temperature range, T_A	-20°C to 45°C
Storage temperature range, T_{STG}	-55°C to 125°C
Lead temperature: 1,6 mm (1/16 inch) from case for 10 seconds	260°C
1,6 mm (1/16 inch) from case for 3 seconds	350°C

† Stresses beyond those listed under “absolute maximum ratings” may cause permanent damage to the device. These are stress ratings only, and functional operation of the device at these or any other conditions beyond those indicated under “recommended operating conditions” is not implied. Exposure to absolute-maximum-rated conditions for extended periods may affect device reliability.

NOTE 1: All voltages are with respect to GND.

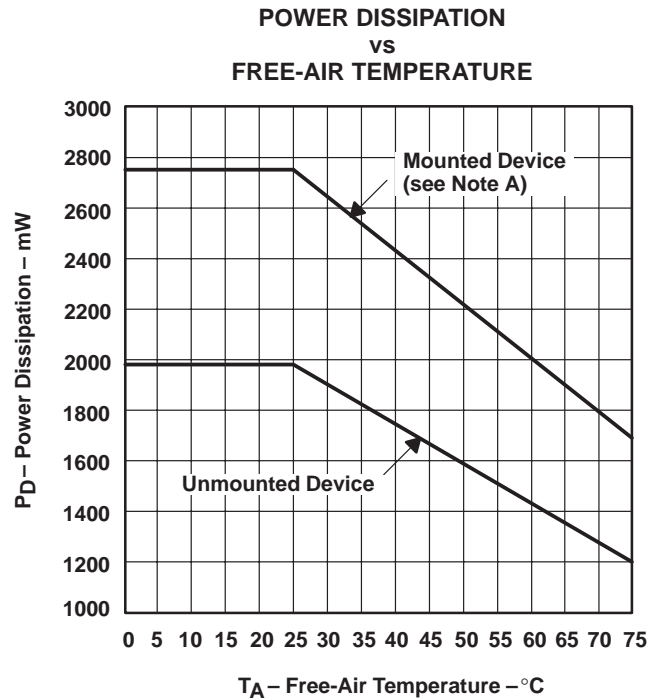

NOTE A: The mounted-device derating curve of Figure 1 is obtained under the following conditions:
 The board is 50 mm by 50 mm by 1.6 mm thick.
 The board material is glass epoxy.
 The copper thickness of all the etch runs is 35 microns.
 Etch-run dimensions – All twenty etch runs are 0.4 mm by 22 mm.
 Each chip is soldered to the board.
 An aluminum cooling fin 10 mm by 10 mm by 1 mm thick is coupled to the chip with thermal paste.

Figure 1

recommended operating conditions

		MIN	NOM	MAX	UNIT
Supply voltage, V_{CC}		4.5	5	5.5	V
Antiblooming supply voltage, V_{AB}		8		18	V
Low-level antiblooming supply voltage, V_{ABL}		0		3	V
Midlevel antiblooming supply voltage, V_{ABM}		3		10	V
Image-gate supply voltage, V_{IA}		8		14	V
Serial and storage-gate supply voltage, V_S		8		14	V
Serial-gate midlevel supply voltage, V_{SM}		3		7	V
High-level input voltage, V_{IH}		2.5			V
Low-level input voltage, V_{IL}				0.9	V
Frequency, f_{clock}	IA1OUT, IA2OUT (fast clear)			25	MHz
	IA1OUT, IA2OUT (transfer)			12.5	MHz
	SAOUT (transfer)			12.5	MHz
	ABOUT			12.5	MHz
	SROUT			12.5	MHz
Drive mode (on ratio)	IA1OUT, IA2OUT, SAOUT		1%		
	ABOUT		23%		
	SROUT		85%		
Operating free-air temperature, T_A		-20		45	°C

electrical characteristics over recommended ranges of supply voltage and operating free-air temperature (unless otherwise noted)

PARAMETER		TEST CONDITIONS		MIN	TYP	MAX	UNIT
V_{OH}	High-level output voltage	$I_{OH} = 0.5 \text{ mA}$			12		V
V_{OL}	Low-level output voltage	$I_{OL} = 0$			0		V
I_{IH}	High-level input current	$V_{IH} = 5 \text{ V}$				± 10	μA
I_{IL}	Low-level input current	$V_{IL} = 0$				± 10	μA
I_{CC}	Supply current	$V_{CC} = 5 \text{ V}$			0.1		mA
I_{IA}	Image-gate supply current	$V_{IA} = 12 \text{ V}$			5		mA
I_{AB}	Antiblooming supply current	$V_{AB} = 12 \text{ V}$			15		mA
I_{ABL}	Low-level antiblooming supply current				15		mA
I_{ABM}	Midlevel antiblooming supply current				0.5		mA
I_{SM}	Midlevel serial-gate supply current	$V_S = 12 \text{ V}$			2		mA
I_S	Serial-gate supply current				2		mA
r_o	Output resistance	IA1OUT, IA2OUT, SAOUT	$I_O = 10 \text{ mA}$, $V_I = V_{CC}$, GND	$V_{IA} = 8 \text{ V}$		5	Ω
		ABOUT	$I_O = 10 \text{ mA}$, $V_{SM} = 4 \text{ V}$, $V_I = V_{CC}$, GND	$V_{AB} = 8 \text{ V}$, $V_{ABM} = 4 \text{ V}$, $V_{ABL} = 0 \text{ V}$		10	
		SROUT	$I_O = 10 \text{ mA}$, $V_{SM} = 4 \text{ V}$,	$V_S = 8 \text{ V}$, $V_I = V_{CC}$, GND		50	

TMC57253 DRIVER

SOCS040A – MARCH 1994 – REVISED NOVEMBER 1994

switching characteristics for ABOUT, IA1OUT, IA2OUT, SAOUT, and SROUT, $V_{AB} = 13\text{ V}$, $V_{ABI} = 1.5\text{ V}$, $V_{ABM} = 6.5\text{ V}$, $V_{IA} = 11\text{ V}$, $V_{SM} = 5\text{ V}$, $V_S = 11\text{ V}$, $T_A = 25^\circ\text{C}$ (unless otherwise noted)†

PARAMETER	FROM (INPUT)	TO (OUTPUT)	TEST CONDITIONS	MIN	MAX	UNIT
t_{pd} Propagation delay time	IA1IN	IA1OUT	See Figure 3		85	ns
	IA2IN	IA2OUT				
	SAIN	SAOUT				
	SRIN	SROUT	See Figure 4	40	80	
	SRMIN					
	ABIN	ABOUT	See Figure 5		90	
	ABMIN					
t_{PLZ} Disable time	EN	IA1OUT	See Figure 6		1	ns
		IA2OUT				
		SAOUT				
		SROUT				
		ABOUT				
t_{PZH} Enable time	EN	IA1OUT	See Figure 6		1	ns
		IA2OUT				
		SAOUT				
		SROUT				
		ABOUT				
Duty cycle‡	IA1OUT		See Figure 3, $t_c = 80\text{ ns}$	40%	60%	
	IA2OUT					
	SAOUT					
	ABOUT		See Figure 3, $t_c = 160\text{ ns}$	40%	60%	

† The load is a Texas Instruments TC255 CCD image sensor.

‡
$$\text{Duty cycle} = \frac{t_{WH}}{(t_{WH} + t_{WL})} \times 100$$

PARAMETER MEASUREMENT INFORMATION

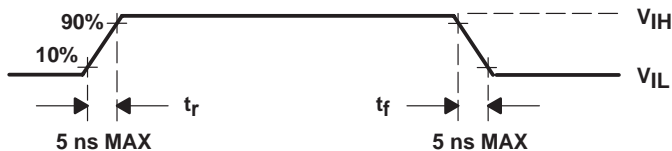
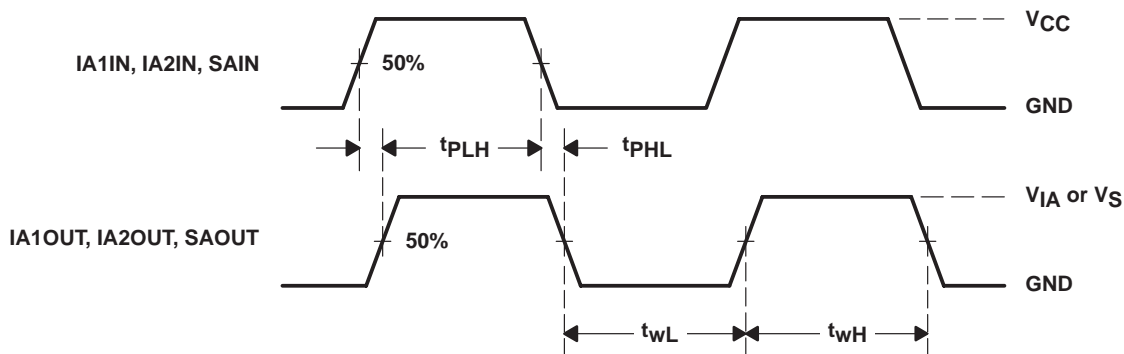
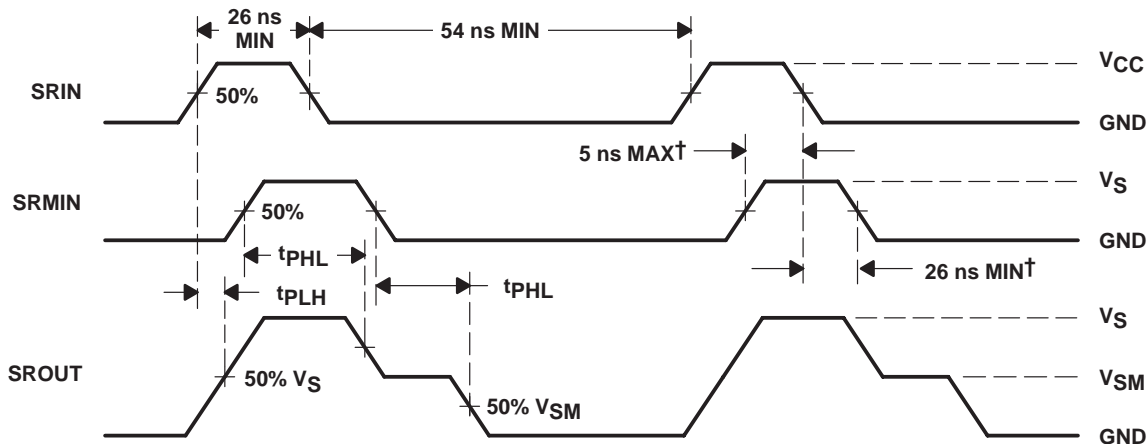

Figure 2. Rise and Fall Time Requirements for Input Signals



NOTE A: $t_{pd} = t_{PLH}$ or t_{PHL}

Figure 3. Duty Cycle and Propagation Delay



† If SRIN and SRMIN are both high, SROUT follows SRIN.

NOTE A: $t_{pd} = t_{PLH}$ or t_{PHL}

Figure 4. Serial-Register-Driver Waveforms

PARAMETER MEASUREMENT INFORMATION

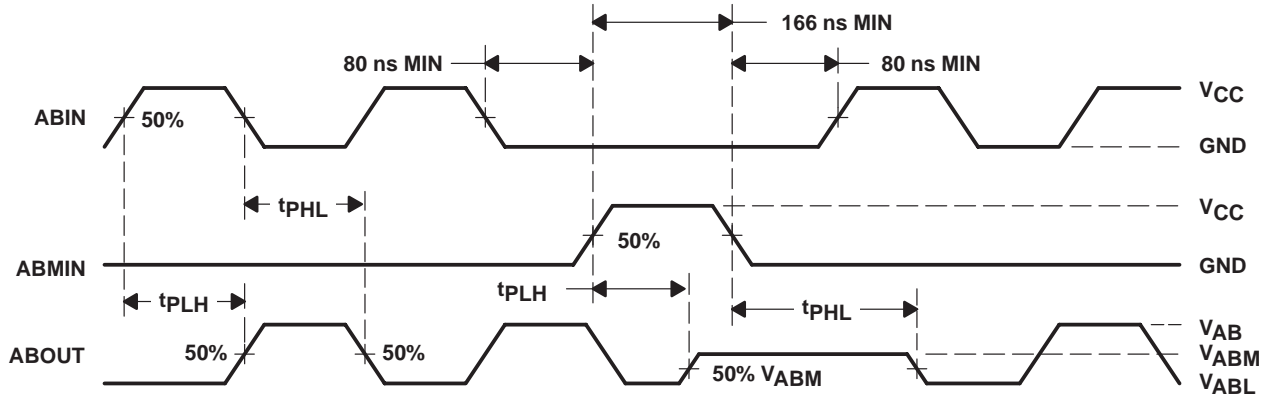

- NOTES: A. V_{AB} and V_{ABM} are in a short-circuit condition if ABIN and ABMIN are held high at the same time. This short-circuit condition can destroy the device.
B. $t_{pd} = t_{PLH}$ or t_{PHL}

Figure 5. Antiblooming-Driver Waveforms

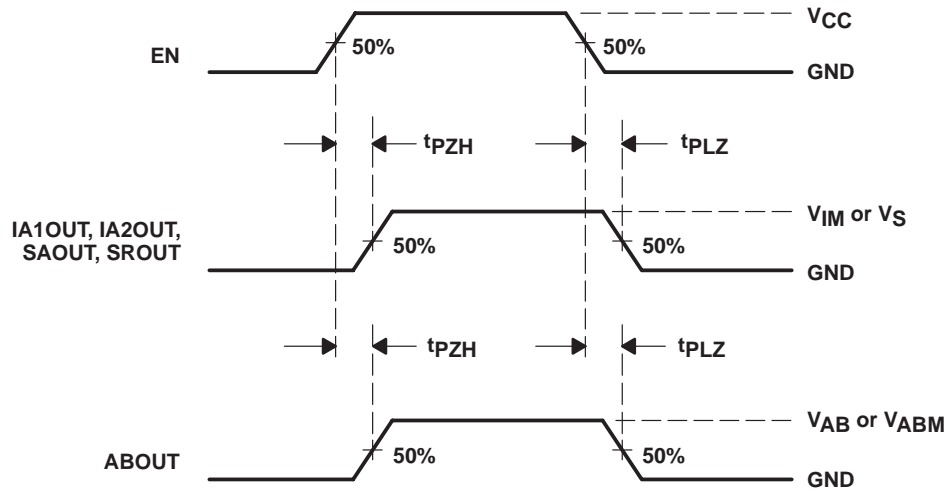
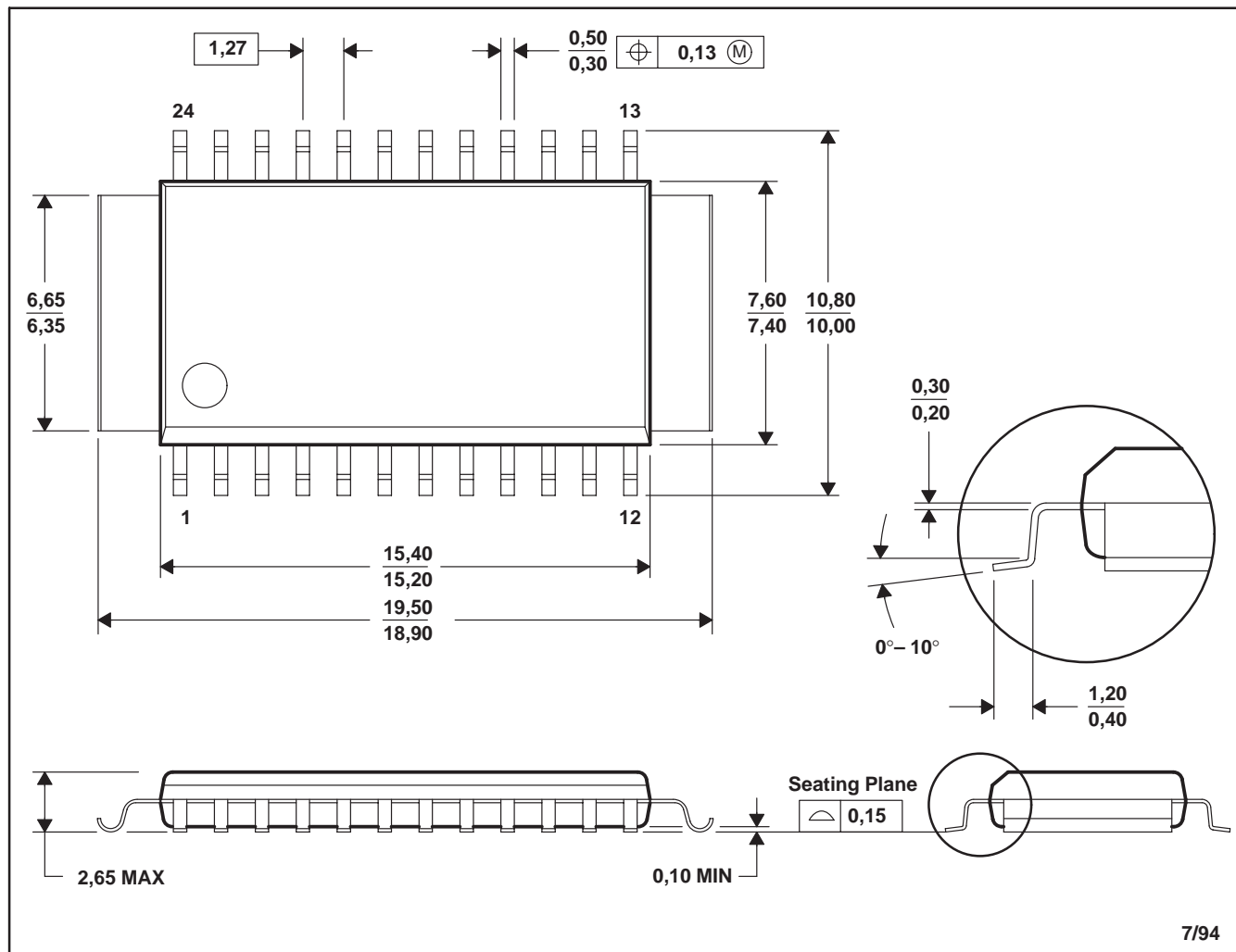

Figure 6. Enable Waveforms

MECHANICAL DATA

HSOP-B plastic small-outline package

This small-outline package consists of a circuit mounted on a lead frame and encapsulated within a plastic compound. The compound will withstand soldering temperature with no deformation, and circuit performance characteristics will remain stable when operated in high-humidity conditions. Leads require no additional cleaning or processing when used in soldered assembly.



- NOTES: A. All linear dimensions are in millimeters.
 B. This drawing is subject to change without notice.
 C. Body dimensions do not include mold flash or protrusion.

MECHANICAL DATA

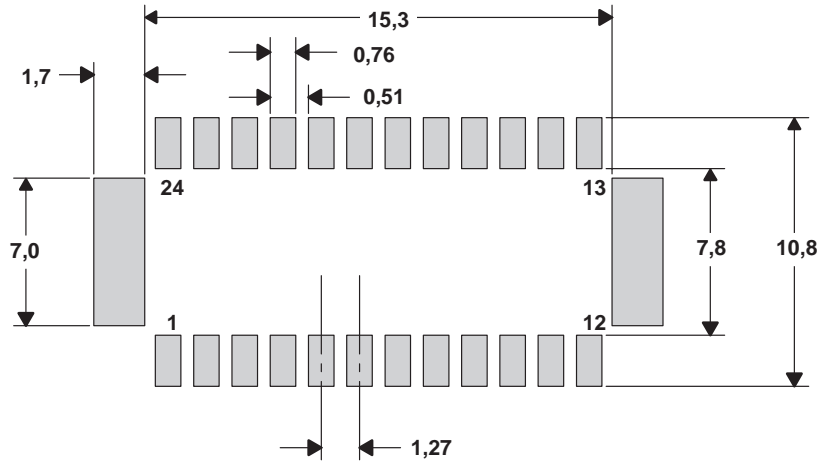

ALL LINEAR DIMENSIONS ARE IN MILLIMETERS

Figure 7. 24-Pin/375-mil HSOP Land Design

IMPORTANT NOTICE

Texas Instruments and its subsidiaries (TI) reserve the right to make changes to their products or to discontinue any product or service without notice, and advise customers to obtain the latest version of relevant information to verify, before placing orders, that information being relied on is current and complete. All products are sold subject to the terms and conditions of sale supplied at the time of order acknowledgement, including those pertaining to warranty, patent infringement, and limitation of liability.

TI warrants performance of its semiconductor products to the specifications applicable at the time of sale in accordance with TI's standard warranty. Testing and other quality control techniques are utilized to the extent TI deems necessary to support this warranty. Specific testing of all parameters of each device is not necessarily performed, except those mandated by government requirements.

CERTAIN APPLICATIONS USING SEMICONDUCTOR PRODUCTS MAY INVOLVE POTENTIAL RISKS OF DEATH, PERSONAL INJURY, OR SEVERE PROPERTY OR ENVIRONMENTAL DAMAGE ("CRITICAL APPLICATIONS"). TI SEMICONDUCTOR PRODUCTS ARE NOT DESIGNED, AUTHORIZED, OR WARRANTED TO BE SUITABLE FOR USE IN LIFE-SUPPORT DEVICES OR SYSTEMS OR OTHER CRITICAL APPLICATIONS. INCLUSION OF TI PRODUCTS IN SUCH APPLICATIONS IS UNDERSTOOD TO BE FULLY AT THE CUSTOMER'S RISK.

In order to minimize risks associated with the customer's applications, adequate design and operating safeguards must be provided by the customer to minimize inherent or procedural hazards.

TI assumes no liability for applications assistance or customer product design. TI does not warrant or represent that any license, either express or implied, is granted under any patent right, copyright, mask work right, or other intellectual property right of TI covering or relating to any combination, machine, or process in which such semiconductor products or services might be or are used. TI's publication of information regarding any third party's products or services does not constitute TI's approval, warranty or endorsement thereof.

Looking for pricing, stock, or lifecycle information?

Click below to explore more details on WIN SOURCE:

 [View TMC57253DSB](#) on WIN SOURCE

 [Texas Instruments](#) Information

Optimize Your Supply Chain with WIN SOURCE Solutions

-  Global Sourcing Solution
-  Obsolete Management
-  Cost Control Management
-  Shortage Management
-  Alternative Solution
-  Excess Inventory Management