



**THE DATASHEET OF
VNL5090N3TR-E**



OMNIFET III fully protected low side driver for automotive applications

Datasheet - production data

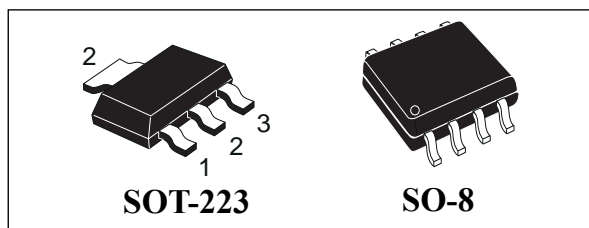

Description

The VNL5090N3-E and VNL5090S5-E are monolithic devices made using STMicroelectronics® VIPOWER® technology, intended for driving resistive or inductive loads with one side connected to the battery. Built-in thermal shutdown protects the chip from overtemperature and short-circuit.

Output current limitation protects the devices in an overload condition. In case of long duration overload, the device limits the dissipated power to a safe level up to thermal shutdown intervention. Thermal shutdown, with automatic restart, allows the devices to recover normal operation as soon as a fault condition disappears. Fast demagnetization of inductive loads is achieved at turn-off.

Features

Type	V _{clamp}	R _{DS(on)}	I _D
VNL5090N3-E	41 V	90 mΩ	13 A
VNL5090S5-E			

- AEC-Q100 qualified
- Drain current: 13 A
- ESD protection
- Overvoltage clamp
- Thermal shutdown
- Current and power limitation
- Very low standby current
- Very low electromagnetic susceptibility
- Compliant with European directive 2002/95/EC
- Open drain status output (VNL5090S5-E only)
- Specially intended for 2 x R10W or 4 x R5W automotive signal lamps



Table 1. Devices summary

Package	Order codes	
	Tube	Tape and reel
SOT-223	VNL5090N3-E	VNL5090N3TR-E
SO-8	VNL5090S5-E	VNL5090S5TR-E

Contents

- 1 Block diagrams and pins configurations 5**

- 2 Electrical specifications 8**
 - 2.1 Absolute maximum ratings 8
 - 2.2 Thermal data 8
 - 2.3 Electrical characteristics 9

- 3 Application information 13**
 - 3.1 MCU I/O protection 14

- 4 Package and PC board thermal data 16**
 - 4.1 SOT-223 thermal data 16
 - 4.2 SO-8 thermal data 19

- 5 Package and packing information 22**
 - 5.1 SOT-223 mechanical data 22
 - 5.2 SO-8 mechanical data 23
 - 5.3 SOT-223 packing information 25
 - 5.4 SO-8 packing information 26

- 6 Revision history 27**

List of tables

Table 1.	Devices summary	1
Table 2.	Pin function	6
Table 3.	Suggested connections for unused and N.C. pins	7
Table 4.	Absolute maximum ratings	8
Table 5.	Thermal data	8
Table 6.	PowerMOS section	9
Table 7.	Source drain diode	9
Table 8.	Input section (VNL5090N3-E only)	9
Table 9.	Status pin (VNL5090S5-E only)	9
Table 10.	Logic input (VNL5090S5-E only)	10
Table 11.	Openload detection (VNL5090S5-E only)	10
Table 12.	Supply section (VNL5090S5-E only)	10
Table 13.	Switching characteristics	11
Table 14.	Protection and diagnostics	11
Table 15.	Truth table (VNL5090S5-E only)	12
Table 16.	SOT-223 thermal parameters	18
Table 17.	SO-8 thermal parameters	21
Table 18.	SOT-223 mechanical data	23
Table 19.	SO-8 mechanical data	24
Table 20.	Document revision history	27

List of figures

Figure 1.	VNL5090N3-E block diagram	5
Figure 2.	VNL5090S5-E block diagram	5
Figure 3.	VNL5090N3-E current and voltage conventions.	6
Figure 4.	VNL5090S5-E current and voltage conventions	6
Figure 5.	Configuration diagrams (top view)	7
Figure 6.	Switching characteristics.	12
Figure 7.	VNL5090N3-E application schematic	13
Figure 8.	VNL5090S5-E application schematic	13
Figure 9.	Maximum demagnetization energy ($V_{CC} = 16\text{ V}$)	15
Figure 10.	SOT-223 PC board	16
Figure 11.	SOT-223 $R_{thj-amb}$ vs PCB copper area in open box free air condition	16
Figure 12.	SOT-223 thermal impedance junction ambient single pulse.	17
Figure 13.	Thermal fitting model of a LSD in SOT-223	17
Figure 14.	SO-8 PC board	19
Figure 15.	SO-8 $R_{thj-amb}$ vs PCB copper area in open box free air condition	19
Figure 16.	SO-8 thermal impedance junction ambient single pulse.	20
Figure 17.	Thermal fitting model of a LSD in SO-8	20
Figure 18.	SOT-223 package dimensions	22
Figure 19.	SO-8 package dimensions	23
Figure 20.	SOT-223 tape and reel shipment (suffix "TR")	25
Figure 21.	SO-8 tube shipment (no suffix)	26
Figure 22.	SO-8 tape and reel shipment (suffix "TR")	26

1 Block diagrams and pins configurations

Figure 1. VNL5090N3-E block diagram

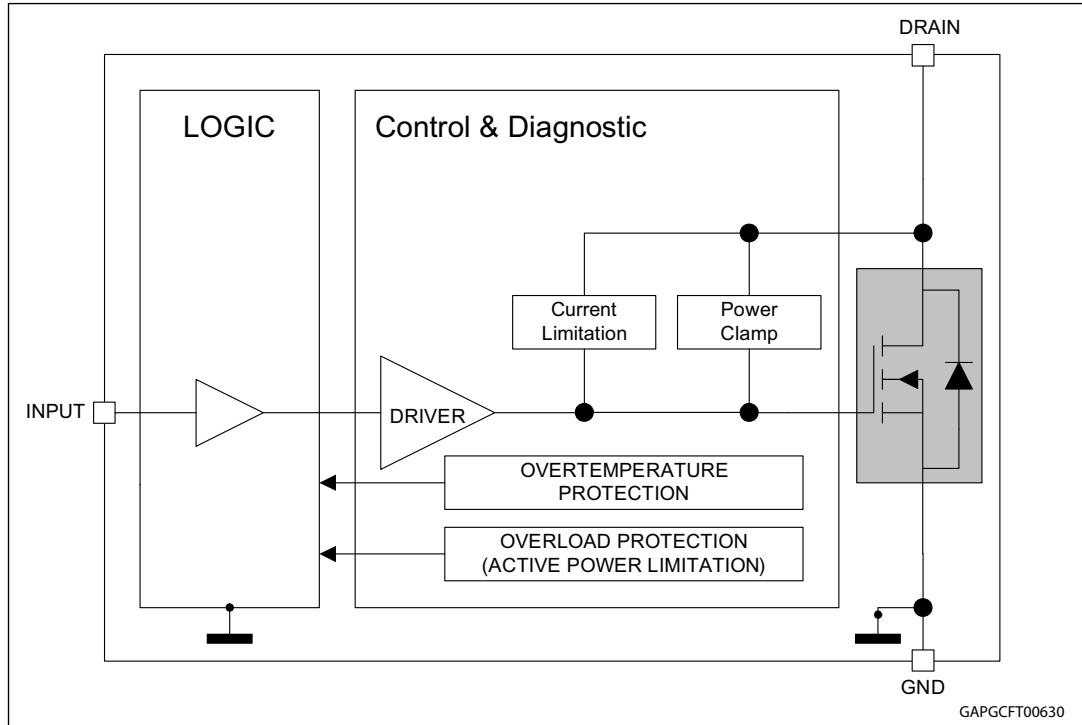

Figure 2. VNL5090S5-E block diagram

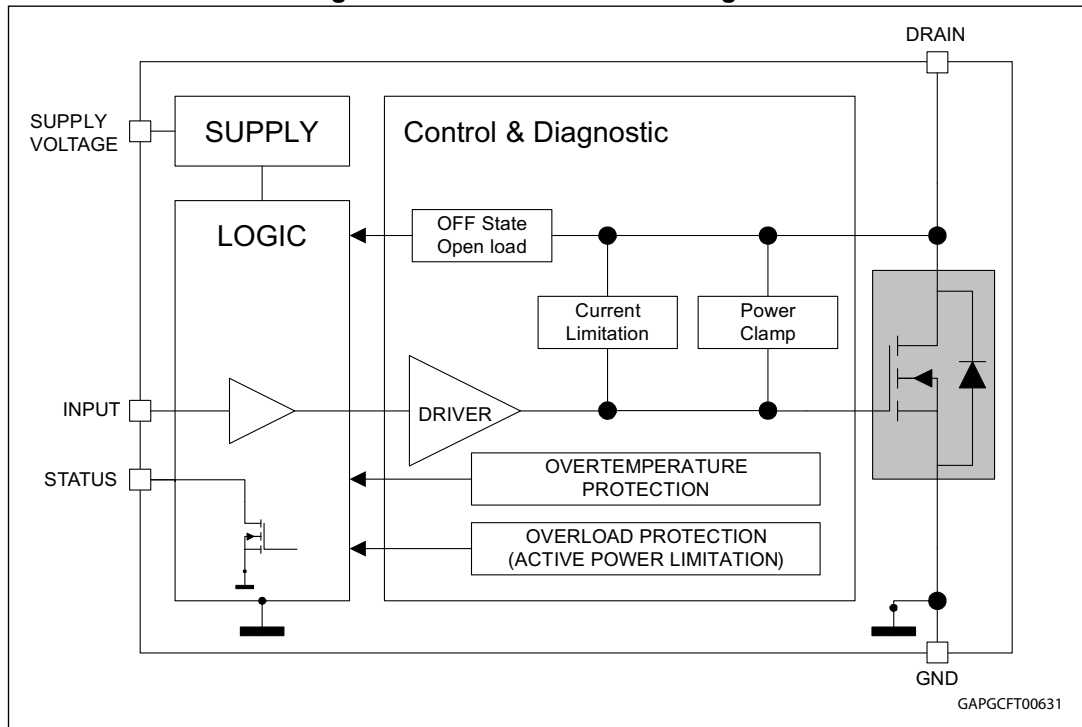

Table 2. Pin function

Name	Function
INPUT	Voltage controlled input pin with hysteresis, CMOS compatible; It controls output switch state ⁽¹⁾
DRAIN	PowerMOS drain
SOURCE	PowerMOS source and ground reference for the control section
SUPPLY VOLTAGE	Supply voltage connected to the signal part (5 V)
STATUS	Open drain digital diagnostic pin ⁽²⁾

1. Internally connected to V_{supply} in the VNL5090N3-E

2. Valid for VNL5090S5-E only.

Figure 3. VNL5090N3-E current and voltage conventions

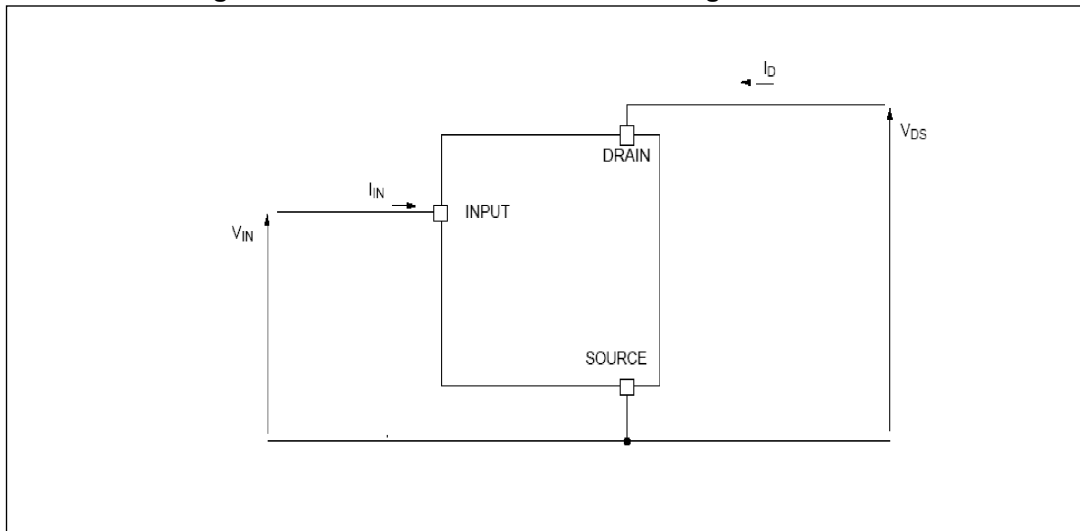

Figure 4. VNL5090S5-E current and voltage conventions

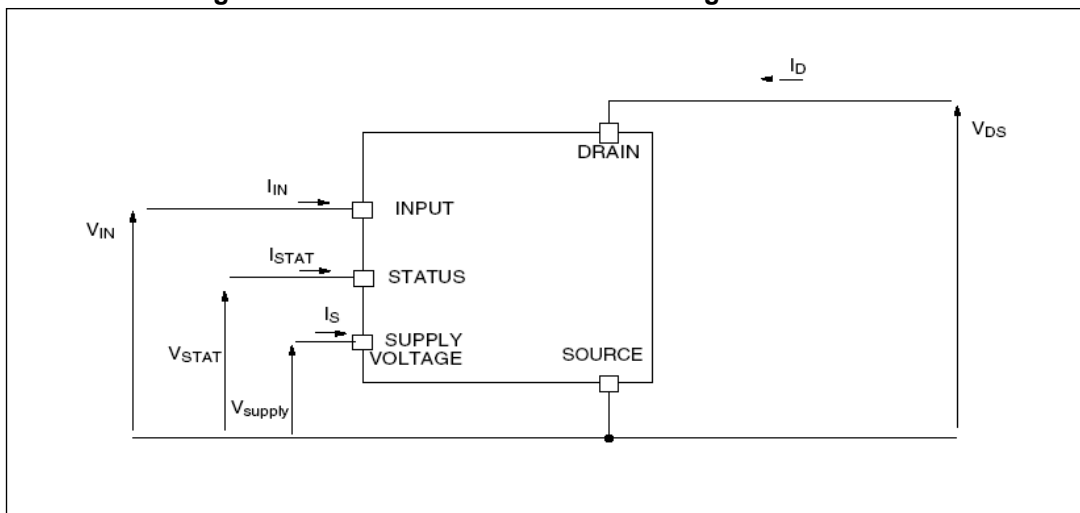

Figure 5. Configuration diagrams (top view)

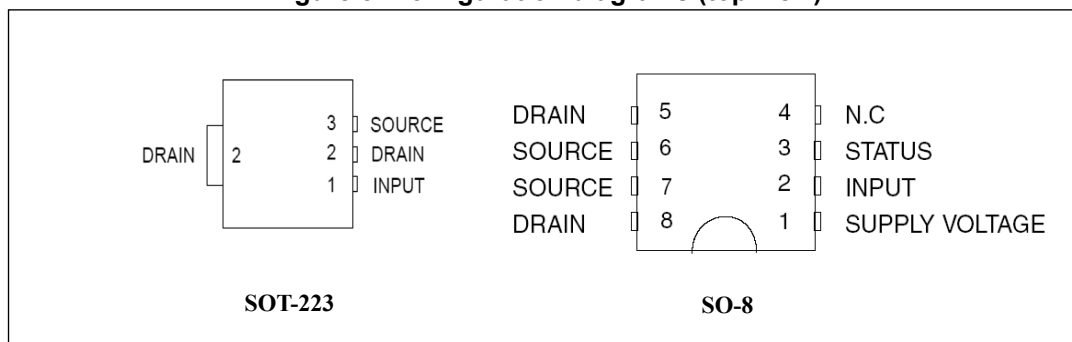

Table 3. Suggested connections for unused and N.C. pins

Connection / pin	Status	N.C.	Input
Floating	X ⁽¹⁾	X	X
To ground	Not allowed	X	Through 10 kΩ resistor

1. X: do not care.

2 Electrical specifications

2.1 Absolute maximum ratings

Stressing the device above the rating listed in the [Table 4](#) may cause permanent damage to the device. These are stress ratings only and operation of the device at these or any other conditions above those indicated in the operating sections of this specification is not implied. Exposure to absolute maximum rating conditions for extended periods may affect device reliability.

Table 4. Absolute maximum ratings

Symbol	Parameter	Value		Unit
		SOT-223	SO-8	
V_{DS}	Drain-source voltage ($V_{IN} = 0\text{ V}$)	Internally clamped		V
I_D	DC drain current	Internally limited		A
$-I_D$	Reverse DC drain current	12.5		A
I_S	DC supply current	—	-1 to 10	mA
I_{IN}	DC input current	-1 to 10		mA
I_{STAT}	DC status current	—	-1 to 10	mA
V_{ESD1}	Electrostatic discharge ($R = 1.5\text{ k}\Omega$; $C = 100\text{ pF}$) – DRAIN	5000		V
	– SUPPLY, INPUT, STATUS	4000		V
V_{ESD2}	Electrostatic discharge on output pin only ($R = 330\ \Omega$, $C = 150\text{ pF}$)	2000		V
T_j	Junction operating temperature	-40 to 150		°C
T_{stg}	Storage temperature	-55 to 150		°C
E_{AS}	Single pulse avalanche energy ($L = 1.1\text{ mH}$, $T_j = 150^\circ\text{C}$, $R_L = 0$, $I_{OUT} = I_{limL}$)	50		mJ

2.2 Thermal data

Table 5. Thermal data

Symbol	Parameter	Maximum value		Unit
		SOT-223	SO-8	
$R_{thj-amb}$	Thermal resistance junction-ambient	147 ⁽¹⁾	102	°C/W

1. When mounted on a standard single-sided FR4 board with 0.5 cm² of Cu (at least 35 μm thick) connected to all DRAIN pins

2.3 Electrical characteristics

Values specified in this section are for $V_{\text{supply}} = V_{\text{IN}} = 4.5 \text{ V to } 5.5 \text{ V}$, $-40^\circ\text{C} < T_j < 150^\circ\text{C}$, unless otherwise stated.

Table 6. PowerMOS section

Symbol	Parameter	Test conditions	Min.	Typ.	Max.	Unit
V_{supply}	Operating supply voltage		3.5	5	5.5	V
R_{ON}	ON-state resistance	$I_D = 1.6 \text{ A}$; $T_j = 25^\circ\text{C}$; $V_{\text{supply}} = V_{\text{IN}} = 5 \text{ V}$			90	m Ω
		$I_D = 1.6 \text{ A}$; $T_j = 150^\circ\text{C}$; $V_{\text{supply}} = V_{\text{IN}} = 5 \text{ V}$			180	
		$I_D = 1.6 \text{ A}$; $T_j = 150^\circ\text{C}$; $V_{\text{supply}} = V_{\text{IN}} = 4.5 \text{ V}^{(1)}$			190	
V_{CLAMP}	Drain-source clamp voltage	$V_{\text{IN}} = 0 \text{ V}$; $I_D = 1.6 \text{ A}$	41	46	52	V
V_{CLTH}	Drain-source clamp threshold voltage	$V_{\text{IN}} = 0 \text{ V}$; $I_D = 2 \text{ mA}$	36			V
I_{DSS}	OFF-state output current	$V_{\text{IN}} = 0 \text{ V}$; $V_{\text{DS}} = 13 \text{ V}$; $T_j = 25^\circ\text{C}$	0		3	μA
		$V_{\text{IN}} = 0 \text{ V}$; $V_{\text{DS}} = 13 \text{ V}$; $T_j = 125^\circ\text{C}$	0		5	

1. Valid only for VNL5090N3-E.

Table 7. Source drain diode

Symbol	Parameter	Test conditions	Min.	Typ.	Max.	Unit
V_{SD}	Forward on voltage	$I_D = 1.6 \text{ A}$; $V_{\text{IN}} = 0 \text{ V}$	—	0.8	—	V

Table 8. Input section (VNL5090N3-E only)

Symbol	Parameter	Test conditions	Min.	Typ.	Max.	Unit
I_{ISS}	Supply current from input pin	ON-state: $V_{\text{supply}} = V_{\text{IN}} = 5 \text{ V}$; $V_{\text{DS}} = 0 \text{ V}$		30	65	μA
V_{ICL}	Input clamp voltage	$I_S = 1 \text{ mA}$	5.5		7	V
		$I_S = -1 \text{ mA}$		-0.7		
V_{INTH}	Input threshold voltage	$V_{\text{DS}} = V_{\text{IN}}$; $I_D = 1 \text{ mA}$	1		3.5	V

Table 9. Status pin (VNL5090S5-E only)

Symbol	Parameter	Test conditions	Min.	Typ.	Max.	Unit
V_{STAT}	Status low output voltage	$I_{\text{STAT}} = 1 \text{ mA}$			0.5	V
I_{LSTAT}	Status leakage current	Normal operation, $V_{\text{STAT}} = 5 \text{ V}$			10	μA

Table 9. Status pin (VNL5090S5-E only) (continued)

Symbol	Parameter	Test conditions	Min.	Typ.	Max.	Unit
C_{STAT}	Status pin input capacitance	Normal operation, $V_{STAT} = 5\text{ V}$			100	pF
V_{STCL}	Status clamp voltage	$I_{STAT} = 1\text{ mA}$	5.5		7	V
		$I_{STAT} = -1\text{ mA}$		-0.7		

Table 10. Logic input (VNL5090S5-E only)

Symbol	Parameter	Test conditions	Min.	Typ.	Max.	Unit
V_{IL}	Low-level input voltage				0.9	V
I_{IL}	Low-level input current	$V_{IN} = 0.9\text{ V}$	1			μA
V_{IH}	High-level input voltage		2.1			V
I_{IH}	High-level input current	$V_{IN} = 2.1\text{ V}$			10	μA
$V_{I(hyst)}$	Input hysteresis voltage		0.13			V
V_{ICL}	Input clamp voltage	$I_{IN} = 1\text{ mA}$	5.5		7	V
		$I_{IN} = -1\text{ mA}$		-0.7		

Table 11. Openload detection (VNL5090S5-E only)

Symbol	Parameter	Test conditions	Min.	Typ.	Max.	Unit
V_{OI}	Openload OFF-state voltage detection threshold	$V_{IN} = 0\text{ V}$	0.6	1.2	1.7	V
$t_{d(oloff)}$	Delay between INPUT falling edge and STATUS falling edge in openload condition	$I_{OUT} = 0\text{ A}$	45	425	1100	μs

Table 12. Supply section (VNL5090S5-E only)

Symbol	Parameter	Test conditions	Min.	Typ.	Max.	Unit
I_S	Supply current	OFF-state; $T_j = 25^\circ\text{C}$; $V_{IN} = V_{DRAIN} = 0\text{ V}$;		10	25	μA
		ON-state; $V_{IN} = 5\text{ V}$; $V_{DS} = 0\text{ V}$		25	65	
V_{SCL}	Supply clamp voltage	$I_{SCL} = 1\text{ mA}$	5.5		7	V
		$I_{SCL} = -1\text{ mA}$		-0.7		

Table 13. Switching characteristics

Symbol	Parameter	Test conditions	SOT-223 ⁽¹⁾			SO-8			Unit
			Min.	Typ.	Max.	Min.	Typ.	Max.	
$t_{d(ON)}$	Turn-on delay time	$R_L = 8.2 \Omega$, $V_{CC} = 13 V^{(2)}$	—	8	—	—	8	—	μs
$t_{d(OFF)}$	Turn-off delay time	$R_L = 8.2 \Omega$, $V_{CC} = 13 V^{(2)}$	—	3.4	—	—	18	—	μs
t_r	Rise time	$R_L = 8.2 \Omega$, $V_{CC} = 13 V^{(2)}$	—	10	—	—	10	—	μs
t_f	Fall time	$R_L = 8.2 \Omega$, $V_{CC} = 13 V^{(2)}$	—	2.7	—	—	10	—	μs
W_{ON}	Switching energy losses at turn-on	$R_L = 8.2 \Omega$, $V_{CC} = 13 V^{(2)}$	—	57	—	—	57	—	μJ
W_{OFF}	Switching energy losses at turn-off	$R_L = 8.2 \Omega$, $V_{CC} = 13 V^{(2)}$	—	14	—	—	55	—	μJ

1. $3.5 V \leq V_{supply} = V_{IN} \leq 5.5 V$

2. See [Figure 6: Switching characteristics](#)

Note:

See [Figure 7: VNL5090N3-E application schematic](#) and [Figure 8: VNL5090S5-E application schematic](#)

Table 14. Protection and diagnostics

Symbol	Parameter	Test conditions ⁽¹⁾	Min.	Typ.	Max.	Unit
I_{limH}	DC short-circuit current	$V_{DS} = 13 V$; $V_{supply} = V_{IN} = 5 V$	13	18	25	A
I_{limL}	Short-circuit current during thermal cycling	$V_{DS} = 13 V$; $T_R < T_j < T_{TSD}$; $V_{supply} = V_{IN} = 5 V$		8		A
t_{dimL}	Step response current limit	$V_{DS} = 13 V$; $V_{input} = 5 V$		44		μs
T_{TSD}	Shutdown temperature		150	175	200	$^{\circ}C$
$T_R^{(2)}$	Reset temperature		$T_{RS} + 1$	$T_{RS} + 5$		$^{\circ}C$
$T_{RS}^{(2)}$	Thermal reset of STATUS		135			$^{\circ}C$
T_{HYST}	Thermal hysteresis ($T_{TSD} - T_R$)			7		$^{\circ}C$

1. $V_{supply} = V_{input}$ in VNL5090N3-E version.

2. Valid for VNL5090S5-E option.

Table 15. Truth table (VNL5090S5-E only)

Conditions	INPUT	DRAIN	STATUS
Normal operation	L	H	H
	H	L	H
Current limitation	L	H	H
	H	X	H
Overtemperature	L	H	H
	H	H	L
Undervoltage	L	H	X
	H	H	X
Output voltage < V_{OL}	L	L	L
	H	L	H

Figure 6. Switching characteristics

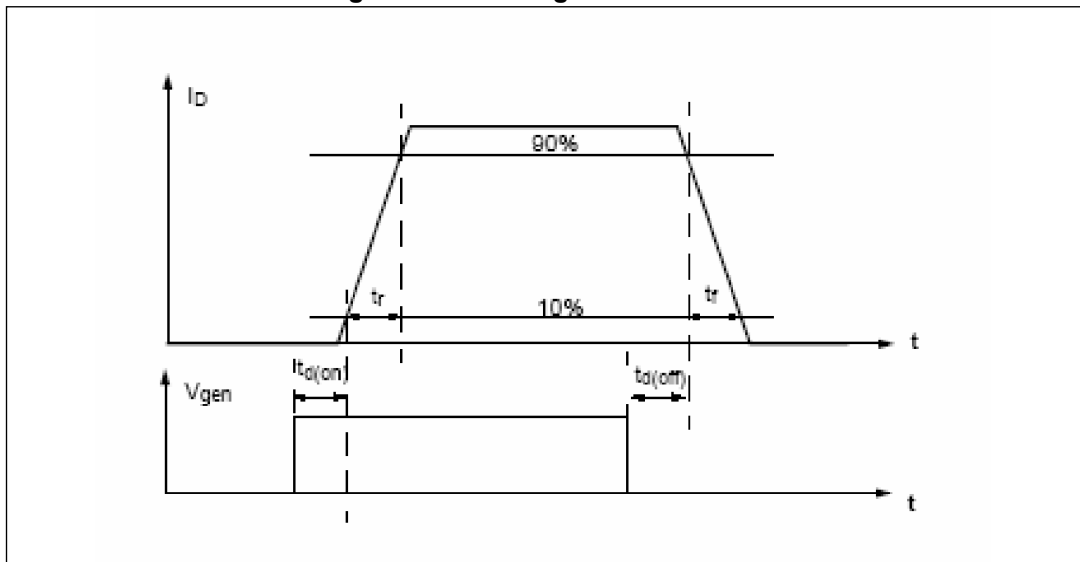

3 Application information

Figure 7. VNL5090N3-E application schematic

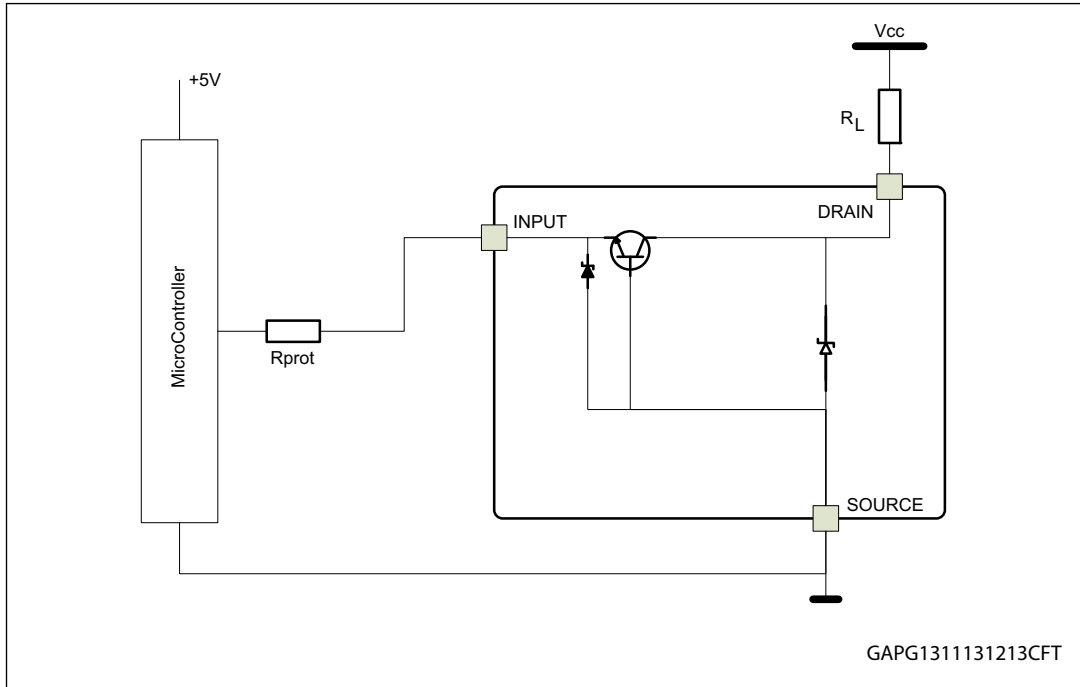
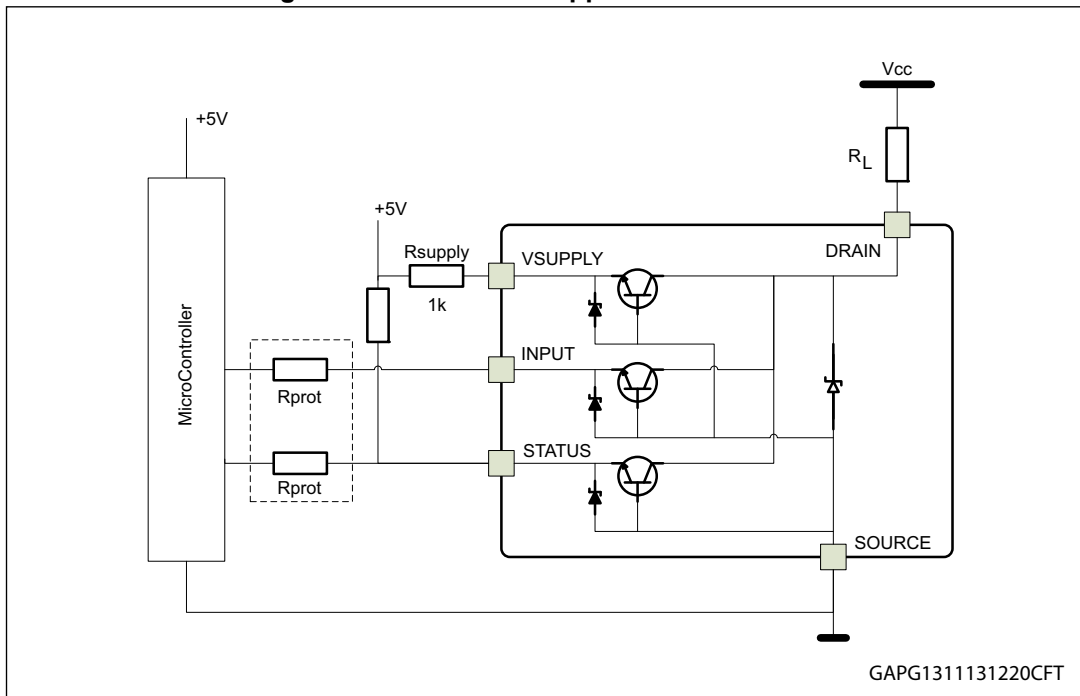

Figure 8. VNL5090S5-E application schematic



3.1 MCU I/O protection

ST suggests to insert a resistor (R_{prot}) in line to prevent the microcontroller I/O pins from latching up^(a). The value of these resistors is a compromise between the leakage current of microcontroller and the current required by the LSD I/Os (input levels compatibility) with the latch-up limit of microcontroller I/Os:

Equation 1

$$\frac{0.7}{I_{\text{latchup}}} \leq R_{\text{prot}} \leq \frac{(V_{\text{OH}\mu\text{C}} - V_{\text{IH}})}{I_{\text{IH max}}}$$

Let:

- $I_{\text{latchup}} \geq 20 \text{ mA}$
- $V_{\text{OH}\mu\text{C}} \geq 4.5 \text{ V}$
- $35 \Omega \leq R_{\text{prot}} \leq 100 \text{ K}\Omega$

Then, the recommended value is $R_{\text{prot}} = 1 \text{ K}\Omega$

Figure 9 shows the turn-off current drawn during the demagnetization.

a. In case of negative transient on the drain pin.

Figure 9. Maximum demagnetization energy ($V_{CC} = 16\text{ V}$)

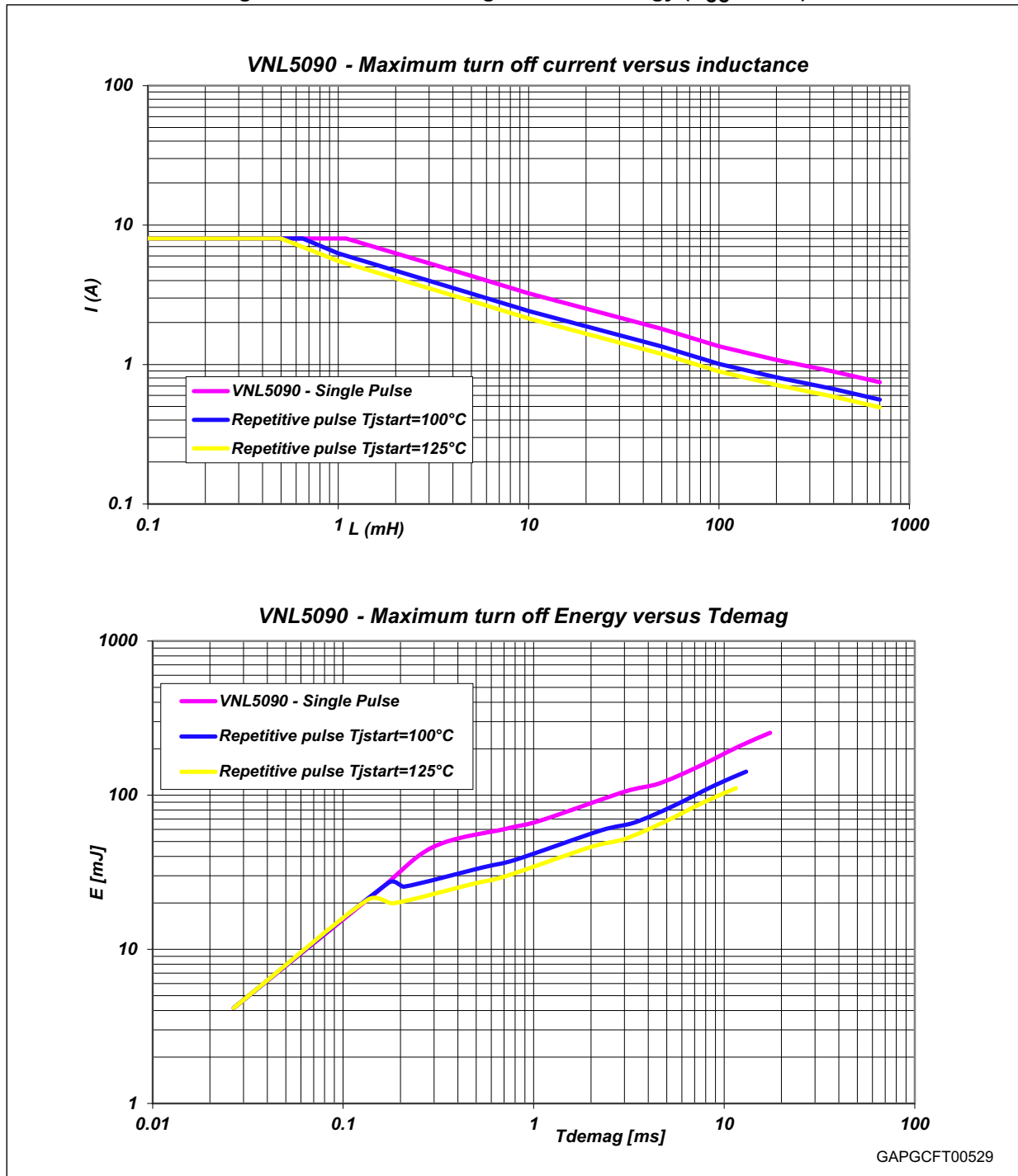

4 Package and PC board thermal data

4.1 SOT-223 thermal data

Figure 10. SOT-223 PC board

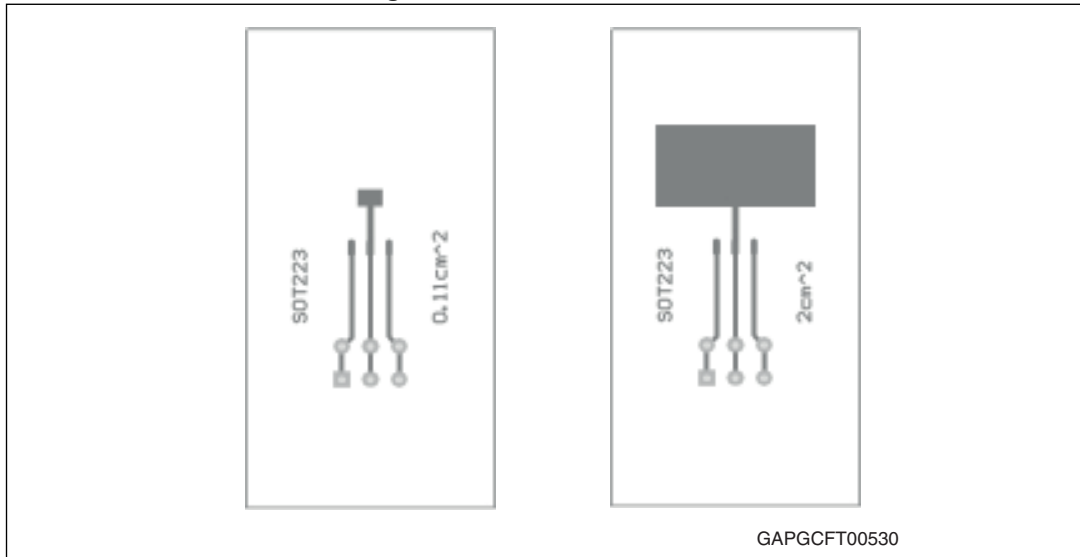

Note: Layout condition of R_{th} and Z_{th} measurements (PCB FR4 area = 30 mm x 58 mm, PCB thickness = 2 mm, Cu thickness = 35 μ m, copper areas: from minimum pad lay-out to 0.8 cm²).

Figure 11. SOT-223 $R_{thj-amb}$ vs PCB copper area in open box free air condition

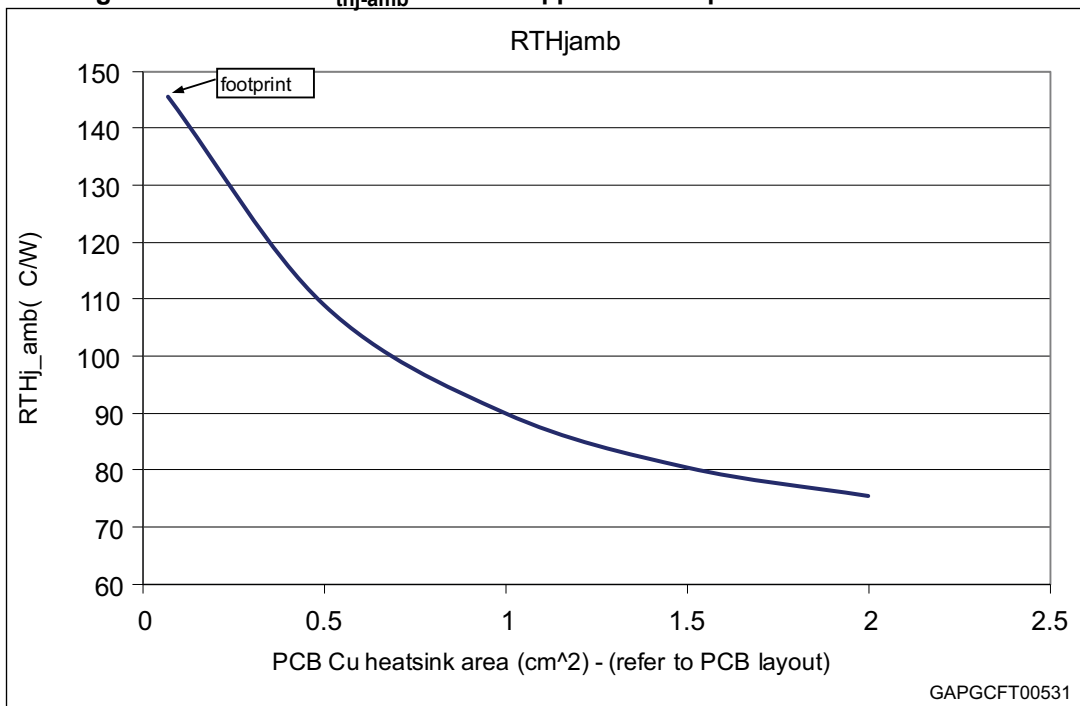
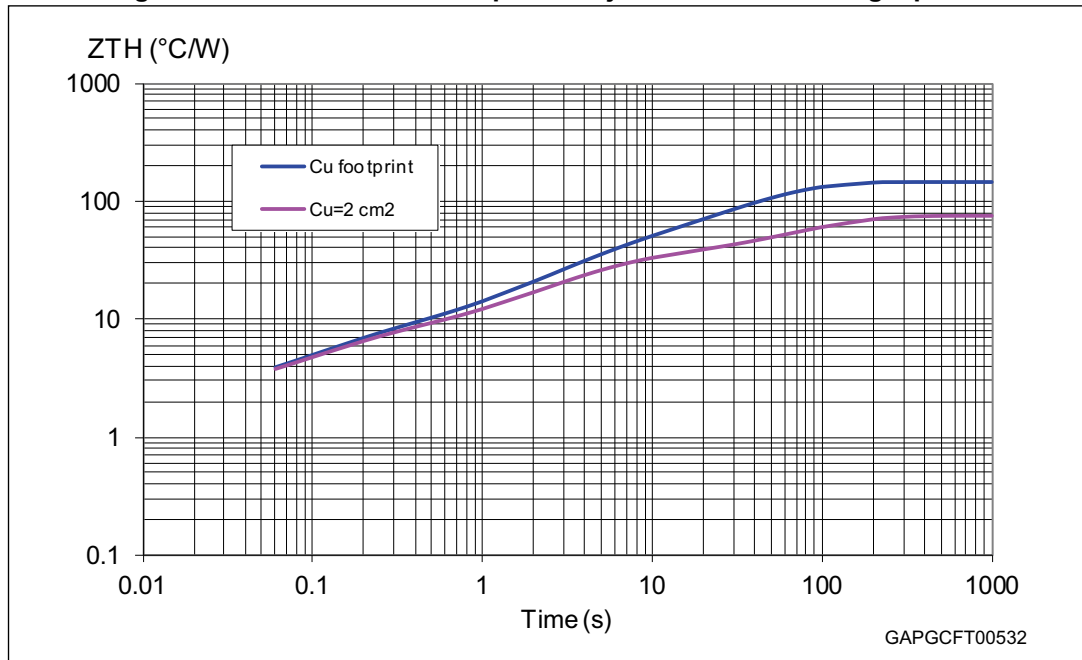

Figure 12. SOT-223 thermal impedance junction ambient single pulse



Equation 2: pulse calculation formula

$$Z_{TH\delta} = R_{TH} \cdot \delta + Z_{THtp}(1 - \delta)$$

where $\delta = t_p/T$

Figure 13. Thermal fitting model of a LSD in SOT-223

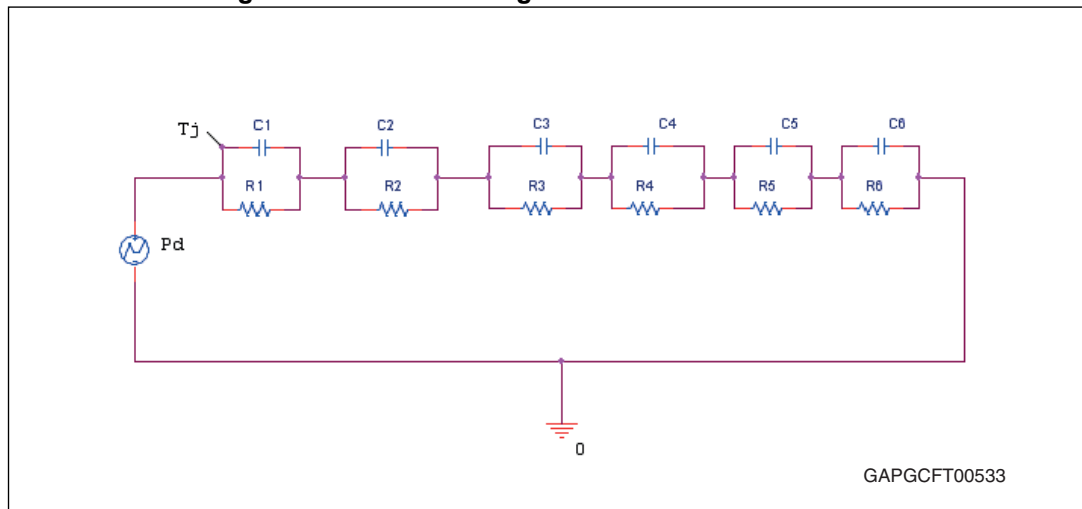

Note: The fitting model is a simplified thermal tool and is valid for transient evolutions where the embedded protections (power limitation or thermal cycling during thermal shutdown) are not triggered.

Table 16. SOT-223 thermal parameters

Area/island (cm ²)	Footprint	2
R1 (°C/W)	0.8	
R2 (°C/W)	1	
R3 (°C/W)	4.5	
R4 (°C/W)	24	
R5 (°C/W)	0.1	
R6 (°C/W)	115	45
C1 (W.s/°C)	0.00004	
C2 (W.s/°C)	0.0003	
C3 (W.s/°C)	0.03	
C4 (W.s/°C)	0.16	
C5 (W.s/°C)	1000	
C6 (W.s/°C)	0.4	2

4.2 SO-8 thermal data

Figure 14. SO-8 PC board

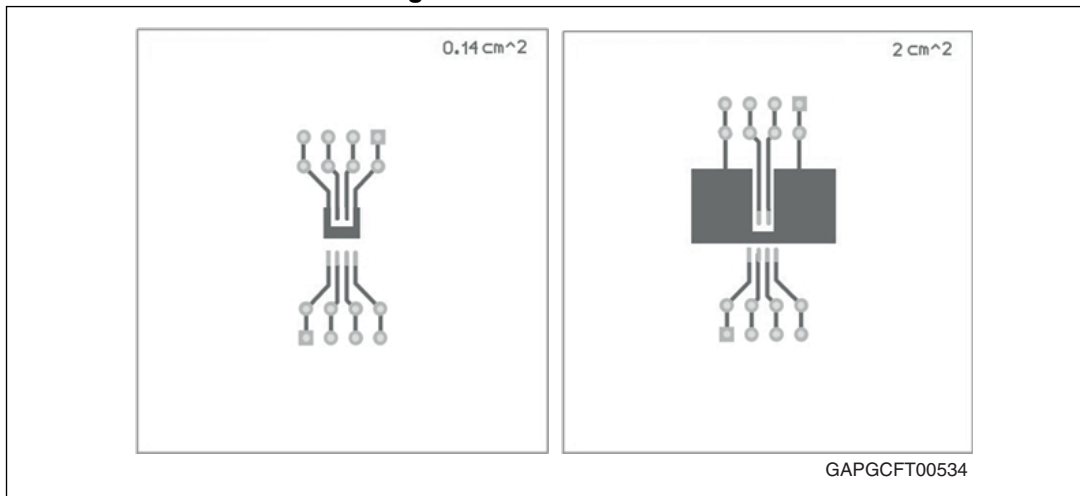

Note: Layout condition of R_{th} and Z_{th} measurements (PCB FR4 area = 58 mm x 58 mm, PCB thickness = 2 mm, Cu thickness = 35 μ m (front and back side), Copper areas: from minimum pad lay-out to 2 cm²).

Figure 15. SO-8 $R_{thj-amb}$ vs PCB copper area in open box free air condition

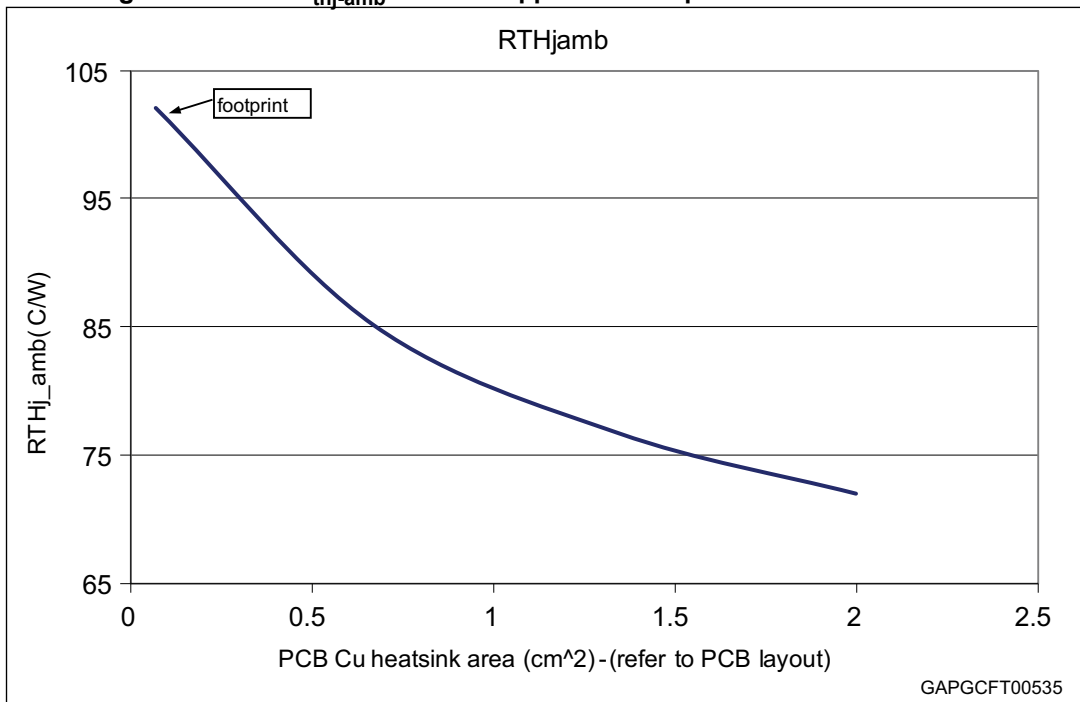
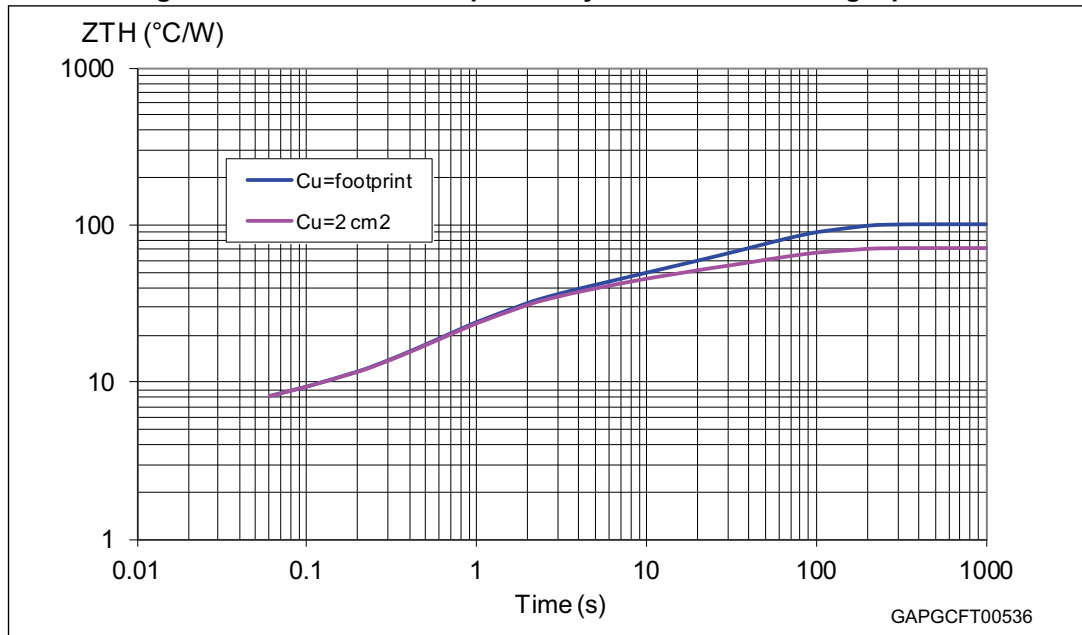

Figure 16. SO-8 thermal impedance junction ambient single pulse



Equation 3: pulse calculation formula

$$Z_{TH\delta} = R_{TH} \cdot \delta + Z_{THtp}(1 - \delta)$$

where $\delta = t_p/T$

Figure 17. Thermal fitting model of a LSD in SO-8

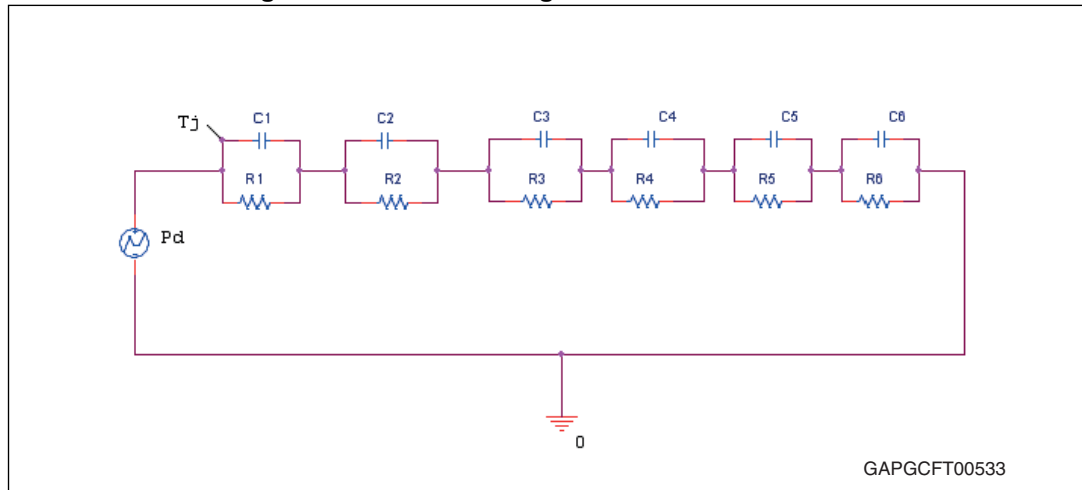

Note: The fitting model is a simplified thermal tool and is valid for transient evolutions where the embedded protections (power limitation or thermal cycling during thermal shutdown) are not triggered.

Table 17. SO-8 thermal parameters

Area/island (cm ²)	Footprint	2
R1 (°C/W)	0.8	
R2 (°C/W)	2.7	
R3 (°C/W)	3.5	
R4 (°C/W)	21	
R5 (°C/W)	16	
R6 (°C/W)	58	28
C1 (W.s/°C)	0.00005	
C2 (W.s/°C)	0.001	
C3 (W.s/°C)	0.0075	
C4 (W.s/°C)	0.045	
C5 (W.s/°C)	0.35	
C6 (W.s/°C)	1.05	2

5 Package and packing information

In order to meet environmental requirements, ST offers these devices in different grades of ECOPACK® packages, depending on their level of environmental compliance. ECOPACK® specifications, grade definitions and product status are available at: www.st.com. ECOPACK® is an ST trademark.

5.1 SOT-223 mechanical data

Figure 18. SOT-223 package dimensions

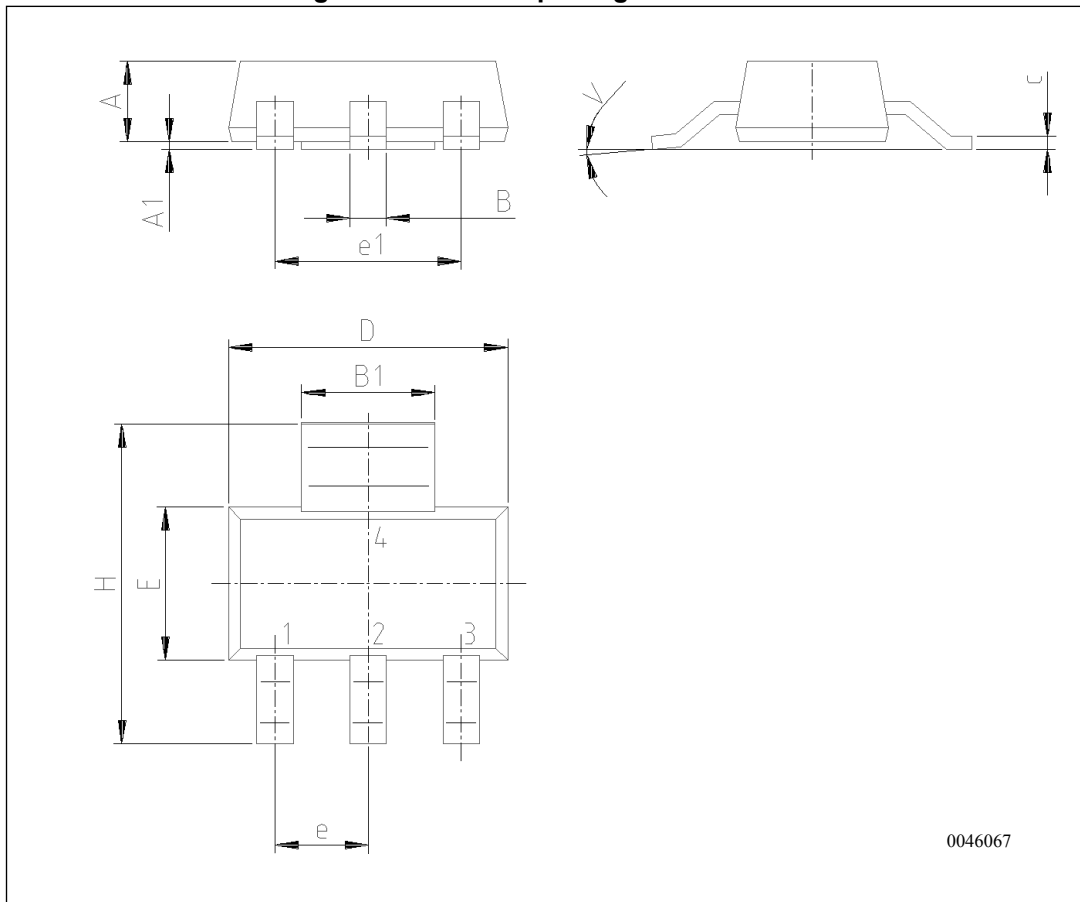

Table 18. SOT-223 mechanical data

DIM.	mm.			inch		
	Min.	Typ.	Max.	Min.	Typ.	Max.
A			1.8			0.071
B	0.6	0.7	0.85	0.024	0.027	0.033
B1	2.9	3	3.15	0.114	0.118	0.124
c	0.24	0.26	0.35	0.009	0.01	0.014
D	6.3	6.5	6.7	0.248	0.256	0.264
e		2.3			0.09	
e1		4.6			0.181	
E	3.3	3.5	3.7	0.13	0.138	0.146
H	6.7	7	7.3	0.264	0.276	0.287
V	10 (max)					
A1	0.02		0.1	0.0008		0.004

5.2 SO-8 mechanical data

Figure 19. SO-8 package dimensions

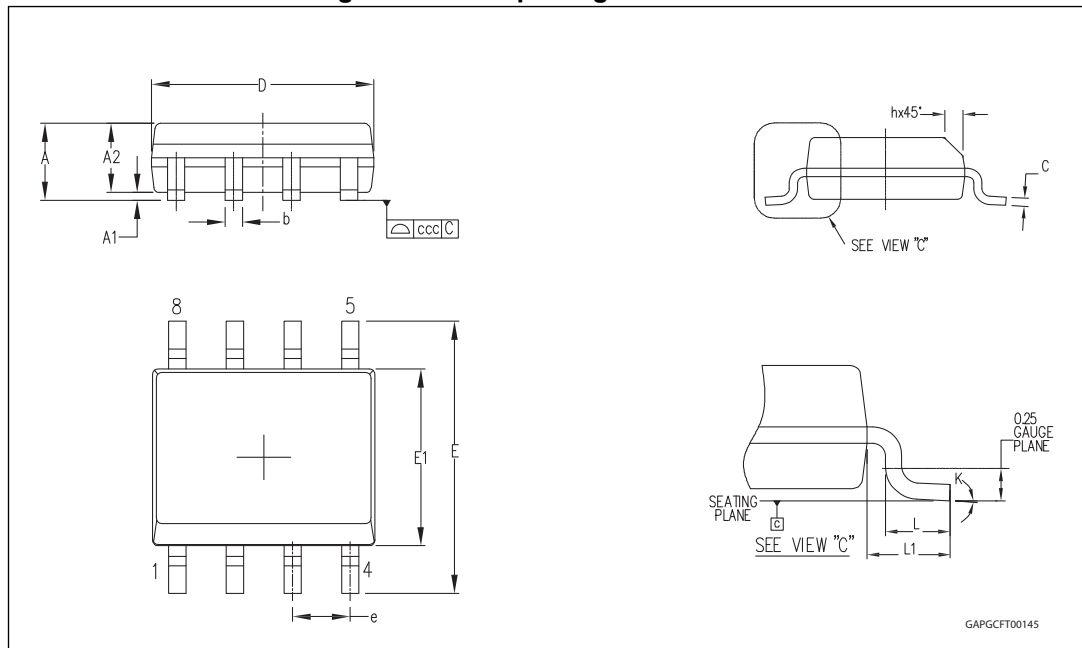

Table 19. SO-8 mechanical data

Symbol	Millimeters		
	Min.	Typ.	Max.
A			1.75
A1	0.10		0.25
A2	1.25		
b	0.28		0.48
c	0.17		0.23
D ⁽¹⁾	4.80	4.90	5.00
E	5.80	6.00	6.20
E1 ⁽²⁾	3.80	3.90	4.00
e		1.27	
h	0.25		0.50
L	0.40		1.27
L1		1.04	
k	0°		8°
ccc			0.10

1. Dimensions D does not include mold flash, protrusions or gate burrs. Mold flash, protrusions or gate burrs shall not exceed 0.15 mm in total (both side).
2. Dimension "E1" does not include interlead flash or protrusions. Interlead flash or protrusions shall not exceed 0.25 mm per side.

5.3 SOT-223 packing information

The devices can be packed in tube or tape and reel shipments (see the [Table 1: Devices summary on page 1](#)).

Figure 20. SOT-223 tape and reel shipment (suffix "TR")

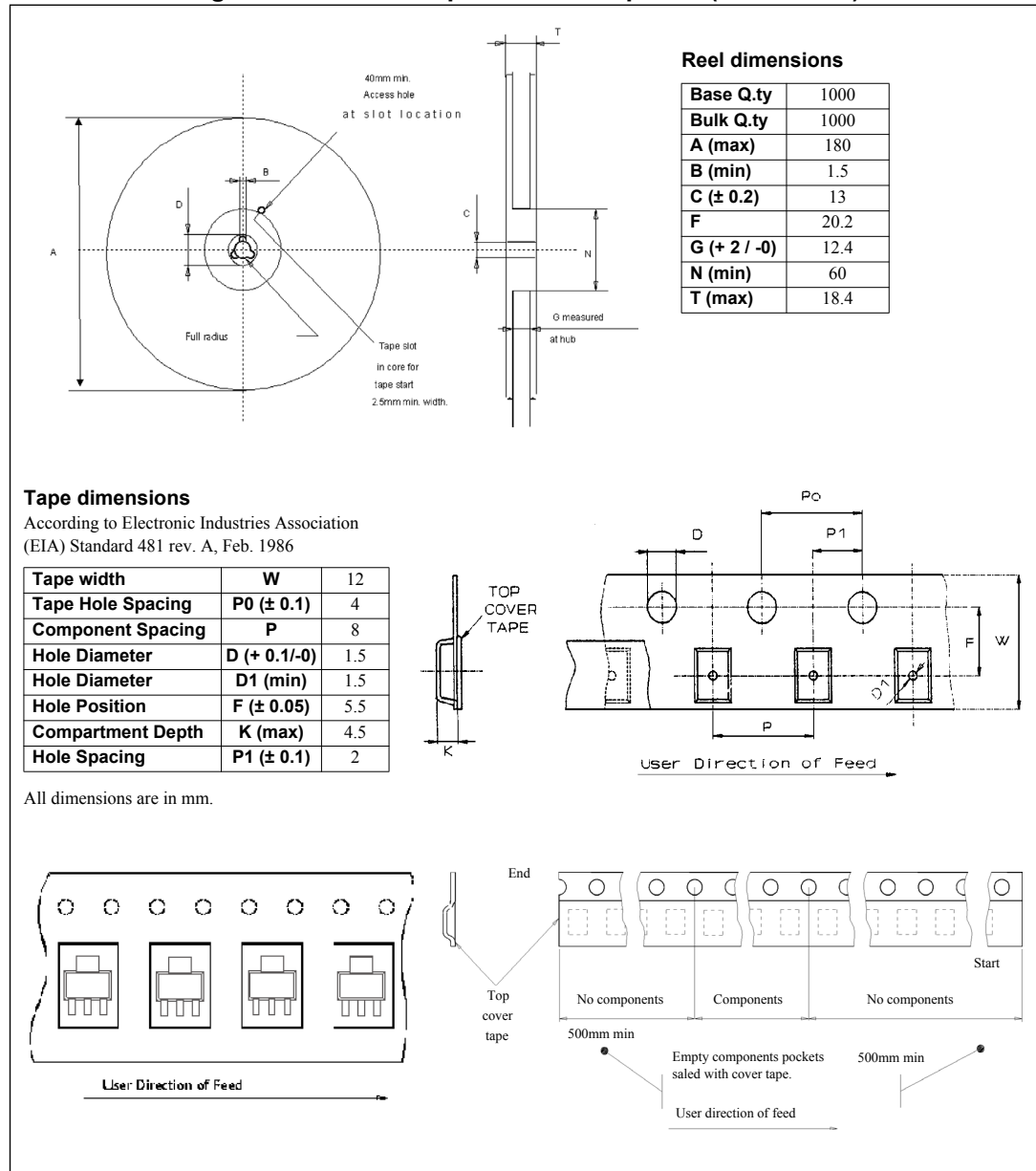

5.4 SO-8 packing information

Figure 21. SO-8 tube shipment (no suffix)

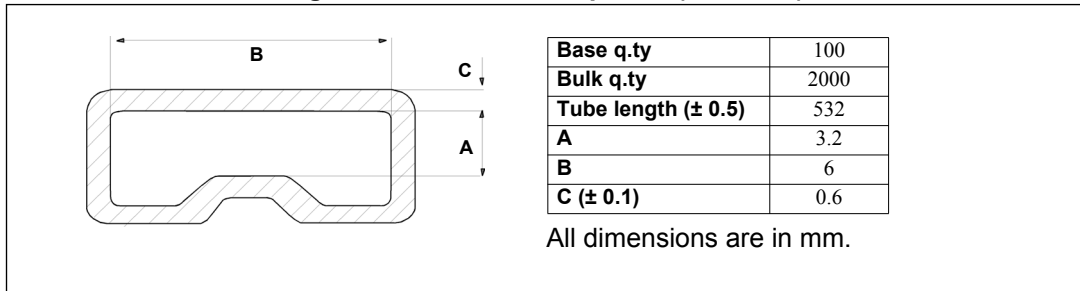
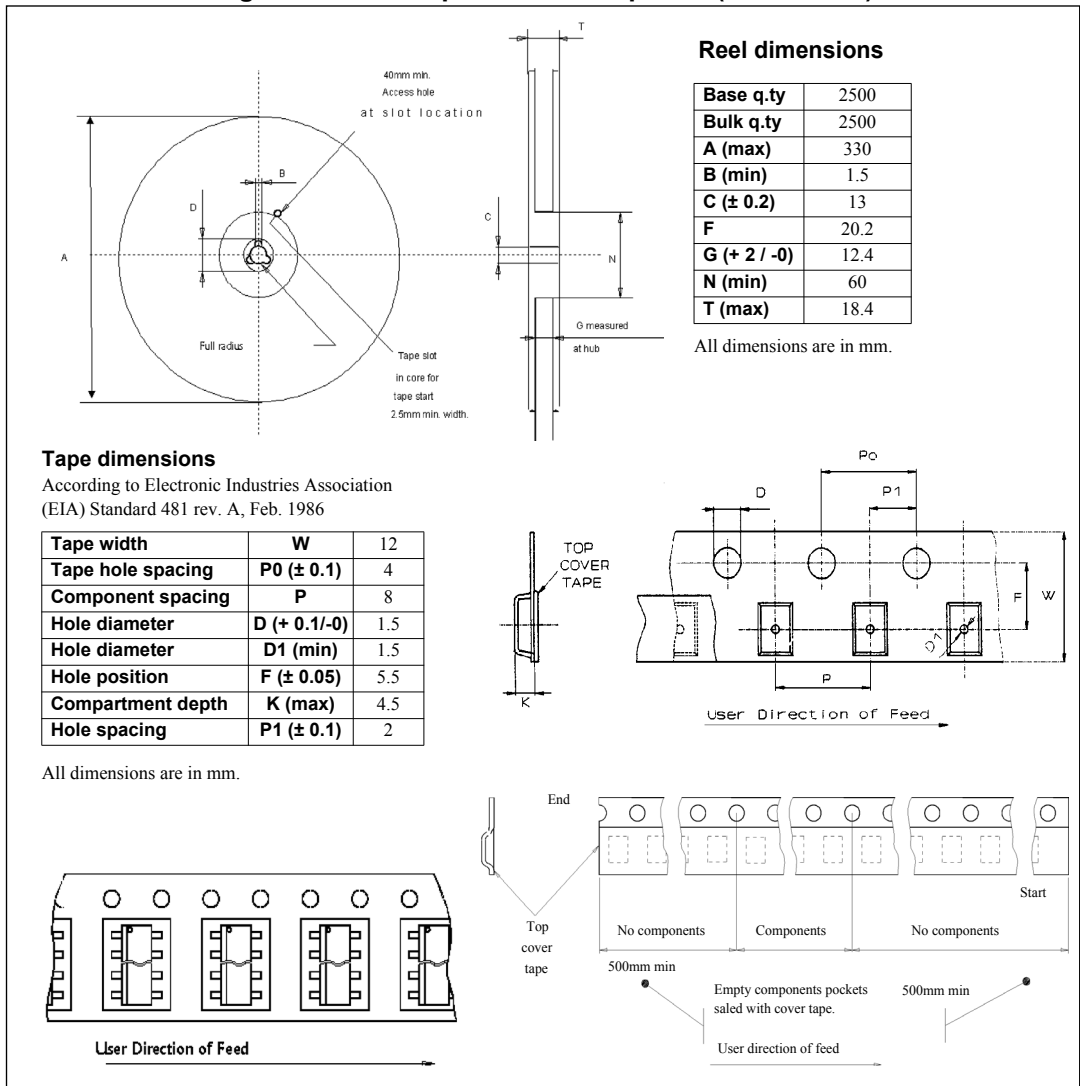

Figure 22. SO-8 tape and reel shipment (suffix “TR”)



6 Revision history

Table 20. Document revision history

Date	Revision	Changes
15-Dec-2011	1	Initial release.
20-Jan-2012	2	<i>Table 4: Absolute maximum ratings:</i> – I_D : updated value
18-Apr-2012	3	Updated <i>Features</i> list
10-Aug-2012	4	Updated <i>Table 13: Switching characteristics</i>
18-Sep-2013	5	Updated disclaimer.
13-Nov-2013	6	Updated <i>Features</i> list <i>Table 8: Input section:</i> – I_{SS} : updated maximum value <i>Table 12: Supply section (VNL5090S5-E only):</i> – I_S : updated maximum value Updated <i>Figure 7: VNL5090N3-E application schematic</i> and <i>Figure 8: VNL5090S5-E application schematic</i> Updated <i>Section 3.1: MCU I/O protection</i>
01-Apr-2015	7	Updated <i>Table 1: Devices summary</i>
20-Nov-2018	8	Updated title and features in cover page. Removed note from table 8. Updated A (max) value in Reel dimensions table, present in <i>Figure 20: SOT-223 tape and reel shipment (suffix "TR")</i> . Minor text changes.

IMPORTANT NOTICE – PLEASE READ CAREFULLY

STMicroelectronics NV and its subsidiaries (“ST”) reserve the right to make changes, corrections, enhancements, modifications, and improvements to ST products and/or to this document at any time without notice. Purchasers should obtain the latest relevant information on ST products before placing orders. ST products are sold pursuant to ST’s terms and conditions of sale in place at the time of order acknowledgement.

Purchasers are solely responsible for the choice, selection, and use of ST products and ST assumes no liability for application assistance or the design of Purchasers’ products.

No license, express or implied, to any intellectual property right is granted by ST herein.

Resale of ST products with provisions different from the information set forth herein shall void any warranty granted by ST for such product.



ST and the ST logo are trademarks of ST. All other product or service names are the property of their respective owners.

Information in this document supersedes and replaces information previously supplied in any prior versions of this document.

© 2018 STMicroelectronics – All rights reserved

Looking for pricing, stock, or lifecycle information?

Click below to explore more details on WIN SOURCE:

-  [View VNL5090N3TR-E on WIN SOURCE](#)
-  [STMicroelectronics Information](#)

Optimize Your Supply Chain with WIN SOURCE Solutions

-  Global Sourcing Solution
-  Obsolete Management
-  Cost Control Management
-  Shortage Management
-  Alternative Solution
-  Excess Inventory Management