



# THE DATASHEET OF STP5N105K5



## N-channel 1050 V, 2.9 $\Omega$ typ., 3 A MDmesh™ K5 Power MOSFET in a TO-220 package

Datasheet - production data

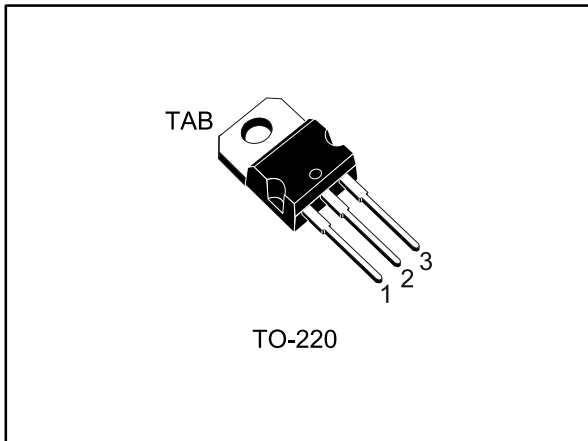
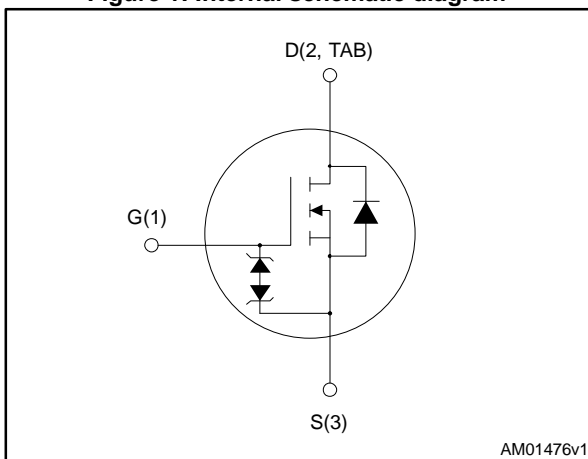

Figure 1: Internal schematic diagram



### Features

Order code	V <sub>DS</sub>	R <sub>DS(on)</sub> max.	I <sub>D</sub>	P <sub>TOT</sub>
STP5N105K5	1050 V	3.5 $\Omega$	3 A	85 W

- Worldwide best FOM (figure of merit)
- Ultra low gate charge
- 100% avalanche tested
- Zener-protected

### Applications

- Switching applications

### Description

This N-channel Zener-protected Power MOSFET is designed using ST's revolutionary avalanche-rugged very high voltage MDmesh™ K5 technology, based on an innovative proprietary vertical structure. The result is a dramatic reduction in on-resistance, and ultra-low gate charge for applications which require superior power density and high efficiency.

Table 1: Device summary

Order code	Marking	Package	Packaging
STP5N105K5	5N105K5	TO-220	Tube

---

**Contents**

<b>1</b>	<b>Electrical ratings .....</b>	<b>3</b>
<b>2</b>	<b>Electrical characteristics .....</b>	<b>4</b>
	2.1 Electrical characteristics (curves).....	6
<b>3</b>	<b>Test circuits .....</b>	<b>9</b>
<b>4</b>	<b>Package mechanical data .....</b>	<b>10</b>
	4.1 TO-220 package mechanical data .....	11
<b>5</b>	<b>Revision history .....</b>	<b>13</b>

# 1 Electrical ratings

Table 2: Absolute maximum ratings

Symbol	Parameter	Value	Unit
V <sub>GS</sub>	Gate- source voltage	± 30	V
I <sub>D</sub>	Drain current (continuous) at T <sub>C</sub> = 25 °C	3	A
I <sub>D</sub>	Drain current (continuous) at T <sub>C</sub> = 100 °C	2	A
I <sub>DM</sub> <sup>(1)</sup>	Drain current (pulsed)	12	A
P <sub>TOT</sub>	Total dissipation at T <sub>C</sub> = 25 °C	85	W
I <sub>AR</sub>	Max current during repetitive or single pulse avalanche	1	A
E <sub>AS</sub>	Single pulse avalanche energy (starting T <sub>J</sub> = 25 °C, I <sub>D</sub> =I <sub>AS</sub> , V <sub>DD</sub> = 50 V)	85	mJ
dv/dt <sup>(2)</sup>	Peak diode recovery voltage slope	4.5	V/ns
dv/dt <sup>(3)</sup>	MOSFET dv/dt ruggedness	50	V/ns
T <sub>j</sub>	Operating junction temperature	- 55 to 150	°C
T <sub>stg</sub>	Storage temperature		

**Notes:**

<sup>(1)</sup>Pulse width limited by safe operating area

<sup>(2)</sup>I<sub>SD</sub> ≤ 3 A, di/dt ≤ 100 A/μs, V<sub>DS(peak)</sub> ≤ V<sub>(BR)DSS</sub>

<sup>(3)</sup>V<sub>DS</sub> ≤ 840 V

Table 3: Thermal data

Symbol	Parameter	Value	Unit
R <sub>thj-case</sub>	Thermal resistance junction-case max	1.47	°C/W
R <sub>thj-amb</sub>	Thermal resistance junction-amb max	62.5	°C/W

## 2 Electrical characteristics

(T<sub>CASE</sub> = 25 °C unless otherwise specified).

**Table 4: On/off states**

Symbol	Parameter	Test conditions	Min.	Typ.	Max.	Unit
V <sub>(BR)DSS</sub>	Drain-source breakdown voltage	V <sub>GS</sub> = 0, I <sub>D</sub> = 1 mA	1050			V
I <sub>DSS</sub>	Zero gate voltage drain current	V <sub>GS</sub> = 0, V <sub>DS</sub> = 1050 V			1	μA
		V <sub>GS</sub> = 0, V <sub>DS</sub> = 1050 V, T <sub>C</sub> = 125 °C			50	μA
I <sub>GSS</sub>	Gate body leakage current	V <sub>DS</sub> = 0, V <sub>GS</sub> = ± 20 V			±10	μA
V <sub>GS(th)</sub>	Gate threshold voltage	V <sub>DS</sub> = V <sub>GS</sub> , I <sub>D</sub> = 100 μA	3	4	5	V
R <sub>DS(on)</sub>	Static drain-source on-resistance	V <sub>GS</sub> = 10 V, I <sub>D</sub> = 1.5 A		2.9	3.5	Ω

**Table 5: Dynamic**

Symbol	Parameter	Test conditions	Min.	Typ.	Max.	Unit
C <sub>iSS</sub>	Input capacitance	V <sub>DS</sub> = 100 V, f = 1 MHz, V <sub>GS</sub> = 0	-	210	-	pF
C <sub>oSS</sub>	Output capacitance		-	16	-	pF
C <sub>rSS</sub>	Reverse transfer capacitance		-	0.5	-	pF
C <sub>o(tr)</sub> <sup>(1)</sup>	Equivalent capacitance time related	V <sub>GS</sub> = 0, V <sub>DS</sub> = 0 to 840 V	-	26	-	pF
C <sub>o(er)</sub> <sup>(2)</sup>	Equivalent capacitance energy related		-	10	-	pF
R <sub>G</sub>	Intrinsic gate resistance	f = 1MHz open drain	-	9	-	Ω
Q <sub>g</sub>	Total gate charge	V <sub>DD</sub> = 840 V, I <sub>D</sub> = 3 A	-	12.5	-	nC
Q <sub>gs</sub>	Gate-source charge	V <sub>GS</sub> = 10 V	-	2	-	nC
Q <sub>gd</sub>	Gate-drain charge	Figure 16: "Gate charge test circuit"	-	9.5	-	nC

**Notes:**

<sup>(1)</sup>Time related is defined as a constant equivalent capacitance giving the same charging time as C<sub>oSS</sub> when V<sub>DS</sub> increases from 0 to 80% V<sub>DSS</sub>

<sup>(2)</sup>Energy related is defined as a constant equivalent capacitance giving the same stored energy as C<sub>oSS</sub> when V<sub>DS</sub> increases from 0 to 80% V<sub>DSS</sub>

**Table 6: Switching times**

Symbol	Parameter	Test conditions	Min.	Typ.	Max.	Unit
t <sub>d(on)</sub>	Turn-on delay time	V <sub>DD</sub> = 525V, I <sub>D</sub> = 1.5 A, R <sub>G</sub> = 4.7 Ω, V <sub>GS</sub> = 10 V Figure 18: "Unclamped inductive load test circuit"	-	15.5	-	ns
t <sub>r</sub>	Rise time		-	8.5	-	ns
t <sub>d(off)</sub>	Turn-off delay time		-	31	-	ns
t <sub>f</sub>	Fall time		-	24	-	ns

Table 7: Source drain diode

Symbol	Parameter	Test conditions	Min.	Typ.	Max.	Unit
$I_{SD}$	Source-drain current		-		3	A
$I_{SDM}$	Source-drain current (pulsed)				12	A
$V_{SD}^{(1)}$	Forward on voltage	$I_{SD} = 3\text{ A}, V_{GS} = 0$	-		1.5	V
$t_{rr}$	Reverse recovery time	$I_{SD} = 3\text{ A}, V_{DD} = 60\text{ V}$ $di/dt = 100\text{ A}/\mu\text{s}$ , <i>Figure 17: " Test circuit for inductive load switching and diode recovery times"</i>	-	400		ns
$Q_{rr}$	Reverse recovery charge		-	2.3		$\mu\text{C}$
$I_{RRM}$	Reverse recovery current		-	12		A
$t_{rr}$	Reverse recovery time	$I_{SD} = 3\text{ A}, V_{DD} = 60\text{ V}$ $di/dt = 100\text{ A}/\mu\text{s}$ , $T_j = 150\text{ }^\circ\text{C}$ <i>Figure 17: " Test circuit for inductive load switching and diode recovery times"</i>	-	560		ns
$Q_{rr}$	Reverse recovery charge		-	3.1		$\mu\text{C}$
$I_{RRM}$	Reverse recovery current		-	11		A

**Notes:**

<sup>(1)</sup>Pulsed: pulse duration = 300 $\mu\text{s}$ , duty cycle 1.5%

Table 8: Gate-source Zener diode

Symbol	Parameter	Test conditions	Min	Typ.	Max.	Unit
$V_{(BR)GSO}$	Gate-source breakdown voltage	$I_{GS} = \pm 1\text{ mA}, I_D = 0$	30	-	-	V

The built-in back-to-back Zener diodes have specifically been designed to enhance the device's ESD capability. In this respect the Zener voltage is appropriate to achieve an efficient and cost-effective intervention to protect the device's integrity. These integrated Zener diodes thus avoid the usage of external components.

## 2.1 Electrical characteristics (curves)

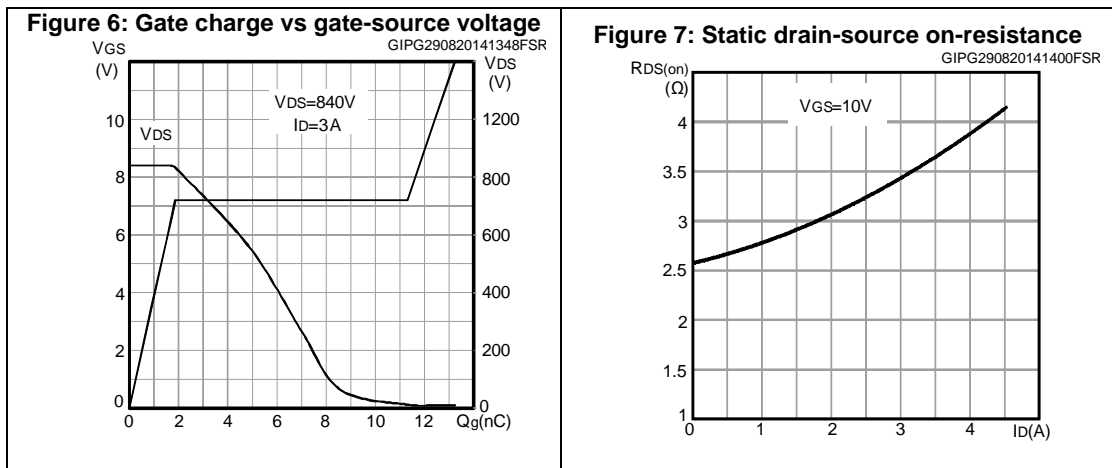
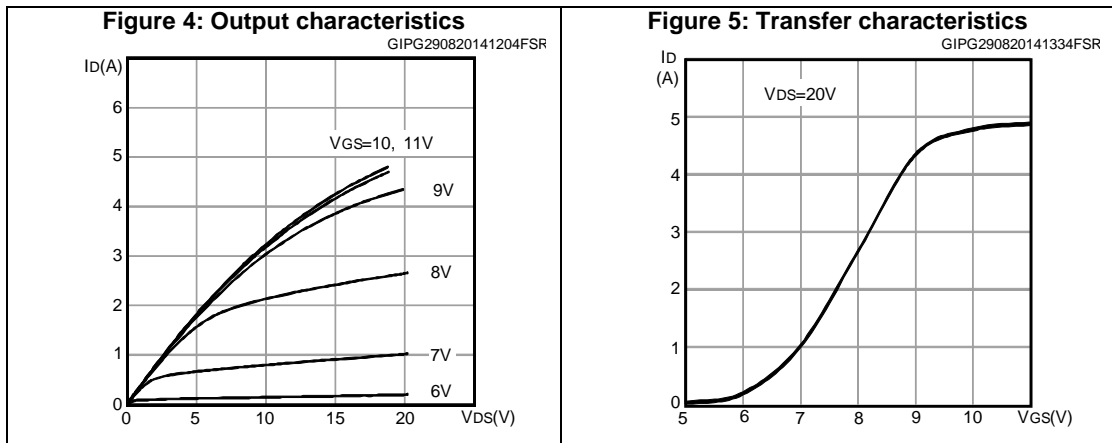
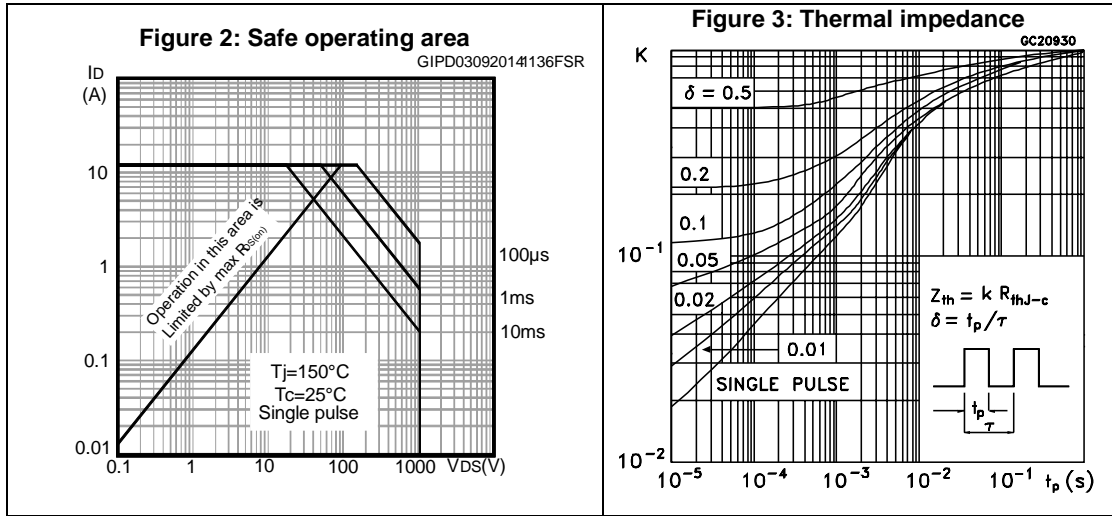

Figure 8: Capacitance variations

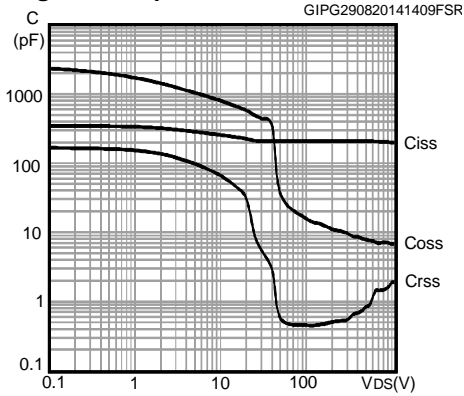

Figure 9: Source-drain diode forward characteristics

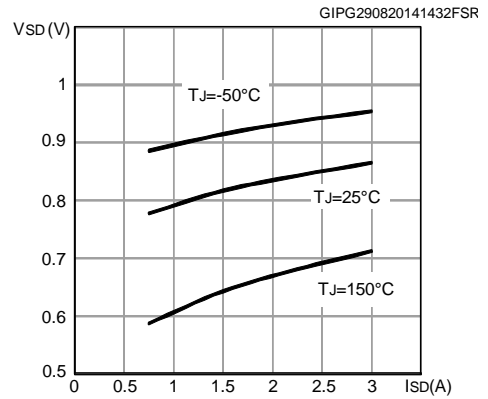

Figure 10: Normalized gate threshold voltage vs temperature

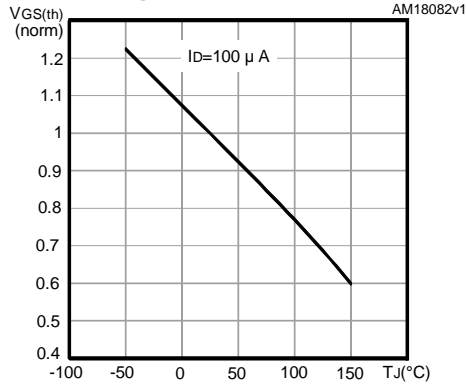

Figure 11: Normalized on-resistance vs temperature

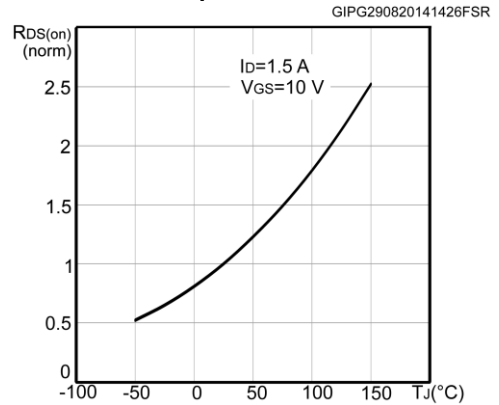

Figure 12: Normalized V(BR)DSS vs temperature

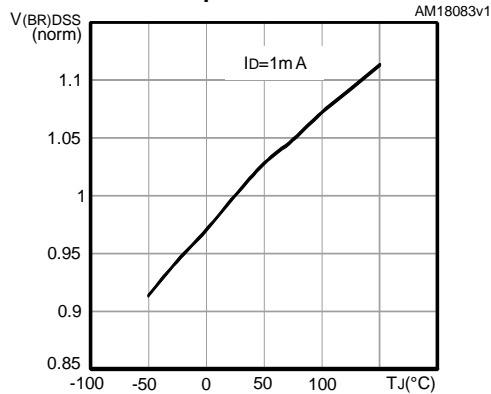

Figure 13: Maximum avalanche energy

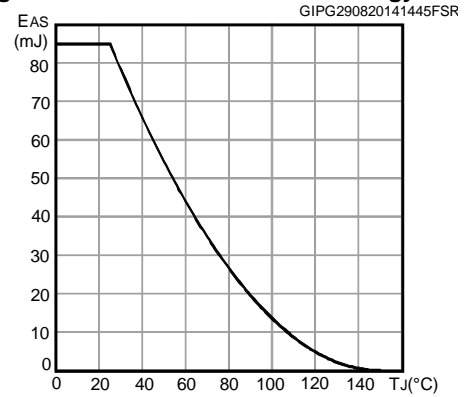
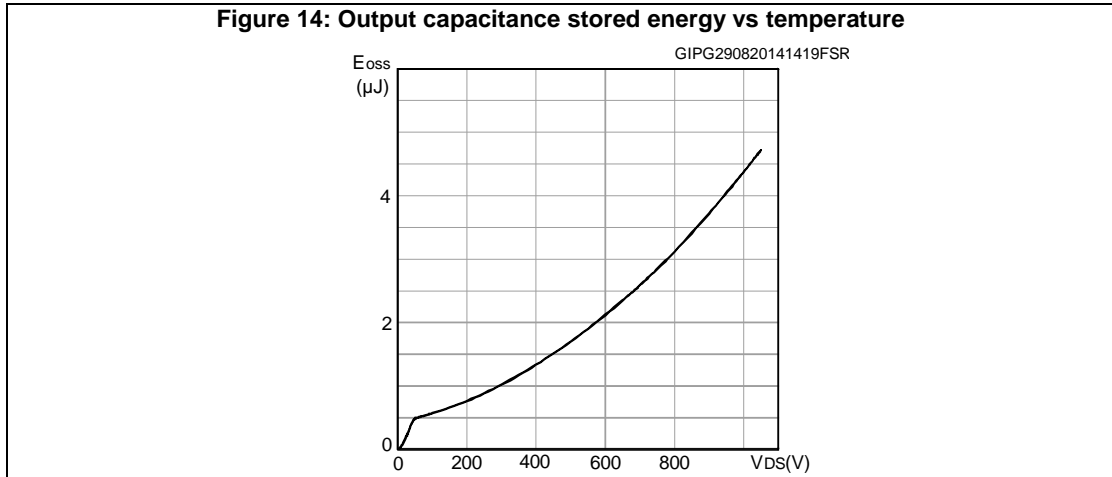
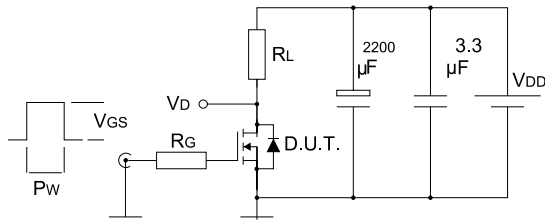

Figure 14: Output capacitance stored energy vs temperature



### 3 Test circuits

**Figure 15: Switching times test circuit for resistive load**



AM01468v1

**Figure 16: Gate charge test circuit**

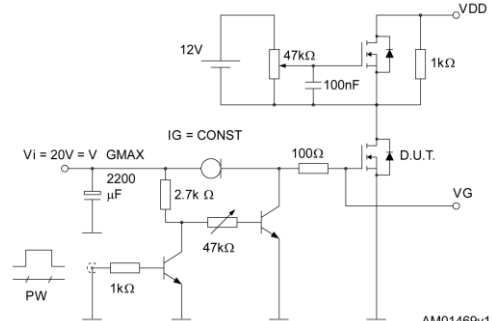

AM01469v1

**Figure 17: Test circuit for inductive load switching and diode recovery times**

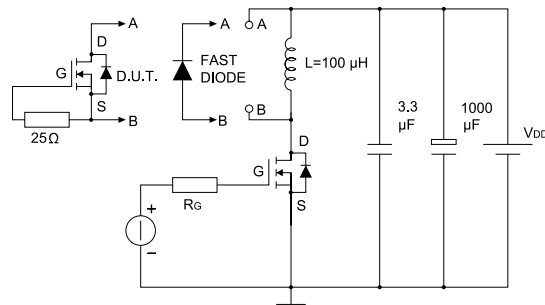

AM01470v1

**Figure 18: Unclamped inductive load test circuit**

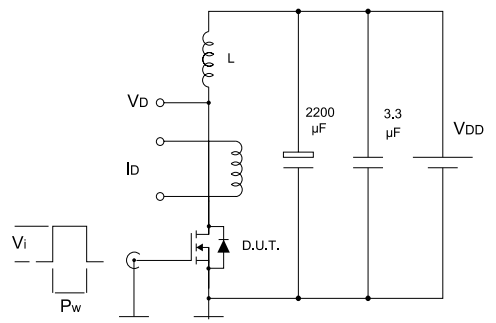

AM01471v1

**Figure 19: Unclamped inductive waveform**

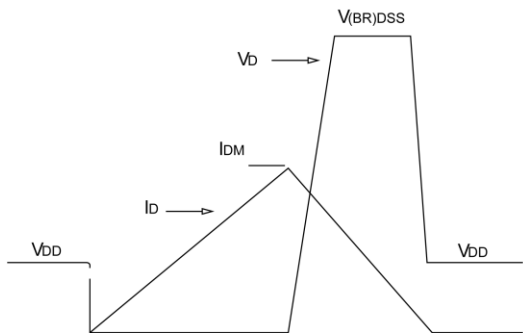

AM01472v1

**Figure 20: Switching time waveform**

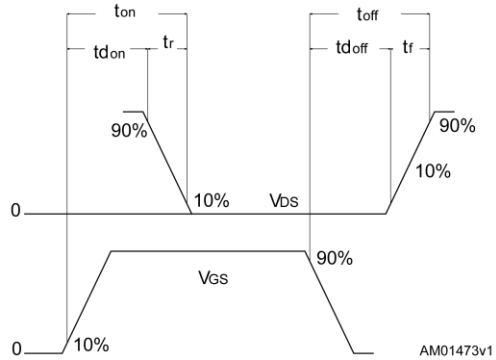

AM01473v1

## 4 Package mechanical data

In order to meet environmental requirements, ST offers these devices in different grades of ECOPACK® packages, depending on their level of environmental compliance. ECOPACK® specifications, grade definitions and product status are available at: [www.st.com](http://www.st.com). ECOPACK® is an ST trademark.

### 4.1 TO-220 package mechanical data

Figure 21: TO-220 type A package outline

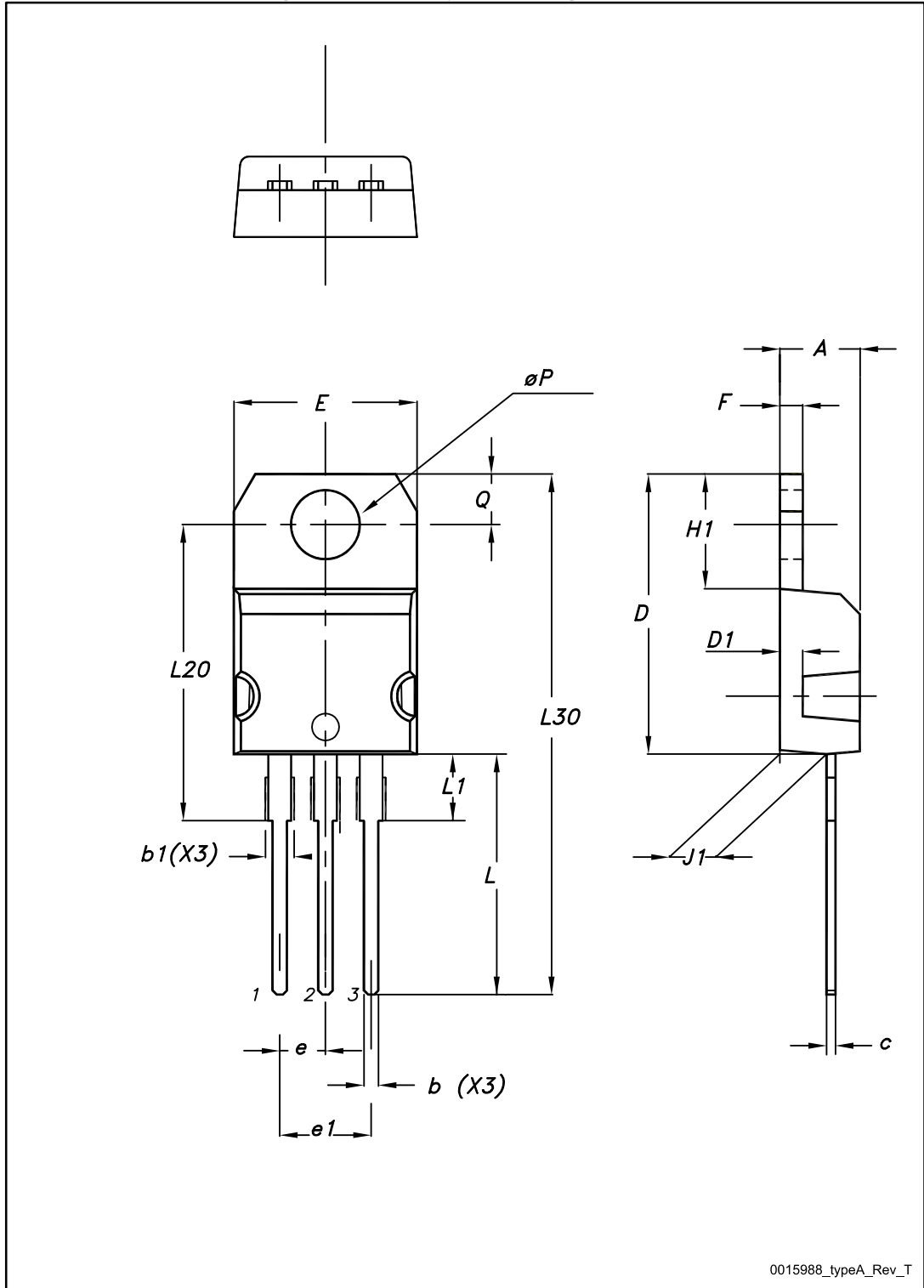

Table 9: TO-220 type A mechanical data

Dim.	mm		
	Min.	Typ.	Max.
A	4.40		4.60
b	0.61		0.88
b1	1.14		1.70
c	0.48		0.70
D	15.25		15.75
D1		1.27	
E	10		10.40
e	2.40		2.70
e1	4.95		5.15
F	1.23		1.32
H1	6.20		6.60
J1	2.40		2.72
L	13		14
L1	3.50		3.93
L20		16.40	
L30		28.90	
ÆP	3.75		3.85
Q	2.65		2.95

## 5 Revision history

Table 10: Document revision history

Date	Revision	Changes
17-Jul-2014	1	First release.
03-Sep-2014	2	Document status promoted from preliminary to production data. Added <i>Section 3.1: "Electrical characteristics (curves)"</i> Minor text changes.
15-Oct-2014	3	Updated <i>Figure 6: "Gate charge vs gate-source voltage"</i> and <i>Figure 8: "Capacitance variations"</i>

**IMPORTANT NOTICE – PLEASE READ CAREFULLY**

STMicroelectronics NV and its subsidiaries ("ST") reserve the right to make changes, corrections, enhancements, modifications, and improvements to ST products and/or to this document at any time without notice. Purchasers should obtain the latest relevant information on ST products before placing orders. ST products are sold pursuant to ST's terms and conditions of sale in place at the time of order acknowledgement.

Purchasers are solely responsible for the choice, selection, and use of ST products and ST assumes no liability for application assistance or the design of Purchasers' products.

No license, express or implied, to any intellectual property right is granted by ST herein.

Resale of ST products with provisions different from the information set forth herein shall void any warranty granted by ST for such product.



ST and the ST logo are trademarks of ST. All other product or service names are the property of their respective owners.

Information in this document supersedes and replaces information previously supplied in any prior versions of this document.

© 2014 STMicroelectronics – All rights reserved

## Looking for pricing, stock, or lifecycle information?

Click below to explore more details on WIN SOURCE:

-  [View STP5N105K5 on WIN SOURCE](#)
-  [STMicroelectronics Information](#)

## Optimize Your Supply Chain with WIN SOURCE Solutions

-  Global Sourcing Solution
-  Obsolete Management
-  Cost Control Management
-  Shortage Management
-  Alternative Solution
-  Excess Inventory Management