



# THE DATASHEET OF SX8658IWLTRT



## ADVANCED COMMUNICATIONS & SENSING

### GENERAL DESCRIPTION

The SX8657 and SX8658 belong to a family of high performance haptics enabled 4/5-wire resistive touch screen controller with proximity detection, optimized for hand held applications such as mobile phones, portable music players, game machines, point-of-sales terminal and other consumer and industrial applications. They feature a wide input supply range from 2.3V to 3.6V.

The controller computes touch screen X-Y coordinates and touch pressure with a precision, low power 12-bit analog-digital converter. On-chip data averaging processing algorithms can be activated to reduce host activity and suppress system noise. The processing core features low power modes which intelligently minimize current in operation as well as in automatic shut-down.

A capacitive proximity detection circuit has been integrated into the SX8657 to enable host controlled power management for battery applications. Proximity detection above 5 cm is possible using either the resistive touch screen as the sensor or with a single conductive plate, with communication to the host via the serial interface.

The SX8657 and SX8658 also integrate a haptics motor driver for Linear Resonant Actuator (LRA) and Eccentric Rotating Mass (ERM) micro motors with up to 250mA drive current. Haptics control can be performed using either an external PWM signal or the I2C serial interface, providing simple host interfacing and minimizing its I/O requirement. The SX8657/58 supports Immersion TouchSense® 3000 haptic control software for high quality touch feedback.

Integrated very high ESD protection, of up to ±15kV on display inputs not only saves cost and board area, but also increases application reliability.

The three devices have an ambient operating temperature range of -40°C to +85°C, and are offered in both a 4mm x 4mm, 20-lead QFN package and 2.07mm x 2.07mm 19-lead CSP package for space-conscious applications.

### TYPICAL APPLICATIONS

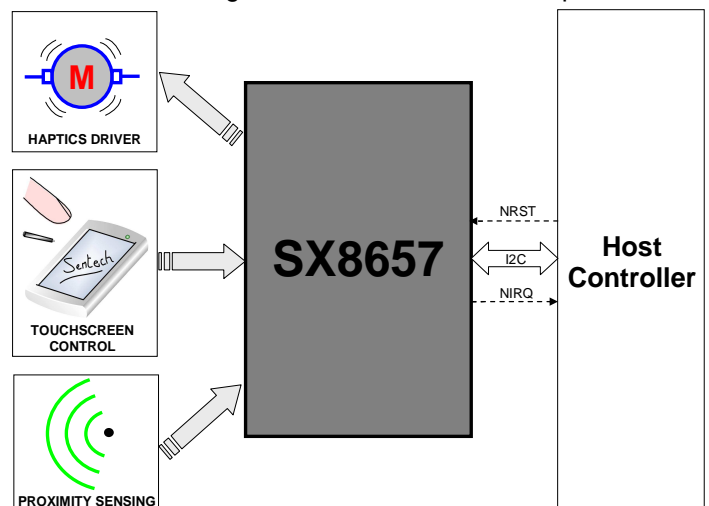
- Game Machines, Portable Music Players
- Mobile Phones
- DSC, DVR, Phones
- POS/POI Terminals
- Touch-Screen Monitors

### ORDERING INFORMATION

Part Number	Package	Marking
SX8657IWLTRT	QFN-20	RD2C
SX8657ICSTRT	WLCSP-19	
SX8658IWLTRT	QFN-20	RC4B
SX8658ICSTRT	WLCSP-19	
SX8654EVK	Evaluation Kit	-

### KEY PRODUCT FEATURES

- Low Voltage Operation
  - 2.3V to 3.6V Supply
  - Integrated Low Drop Out (LDO) Regulator
- Low Power Consumption
  - 30uA@2.3V 8ksp/s (ESR)
  - 0.4uA Shut-Down Current
- 4/5-Wire Touchscreen Interface
  - Precision, Ratiometric 12-bit ADC
  - Up to 5000 (X-Y) coordinates/second (c/s)
  - Programmable Digital Filtering/Averaging
  - Touch Pressure Measurement (4-Wire)
  - Programmable Operating Mode (Manual, Pen Detect, Pen Trigger)
- Capacitive Proximity Sensing (SX8657)
  - No Additional Components Required
  - Uses Resistive Touchscreen or a Simple Conductive Area as the Sensor
  - >5 cm Detection Distance
  - 8uA @ 200ms Scan Period
  - Fully Programmable (Sensitivity, etc)
- Haptics Driver for LRA and ERM (SX8657/58)
  - Supports Immersion TouchSense® 3000 haptic control software
  - Haptics Waveform Generation Control (I2C or PWM Input)
  - Short Circuit Protection
  - Early Warning and Over-Temperature Monitoring and Protection
- 400kHz I2C Serial Interface
- Several Host Operating Modes Available
  - Maskable Interrupt Output (NIRQ)
  - Real-time Events Monitoring (AUX1-3)
  - Polling (I2C)
- Hardware, Software, and Power-On Reset
- -40°C to +85°C Operating Temperature Range
- 15kV HBM & IEC ESD Protection
- Small Footprint Packages
- Pb & Halogen Free, RoHS/WEEE compliant



## Table of Contents

<b>GENERAL DESCRIPTION</b> .....	<b>1</b>
<b>TYPICAL APPLICATIONS</b> .....	<b>1</b>
<b>ORDERING INFORMATION</b> .....	<b>1</b>
<b>KEY PRODUCT FEATURES</b> .....	<b>1</b>
<b>1 GENERAL DESCRIPTION</b> .....	<b>4</b>
<b>1.1 Marking Information</b>	<b>4</b>
1.1.1 SX8657	4
1.1.2 SX8658	4
<b>1.2 Pin Diagrams</b>	<b>5</b>
1.2.1 QFN Package	5
1.2.2 CSP Package	5
<b>1.3 Pin Description</b>	<b>6</b>
<b>1.4 Block Diagram</b>	<b>6</b>
<b>2 ELECTRICAL CHARACTERISTICS</b> .....	<b>8</b>
<b>2.1 Absolute Maximum Ratings</b>	<b>8</b>
<b>2.2 Thermal Characteristics</b>	<b>8</b>
<b>2.3 Electrical Specifications</b>	<b>8</b>
<b>3 TYPICAL OPERATING CHARACTERISTICS</b> .....	<b>11</b>
<b>4 TOUCHSCREEN INTERFACE</b> .....	<b>12</b>
<b>4.1 Introduction</b>	<b>12</b>
<b>4.2 Coordinates Measurement</b>	<b>13</b>
4.2.1 4-wire Touchscreen	13
4.2.2 5-wire Touchscreen	14
<b>4.3 Pressure Measurement (4-wire only)</b>	<b>14</b>
4.3.1 Bias Time (POWDLY)	15
<b>4.4 Pen Detection</b>	<b>15</b>
<b>4.5 Digital Processing</b>	<b>16</b>
<b>4.6 Host Operation</b>	<b>18</b>
4.6.1 Overview	18
4.6.2 Manual Mode (MAN)	18
4.6.3 Pen Detect Mode (PENDET)	19
4.6.4 Pen Trigger Mode (PENTRG)	19
4.6.5 Maximum Throughput vs. TOUCHRATE setting	20
<b>5 PROXIMITY SENSING INTERFACE (SX8657)</b> .....	<b>22</b>
<b>5.1 Introduction</b>	<b>22</b>
<b>5.2 Analog Front-End (AFE)</b>	<b>23</b>
5.2.1 Capacitive Sensing Basics	23
5.2.2 AFE Block Diagram	24
5.2.3 Capacitance-to-Voltage Conversion (C-to-V)	25
5.2.4 Shield Control	25
5.2.5 Offset Compensation	25
5.2.6 Analog-to-Digital Conversion (ADC)	26
<b>5.3 Digital Processing</b>	<b>26</b>
5.3.1 Overview	26
5.3.2 PROXRAW Update	27
5.3.3 PROXUSEFUL Update	28
5.3.4 PROXAVG Update	29
5.3.5 PROXDIFX Update	31

**ADVANCED COMMUNICATIONS & SENSING**

5.3.6	PROXSTAT Update	31
<b>5.4</b>	<b>Host Operation</b>	<b>32</b>
5.4.1	General Description	32
5.4.2	Proximity Sensing vs Touch Operations	32
5.4.3	Minimum Scan Period (i.e. PROXSCANPERIOD)	34
<b>6</b>	<b>HAPTICS INTERFACE (SX8657/58)</b>	<b>35</b>
<b>6.1</b>	<b>Introduction</b>	<b>35</b>
<b>6.2</b>	<b>ERM Load</b>	<b>35</b>
6.2.1	Introduction	35
6.2.2	PWM Mode	36
6.2.3	I2C Mode	36
<b>6.3</b>	<b>LRA Load</b>	<b>36</b>
6.3.1	Introduction	36
6.3.2	PWM Mode	37
6.3.3	I2C Mode	37
<b>6.4</b>	<b>Short-Circuit Protection</b>	<b>37</b>
<b>7</b>	<b>TEMPERATURE SENSOR</b>	<b>38</b>
<b>8</b>	<b>INTERRUPT (NIRQ)</b>	<b>39</b>
<b>8.1</b>	<b>Introduction</b>	<b>39</b>
<b>8.2</b>	<b>Registers Overview</b>	<b>39</b>
8.2.1	RegIrqMsk	39
8.2.2	RegIrqSrc	39
8.2.3	RegStat	39
<b>8.3</b>	<b>Host Procedure</b>	<b>39</b>
<b>9</b>	<b>AUXILIARY PINS (AUX1/AUX2/AUX3)</b>	<b>40</b>
<b>10</b>	<b>RESET</b>	<b>41</b>
10.1	Hardware (POR and NRST)	41
10.2	Software (RegReset)	41
10.3	ESD Event (RESETSTAT)	41
<b>11</b>	<b>I2C INTERFACE</b>	<b>42</b>
11.1	Introduction	42
11.2	I2C Address	42
11.3	Write Register	42
11.4	Read Register	43
11.5	Write Command (Touchscreen Interface)	43
11.6	Read Channel (Touchscreen Interface)	44
<b>12</b>	<b>REGISTERS DETAILED DESCRIPTION</b>	<b>46</b>
<b>13</b>	<b>APPLICATION INFORMATION</b>	<b>58</b>
13.1	Typical Application Circuit	58
13.2	External Components Recommended Values	58
<b>14</b>	<b>PACKAGING INFORMATION</b>	<b>59</b>
14.1	QFN Package	59
14.2	CSP Package	60

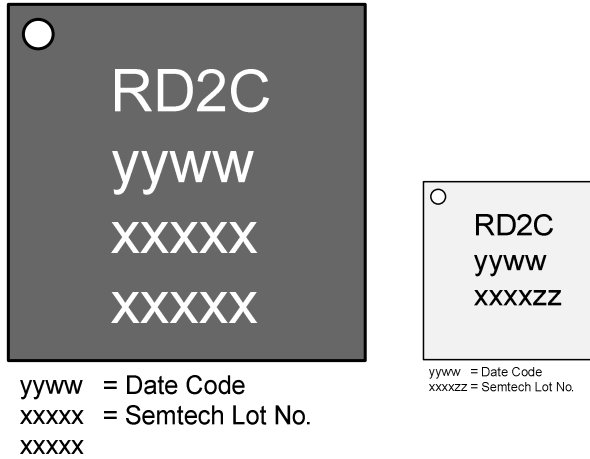
**1 GENERAL DESCRIPTION**
**1.1 Marking Information**
**1.1.1 SX8657**


Figure 1 – Marking Information – QFN(left) – CSP(right)

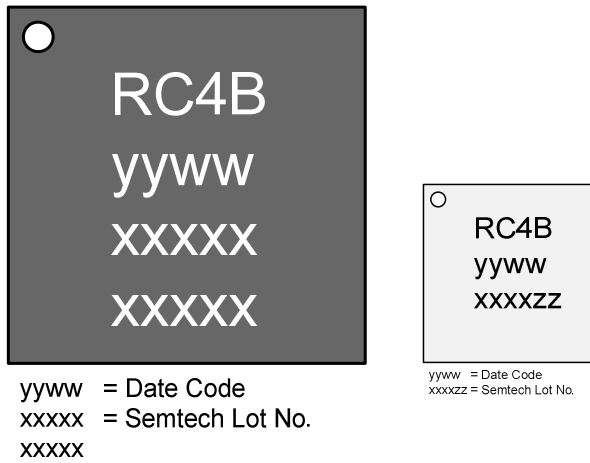
**1.1.2 SX8658**


Figure 2 – Marking Information – QFN(left) – CSP(right)

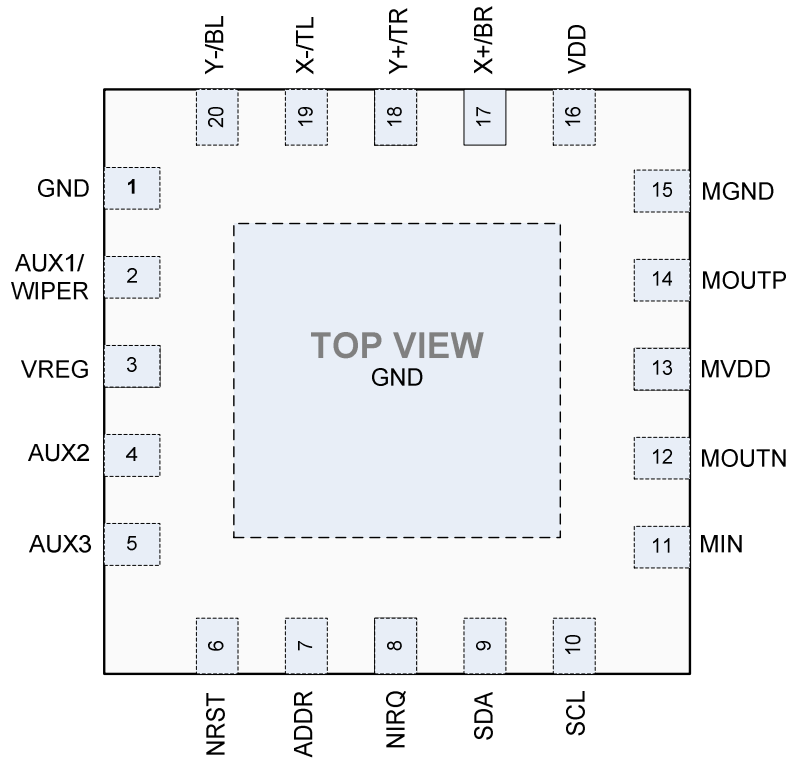
**ADVANCED COMMUNICATIONS & SENSING**
**1.2 Pin Diagrams**
**1.2.1 QFN Package**


Figure 3 – Pin Diagram – QFN

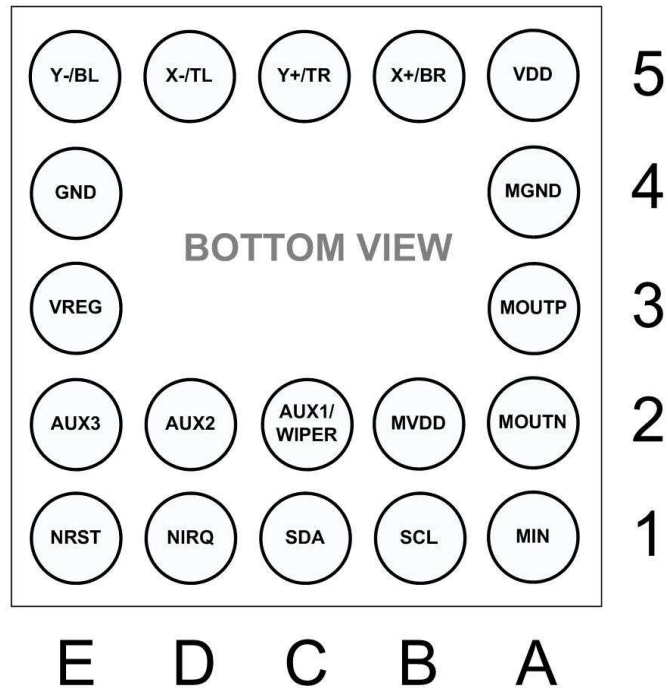
**1.2.2 CSP Package**


Figure 4 – Pin Diagram - CSP

**ADVANCED COMMUNICATIONS & SENSING**
**1.3 Pin Description**

Name	Type	Description
VDD	P	Main Power Supply
GND	P	Main Ground
VREG	P	Internal Regulator Output (must be connected to an external capacitor; see §13)
MVDD	P	Haptics Motor Power Supply
MGND	P	Haptics Motor Ground (must be electrically connected to GND)
MOUTP	AO	Haptics Motor Positive Drive
MOUTN	AO	Haptics Motor Negative Drive
MIN	DI	Haptics Motor PWM/Clock Input
X+/BR	A	<ul style="list-style-type: none"> <li>• 4-wire Touchscreen : X+ Electrode</li> <li>• 5-wire Touchscreen : Bottom Right (BR) Electrode</li> </ul>
Y+/TR	A	<ul style="list-style-type: none"> <li>• 4-wire Touchscreen : Y+ Electrode</li> <li>• 5-wire Touchscreen : Top Right (TR) Electrode</li> </ul>
X-/TL	A	<ul style="list-style-type: none"> <li>• 4-wire Touchscreen : X- Electrode</li> <li>• 5-wire Touchscreen : Top Left (TL) Electrode</li> </ul>
Y-/BL	A	<ul style="list-style-type: none"> <li>• 4-wire Touchscreen : Y- Electrode</li> <li>• 5-wire Touchscreen : Bottom Left (BL) Electrode</li> </ul>
AUX1/WIPER	D/A	<ul style="list-style-type: none"> <li>• 4-wire Touchscreen : First Programmable Auxiliary Function (see §9)</li> <li>• 5-wire Touchscreen : WIPER Electrode</li> </ul>
AUX2	D/A	Second Programmable Auxiliary Function (see §9)
AUX3	D/A	Third Programmable Auxiliary Function (see §9)
ADDR	DI	I2C Address Selection (QFN only, internally connected to GND on CSP)
SCL	DI	I2C Clock Input
SDA	DIO	I2C Data Input/Output
NIRQ	DO	Interrupt Output (active low)
NRST	DI	Reset Input (active low)

A/D/I/O/P: Analog/Digital/Power/Input/Output

Table 1 – Pin Description

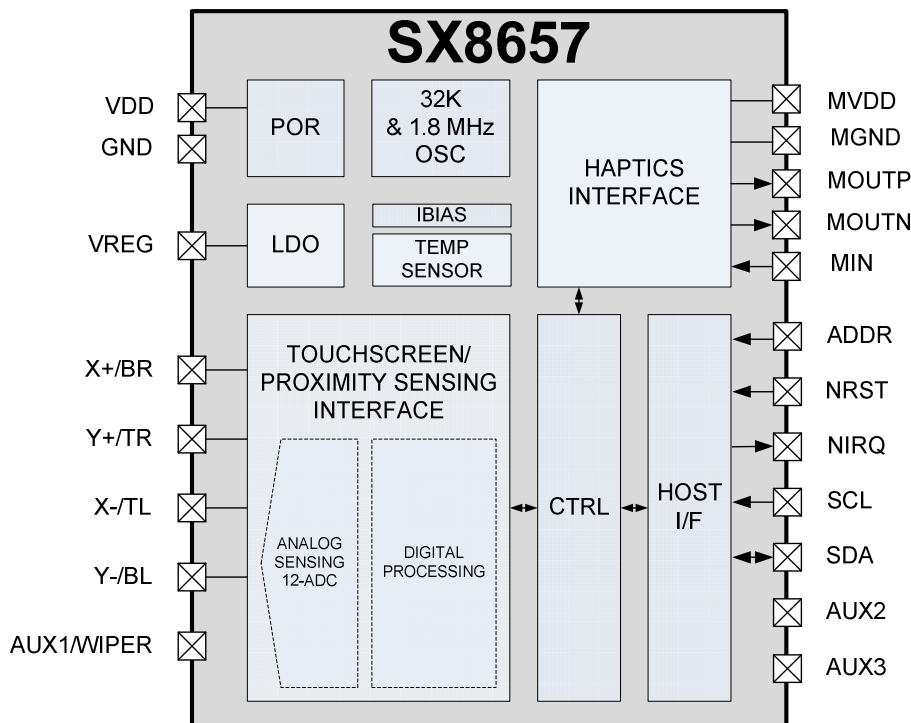
**1.4 Block Diagram**


Figure 5 – SX8657 Block Diagram

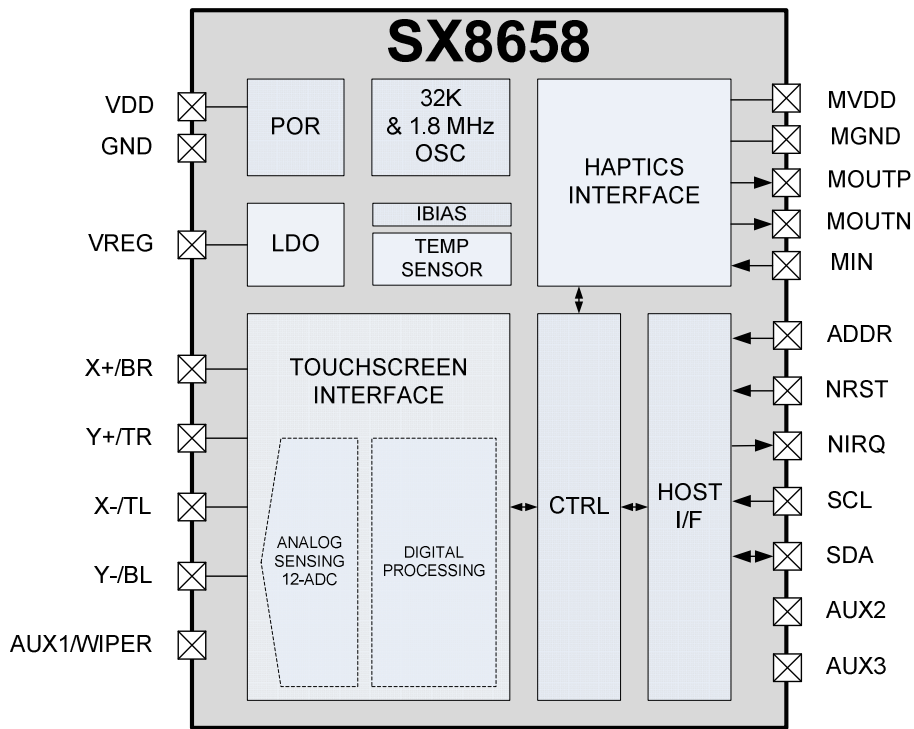


Figure 6 – SX8658 Block Diagram

**ADVANCED COMMUNICATIONS & SENSING**
**2 ELECTRICAL CHARACTERISTICS**
**2.1 Absolute Maximum Ratings**

Stress above the limits listed in the following table may cause permanent failure. Exposure to absolute ratings for extended time periods may affect device reliability. The limiting values are in accordance with the Absolute Maximum Rating System (IEC 134). All voltages are referenced to ground (GND).

Symbol	Description	Conditions	Min	Max	Unit
VABS	Voltage applied on any pin		- 0.5	3.9	V
VESDHBM	Electrostatic handling Human Body Model (HBM)	X+/BR, Y+/TR, X-/TL, Y-/BL, VDD, MVDD	+/-15 <sup>(1)</sup> , +/-8 <sup>(2)</sup>		kV
		Other pins	+/-8 <sup>(2)</sup>		
VESDCDM	Electrostatic handling Charged Device Model (CDM)	X+/BR, Y+/TR, X-/TL, Y-/BL, VDD, MVDD	+/-1		kV
		Other pins	+/-1		
VESDMM	Electrostatic handling Machine Model (MM)	X+/BR, Y+/TR, X-/TL, Y-/BL, VDD, MVDD	+/-250		V
		Other pins	+/-250		
VESDCD	Electrostatic handling Contact Discharge (CD)	X+/BR, Y+/TR, X-/TL, Y-/BL, VDD, MVDD	+/-15		kV
TAMB	Operating ambient temperature		-40	+85	°C
TJUN	Operating junction temperature		-40	+125	°C
TSTOR	Storage temperature		-55	+150	°C
ILAT	Latch-up current <sup>(3)</sup>		+/-100		mA

(1) Tested to TLP (10A)

(2) Tested to JEDEC standard JESD22-A114

(3) Tested to JEDEC standard JESD78

Table 2 - Absolute Maximum Ratings

**2.2 Thermal Characteristics**

Symbol	Description	Conditions	Min	Max	Unit
$\theta_{JAQ}$	Thermal Resistance Junction – Ambient QFN package	-	-	30.5	°C/W
$\theta_{JAW}$	Thermal Resistance Junction – Ambient WLCSP package	-	-	29	°C/W

Table 3 – Thermal Characteristics

**2.3 Electrical Specifications**

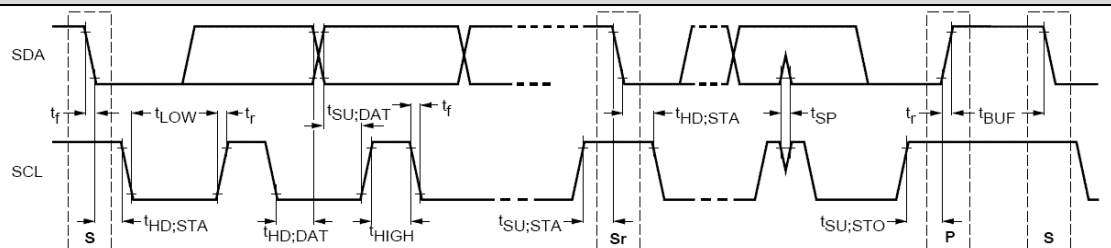
Table below applies to full supply voltage and temperature range, unless otherwise specified. Typical values are given for  $T_A = +25^\circ\text{C}$ ,  $VDD = VDDM = 3.3V$ .

Symbol	Description	Conditions	Min	Typ.	Max	Unit
<b>Supply</b>						
VDD	Main supply voltage	-	2.3	-	3.6	V
IDD	Main supply current	OFF (MAN mode, no command, HAPT OFF)	-	0.4	0.75	uA
		WAIT (PENDET/TRG mode, pen up, PROX OFF, HAPT OFF)	-	1.7	-	
		TOUCH1 (PENTRG mode, pen down, X+Y, RATE=4kcps, Nfilt=1, POWDLY=0.5us, touchscreen current excluded, HAPT OFF, VDD=2.3V)	-	30	-	
		TOUCH2 (PENTRG mode, pen down, X+Y, RATE=3kcps, Nfilt=7, POWDLY=0.5us, touchscreen current excluded, HAPT OFF)	-	120	160	

**ADVANCED COMMUNICATIONS & SENSING**

Symbol	Description	Conditions	Min	Typ.	Max	Unit
		PROX (PENDET/TRG mode, pen up, TOUCHRATE=80cps, PROX ON, SCANPERIOD=200ms, HIGHIM=ON, SENSITIVITY=Max, FREQ=150kHz, BOOST=OFF, HAPT OFF)	-	8	20	
		HAPT (MAN mode, no command, LRA-PWM mode, MIN= 44.8kHz/50%, GAIN = Max, BW = 100, MOUTP/N floating, Squelch=011)	-	115	145	
MVDD	Haptics supply voltage	-	VDD	-	3.6	V
		OFF	-	0.01	1	µA
MIDD	Haptics supply current	SQUELCH (LRA-PWM mode, MIN= 44.8kHz/50%, GAIN = Max, BW = 100, MOUTP/N floating, Squelch=011)	-	6	10	µA
<b>Digital I/Os (ADDR, SCL, SDA, NRST, NIRQ, AUX1, AUX2, AUX3, MIN)</b>						
VIH	High level input voltage	SCL, SDA, NRST	0.8*VDD	-	3.6	V
		Other pins	0.8*VDD	-	VDD+0.2	
VIL	Low level input voltage	-	-0.3	-	0.8	V
ILEAK	Input leakage current	-	-1	-	1	µA
CI	Input capacitance	-	-	5	-	pF
VOH	High level output voltage	IOH = 4mA	0.8*VDD	-	-	V
VOL	Low level output voltage	IOL = 4mA	-	-	0.4	V
VPULL	External pull-up voltage	SCL, SDA, NRST, NIRQ	-	-	3.6	V
<b>Haptics Interface</b>						
IDRV	Maximum drive current (MOUTP/MOUTN)	MVDD = 3.6V	-	250	-	mA
VOFF	Output squelch differential error (from 0V ideal)	LRA or ERM, PWM or I2C, AmplitudeCode within squelch range, GAIN = Max, BW = 100, MOUTP/N floating, Squelch=011	0 <sup>(1)</sup>	0	0 <sup>(1)</sup>	mV
VERR	Output differential error (from 1.135V ideal)	LRA or ERM, I2C, AmplitudeCode = +127 (Max) GAIN = Min, BW = 100, MOUTP/N floating	125 <sup>(2)</sup>	0	125 <sup>(2)</sup>	mV
VDRV	Drive voltage (MOUTP/MOUTN)	-	-	-	VDDM	V
VDROP	Drop voltage (MOUTP/MOUTN)	From MVDD/MGND, @250mA	-	-	150	mV
ISHORT	Short-circuit detection current	Measured @MIDD	-	300	-	mA
FMINC	Motor input (MIN) frequency in I2C mode	40-60% duty cycle	-	-	50	MHz
FMINP	Motor input (MIN) frequency in PWM mode	HAPTRANGE = 0	12.8	-	25.6	kHz
		HAPTRANGE = 1	25.6	-	51.2	kHz
DCMIN	Motor input (MIN) duty cycle in PWM mode		2	-	98	%
TWRNG	Warning temperature	Junction temperature	-	120	-	°C
TALRM	Alarm temperature		-	155	-	
<b>Touchscreen Interface</b>						
ARES	ADC resolution		12	-	-	bits
AOFF	ADC offset		-	± 1	-	
AGE	ADC gain error	At full scale	-	0.5	-	LSB
ADNL	ADC differential non-linearity		-	± 1	-	
AINL	ADC integral non-linearity		-	± 1.5	-	
RBIAS	Biasing resistance		-	5	-	Ω
<b>Proximity Sensing Interface</b>						
CDC	External capacitance to be compensated	-	-	-	300	pF
t <sub>PROX</sub>	Scan period (reaction time)	Programmable	-	200	-	ms

**ADVANCED COMMUNICATIONS & SENSING**

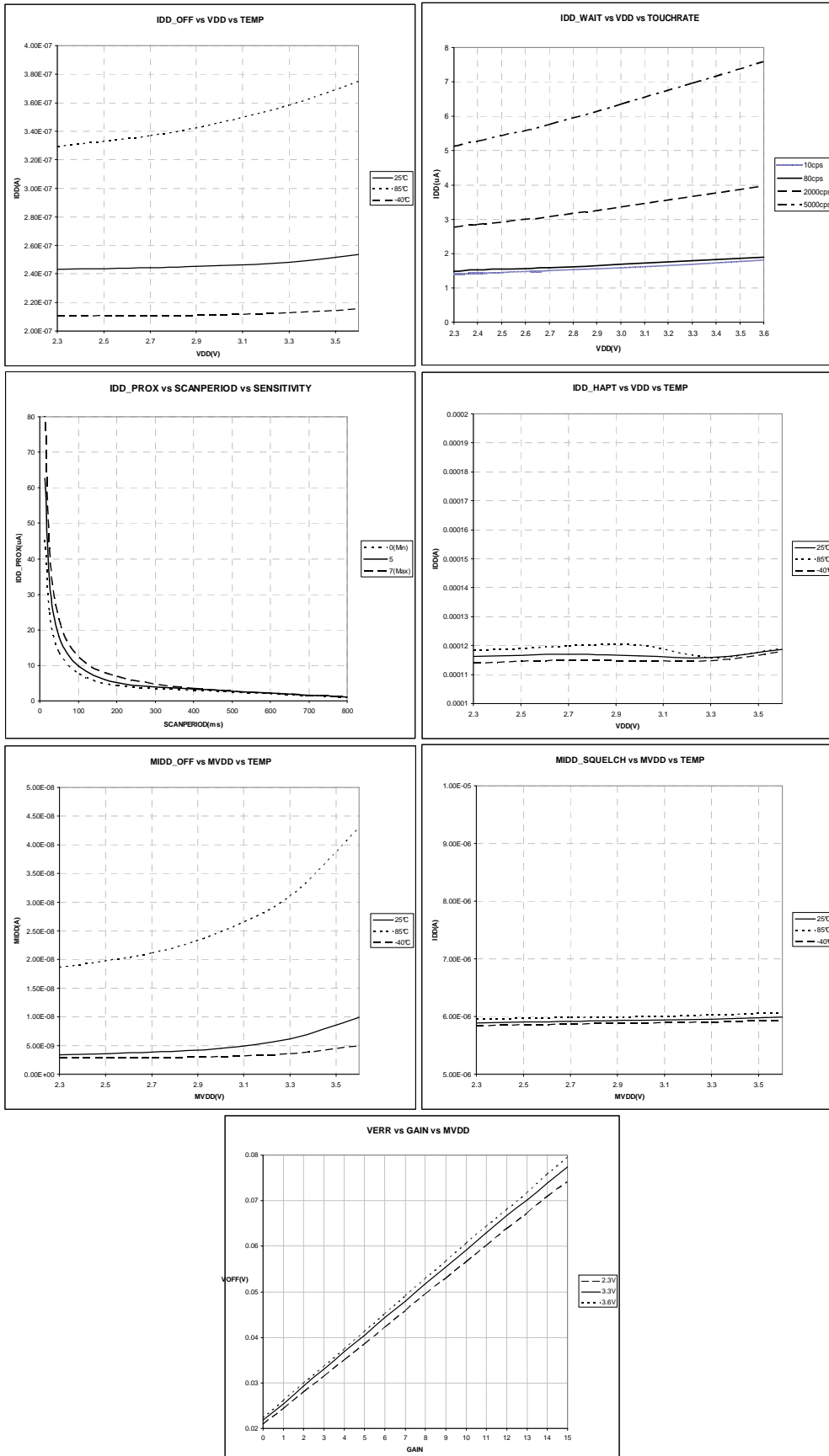
Symbol	Description	Conditions	Min	Typ.	Max	Unit
<b>Reset</b>						
VPOR	Power-On-Reset voltage	Cf. §10	-	1.3	-	V
$t_{\text{RESET}}$	Reset time after POR	Cf. §10	-	-	1	ms
$t_{\text{PULSE}}$	Reset pulse from host uC	Cf. §10	1	-	-	us
<b>I2C Interface</b>						
 <p>The diagram shows the timing relationship between SDA and SCL signals. It illustrates a sequence of START (s), repeated START (Sr), and STOP (P) conditions. Key timing parameters are labeled: <math>t_{\text{HD:STA}}</math> (hold time for repeated START), <math>t_{\text{LOW}}</math> (LOW period of SCL), <math>t_{\text{HIGH}}</math> (HIGH period of SCL), <math>t_{\text{SU:STA}}</math> (set-up time for repeated START), <math>t_{\text{HD:DAT}}</math> (data hold time), <math>t_{\text{SU:DAT}}</math> (data set-up time), <math>t_r</math> (rise time of both SDA and SCL), <math>t_f</math> (fall time of both SDA and SCL), <math>t_{\text{SU:STO}}</math> (set-up time for STOP), <math>t_{\text{BUF}}</math> (bus free time between STOP and START), and <math>t_{\text{SP}}</math> (pulse width of spikes suppressed by the input filter). The diagram also shows a capacitive load <math>C_b</math> on the bus lines.</p>						
$f_{\text{SCL}}$	SCL clock frequency	-	-	-	400	kHz
$t_{\text{HD:STA}}$	Hold time (repeated) START condition	-	0.6	-	-	$\mu\text{s}$
$t_{\text{LOW}}$	LOW period of the SCL clock	-	1.3	-	-	$\mu\text{s}$
$t_{\text{HIGH}}$	HIGH period of the SCL clock	-	0.6	-	-	$\mu\text{s}$
$t_{\text{SU:STA}}$	Set-up time for a repeated START condition	-	0.6	-	-	$\mu\text{s}$
$t_{\text{HD:DAT}}$	Data hold time	-	0	-	-	$\mu\text{s}$
$t_{\text{SU:DAT}}$	Data set-up time	-	100	-	-	ns
$t_r$	Rise time of both SDA and SCL	-	$20+0.1C_b$	-	300	ns
$t_f$	Fall time of both SDA and SCL	-	$20+0.1C_b$	-	300	ns
$t_{\text{SU:STO}}$	Set-up time for STOP condition	-	0.6	-	-	$\mu\text{s}$
$t_{\text{BUF}}$	Bus free time between a STOP and START condition	-	1.3	-	-	$\mu\text{s}$
$C_b$	Capacitive load for each bus line	-	-	-	400	pF
$t_{\text{SP}}$	Pulse width of spikes suppressed by the input filter	Up to 0.3xVDD from GND, down to 0.7xVDD from VDD	50	-	-	ns
<b>Miscellaneous</b>						
FOSCL	Low frequency internal oscillator	-	-	32	-	kHz
FOSCH	High frequency internal oscillator	-	-	1.8	-	MHz

<sup>(1)</sup> Guaranteed by design.

<sup>(2)</sup> PWM mode can introduce an additional error of 2.5% of full scale.

Table 4 – Electrical Specifications

**3 TYPICAL OPERATING CHARACTERISTICS**

 Conditions as defined in §2.3,  $T_A = +25^\circ\text{C}$ ,  $V_{DD} = V_{DDM} = 3.3\text{V}$  unless otherwise specified.


**ADVANCED COMMUNICATIONS & SENSING**
**4 TOUCHSCREEN INTERFACE**
**4.1 Introduction**

The purpose of the touchscreen interface is to measure and extract touch information like coordinates and pressure. This is done in two steps, first an ADC measures the analog signal coming from the screen, and then digital processing is performed to consolidate the data.

As illustrated below the chip's touchscreen interface is compatible with both 4-wire and 5-wire touchscreens. Touchscreen type is defined by parameter TSTYPE.

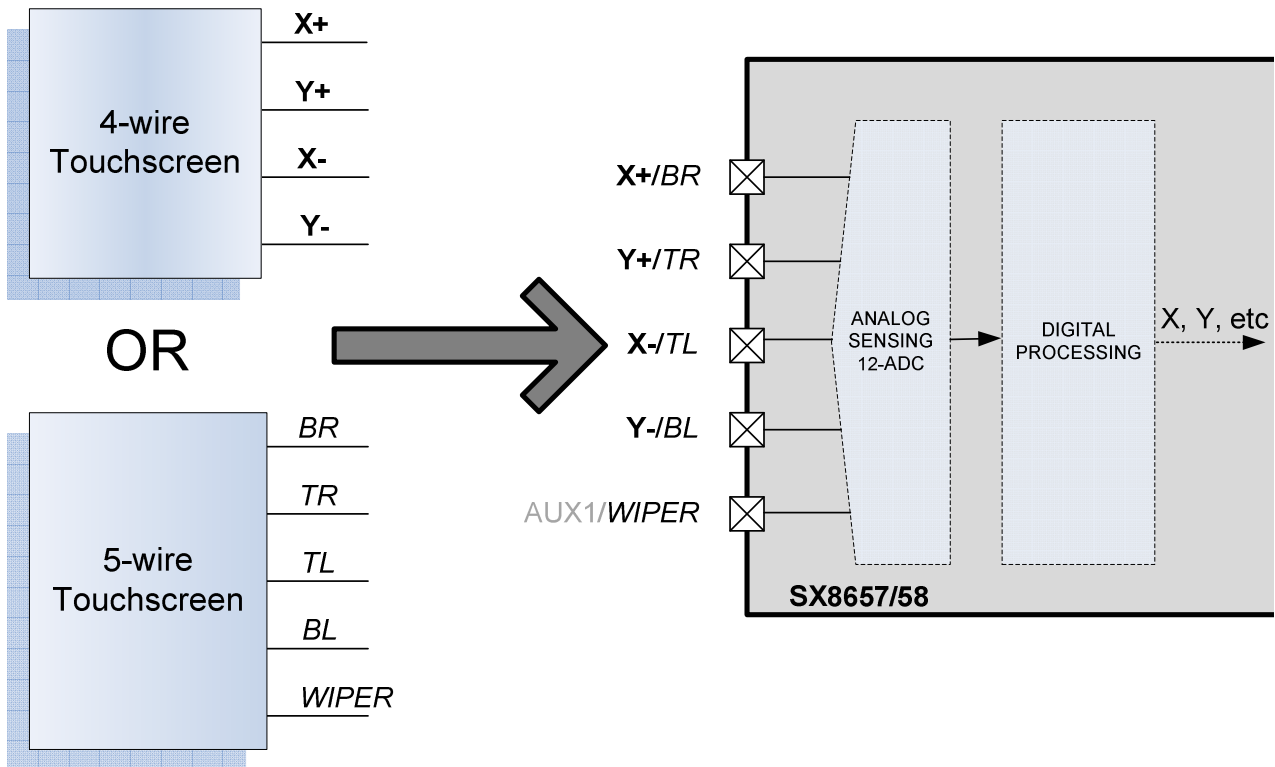


Figure 7 – Touchscreen Interface Overview

A 4-wire resistive touch screen consists in two (resistive) conductive sheets separated by an insulator when not pressed. Each sheet is connected through 2 electrodes at the border of the sheet. When a pressure is applied on the top sheet, a connection with the lower sheet is established.

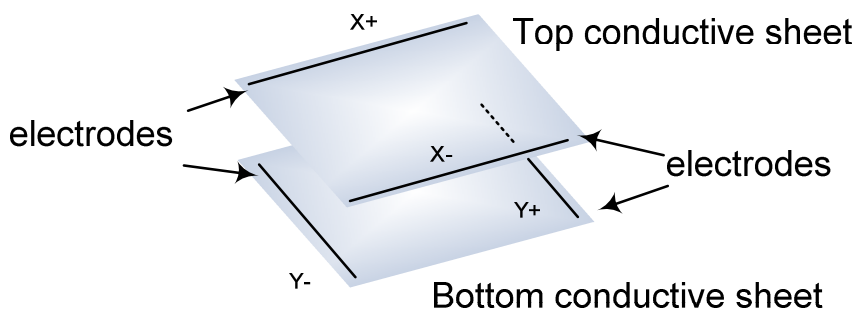


Figure 8 – 4-wire Touchscreen

A 5-wire resistive touch screen consists in two (resistive) conductive sheets separated by an insulator when not pressed. 4 electrodes are connected on the 4 corners of the bottom conductive sheet. They are referred as Top Left (TL), Top Right (TR), Bottom Left (BL) and Bottom Right (BR).

The fifth wire (WIPER) is used for sensing the top sheet voltage. When a pressure is applied on the top sheet, a connection with the lower sheet is established.

**ADVANCED COMMUNICATIONS & SENSING**

Higher reliability and better endurance are the advantages of 5-wire touchscreens but they do not allow pressure measurement

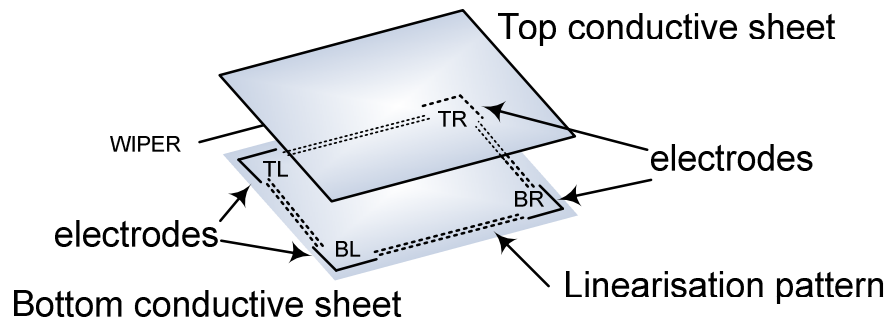


Figure 9 – 5-wire Touchscreen

## 4.2 Coordinates Measurement

### 4.2.1 4-wire Touchscreen

The electrode plates are internally connected through terminals X+, X- and Y+, Y- to an analog to digital converter (ADC) and a reference voltage (Vref). The resistance between the terminals X+ and X- is defined by Rxtot. Rxtot will be split in 2 resistors, R1 and R2, in case the screen is touched. Similarly, the resistance between the terminals Y+ and Y- is represented by R3 and R4. The connection between the top and bottom sheet is represented by the touch resistance (RT).

In order to measure the Y coordinate, the top resistive sheet (Y) is biased with a voltage source (Vref). Resistors R3 and R4 determine a voltage divider proportional to the Y position of the contact point. Since the converter has a high input impedance, no current flows through R1 (and RT) so that the voltage X+ at the converter input is given by the voltage divider created by R3 and R4.

The X coordinate is measured in a similar fashion with the bottom resistive sheet (X) biased to create a voltage divider by R1 and R2, while the voltage on the top sheet is measured through R3.

The resistance RT is the resistance obtained when a pressure is applied on the screen. RT is created by the contact area of the X and Y resistive sheet and varies with the applied pressure.

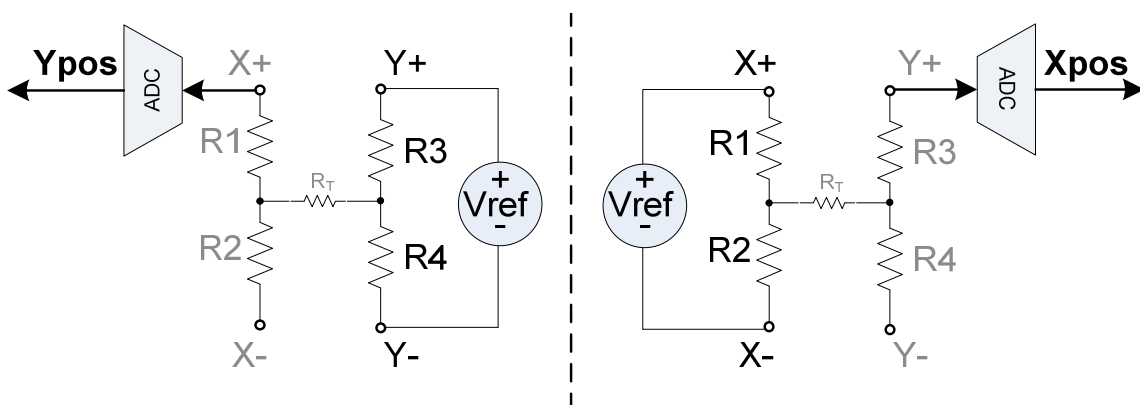


Figure 10 – 4-wire Touchscreen Coordinates Measurement

The X and Y positions output by the ADC correspond to the formulas below:

$$X_{pos} = 4095 \cdot \frac{R2}{R1 + R2} \quad Y_{pos} = 4095 \cdot \frac{R4}{R3 + R4}$$

4095 corresponds to the max output value of the ADC (12 bits =>  $2^{12} - 1$ ).

For example, a touch in the center of the screen will output  $(X_{pos}, Y_{pos}) = \sim(2048, 2048)$

**ADVANCED COMMUNICATIONS & SENSING**
**4.2.2 5-wire Touchscreen**

5-wire touchscreen coordinates measurement is performed similarly by biasing opposite corner pairs in either X or Y directions on the lower panel, and converting the voltage appearing on the wiper panel with the ADC.

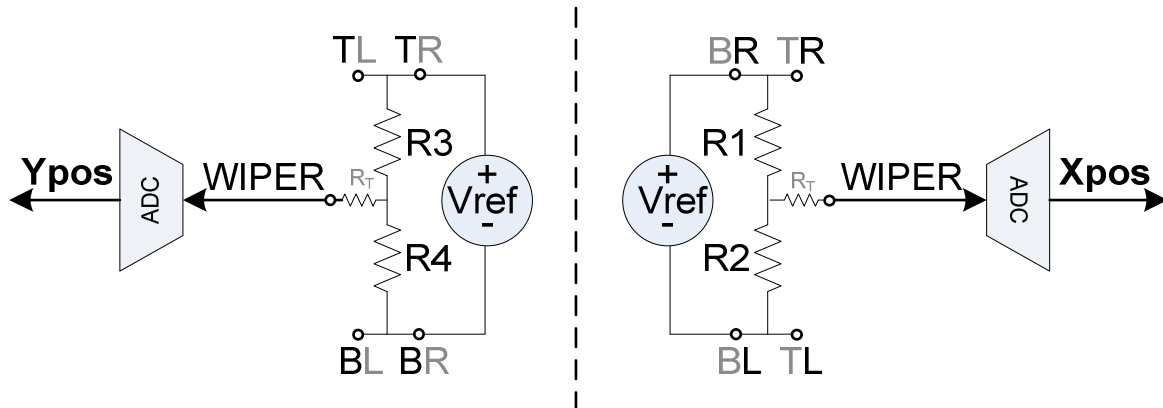


Figure 11 – 5-wire Touchscreen Coordinates Measurement

The X and Y positions output by the ADC correspond to the formulas below:

$$X_{pos} = 4095 \cdot \frac{R_2}{R_1 + R_2} \quad Y_{pos} = 4095 \cdot \frac{R_4}{R_3 + R_4}$$

4095 corresponds to the max output value of the ADC (12 bits =>  $2^{12} - 1$ ).

For example, a touch in the center of the screen will output  $(X_{pos}, Y_{pos}) = \sim(2048, 2048)$

**4.3 Pressure Measurement (4-wire only)**

The pressure measurement consists in extracting the touch resistance  $R_T$  via two additional setups  $z_1$  and  $z_2$  illustrated below. The smaller  $R_T$ , the more common touched surface there is between top and bottom plates and hence the more “pressure” there is by the user.

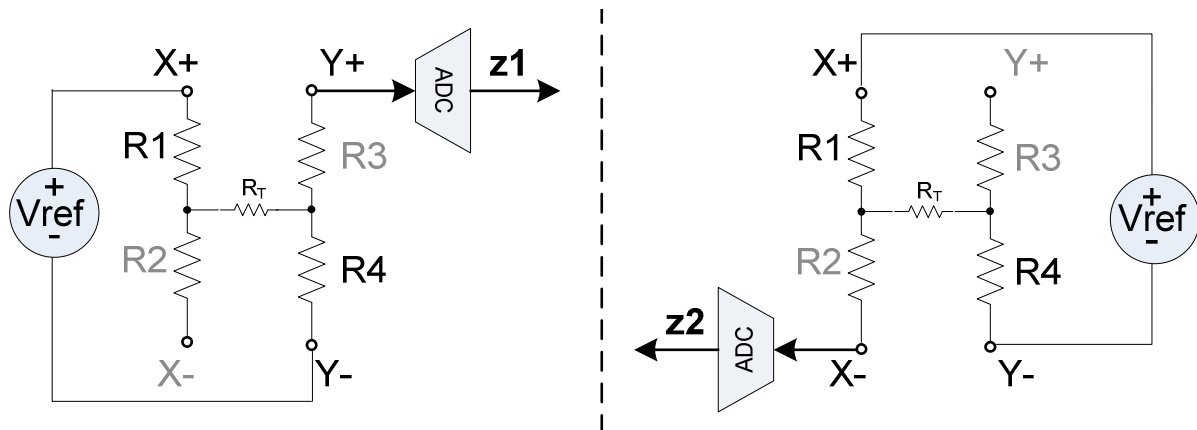


Figure 12 – Pressure Measurement

The  $z_1$  and  $z_2$  values output by the ADC correspond to the formulas below:

$$z_1 = 4095 \cdot \frac{R_4}{R_1 + R_4 + R_T} \quad z_2 = 4095 \cdot \frac{R_4 + R_T}{R_1 + R_4 + R_T}$$

The X and Y total sheet resistance ( $R_{xtot} = R_1 + R_2$ ,  $R_{ytot} = R_3 + R_4$ ) are known from the touch screen supplier.

$R_4$  is proportional to the Y coordinate and its value is given by the total Y plate resistance  $R_{ytot}$  multiplied by the fraction of the Y position over the full coordinate range.

**ADVANCED COMMUNICATIONS & SENSING**

$$R_{xtot} = R1 + R2$$

$$R_{ytot} = R3 + R4$$

$$R4 = R_{ytot} \cdot \frac{Y_{pos}}{4095}$$

Re-arranging z1 and z2 gives:

$$R_T = R4 \cdot \left[ \frac{z2}{z1} - 1 \right]$$

This finally results in:

$$R_T = R_{ytot} \cdot \frac{Y_{pos}}{4095} \cdot \left[ \frac{z2}{z1} - 1 \right]$$

The touch resistance calculation above hence requires three channel measurements ( $Y_{pos}$ ,  $z2$  and  $z1$ ) and one specification data ( $R_{ytot}$ ).

An alternative calculation method is using  $X_{pos}$ ,  $Y_{pos}$ , one z channel and both  $R_{xtot}$  and  $R_{ytot}$  as shown in the next calculations.

$R1$  is inversely proportional to the X coordinate:

$$R1 = R_{xtot} \cdot \left[ 1 - \frac{X_{pos}}{4095} \right]$$

Substituting  $R1$  and  $R4$  into  $z1$  and rearranging terms gives:

$$R_T = \frac{R_{ytot} \cdot Y_{pos}}{4095} \cdot \left[ \frac{4095}{z1} - 1 \right] - R_{xtot} \cdot \left[ 1 - \frac{X_{pos}}{4095} \right]$$

Please note that the chip only outputs  $z1$ ,  $z2$ , etc. The calculation of  $R_T$  itself with the formulas above must be performed by the host.

#### 4.3.1 Bias Time (POWDLY)

In order to perform correct measurements, some time must be given for the touch screen to reach a proper  $V_{ref}$  bias level before the conversion is actually performed. It is a function of the PCB trace resistance connecting the chip to the touchscreen and also the capacitance of the touchscreen. If  $\tau$  is this RC time constant, then POWDLY duration must be programmed to 10  $\tau$  to reach 12 bits accuracy.

Adding a capacitor from the touch screen electrodes to ground may also be used to minimize external noise (if the touchscreen is used as the proximity sensor, make sure you do not exceed the maximum capacitive load for required for proper proximity sensing operation). The low-pass filter created with the capacitor may increase settling time requirement. Therefore, POWDLY can be used to stretch the acquisition period and delay conversion appropriately.

POWDLY can be estimated by the following formula:

$$PowDly = 10 \times R_{touch} \times C_{touch}$$

#### 4.4 Pen Detection

The pen detection circuitry is used both to detect a user action and generate an interrupt or start an acquisition in PENDET and PENTRG mode respectively. Doing pen detection prior to conversion avoids feeding the host with dummy data and saves power. Pen detection is also used to disable and resume proximity sensing. For more details on pen detection usage please refer to §4.6.

A 4-wire touchscreen will be powered between  $X+$  and  $Y-$  through a resistor  $RPNDT$  so no current will flow as long as no pressure is applied to the surface (see figure below). When a touch occurs, a current path is created bringing  $X+$  to the level defined by the resistive divider determined by  $RPNDT$  and the sum of  $R1$ ,  $R_T$  and  $R4$ .

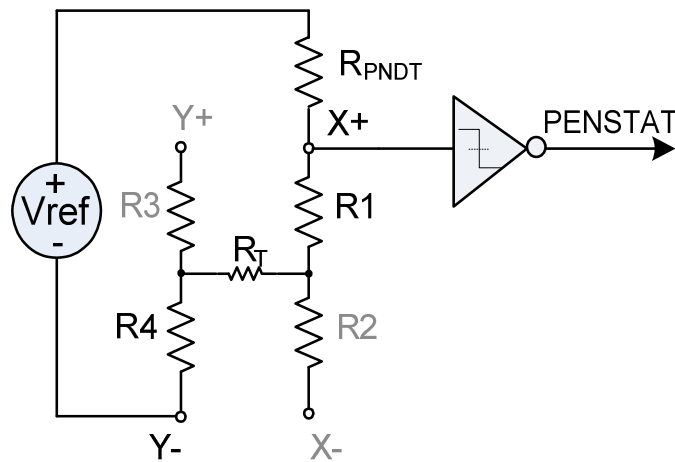


Figure 13 – 4-wire Touchscreen Pen Detection

When using a 5-wire touchscreen, the pen detection pull-up resistor  $R_{PNDT}$  and digital comparator continue to monitor the X+/BR pin as in 4-wire mode. The top panel is grounded via the WIPER pin to provide the grounding path for a screen touch event. When a touch occurs, a current path is created and will bring BR to the level defined by the resistive divider determined by  $R_{PNDT}$  and the sum of  $R_1$ ,  $R_T$  and  $R_W$ .

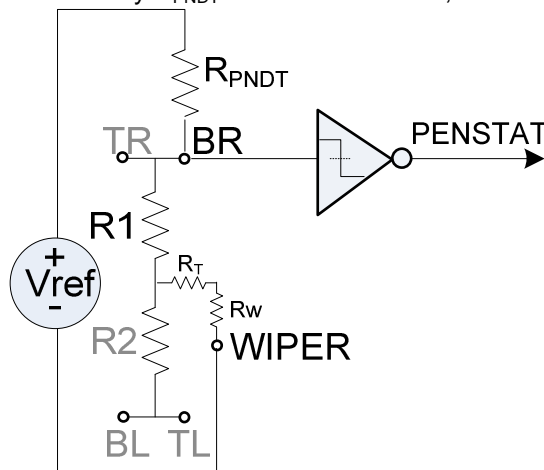


Figure 14 – 5-wire Touchscreen Pen Detection

$R_{PNDT}$  can be configured to 4 different values to accommodate different screen resistive values.  $R_{PNDT}$  should be set to a value greater than  $7 \times (R_{xtot} + R_{ytot})$ , it is recommended to set it to max value.

Pen detection uses a bias time of  $POWDLY/8$  (digital comparator => less precision required vs analog conversion). Increasing  $POWDLY$  can improve the detection on panels with high resistance.

A pen touch will set the PENSTAT bit of the RegStat register which will generate an interrupt if enabled in RegIrqMsk.

A pen release will reset PENSTAT bit of the RegStat register which will generate an interrupt if enabled in RegIrqMsk.

#### 4.5 Digital Processing

The chip offers 4 types of data processing which allows the user to make trade-offs between data throughput, power consumption and noise rejection.

The parameter  $FILT$  is used to select the filter order  $N_{filt}$ . The noise rejection will be improved with a high order to the detriment of power consumption. Each channel can be sampled up to 7 times and then processed to get a single consolidated coordinate.

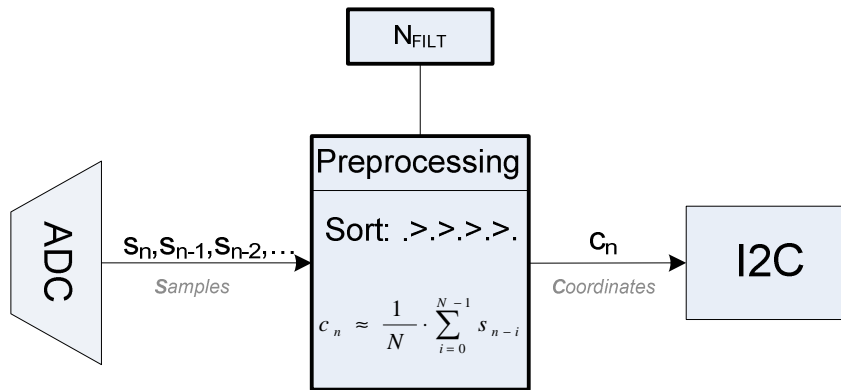
**ADVANCED COMMUNICATIONS & SENSING**


Figure 15 – Digital Processing Block Diagram

FILT	Nfilt	Function
0	1	$c_n = s_n$ No average.
1	3	$c_n = \frac{1}{3} \cdot \frac{4079}{4095} (s_n + s_{n-1} + s_{n-2})$ 3 ADC samples are averaged.
2	5	$c_n = \frac{1}{5} \cdot \frac{4079}{4095} (s_n + s_{n-1} + s_{n-2} + s_{n-3} + s_{n-4})$ 5 ADC samples are averaged.
3	7	$s_{\max 1} \geq s_{\max 2} \geq s_a \geq s_b \geq s_c \geq s_{\min 1} \geq s_{\min 2}$ $c_n = \frac{1}{3} \cdot \frac{4079}{4095} (s_a + s_b + s_c)$ 7 ADC samples are sorted and the 3 center samples are averaged.

Table 5 – Digital Processing Functions

The parameter SETDLY sets the settling time between the consecutive conversions of the same channel.

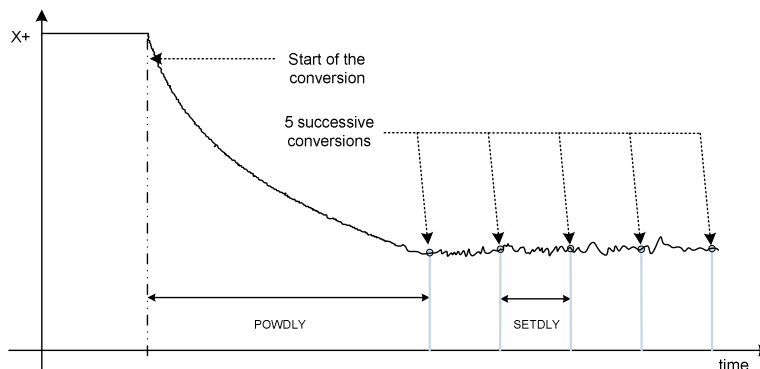


Figure 16 – POWDLY and SETDLY (FILT=2)

In most applications, SETDLY can be set to minimum (0.5us). However, in some particular applications where an accuracy of 1LSB is required SETDLY may need to be increased.

**ADVANCED COMMUNICATIONS & SENSING**
**4.6 Host Operation**
**4.6.1 Overview**

The chip has three operating modes that are configured using the I2C as defined in §11 :

- Manual (command 'MAN' and TOUCHRATE = 0).
- Pen detect (command 'PENDET' and TOUCHRATE > 0).
- Pen trigger (command 'PENTRG' and TOUCHRATE > 0).

At power-up the chip is set in manual mode.

**4.6.2 Manual Mode (MAN)**

In manual mode (MAN) the touchscreen interface is stopped and conversions must be manually triggered by the host using SELECT and CONVERT command.

When a command is received, the chip executes the associated tasks listed in table below and waits for the next command. It is up to the host to sequence all actions.

Pen detection is performed after each CONVERT command and if pen is not detected, no touch operation is performed. Following figures assume pen down. PENSTAT is not updated in MAN mode.

To enter MAN mode the host must send the MAN command and then set TOUCHRATE = 0.

Command	Actions
CONVERT(CHAN)	Select and bias CHAN Wait for the programmed settling time (POWDLY) Convert CHAN
SELECT(CHAN)	Select and bias CHAN

Table 6 – Manual Mode Commands

As illustrated in figure below the CONVERT command will bias the channel, wait for the programmed settling time (POWDLY), and run the conversion.

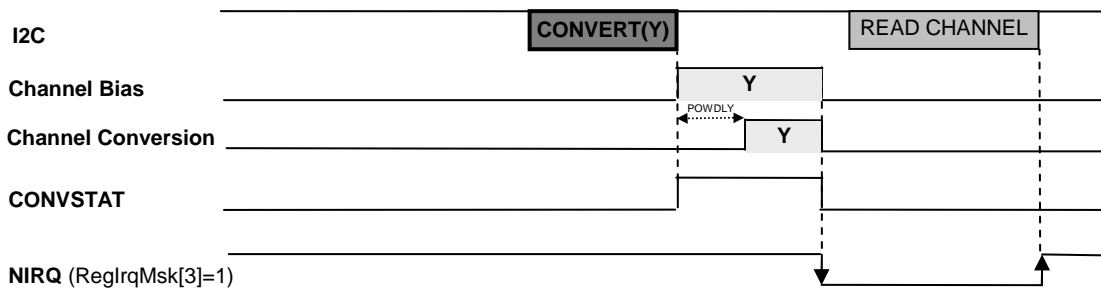


Figure 17 – Manual Mode – CONVERT Command (CHAN = Y; PROXSCANPERIOD = 0)

When the CONVERT command is used with CHAN=SEQ, multiple channels as defined in RegChnMsk are sampled. In this case, each channel will be sequentially biased during POWDLY before a conversion is started. At the end of each channel conversion the bias is automatically removed.

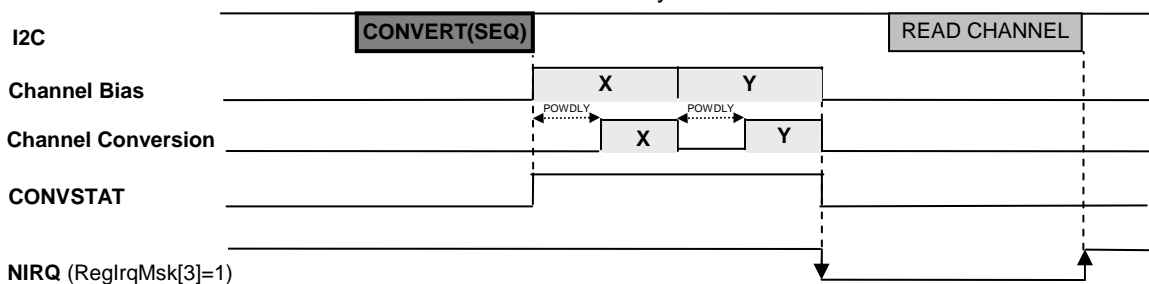


Figure 18 – Manual Mode – CONVERT Command (CHAN = SEQ = [X; Y]; PROXSCANPERIOD = 0)

**ADVANCED COMMUNICATIONS & SENSING**

In case the range of POWDLY settings available is not enough to cover the required settling time, one can use the SELECT command first to bias the channel, and then send the CONVERT command hence extending bias time. SELECT command cannot be used with CHAN=SEQ.

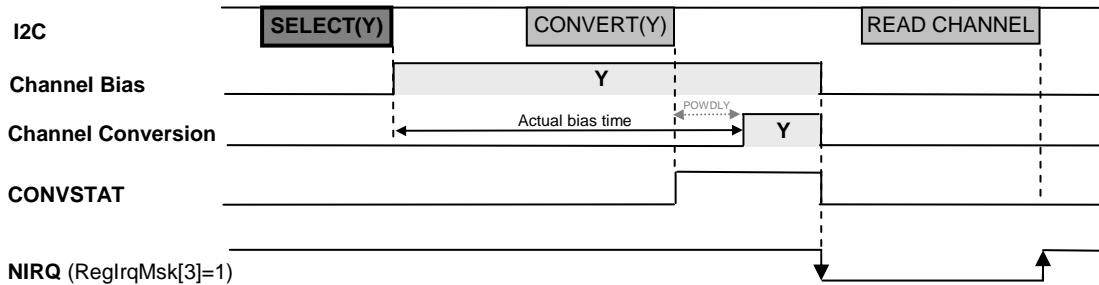


Figure 19 – Manual Mode – SELECT command (CHAN = Y; PROXSCANPERIOD = 0)

At the end of the conversion(s) bit CONVSTAT will be reset which will trigger NIRQ falling edge (if enabled in ReglrqMsk). Host can then read channel data which will release NIRQ.

Please note that when the SELECT command is used, the channel is converted whatever the pen status (no pen detection performed).

#### 4.6.3 Pen Detect Mode (PENDET)

In pen detect mode (PENDET) the chip will only run pen detection (continuously when pen is up, regularly as defined by TOUCHRATE when pen is down) and update PENSTAT bit in RegStat to be able to generate an interrupt (NIRQ) upon pen detection and/or release. No (touch) conversion is performed in this mode.

To enter PENDET mode the host must set TOUCHRATE > 0 and then send PENDET command. To quit PENDET mode and stop the touchscreen interface the host must enter MAN mode.

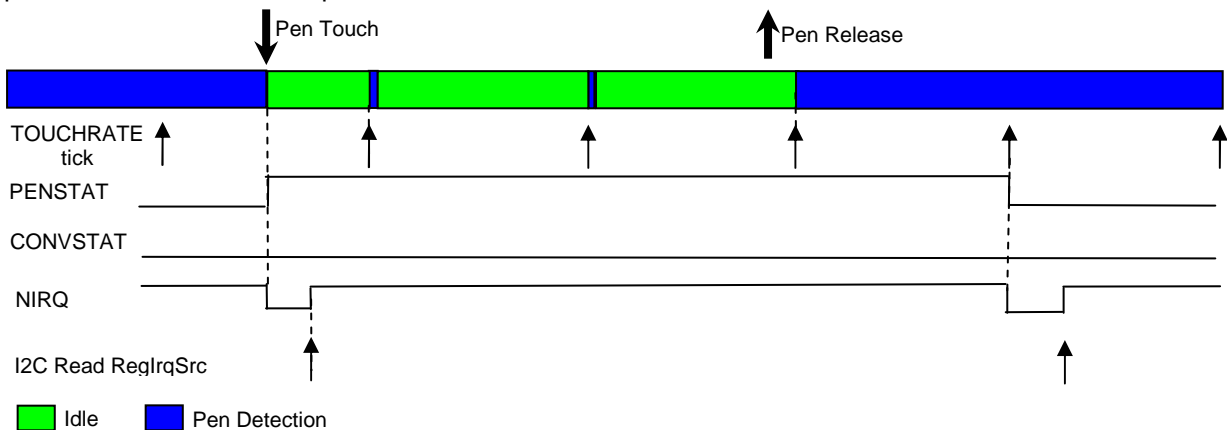


Figure 20 – Pen Detect Mode (ReglrqMsk[3:2] = 11 ; PROXSCANPERIOD = 0)

Please note that the next pen detection is not performed as long as NIRQ is low. If the host is too slow and doesn't read IrqSrc before next TOUCHRATE tick, no operation is performed and this TOUCHRATE tick is simply ignored until next one.

#### 4.6.4 Pen Trigger Mode (PENTRG)

In pen trigger mode (PENTRG) the chip will perform pen detection (continuously when pen is up, regularly as defined by TOUCHRATE when pen is down) and if pen is down, will be followed by a conversion as defined in RegChanMsk. The chip will update CONVSTAT bit in RegStat and will be able to generate an interrupt (NIRQ) upon conversion completion. The chip will also update PENSTAT bit in RegStat and will be able to generate an interrupt (NIRQ) upon pen detection and/or release.

The PENTRG mode offers the best compromise between power consumption and coordinate throughput. To enter PENTRG mode the host must set TOUCHRATE > 0 and then send PENTRG command. To quit PENTRG mode and stop the touchscreen interface the host must enter MAN mode.

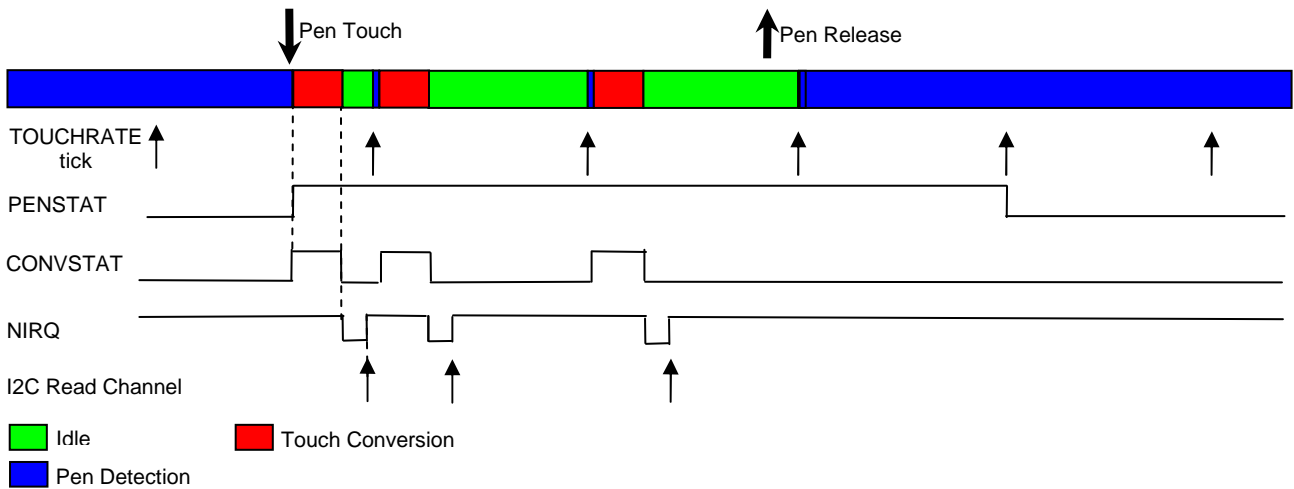
**ADVANCED COMMUNICATIONS & SENSING**


Figure 21 – Pen Trigger Mode ( $RegIrqMsk[3:2] = 10$  ;  $PROXSCANPERIOD = 0$ )

Please note that to prevent data loss, the next pen detection and conversion are not performed as long as all current channel data (i.e. channels selected in  $RegChanMsk$ ) have not been read. If the host is too slow and doesn't read all channel data before next TOUCHRATE tick, no operation is performed and this TOUCHRATE tick is simply ignored until next one.

#### 4.6.5 Maximum Throughput vs. TOUCHRATE setting

In PENTRG mode the TOUCHRATE parameter is used to define the required coordinate's throughput/rate. However, as previously mentioned, in order for a new conversion to be performed the current conversion must be completed and all relevant channel data must have been read by the host. If this condition is not met when the next TOUCHRATE tick occurs, the tick is ignored and the condition checked again at the next one. This will result in reduced actual rate vs what has been programmed in the TOUCHRATE parameter.

This is illustrated in figures below.

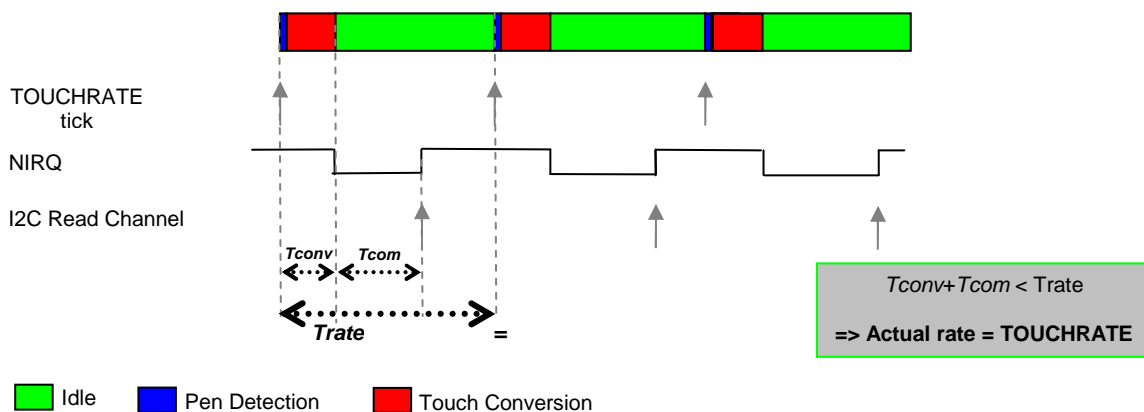


Figure 22 – Correct TOUCHRATE setting

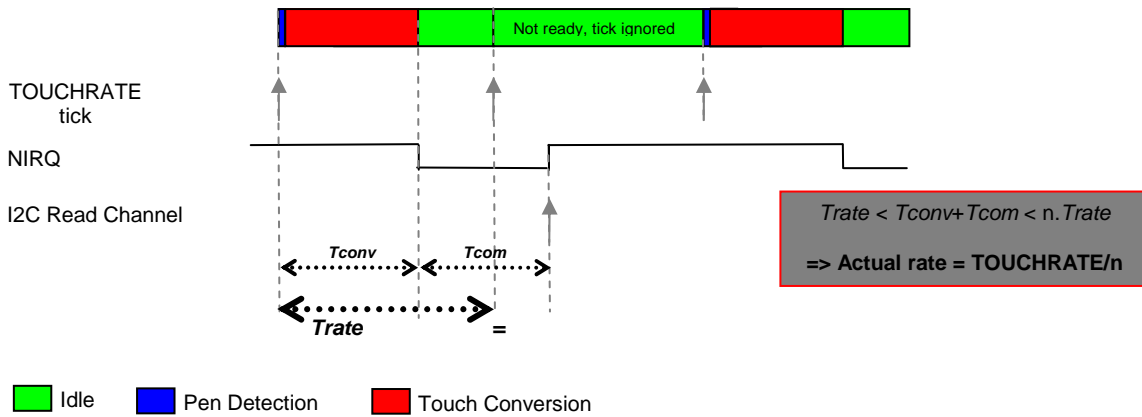
**ADVANCED COMMUNICATIONS & SENSING**


Figure 23 – Incorrect (too high) TOUCHRATE setting

In order to prevent this, one can estimate the maximum throughput achievable and set TOUCHRATE parameter accordingly.

$$\text{MaxThroughput} = 1 / (\text{Tconv} + \text{Tcom})$$

Tcom is the time between the end of conversion (ie NIRQ falling edge) and the end of channel data reading (i.e. NIRQ rising edge). Maximum throughput implies that the host reacts “instantaneously” to NIRQ falling edge:

$$T_{\text{com}} \approx (8 + 16 \times N_{\text{chan}}) \times T_{\text{I2C}}$$

Tconv is the total conversion time:

$$T_{\text{conv}}(\text{us}) = 47 \cdot T_{\text{osc}} + N_{\text{chan}} \cdot (\text{POWDLY} + (N_{\text{filt}} - 1) \cdot \text{SETDLY} + (21N_{\text{filt}} + 1) \cdot T_{\text{osc}})$$

- $T_{\text{I2C}}$  is the period of the I2C clock SCL
- $N_{\text{filt}} = \{1, 3, 5, 7\}$  based on the order defined for the filter FILT
- $N_{\text{chan}} = \{1, 2, 3, 4, 5\}$  based on the number of channels defined in RegChanMsk
- POWDLY = 0.5us to 18.19ms, settling time as defined in RegTS0
- SETDLY = 0.5us to 18.19ms, settling time when filtering as defined in RegTS2
- Tosc is the period of the internal oscillator FOSCH

Some examples of maximum throughputs achievable with an I2C running at 400kHz are given below.

Nchan	Nfilt	POWDLY [us]	SETDLY [us]	Tconv [us]	Tcom [us]	Total [us]	CR [kcps]	ECR [kcps]	SR [ksps]	ESR [ksps]
2	1	0.5	0.5	51.7	100	151.7	<b>6.6</b>	13.2	6.6	13.2
2	3	35.5	0.5	170.6	100	270.6	<b>3.7</b>	7.4	11.1	22.2
2	5	2.2	0.5	152.8	100	252.8	<b>4</b>	8	20	40
4	3	35.5	0.5	315.0	200	515	<b>1.9</b>	7.6	5.7	22.8

Table 7 – Maximum Throughputs Examples

- CR = Coordinate Rate
- ECR = Equivalent Coordinate Rate = CR x  $N_{\text{chan}}$
- SR = Sampling Rate = CR x  $N_{\text{filt}}$
- ESR = Equivalent Sampling Rate = SR x  $N_{\text{chan}} = \text{CR} \times N_{\text{filt}} \times N_{\text{chan}}$

For proper operation, the TOUCHRATE parameter should not exceed the theoretical maximum throughput CR.

**5 PROXIMITY SENSING INTERFACE (SX8657)**
**5.1 Introduction**

The purpose of the proximity sensing interface is to detect when a conductive object (usually a body part i.e. finger, palm, face, etc) is in the proximity of the system. This is commonly used in power-sensitive mobile applications to turn the screen's LCD ON/OFF depending on user's finger/palm/face proximity.

The chip's proximity sensing interface is based on capacitive sensing technology and shares the ADC with the touchscreen interface (Cf §5.4.2). An overview is given in figure below.

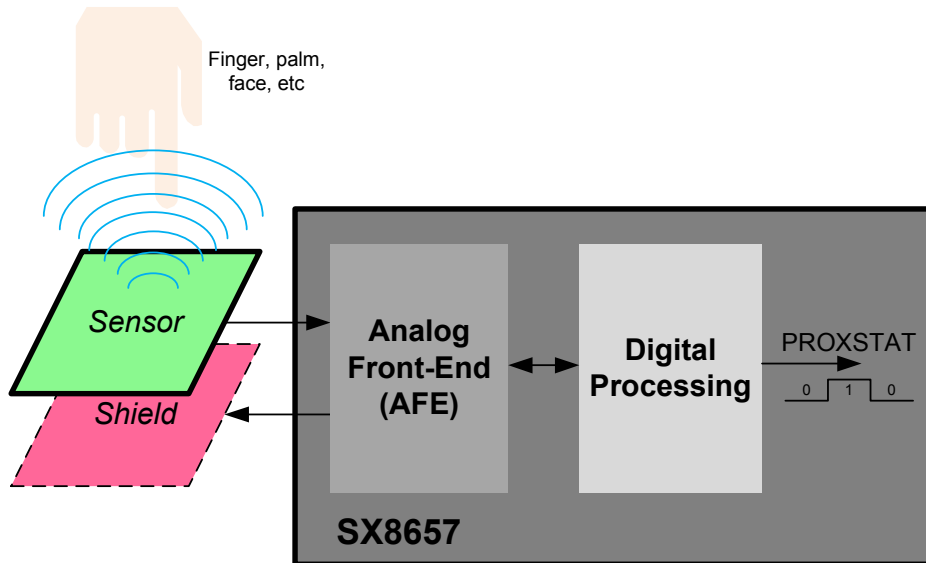


Figure 24 – Proximity Sensing Interface Overview

- ❖ The sensor can be the top layer of the touchscreen or a simple copper area on the PCB (programmable in PROXSENSORCON). Its capacitance (to ground) will vary when a conductive object is moving in its proximity.
- ❖ The optional shield can be the bottom layer of the touchscreen or a simple copper area on the PCB (programmable in PROXSHIELDCON) below/under/around the sensor. It is used to protect the sensor against potential surrounding noise sources and improve its global performance. It also brings directivity to the sensing, for example sensing objects approaching from top only.
- ❖ The analog front-end (AFE) performs the raw sensor's capacitance measurement and converts it into a 12 bit digital code. It also controls the shield. See §5.2 for more details.
- ❖ The digital processing block computes the raw capacitance measurement from the AFE and extracts a binary information PROXSTAT corresponding to the proximity status, i.e. object is "Far" or "Close". It also triggers AFE operations (compensation, etc). See §5.3 for more details.

To save power since the proximity event is slow by nature, the block will be waken-up regularly at every programmed scan period (PROXSCANPERIOD) to sense and then process a new proximity sample. The block will be in idle mode most of the time. This is illustrated in figure below

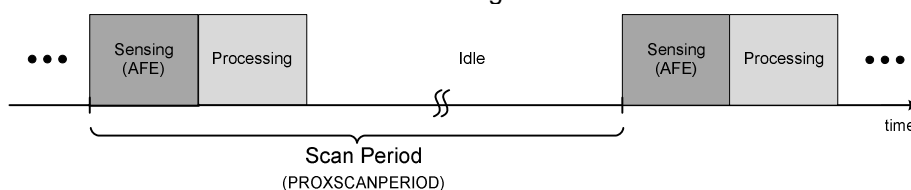


Figure 25 – Proximity Sensing Sequencing

**ADVANCED COMMUNICATIONS & SENSING**
**5.2 Analog Front-End (AFE)**
**5.2.1 Capacitive Sensing Basics**

Capacitive sensing is the art of measuring a small variation of capacitance in a noisy environment. As mentioned above, the chip's proximity sensing interface is based on capacitive sensing technology. In order to illustrate some of the user choices and compromises required when using this technology it is useful to understand its basic principles.

To illustrate the principle of capacitive sensing we will use the simplest implementation where the sensor is a copper plate on a PCB but the exact same principles apply if the sensor is the touchscreen's top plate.

The figure below shows a cross-section and top view of a typical capacitive sensing implementation. The sensor connected to the chip is a simple copper area on top layer of the PCB. It is usually surrounded (shielded) by ground for noise immunity (shield function) but also indirectly couples via the grounds areas of the rest of the system (PCB ground traces/planes, housing, etc). For obvious reasons (design, isolation, robustness ...) the sensor is stacked behind an overlay which is usually integrated in the housing of the complete system. When the touchscreen is used for sensing the overlay corresponds to the thin and flexible protection film covering the top panel.

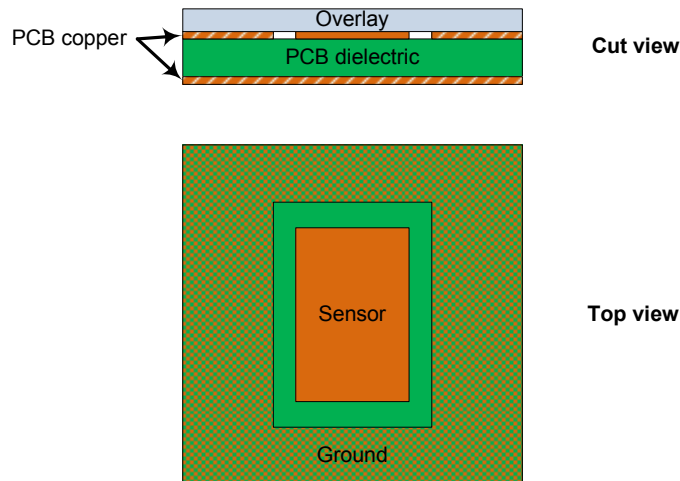


Figure 26 – Typical Capacitive Sensing Implementation

When the conductive object to be detected (finger/palm/face, etc) is not present, the sensor only sees an inherent capacitance value  $C_{Env}$  created by its electrical field's interaction with the environment, in particular with ground areas.

When the conductive object (finger/palm/face, etc) approaches, the electrical field around the sensor will be modified and the total capacitance seen by the sensor increased by the user capacitance  $C_{User}$ . This phenomenon is illustrated in the figure below.

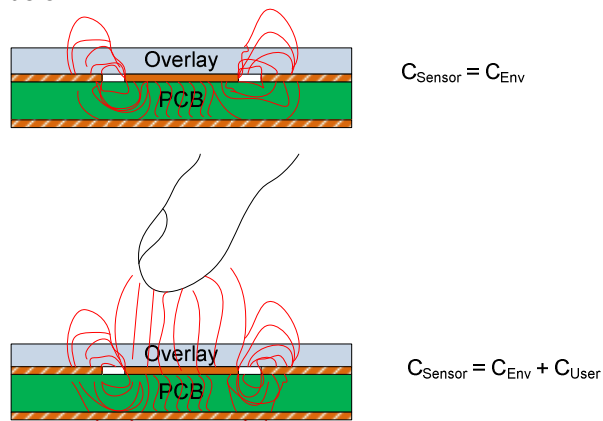


Figure 27 – Proximity Effect on Electrical Field and Sensor Capacitance

**ADVANCED COMMUNICATIONS & SENSING**

The challenge of capacitive sensing is to detect this relatively small variation of  $C_{\text{Sensor}}$  ( $C_{\text{User}}$  usually contributes for a few percents only) and differentiate it from environmental noise ( $C_{\text{Env}}$  also slowly varies together with the environment characteristics like temperature, etc). For this purpose, the chip integrates an auto offset compensation mechanism which dynamically monitors and removes the  $C_{\text{Env}}$  component to extract and process  $C_{\text{User}}$  only. See §5.2.5 for more details.

In first order,  $C_{\text{User}}$  can be estimated by the formula below:

$$C_{\text{User}} = \frac{\epsilon_0 \cdot \epsilon_r \cdot A}{d}$$

$A$  is the common area between the two electrodes hence the common area between the user's finger/palm/face and the sensor.

$d$  is the distance between the two electrodes hence the proximity distance between the user and the system.

$\epsilon_0$  is the free space permittivity and is equal to  $8.85 \cdot 10^{-12}$  F/m (constant)

$\epsilon_r$  is the dielectric relative permittivity.

When performing proximity sensing the dielectric relative permittivity is roughly equal to that of the air as the overlay is relatively thin compared to the detection distance targeted. Typical permittivity of some common materials is given in the table below.

Material	Typical $\epsilon_r$
Glass	8
FR4	5
Acrylic Glass	3
Wood	2
<b>Air</b>	<b>1</b>

From the discussions above we can conclude that the most robust and efficient design will be the one that minimizes  $C_{\text{Env}}$  value and variations while improving  $C_{\text{User}}$ .

### 5.2.2 AFE Block Diagram

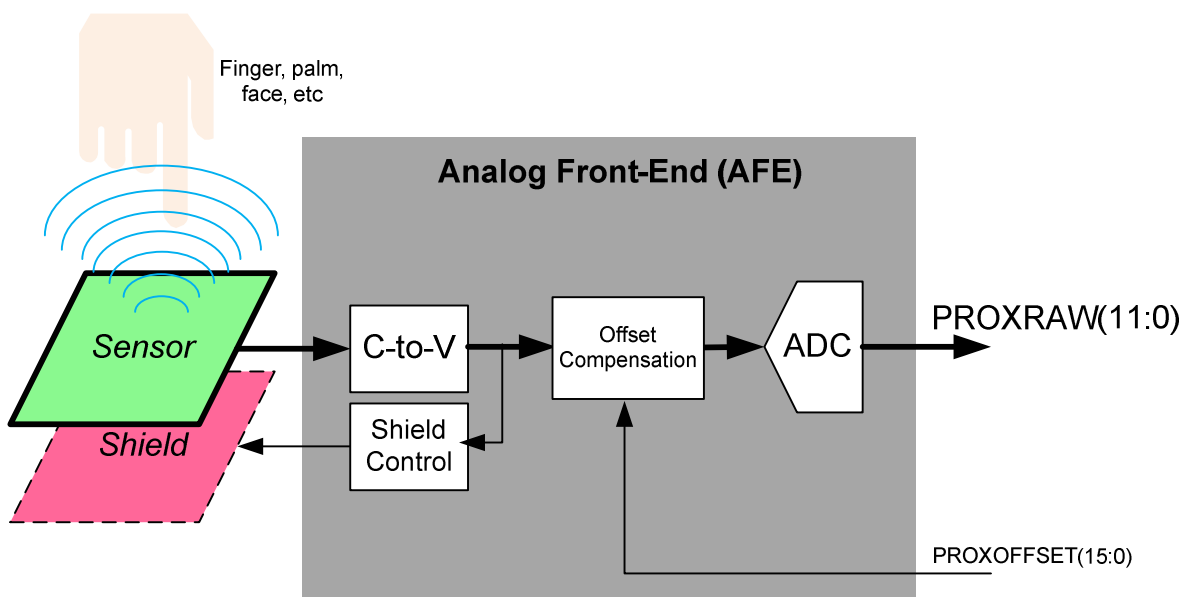


Figure 28 – Analog Front-End Block Diagram

**ADVANCED COMMUNICATIONS & SENSING**
**5.2.3 Capacitance-to-Voltage Conversion (C-to-V)**

PROXSENSORCON defines which pin will act as the sensor during proximity sensing operations. In the typical case, the touchscreen top layer is used as the sensor (exact pin/electrode depends on screen type/structure). Else, the sensor can also be “external”, i.e. connected to AUX2.

The sensitivity of the interface is defined by PROXSENSITIVITY; for obvious power consumption reasons it is recommended to set it as low as possible.

As a last resort and only if the sensor is “external”, PROXBOOST can be set to allow higher sensitivity if needed.

PROXFREQ defines the operating frequency of the interface and should be set as high as possible for power consumption reasons.

If needed, PROXHIGHIM enables a high noise immunity mode at the expense of increased power consumption.

**5.2.4 Shield Control**

PROXSHIELDCON defines which pin will act as the shield during proximity sensing operations. In the typical case, the shield will usually be the touchscreen bottom layer (exact pin/electrode depends on screen type/structure). Else, the shield can also be “external”, ie a simple copper area on the PCB connected to AUX3.

**5.2.5 Offset Compensation**

Offset compensation consists in performing a one time measurement of  $C_{Env}$  and subtracting it to the total capacitance  $C_{Sensor}$  in order to feed the ADC with the closest contribution of  $C_{User}$  only.

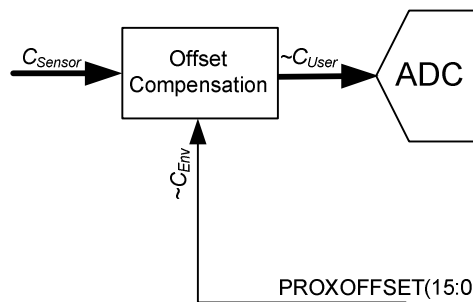


Figure 29 – Offset Compensation Block Diagram

The ADC input  $C_{User}$  is the total capacitance  $C_{Sensor}$  to which  $C_{Env}$  is subtracted.

There are five possible compensation sources which are illustrated in the figure below. When set to 1 by any of these sources, PROXCOMPSTAT will only be reset once the compensation is completed.

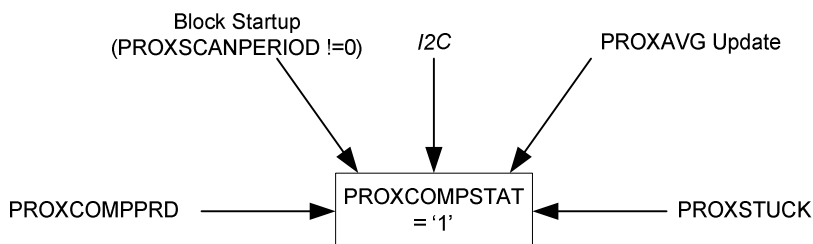


Figure 30 – Compensation Request Sources

## ADVANCED COMMUNICATIONS & SENSING

- **Block startup:** a compensation is automatically requested when the proximity sensing is enabled via PROXSCANPERIOD.
- **I2C:** a compensation can be manually requested anytime by the host through I2C interface.
- **PROXAVG update:** a compensation can be automatically requested if it is detected that  $C_{Env}$  has drifted beyond a set level since the last compensation.
- **PROXCOMPPRD:** a compensation can be automatically requested at a predefined rate programmed by the host.
- **PROXSTUCK:** a compensation can be automatically requested if it is detected that the proximity "Close" state is lasting abnormally long.

Please note that the compensation request flag can be set anytime but the compensation itself is always done at the beginning of a scan period to keep all parameters coherent (PROXRAW, PROXAVG, PROXDIF), see §5.3.2.

### 5.2.6 Analog-to-Digital Conversion (ADC)

A 12-bit ADC is used to convert the capacitance information into a digital 12-bit word PROXRAW.

The ADC is shared with the touchscreen interface using time multiplexing (see §5.4.2 for more details).

## 5.3 Digital Processing

### 5.3.1 Overview

The main purpose of the digital processing block is to convert the raw capacitance information coming from the AFE (PROXRAW) into a robust and reliable digital flag (PROXSTAT) indicating if the user's finger/hand/head is close to the proximity sensor.

The offset compensation performed in the AFE is a one time measurement. However, the environment capacitance  $C_{Env}$  may vary with time (temperature, nearby objects, etc). Hence, in order to get the best estimation of  $C_{User}$  (PROXDIF) it is needed to dynamically track and subtract  $C_{Env}$  variations. This is performed by filtering PROXUSEFUL to extract its slow variations (PROXAVG).

PROXDIF is then compared to user programmable threshold to extract PROXSTAT flag.

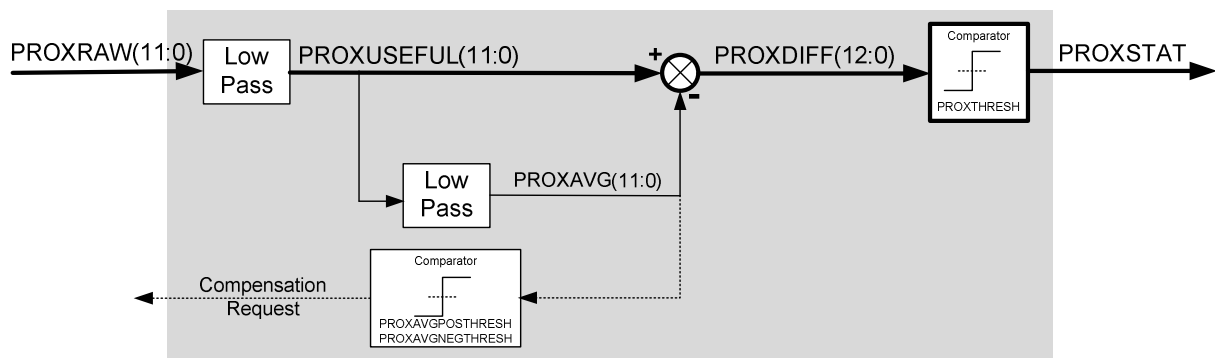
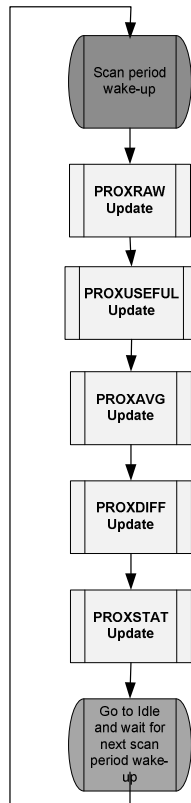


Figure 31 – Digital Processing Block Diagram

Digital processing sequencing is illustrated in figure below. At every scan period wake-up (defined by PROXSCANPERIOD), the block updates sequentially PROXRRAW, PROXUSEFUL, PROXAVG, PROXDIF and PROXSTAT before going back to Idle mode.



*Figure 32 – Digital Processing Sequencing*

Digital processing block also updates CONVSTAT (set during proximity operations) and PROXCOMPSTAT (set when compensation is currently pending execution or competition)

### 5.3.2 PROXRAW Update

PROXRAW update consists mainly in starting the AFE and waiting for the new PROXRAW value to be ready. If a compensation was pending it is performed first.

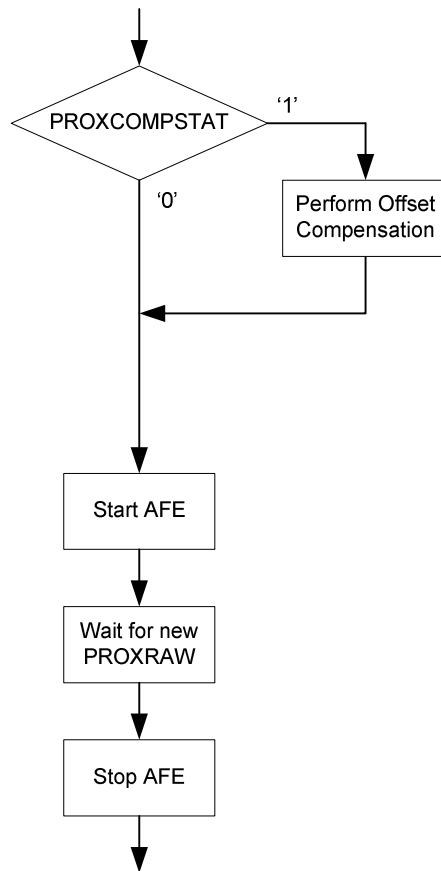


Figure 33 – ProxRaw Update

### 5.3.3 PROXUSEFUL Update

PROXUSEFUL update consists in filtering PROXRRAW upfront to remove its potential high frequencies components(system noise, interferer, etc) and extract only user activity (few Hz max) and slow environment changes.

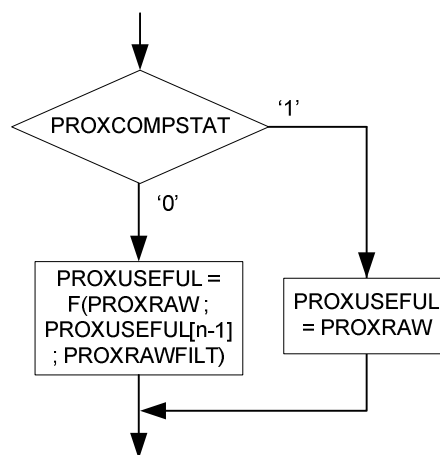


Figure 34 – PROXUSEFUL Update

$$F(\text{PROXRRAW} ; \text{PROXUSEFUL}[n-1] ; \text{PROXRRAWFILT}) = (1 - \text{PROXRRAWFILT}).\text{PROXRRAW} + \text{PROXRRAWFILT}.\text{PROXUSEFUL}[n-1]$$

**ADVANCED COMMUNICATIONS & SENSING**
**5.3.4 PROXAVG Update**

PROXAVG update consists in averaging PROXUSEFUL to ignore its “fast” variations (i.e. user finger/palm/hand) and extract only the very slow variations of environment capacitance  $C_{Env}$ .

One can program positive and negative debounced thresholds (PROXAVGPOSTHRESH/PROXAVGPOSDEB and PROXAVGNEGTHRESH/PROXAVGNEGDEB) within which PROXAVG can vary without triggering compensation (ie small acceptable environment drift).

Large positive values of PROXUSEFUL are considered as normal (user finger/hand/head) but large negative values are considered abnormal and should be compensated quickly. For this purpose, the averaging filter coefficient can be set independently for positive and negative variations via PROXAVGPOSFILT and PROXAVGNEGFILT. Typically we have PROXAVGPOSFILT > PROXAVGNEGFILT to filter out (abnormal) negative events faster.

To prevent PROXAVG to be “corrupted” by user activity (should only reflect environmental changes) it is freezes when proximity is detected.

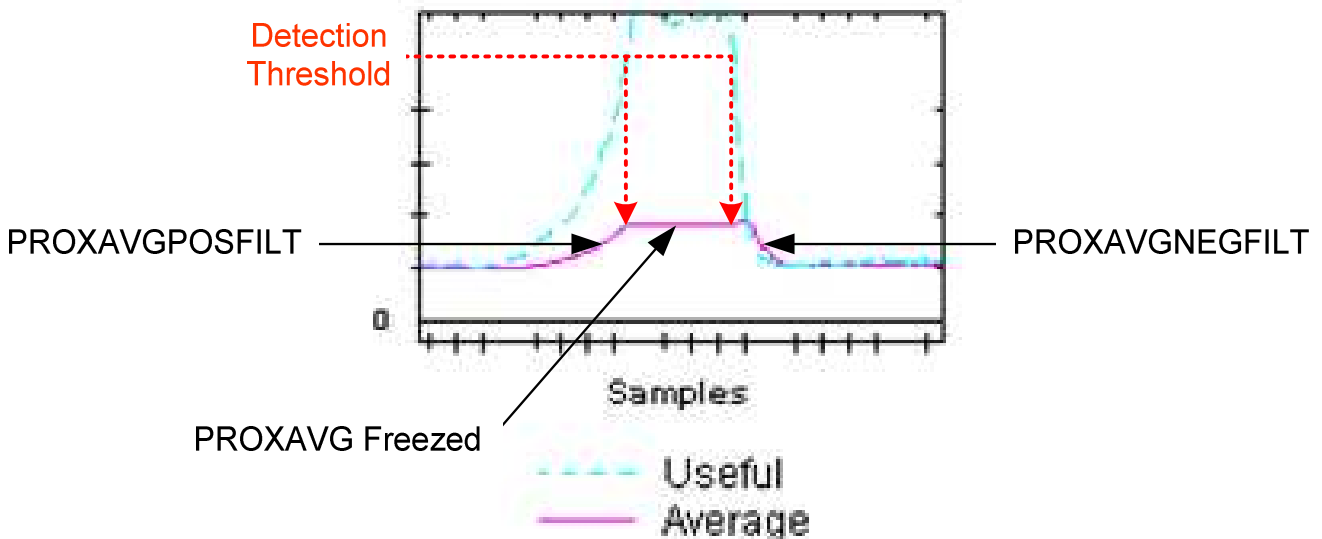


Figure 35 – ProxAvg vs Proximity Event

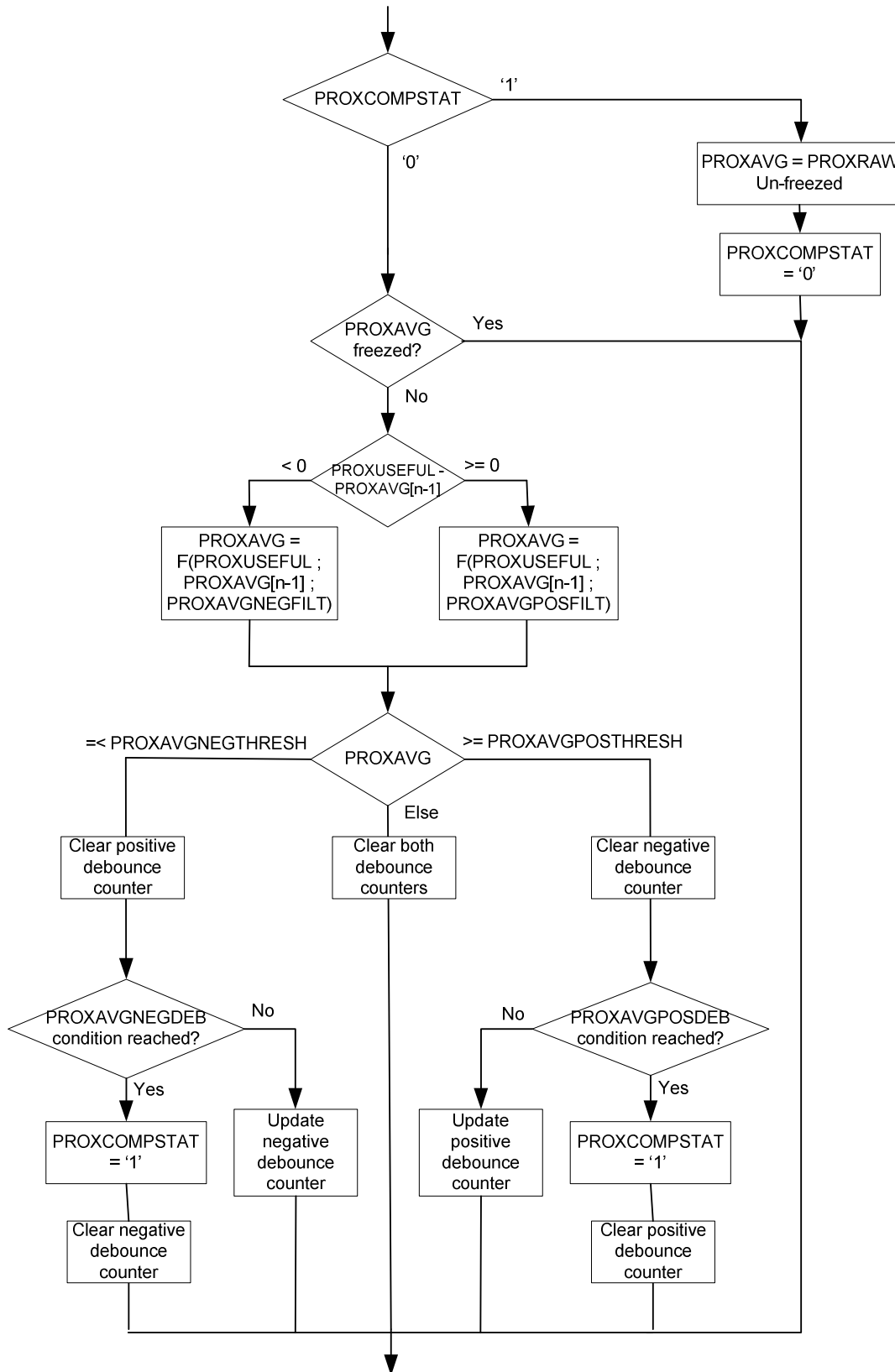


Figure 36 – ProxAvg Update

$$F(\text{PROXUSEFUL} ; \text{PROXAVG}[n-1] ; \text{PROXAVG}_{\text{xxx}}\text{FILT}) = (1 - \text{PROXAVG}_{\text{xxx}}\text{FILT}) \cdot \text{PROXUSEFUL} + \text{PROXAVG}_{\text{xxx}}\text{FILT} \cdot \text{PROXAVG}[n-1]$$

xxx = POS or NEG

**ADVANCED COMMUNICATIONS & SENSING**
**5.3.5 PROXDIFF Update**

PROXDIFF update consists in the complementary operation i.e. subtracting PROXAVG to PROXUSEFUL to ignore slow capacitances variations ( $C_{Env}$ ) and extract only the user related variations i.e.  $C_{User}$ .

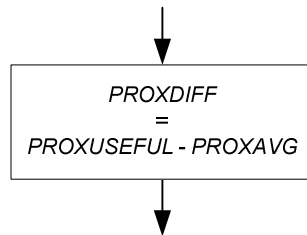


Figure 37 – ProxDiff Update

**5.3.6 PROXSTAT Update**

PROXSTAT update consists in taking PROXDIFF information ( $C_{User}$ ), comparing it with a user programmable threshold PROXTHRESH and finally updating PROXSTAT accordingly. When PROXSTAT=1, PROXAVG is frozen to prevent the user proximity signal averaging and hence absorbed into  $C_{Env}$ .

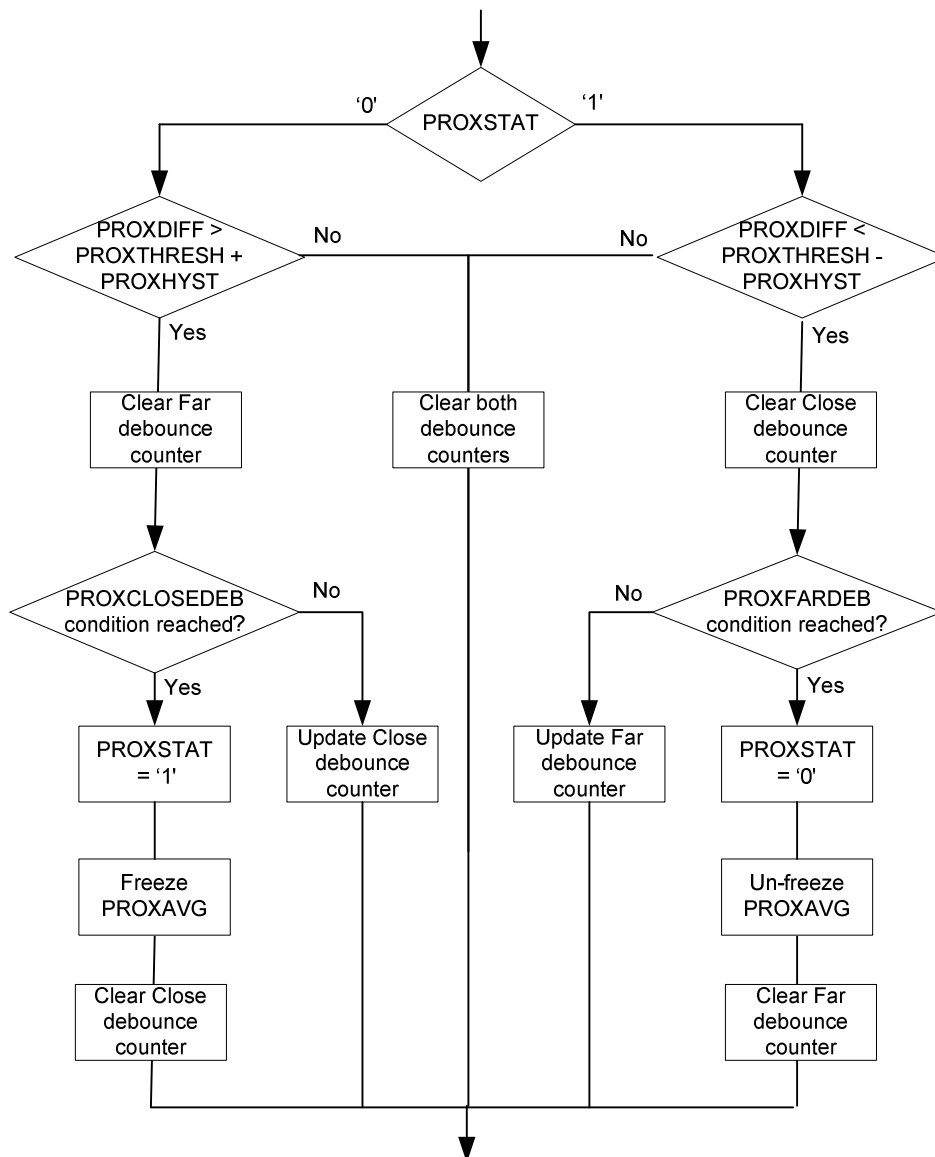


Figure 38 – PROXSTAT Update

**ADVANCED COMMUNICATIONS & SENSING**
**5.4 Host Operation**
**5.4.1 General Description**

If  $PROXIRQSEL = 0$ , an interrupt can be triggered when the user is detected to be close, detected to be far, or both ( $PROXCLOSEIRQEN$ ,  $PROXFARIRQEN$ ).

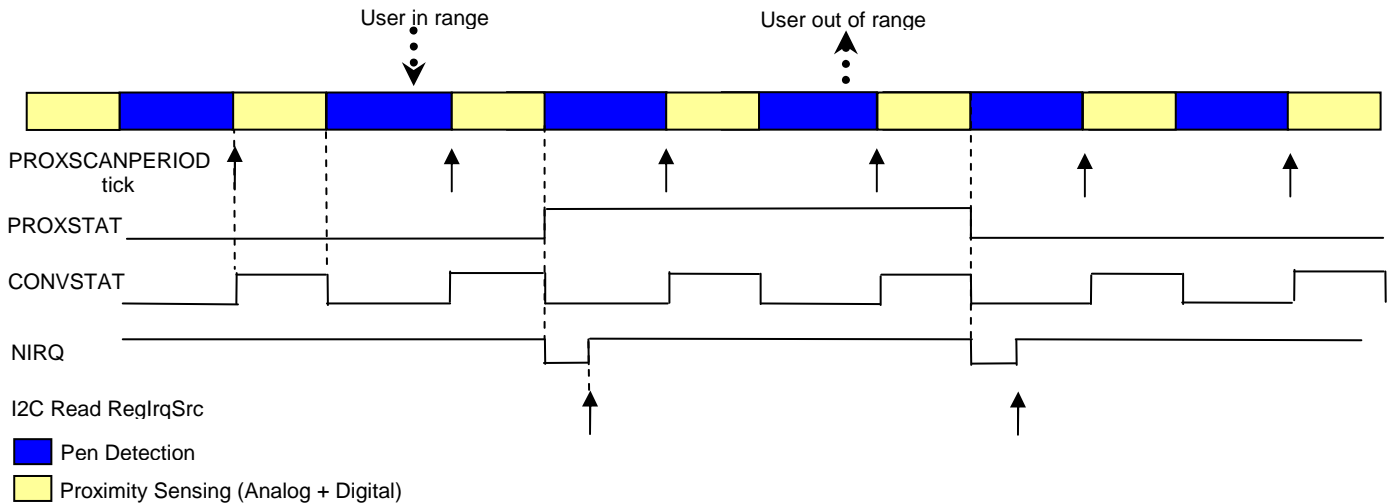


Figure 39 – Proximity Sensing Host Operation (Pen Trigger Mode ;  $RegIrqMsk[6:4] = 110$  ;  $PROXIRQSEL = 0$ )

If  $PROXIRQSEL = 1$ , instead of the proximity “Far” state, an interrupt can be triggered at the end of each proximity sensing operation indicating to the host when the proximity sensing block is running ( $PROXCONVDONEIRQEN$ ). This may be used by the host to synchronize noisy system operations or to read  $PROXRAW$ ,  $PROXUSEFUL$ ,  $PROXAVG$ ,  $PROXDIF$  synchronously for monitoring purposes.

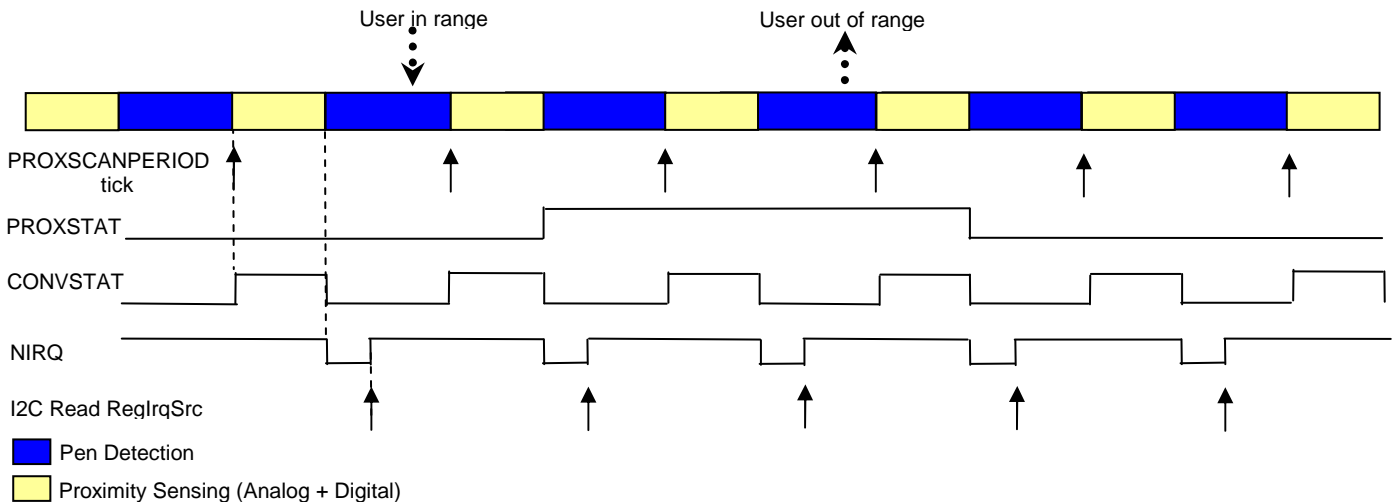


Figure 40 – Proximity Sensing Host Operation (Pen Trigger Mode ;  $RegIrqMsk[6:4] = 010$  ;  $PROXIRQSEL = 1$ )

In both cases above, an interrupt can also be triggered at the end of compensation ( $PROXCOMPDONEEN$ ).

**5.4.2 Proximity Sensing vs Touch Operations**

As previously mentioned, touch and proximity operations share the same ADC and hence the chip implements time multiplexing between these two types of operations. Also, proximity sensing doesn't need to be performed while pen is down (not needed as host knows already something touches the screen).

In all operating modes, if  $PROXSCANPERIOD = 0$ , no proximity operation is performed (i.e. §4.6). The following hence assumes  $PROXSCANPERIOD \neq 0$ . For simplicity we also assume that  $NIRQ$  is only used for reporting touch operations i.e.  $RegIrqMsk[6:4] = 000$  ( $PROXSTAT$  mapped to AUX pin, or polled via I2C).

In MAN mode, a  $CONVERT$  command (if not preceded by a  $SELECT$  command) will perform a proximity sensing operation before the touchscreen operation, whatever the pen status. Hence please note that if the

**ADVANCED COMMUNICATIONS & SENSING**

touchscreen is used as the proximity sensor and is being touched when the conversion is performed, the proximity measurement result may be incorrect.

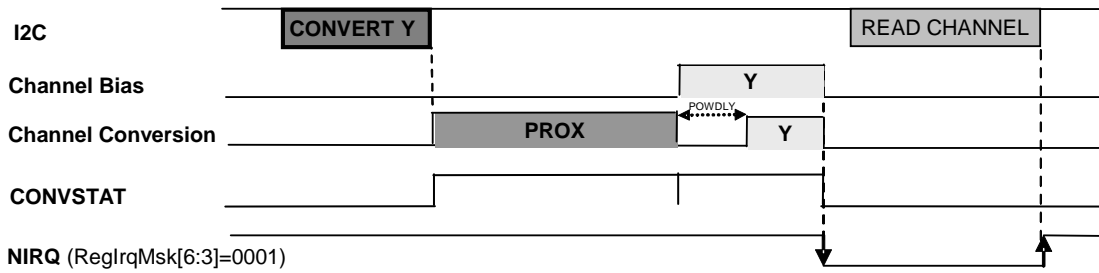


Figure 41 – Manual Mode – CONVERT Command (CHAN = Y ; PROXSCANPERIOD != 0; Pen down)

If the screen is not touched, only the proximity sensing operation is performed.

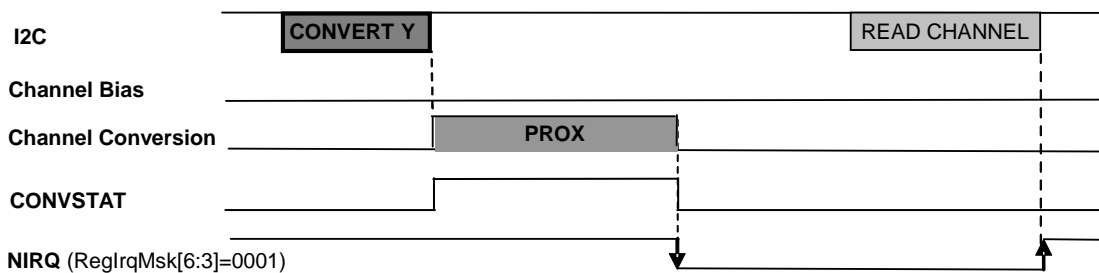


Figure 42 – Manual Mode – CONVERT Command (CHAN = Y ; PROXSCANPERIOD != 0, Pen up)

In PENDET and PENTRG mode, a proximity sensing operation will be performed regularly as defined in PROXSCANPERIOD, but only if pen is not detected.

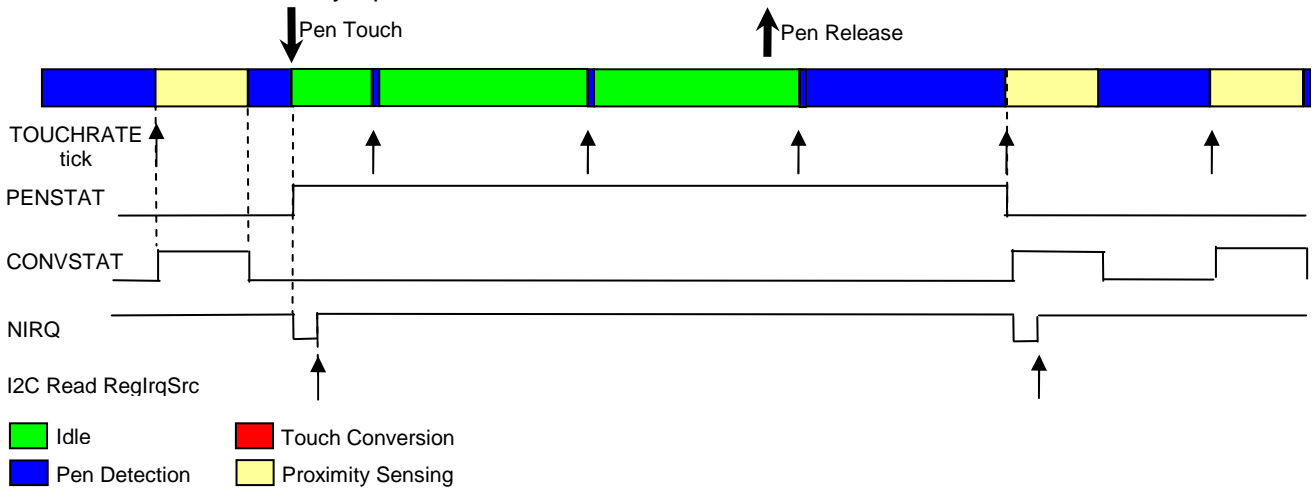


Figure 43 – Pen Detect Mode (ReglrqMsk[6:2] = 00011 ; PROXSCANPERIOD = 001 ie 1/TOUCHRATE)

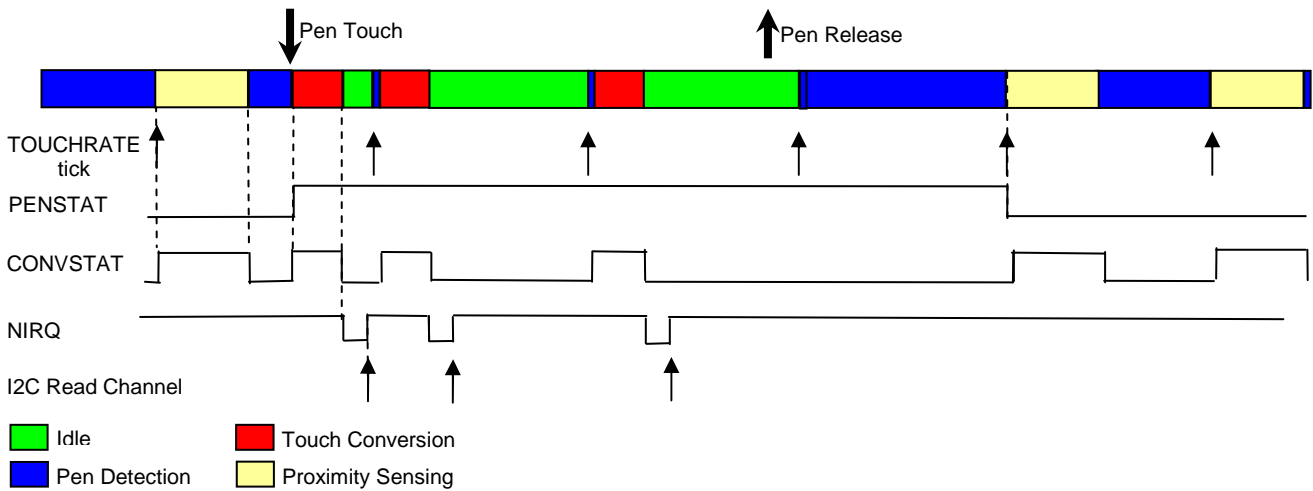
**ADVANCED COMMUNICATIONS & SENSING**


Figure 44 – Pen Trigger Mode (RegIrqMsk[6:2] = 00010 ; PROXSCANPERIOD = 001 ie 1/TOUHRATE)

### 5.4.3 Minimum Scan Period (i.e. PROXSCANPERIOD)

Similarly to touch operations (Cf. §4.6.5), if PROXSCANPERIOD is too short for proximity sensing operations to be completed, the rate tick(s) affected are ignored until operations are completed and the following tick is taken into account for the next planned operation.

Please note that compensation lasts about ~16 times longer than a normal proximity sensing operation.

**6 HAPTICS INTERFACE (SX8657/58)**
**6.1 Introduction**

Haptics technology is commonly used in systems which include a touchscreen interface. Its purpose is to provide tactile feedback to the user to acknowledge a touch event hence improving greatly the robustness of the system and user comfort and perception.

The on-chip haptics interface is designed to drive two common actuator types: Eccentric Rotating Mass (ERM) and Linear Resonant Actuator (LRA). This is performed without any external component due to fully embedded analog processing and with very limited host interaction due to the embedded digital processing block.

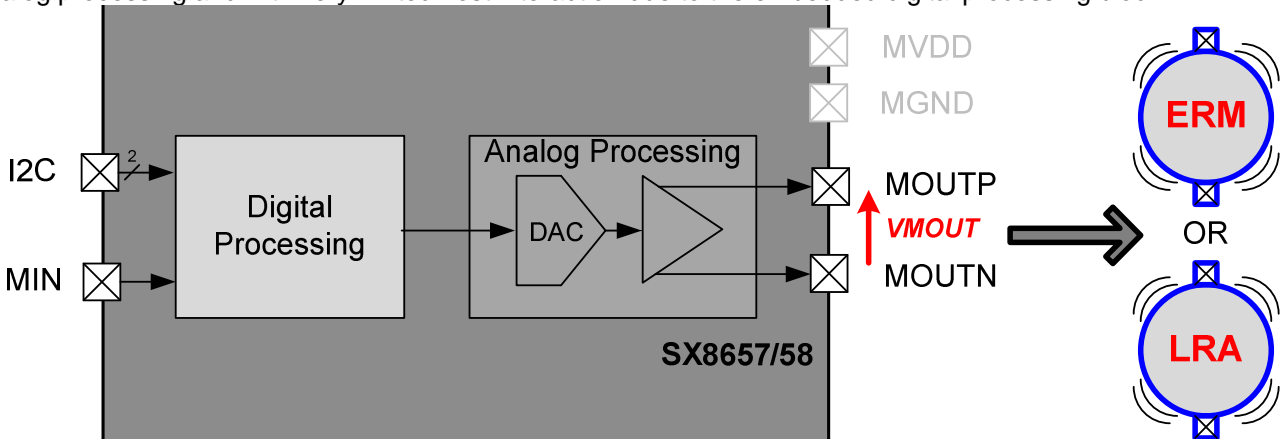


Figure 45 – Haptics Interface Overview

The host configures drive parameters from the I2C port according to the particular haptics load to be used. The haptics drive level is then controlled in real time by either of two methods: by a dedicated digital pin, MIN, which accepts a pulse-width-modulated (PWM) digital signal; or by writing the desired output level directly to a register via the I2C interface.

This digital information is filtered to prevent fast transitions and hence high current spikes (HAPTBW), converted into the analog domain by an 8-bit DAC, and finally amplified (HAPTGAIN) to provide a differential signal between MOUTP and MOUTN pins which can be directly connected to the motor thanks to their high drive current capability.

For better isolation from the rest of the chip, the haptics interface analog block has its own power supply pins MVDD and MGND.

The haptics interface is enabled when HAPTTYPEEN != 0.

**6.2 ERM Load**
**6.2.1 Introduction**

An ERM is a DC motor with an off-balance load to create a vibration. Speed and direction are controlled by the applied voltage. The ERM load is selected when HAPTTYPEEN = 10.

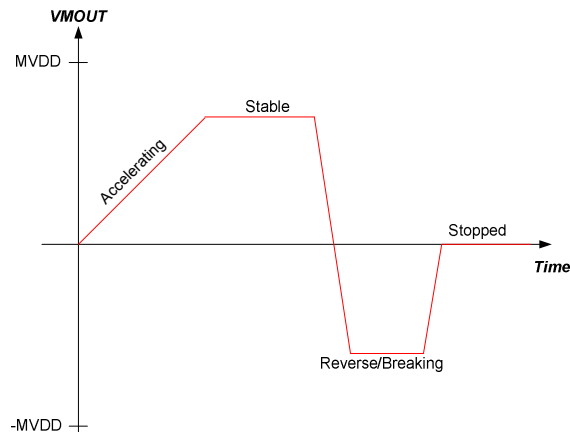


Figure 46 – ERM Drive Signal Example

If AmplitudeCode is within HAPTSQUELCH range (for more than 512/MIN\_Freq in PWM mode, for more than 512/FOSCL in I2C mode):

$$VMOUT = 0V$$

Else:

$$VMOUT(V) = (AmplitudeCode / 127) \times 1.135 \times HAPTAIN$$

AmplitudeCode (signed) is defined differently depending on the mode selected (PWM or I2C), see below.

Please note that whatever setting, VMOUT is physically limited to [MVDD;-MVDD], i.e. saturation effect.

### 6.2.2 PWM Mode

PWM mode is selected when HAPTMODE = 0.

In this mode, AmplitudeCode is extracted/updated at each MIN period from MIN\_DutyCycle:

- MIN\_DutyCycle ≈ 0% => AmplitudeCode = -127
- ...
- MIN\_DutyCycle = 49.6% => AmplitudeCode = -1
- MIN\_DutyCycle = 50% => AmplitudeCode = 0
- MIN\_DutyCycle = 50.4% => AmplitudeCode = +1
- ...
- MIN\_DutyCycle ≈ 100% => AmplitudeCode = +127

### 6.2.3 I2C Mode

I2C mode is selected when HAPTMODE = 1.

In this mode, AmplitudeCode = HAPTAMP (signed, internally sampled at FOSCL). MIN is not used and should be grounded. HAPTRANGE must be set to 1.

## 6.3 LRA Load

### 6.3.1 Introduction

An LRA is a spring and mass with an electro-magnetic coil to move the mass. It is operated by applying an AC signal at its resonant frequency (typ. ~175 Hz). Like pushing a swing at its resonance, it doesn't need much energy to keep it going, so drive current requirements are much lower than for ERMs. LRAs have moderately high Q factors so that the drive frequency must match the resonant frequency within a few Hz to get optimum amplitude.

LRA load is selected when HAPTTYPEEN = 01.

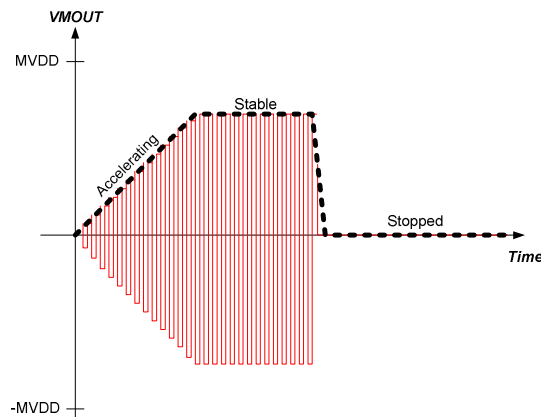


Figure 47 – LRA Drive Signal Example

The carrier frequency of VMOUT\_Freq is defined as following:

$$VMOUT\_Freq(Hz) = (MIN\_Freq / HAPTRANGE) \quad (\text{PWM mode})$$

OR

$$VMOUT\_Freq(Hz) = (MIN\_Freq / HAPTRANGE) / (HAPTTIMER + 1) \quad (\text{I2C mode})$$

If AmplitudeCode is within HAPTSQUELCH range (for more than 512/VMOUT\_Freq):

$$VMOUT\_Envelope = 0V$$

Else:

$$VMOUT\_Envelope(V) = (AmplitudeCode / 127) \times 1.135 \times HAPTGAIN$$

AmplitudeCode (signed) is defined differently depending on the mode selected (PWM or I2C), see below.

Please note that whatever setting, VMOUT is physically limited to [MVDD;-MVDD], ie saturation effect.

### 6.3.2 PWM Mode

PWM mode is selected when HAPTMODE = 0.

In this mode, AmplitudeCode is extracted/updated at each MIN period from MIN\_DutyCycle:

- MIN\_DutyCycle ≈ 0% => AmplitudeCode = -127
- ...
- MIN\_DutyCycle = 49.6% => AmplitudeCode = -1
- MIN\_DutyCycle = 50% => AmplitudeCode = 0
- MIN\_DutyCycle = 50.4% => AmplitudeCode = +1
- ...
- MIN\_DutyCycle ≈ 100% => AmplitudeCode = +127

### 6.3.3 I2C Mode

I2C mode is selected when HAPTMODE = 1.

In this mode, AmplitudeCode = HAPTAMP (signed, internally sampled at MIN\_Freq). MIN is still used to extract VMOUT carrier frequency.

## 6.4 Short-Circuit Protection

The haptics interface integrates a short-circuit protection circuit which detects when MIDD is abnormally high i.e. above ISHORT. Under a short-circuit event (HAPTSHORTSTAT=1) the haptics block will stop operation (MOUTN & MOUTP grounded). When the short-circuit is removed the haptics operations will resume normally.

**7 TEMPERATURE SENSOR**

The chip includes a temperature sensor which monitors the chip's junction temperature. Its purpose is to provide over-temperature information to the host and if needed automatically shutdown chip operation for thermal protection.

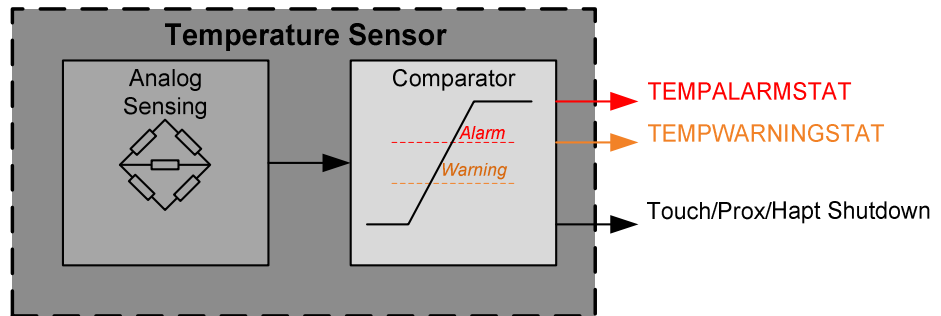


Figure 48 – Temperature Sensor Overview

If `TEMPALWAYSON = 0` (default), the temperature sensor will perform measurements only if the chip is active i.e. touchscreen interface running (Op. Mode  $\neq$  MAN), proximity sensing interface enabled (`PROXSCANPERIOD  $\neq$  0`) or haptics interface enabled (`HAPTTYPEEN  $\neq$  00`). The temperature sensor will perform a measurement every  $\sim 32$  ms ( $1024/\text{FOSCL}$ ) but not during ADC conversions (temperature sensing delayed accordingly).

If `TEMPALWAYSON = 1`, the temperature sensor will always perform a measurement every  $\sim 32$  ms independently from chip activity (i.e. also when the chip is inactive and during ADC conversions).

Each measurement is compared with two internally hard-coded thresholds:

- Warning level: typ.  $120^{\circ}\text{C}$  (TWRNG).
- Alarm level: typ.  $155^{\circ}\text{C}$  (TALRM)

Each of these thresholds is associated to a status flag (`TEMPWARNINGSTAT`, `TEMPALARMSTAT`) which edges can be mapped to generate an interrupt to the host.

Additionally, during an alarm situation (i.e. temperature  $>$  alarm level) all chip operations (i.e. touchscreen, proximity, haptics) are automatically shutdown until the temperature goes below the alarm level.

After a shutdown event all stored conversion data are thrown away. Cycling operations (`TOUCHRATE  $>$  0`) will resume from the start (i.e. if a 4 channel conversion is stopped during the 3<sup>rd</sup> channel conversion, when resuming, the 4 channels will be converted again). If the user was running some manual operation (`SELECT`, `CONVERT`), the corresponding command will have to be re-issued. The haptics operations will resume directly.

## **8 INTERRUPT (NIRQ)**

### **8.1 Introduction**

The purpose of the NIRQ pin is to indicate to the host (via a falling edge) when any of the events considered being time-critical has occurred. Non time-critical events can be monitored via I2C by reading regularly the relevant status bits.

### **8.2 Registers Overview**

#### 8.2.1 RegIrqMsk

This register allows the host to decide which interrupt sources he wants to monitor via the NIRQ signal. Please note that a reset event will always trigger NIRQ falling edge whatever RegIrqMsk (Cf §10)

#### 8.2.2 RegIrqSrc

This register indicates to the host which of the interrupt sources triggered the NIRQ signal. More than one bit can be set if several events occurred before host reads the register.

If bit 3 is OFF, reading the register will clear it together with releasing NIRQ signal. Else, if bit 3 is ON and we are in MAN or PENTRG mode, both register and NIRQ will be cleared only once all channel data have been read. All ADC related operations (touch conversion, proximity conversion, pen detection) are stopped as long as all channel data have not been read.

Bits which RegIrqMsk corresponding bits are set to 0 (ie source not monitored) will always read 0 even if the event actually occurred.

#### 8.2.3 RegStat

This register regroups all status information of the chip and is used by all interrupt sources to detect the relevant events. For each bit, if the relevant block is ON its value is constantly updated, else it is set to 0. This register update is completely independent from RegIrqMsk.

### **8.3 Host Procedure**

- Configure the different blocks parameters (TS, Proximity, etc)
- Program RegIrqMsk to start monitoring what is considered to be “time-critical” events
- Enable the blocks to start RegStat update and hence NIRQ process.
- Each time NIRQ falling edge occurs, read RegIrqSrc to know which “time-critical” event occurred (+ read channel data if relevant)
- In addition, RegStat can be read anytime to get the whole picture including also what is considered to be “non time-critical” information.

**9 AUXILIARY PINS (AUX1/AUX2/AUX3)**

The chip has three auxiliary pins which can be used:

1. By the touchscreen interface when using a 5-wire touchscreen (WIPER=AUX1)
2. By the proximity sensing interface (PROXSENSORCON and PROXSHIELDCON) to use an external sensor and/or shield instead of the touchscreen's plates
3. By the host (RegAux0-1) to monitor any RegStat and/or RegIrqSrc bits in real time without having to use NIRQ or perform I2C polling.

**10 RESET**
**10.1 Hardware (POR and NRST)**

The chip generates its own power on reset (POR) signal after a power supply is connected to the VDD pin. NRST input pin can be used to reset the chip anytime, it must be connected to VDD (or greater) either directly (if not used), or via a resistor.

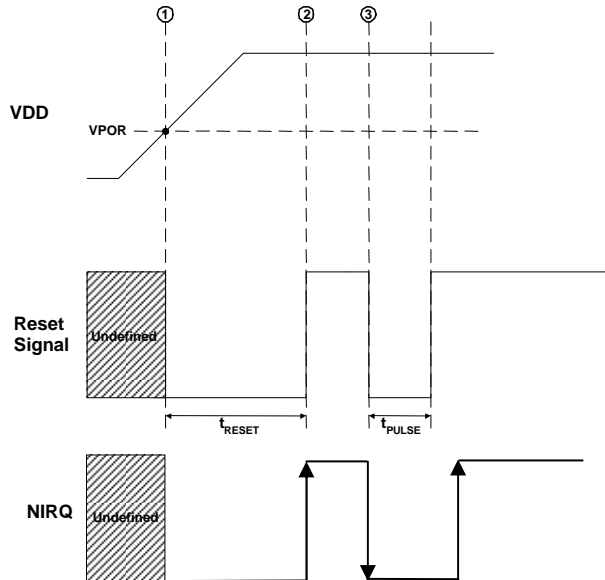


Figure 49 – Hardware Reset Conditions

1. Device behavior is undefined until VDD rises above VPOR, at which point internal reset procedure is started and NIRQ is kept low.
2. After  $t_{\text{RESET}}$ , the reset procedure is completed and NIRQ is released high.
3. In operation, the chip may be reset at anytime by an external device driving NRST low for  $t_{\text{PULSE}}$  or longer. NIRQ will go low during the reset phase and chip can be accessed normally again after NIRQ rising edge. Additionally bit RESETSTAT will be set (cleared when reading RegStat)

**10.2 Software (RegReset)**

Writing 0xDE to RegReset register will reset the chip and all registers to their default values. NIRQ will go low during the reset phase and chip can be accessed normally again after NIRQ rising edge. Additionally bit RESETSTAT will be set (cleared when reading RegStat).

**10.3 ESD Event (RESETSTAT)**

In case of ESD event, the chip can reset to protect its internal circuitry. NIRQ will go low during the reset phase and chip can be accessed normally again after NIRQ rising edge. Additionally bit RESETSTAT will be set (cleared when reading RegStat).

**ADVANCED COMMUNICATIONS & SENSING**
**11 I2C INTERFACE**
**11.1 Introduction**

The chip is a read-write slave-mode I2C device and complies with the Philips I2C standard Version 2.1 dated January, 2000. The chip has a few user-accessible internal 8-bits registers to set the various parameters of operation (Cf. §12 for detailed configuration registers description). The I2C interface has been designed for program flexibility, in that once the slave address has been sent to the chip enabling it to be a slave transmitter/receiver, any register can be written or read independently of each other. The start and stop commands frame the data-packet and the repeat start condition is allowed if necessary.

2 lines are used to exchange data between an external master host and the slave device:

- **SCL** : Serial **C**Lock
- **SDA** : Serial **D**Ata

Seven bit addressing is used and ten bit addressing is not allowed. Any general call address will be ignored by the chip. The chip is not CBUS compatible and can operate in standard mode (100kbit/s) or fast mode (400kbit/s).

**11.2 I2C Address**

On the QFN package an ADDR pin is made available to select between the two pre-programmed I2C addresses of the device. On the CSP package ADDR is internally connected to ground.

This is illustrated in table below.

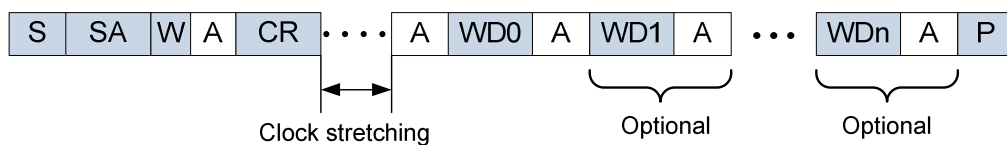
Package	ADDR	Address	Description
QFN	0	0x48 (1001000)	First I2C address
	1	0x49 (1001001)	Second I2C address
CSP	0	0x48 (1001000)	First (and unique) I2C address

Table 8 – I2C Address

Please note that upon request, a custom I2C Address can be pre-programmed by Semtech.

**11.3 Write Register**

The I2C write register sequence is given in figure below. After the start condition [S], the chip slave address (SA) is sent, followed by an eighth bit (W='0') indicating a write. The chip then acknowledges [A] that it is being addressed, and the host sends a CR byte consisting in '00' followed by the chip register address (RA). The chip acknowledges [A] and the host sends the appropriate data byte (WD0) to be written. Again the chip acknowledges [A]. In case the host needs to write more data, a succeeding data byte will follow (WD1), acknowledged by the slave [A]. This sequence will be repeated until the host terminates the transfer with the stop condition [P].





- |      |                              |   |                     |
|------|------------------------------|---|---------------------|
| S:   | Start condition              |   |                     |
| SA:  | SX8654 Slave Address(6:0)    |  | From host to SX8654 |
| W:   | '0'                          |  | From SX8654 to host |
| A:   | Acknowledge                  |   |                     |
| CR:  | '00' + Register Address(5:0) |   |                     |
| WDn: | Write Data byte(7:0), 0...n  |   |                     |
| P:   | Stop condition               |   |                     |

Figure 50 – I2C Write Register

The register address increments automatically when successive data bytes (WD1...WDn) are supplied by the host.

**ADVANCED COMMUNICATIONS & SENSING**

The correct sampling of the screen by the chip and the host I2C bus traffic are events that might occur simultaneously. The chip will synchronize these events by the use of clock stretching if that is required. The stretching occurs directly after the last received command bit (see figure above).

**11.4 Read Register**

The I2C read register sequence is given in figure below. After the start condition [S], the chip slave address (SA) is sent, followed by an eighth bit (W='0') indicating a write. The chip then acknowledges [A] that it is being addressed, and the host responds with a CR byte consisting in '01' followed by the register address (RA). The chip acknowledges [A] and the host sends the repeated start condition [Sr]. Once again, the chip slave address (SA) is sent, followed by an eighth bit (R='1') indicating a read. The chip responds with an acknowledge [A] and the data byte (RD0). If the host needs to read more data it will acknowledge [A] and the chip will send the next data byte (RD1). This sequence will be repeated until the host terminates the transfer with a NACK [N] followed by a stop condition [P].

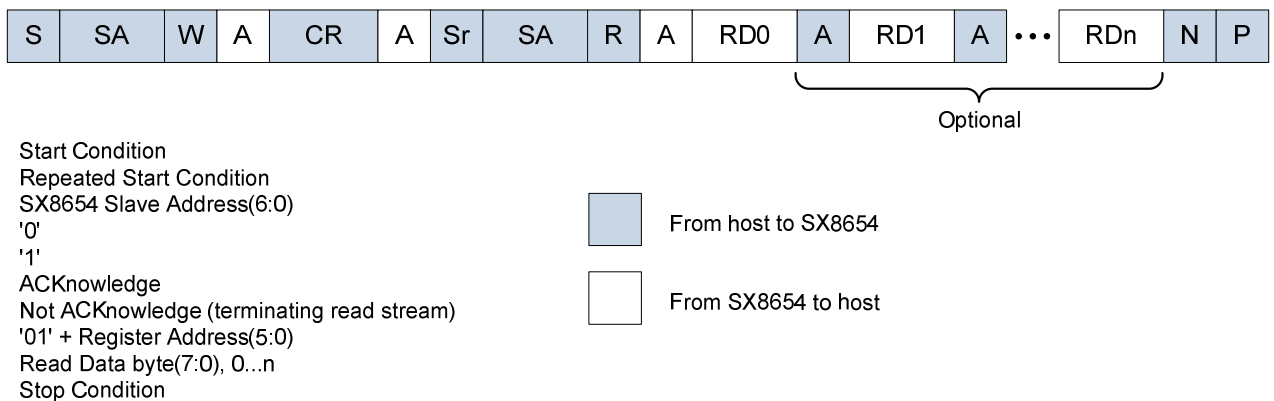


Figure 51 – I2C Read Register

The register address increments automatically when successive data bytes (RD1...RDn) are read by the host. The correct sampling of the screen by the chip and the host I2C bus traffic are events that might occur simultaneously. The chip will synchronize these events by the use of clock stretching if that is required. The stretching occurs directly after the last received command bit (see figure above).

**11.5 Write Command (Touchscreen Interface)**

The I2C write command sequence is given in figure below. After the start condition [S], the chip slave address (SA) is sent, followed by an eighth bit (W='0') indicating a write. The chip then acknowledges [A] that it is being addressed, and the host responds with a CR byte consisting in Command(7:0) (see table below). The chip acknowledges [A] and the host sends a stop [P].

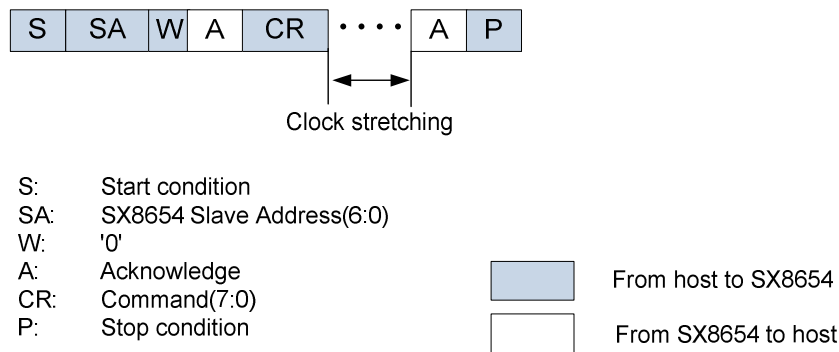


Figure 52 – I2C Write Command

The sampling of the screen by the chip and the host I2C bus traffic are events that might occur simultaneously. The chip will synchronize these events by the use of clock stretching if that is required. The stretching occurs directly after the last received command bit (see figure above).

**ADVANCED COMMUNICATIONS & SENSING**

Command	Command(7:0)					Function			
SELECT	1	0	1	0	X	Chan(2:0)			Select and bias channel.
CONVERT	1	0	1	1	X	Chan(2:0)			Convert channel.
MAN	1	1	0	0	X	X	X	X	Enter manual mode.
PENDET	1	1	0	1	X	X	X	X	Enter pen detect mode.
PENTRG	1	1	1	0	X	X	X	X	Enter pen trigger mode.

Table 9 : Command Codes

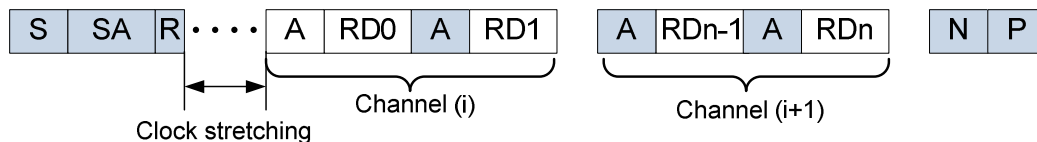
Channel	Chan(2:0)			Description
X	0	0	0	X channel
Y	0	0	1	Y channel
Z1	0	1	0	First channel for pressure measurement
Z2	0	1	1	Second channel for pressure measurement
SEQ	1	1	1	Channels enabled in RegChanMsk register

Table 10 : Channel Codes

**11.6 Read Channel (Touchscreen Interface)**

The I2C read channel sequence is given in figure below. After the start condition [S], the chip slave address (SA) is sent, followed by an eighth bit (R='1') indicating a read. The chip responds with an acknowledge [A] and the first data byte (RD0). The host sends an acknowledge [A] and the chip responds with the second data byte (RD1). If the host needs to read more channels, it will acknowledge [A] and the chip will send the next data byte. This sequence will be repeated until the host terminates with a NACK [N] followed immediately by a stop [P].

The channel data that can be read is defined by RegChanMsk, or the last convert command in manual mode. A maximum number of 8 data bytes can be read when all channels (X, Y, Z1, Z2) are activated in RegChanMsk. The STOP [P] (if following the last valid data) releases high the NIRQ line. All ADC related operations (touch conversion, proximity conversion, pen detection) are stopped as long as all valid channel data have not been read (ie as long as NIRQ is low).



- S: Start condition
- SA: SX8654 Slave Address(6:0)
- R: '1'
- A: Acknowledge
- N: Not Acknowledge (terminating read stream)
- RDn: Read Data byte(7:0), 0...n
- P: Stop condition

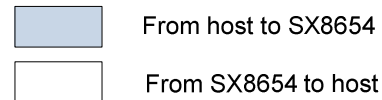


Figure 53 – I2C Read Channel

The sampling of the screen by the chip and the host I2C bus traffic are events that might occur simultaneously. The chip will synchronize these events by the use of clock stretching if that is required. The stretching occurs directly after the address and read bit have been sent for the I2C read channels command (see figure above).

The channel data is sent with the following order: X, Y, Z1, Z2. It is coded as described in figure below. Typical applications require only X and Y coordinates, thus only 4 bytes of data will be read in this case.

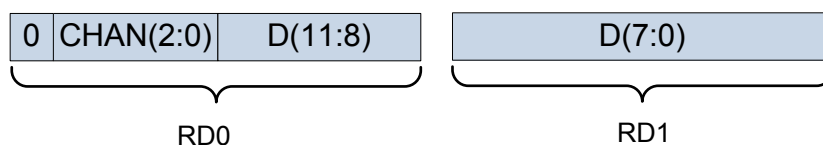


Figure 54 – Channel Data Format

**ADVANCED COMMUNICATIONS & SENSING**

The 3 bits CHAN(2:0) are defined in the previous table and show which channel data is referenced. The channel data D(11:0) is of unsigned format and corresponds to a value between 0 and 4095.

The chip will return 0xFFFF in case of invalid data; this occurs when:

- host tries to read channels which have not been converted. For example if the chip converts X and Y and the host tries to read X, Y, Z1 and Z2.
- a conversion has been done while the screen wasn't touched , i.e. pen up (not detected).

**ADVANCED COMMUNICATIONS & SENSING**
**12 REGISTERS DETAILED DESCRIPTION**

Address	Name	Default	Description
0x00	RegTouch0	0x00	Touchscreen Interface
0x01	RegTouch1	0x20	
0x02	RegTouch2	0x00	
0x03	RegTouch3	0x00	
0x04	RegChanMsk	0xC0	
0x05	RegHapt0	0x00	Haptics Interface and Temperature Sensor
0x06	RegHapt1	0x00	
0x07	RegHapt2	0x00	
0x08	RegHapt3	0x80	
0x09	RegHapt4	0x00	
0x0A	RegHapt5	0x00	Proximity Sensing Interface
0x0B	RegProx0	0x00	
0x0C	RegProx1	0x00	
0x0D	RegProx2	0x00	
0x0E	RegProx3	0x00	
0x0F	RegProx4	0x00	
0x10	RegProx5	0x00	
0x11	RegProx6	0x00	
0x12	RegProx7	0x00	
0x13	RegProx8	0x00	
0x14	RegProx9	0x00	
0x15	RegProx10	0x00	
0x16	RegProx11	0x00	
0x17	RegProx12	0x00	
0x18	RegProx13	0x00	
0x19	RegProx14	0x00	
0x1A	RegProx15	0x00	
0x1B	RegProx16	0x00	
0x1C	RegProx17	0x00	
0x1D	RegProx18	0x00	
0x1E	RegProx19	0x00	
0x1F	RegProx20	0x00	
0x20	RegProx21	0x01	
0x21	RegProx22	0x00	
0x22	RegIrqMsk	0x08	Interrupt and Chip Status
0x23	RegIrqSrc	0x00	
0x24	RegStat	0x00	
0x25	RegAux0	0x00	Auxiliary Functions
0x26	RegAux1	0x00	
0x3F	RegReset	0x00	Software Reset

*Table 11 : Registers Overview*
**NOTES:**

- 1) Addresses not listed above are reserved and should not be written.
- 2) **Reserved bits should be left to their default value unless otherwise specified.**
- 3) Proximity related registers/bits do not apply to SX8658.

**ADVANCED COMMUNICATIONS & SENSING**

Bits	Variable	Default	Description
7:4	TOUCHRATE	0000	<p>Defines the touch coordinates acquisition rate:</p> <p>0000 : OFF.  0001 : 10 cps  0010 : 20 cps  0011 : 40 cps  0100 : 60 cps  0101 : 80 cps  0110 : 100 cps  0111 : 200 cps  1000 : 300 cps  1001 : 400 cps  1010 : 500 cps  1011 : 1 kcps  1100 : 2 kcps  1101 : 3 kcps  1110 : 4 kcps  1111 : 5 kcps</p> <p>Values above assume typical FOSCL, else vary accordingly.</p>
3:0	POWDLY	0000	<p>Defines the bias settling time for each channel's first conversion:</p> <p>0000 : 0.5 us  0001 : 1.1 us  0010 : 2.2 us  0011 : 4.4 us  0100 : 8.9 us  0101 : 17.8 us  0110 : 35.5 us  0111 : 71.0 us  1000 : 142 us  1001 : 284 us  1010 : 568 us  1011 : 1.14 ms  1100 : 2.27 ms  1101 : 4.55 ms  1110 : 9.09 ms  1111 : 18.19 ms</p> <p>Values above assume typical FOSCH, else vary accordingly.</p>

*Table 12 : RegTouch0 (Addr 0x00)*

Bits	Variable	Default	Description
7:5	Reserved	001	
4	TSTYPE	0	<p>Defines the type of touchscreen:</p> <p>0 : 4-wire  1 : 5-wire</p>
3:2	RPNDT	00	<p>Defines the pen detection circuit's pull-up resistor value:</p> <p>00 : 114 kOhms  01 : 228 kOhms  10 : 57 kOhms  11 : 28 kOhms</p>

**ADVANCED COMMUNICATIONS & SENSING**

1:0	FILT	00	Defines the channel filtering algorithm:  00 : OFF (Nfilt = 1) 01 : 3 sample averaging (Nfilt = 3) 10 : 5 sample averaging (Nfilt = 5) 11 : 3 sample averaging after removal of extreme values (Nfilt = 7)
-----	------	----	---

*Table 13 : RegTouch1 (Addr 0x01)*

Bits	Variable	Default	Description
7:4	Reserved	0000	
3:0	SETDLY	0000	Defines the bias settling time for each channel's subsequent conversion (i.e. when filtering is enabled):  0000 : 0.5 us 0001 : 1.1 us 0010 : 2.2 us 0011 : 4.4 us 0100 : 8.9 us 0101 : 17.8 us 0110 : 35.5 us 0111 : 71.0 us 1000 : 142 us 1001 : 284 us 1010 : 568 us 1011 : 1.14 ms 1100 : 2.27 ms 1101 : 4.55 ms 1110 : 9.09 ms 1111 : 18.19 ms  Values above assume typical FOSCH, else vary accordingly.

*Table 14 : RegTouch2 (Addr 0x02)*

Bits	Variable	Default	Description
7:0	Reserved	0x00	

*Table 15 : RegTouch3 (Addr 0x03)*

Bits	Variable	Default	Description
7	XCONV	1	Enables X channel conversion: 0 : OFF 1 : ON
6	YCONV	1	Enables Y channel conversion: 0 : OFF 1 : ON
5	Z1CONV	0	Enables Z1 channel conversion: 0 : OFF 1 : ON
4	Z2CONV	0	Enables Z2 channel conversion: 0 : OFF 1 : ON
3:0	Reserved	0000	

*Table 16 : RegChanMsk (Addr 0x04)*

Bits	Variable	Default	Description
7	HAPTMODE	0	Defines the haptics mode/input: 0 : PWM 1 : I2C

**ADVANCED COMMUNICATIONS & SENSING**

6:5	HAPTTYPEEN	00	Defines the haptics load: 00 : OFF. Haptics block disabled. 01 : LRA 10 : ERM 11 : Reserved
4	HAPTRANGE	0	Defines MIN prescaler value: 0 : 128 1 : 256
3:0	HAPTGAIN	0000	Defines the haptics output gain: 0000 : 1 0001 : ~1.17 0010 : ~1.34 0011 : ~1.51 0100 : ~1.67 0101 : ~1.84 0110 : ~2.01 0111 : ~2.18 1000 : ~2.35 1001 : ~2.52 1010 : ~2.69 1011 : ~2.86 1100 : ~3.03 1101 : ~3.20 1110 : ~3.37 1111 : ~3.53  Exact formula is $1 + \text{Code} * 0.169$

*Table 17 : RegHapt0 (Addr 0x05)*

Bits	Variable	Default	Description
7:6	Reserved	00	
5:3	HAPTSQUELCH	000	Defines the Haptics squelch, i.e. the range of AmplitudeCode (HAPTAMP or MIN duty cycle equivalent, Cf. §6) which will generate a 0V output (VMOUT): 000 : OFF. No squelch. 001 : $-1 < \text{AmplitudeCode} < +1$ (ie. $\text{AmplitudeCode} = 0$ ) 010 : $-2 < \text{AmplitudeCode} < +2$ 011 : $-4 < \text{AmplitudeCode} < +4$ 100 : $-8 < \text{AmplitudeCode} < +8$ 101 : $-16 < \text{AmplitudeCode} < +16$ 110 : $-32 < \text{AmplitudeCode} < +32$ 111 : $-64 < \text{AmplitudeCode} < +64$
2	TEMPWRNIRQEDG	0	Enables TempWrnlrq to be generated when the chip temperature gets below the alarm threshold : 0 : OFF. TempWrnlrq generated only when the chip temperature gets above the alarm threshold. 1 : ON. TempWrnlrq generated both when the chip temperature gets above and below the alarm threshold.
1	TEMPALRMIRQEDG	0	Enables TempAlrmIrq to be generated when the chip temperature gets below the alarm threshold : 0 : OFF. TempAlrmIrq generated only when the chip temperature gets above the alarm threshold. 1 : ON. TempAlrmIrq generated both when the chip temperature gets above and below the alarm threshold.
0	TEMPALWAYSON	0	Enables the temperature monitoring even when no operation (touch, proximity, haptics) is enabled: 0 : OFF 1 : ON

*Table 18 : RegHapt1 (Addr 0x06)*

**ADVANCED COMMUNICATIONS & SENSING**

Bits	Variable	Default	Description
7:0	HAPTAMP	0x00	<p>Defines the haptics output polarity and level in I2C mode i.e. AmplitudeCode (Cf. §6) :</p> <p>0xFF : +127 (Max positive)</p> <p>...</p> <p>0x81 : +1</p> <p>0x80 : +0</p> <p>0x00 : -0</p> <p>0x01 : -1</p> <p>...</p> <p>0x7F : -127 (Max negative)</p> <p>HAPTAMP[7] gives the sign of AmplitudeCode (1=&gt;+;0=&gt;-) while HAPTAMP[6:0] give its magnitude.</p>

*Table 19 : RegHapt2 (Addr 0x07)*

Bits	Variable	Default	Description
7:5	HAPTBW	100	<p>Defines the haptics low-pass filter cut off frequency (Hz):</p> <p>000 : OFF. No filtering.</p> <p>001 : ~210 * SamplingFreq / 100</p> <p>010 : ~280 * SamplingFreq / 100</p> <p>011 : ~425 * SamplingFreq / 100</p> <p>100 : ~565 * SamplingFreq / 100</p> <p>101 : ~700 * SamplingFreq / 100</p> <p>110 : ~850 * SamplingFreq / 100</p> <p>111 : ~980 * SamplingFreq / 100</p> <p>SamplingFreq is VMOUT_Freq in LRA mode and MIN_Freq (PWM) or FOSCL (I2C) in ERM mode (Cf. §6)</p>
4	HAPTHZ	0	<p>Sets MOUTP and MOUTN to high impedance (HZ):</p> <p>0 : Normal</p> <p>1 : HZ</p>
3	HAPTSHORTPROT	0	<p>Disables short-circuit protection:</p> <p>0 : ON . A short-circuit event will automatically stop haptics operation.</p> <p>1 : OFF. A short-circuit event will not stop haptics operation.</p> <p>In both cases HAPTSHORTSTAT is still updated (and hence an interrupt can still be generated if needed)</p>
2:0	HAPTTIMERMSB	000	<p>Defines the haptics timer overflow value used to generate the LRA's 128 or 256 multiple frequency from MIN.</p>

*Table 20 : RegHapt3 (Addr 0x08)*

Bits	Variable	Default	Description
7:0	HAPTTIMERLSB	0x00	<p>Defines the haptics timer overflow value used to generate the LRA's 128 or 256 multiple frequency from MIN.</p> <p>HAPTTIMER[9:0] values below 8 (ie 0-7) are reserved.</p>

*Table 21 : RegHapt4 (Addr 0x09)*

Bits	Variable	Default	Description
7:0	Reserved	0x00	

*Table 22 : RegHapt5 (Addr 0x0A)*

Bits	Variable	Default	Description
7	PROXRAWFILTSEL	0	<p>Defines the proximity raw filtering range for PROXRAWFILT :</p> <p>0 : Fast</p> <p>1 : Slow</p>
6	PROXIRQSEL	0	<p>Defines the function of bits 5 of RegIrqMsk and RegIrqSrc.</p> <p>0 : ProxFar</p> <p>1 : ProxConvDone</p>

**ADVANCED COMMUNICATIONS & SENSING**

5:4	PROXHYST	00	Defines the proximity detection hysteresis : 00 : OFF 01 : 32 10 : 128 11 : 512
3:0	PROXSCANPERIOD	0000	Defines the proximity scan period : 0000 : OFF. Proximity sensing disabled 0001 : 1 / TOUCHRATE (Cf. RegTouch0) 0010 : 2 / TOUCHRATE 0011 : 4 / TOUCHRATE 0100 : 8 / TOUCHRATE 0101 : 16 / TOUCHRATE 0110 : 32 / TOUCHRATE 0111 : 64 / TOUCHRATE 1000 : 128 / TOUCHRATE 1001 : 256 / TOUCHRATE 1010 : 512 / TOUCHRATE 1011 : 1024 / TOUCHRATE 1100 : 2048 / TOUCHRATE 1101 : 4096 / TOUCHRATE 1110 : 8192 / TOUCHRATE 1111 : 16384 / TOUCHRATE

*Table 23 : RegProx0 (Addr 0x0B)*

Bits	Variable	Default	Description
7:0	PROXTHRESH	0x00	Defines the proximity detection threshold (for PROXSTAT update). Threshold = 16 x register value

*Table 24 : RegProx1 (Addr 0x0C)*

Bits	Variable	Default	Description
7:6	PROXCLOSEDEB	00	Defines the "Close" debounce (for PROXSTAT update): 00 : OFF 01 : 2 samples 10 : 4 samples 11 : 8 samples
5:4	PROXFARDEB	00	Defines the "Far" debounce (for PROXSTAT update): 00 : OFF 01 : 2 samples 10 : 4 samples 11 : 8 samples
3:0	PROXCOMPPRD	0000	Defines the periodic compensation : 0 : OFF Else : register value x 128 samples

*Table 25 : RegProx2 (Addr 0x0D)*

Bits	Variable	Default	Description
7:0	PROXSTUCK	0x00	Defines the stuck at timeout (ie max "Close" time before a compensation is automatically requested) : 0 : OFF Else : register value x 16 samples

*Table 26 : RegProx3 (Addr 0x0E)*

Bits	Variable	Default	Description
7:0	PROXAVGPOSTHRESH	0x00	Defines the average positive threshold (for compensation). Threshold = 8 x register value

*Table 27 : RegProx4 (Addr 0x0F)*

**ADVANCED COMMUNICATIONS & SENSING**

Bits	Variable	Default	Description
7:5	PROXAVGPOSDEB	000	Defines the average positive debounce (for compensation) : 000 : OFF 001 : 2 samples 010 : 4 samples 011 : 8 samples 100 : 16 samples 101 : 32 samples 110 : 64 samples 111 : 128 samples
4:2	PROXAVGPOSFILT	000	Defines the average positive filter coefficient : 000 : 0 (ie filtering OFF) 001 : 1 – 1/2 010 : 1 – 1/4 011 : 1 – 1/8 100 : 1 – 1/16 101 : 1 – 1/32 110 : 1 – 1/64 111 : 1 – 1/128
1:0	PROXRAWFILT	00	Defines the raw filter coefficient. If PROXRAWFILTSEL = 0 : 00 : 0 (ie filtering OFF) 01 : 1 – 1/2 10 : 1 – 1/4 11 : 1 – 1/8 If PROXRAWFILTSEL = 1 : 00 : 1 – 1/16 01 : 1 – 1/32 10 : 1 – 1/64 11 : 1 – 1/128

*Table 28 : RegProx5 (Addr 0x10)*

Bits	Variable	Default	Description
7:0	PROXAVGNEGTHRESH	0x00	Defines the average negative threshold (for compensation). Threshold = – 8 x register value

*Table 29 : RegProx6 (Addr 0x11)*

Bits	Variable	Default	Description
7:5	PROXAVGNEGDEB	000	Defines the average negative debounce (for compensation) : 000 : OFF 001 : 2 samples 010 : 4 samples 011 : 8 samples 100 : 16 samples 101 : 32 samples 110 : 64 samples 111 : 128 samples
4:2	PROXAVGNEGFILT	000	Defines the average negative filter coefficient : 000 : 0 (i.e. filtering OFF) 001 : 1 – 1/2 010 : 1 – 1/4 011 : 1 – 1/8 100 : 1 – 1/16 101 : 1 – 1/32 110 : 1 – 1/64 111 : 1 – 1/128
1	PROXHIGHIGHIM	0	Enables high noise immunity mode : 0 : OFF 1 : ON, at the expense of higher power consumption.
0	Reserved	0	

*Table 30 : RegProx7 (Addr 0x12)*

**ADVANCED COMMUNICATIONS & SENSING**

Bits	Variable	Default	Description
7:4	Reserved	0000	
3:0	PROXRWMSB	0000	Provides the proximity raw information for monitoring purposes. Signed, 2's complement format. Read-only (using PROXCONVDONE), do not write.

*Table 31 : RegProx8 (Addr 0x13)*

Bits	Variable	Default	Description
7:0	PROXRWLSB	0x00	Provides the proximity raw information for monitoring purposes. Signed, 2's complement format. Read-only (using PROXCONVDONE), do not write.

*Table 32 : RegProx9 (Addr 0x14)*

Bits	Variable	Default	Description
7:4	Reserved	0000	
3:0	PROXUSEFULMSB	0000	Provides the proximity information for monitoring purposes. Signed, 2's complement format. Read-only (using PROXCONVDONE), do not write.

*Table 33 : RegProx10 (Addr 0x15)*

Bits	Variable	Default	Description
7:0	PROXUSEFULLSB	0x00	Provides the proximity information for monitoring purposes. Signed, 2's complement format. Read-only (using PROXCONVDONE), do not write.

*Table 34 : RegProx11 (Addr 0x16)*

Bits	Variable	Default	Description
7:4	Reserved	0000	
3:0	PROXAVGMSB	0000	Provides the proximity average information for monitoring purposes. Signed, 2's complement format. Read-only (using PROXCONVDONE), do not write.

*Table 35 : RegProx12 (Addr 0x17)*

Bits	Variable	Default	Description
7:0	PROXAVGLSB	0x00	Provides the proximity average information for monitoring purposes. Signed, 2's complement format. Read-only (using PROXCONVDONE), do not write.

*Table 36 : RegProx13 (Addr 0x18)*

Bits	Variable	Default	Description
7:5	Reserved	0000	
4:0	PROXDIFFMSB	0000	Provides the proximity differential information for monitoring purposes. Signed, 2's complement format. Read-only (using PROXCONVDONE), do not write.

*Table 37 : RegProx14 (Addr 0x19)*

Bits	Variable	Default	Description
7:0	PROXDIFFLSB	0x00	Provides the proximity differential information for monitoring purposes. Signed, 2's complement format. Read-only (using PROXCONVDONE), do not write.

*Table 38 : RegProx15 (Addr 0x1A)*

Bits	Variable	Default	Description
7:0	PROXOFFSETMSB	0x00	Provides the proximity compensation offset information for monitoring purposes. Read-only (using PROXCONVDONE), do not write.

*Table 39 : RegProx16 (Addr 0x1B)*

**ADVANCED COMMUNICATIONS & SENSING**

Bits	Variable	Default	Description
7:0	PROXOFFSETLSB	0x00	Provides the proximity compensation offset information for monitoring purposes. Read-only (using PROXCONVDONE), do not write.

*Table 40 : RegProx17 (Addr 0x1C)*

Bits	Variable	Default	Description
7	Reserved	0	
6:4	PROXSENSITIVITY	000	Defines the sensitivity : 000 : 0 (Min) 001 : 1 010 : 2 011 : 3 100 : 4 101 : 5 110 : 6 111 : 7 (Max)
3:1	PROXFREQ	000	Defines the operating frequency : 010 : 64 kHz 011 : 90 kHz 100 : 112 kHz 101 : 150 kHz (recommended) Else : Reserved
0	Reserved	0	

*Table 41 : RegProx18 (Addr 0x1D)*

Bits	Variable	Default	Description
7:4	PROXSENSORCON	0000	Defines the proximity sensor connection, Cf. §5.1 : 0000 : None 0001 : AUX1/WIPER (5-wire TS) 0010 : AUX2 (external) 1000 : X (standard 4-wire TS) 1001 : Y (inverted 4-wire TS) Else : Reserved
3:0	PROXSHIELDCON	0000	Defines the proximity shield connection, Cf. §5.1 : 0000 : None 0011 : AUX3 (external) 1000 : X (inverted 4-wire TS) 1001 : Y (standard 4-wire TS or 5-wire TS) Else : Reserved

*Table 42 : RegProx19 (Addr 0x1E)*

Bits	Variable	Default	Description
7:6	Reserved	00	
5:3	PROXBOOST	000	Enables proximity boost mode (higher sensitivity) : 100 : ON 110 : OFF (recommended; compulsory when sensor is TS) Else : Reserved
2:0	Reserved	000	<b>Must be set to 100.</b>

*Table 43 : RegProx20 (Addr 0x1F)*

Bits	Variable	Default	Description
7:0	Reserved	0x01	<b>Must be set to 0x81.</b>

*Table 44 : RegProx21 (Addr 0x20)*

Bits	Variable	Default	Description
7:0	Reserved	0x00	

*Table 45 : RegProx22 (Addr 0x21)*

**ADVANCED COMMUNICATIONS & SENSING**

Bits	Variable	Default	Description
7	HAPTSHORTIRQEN	0	Enables the HaptShort interrupt. 0 : OFF 1 : ON
6	PROXCLOSEIRQEN	0	Enables the ProxClose interrupt. 0 : OFF 1 : ON
5	PROXFARIRQEN/ PROXCONVDONEIRQEN	0	Enables the ProxFar/ProxConvDone interrupt. Cf RegProx0[6] 0 : OFF 1 : ON
4	PROXCOMPDONEIRQEN	0	Enables the ProxCompDone interrupt. 0 : OFF 1 : ON
3	PENTOUCHIRQEN/ TOUCHCONVDONEIRQEN	1	Enables the PenTouch/TouchConvDone interrupt 0 : OFF 1 : ON
2	PENRELEASEIRQEN	0	Enables the PenRelease interrupt. 0 : OFF 1 : ON
1	TEMPWARNINGIRQEN	0	Enables the TempWarning interrupt. 0 : OFF 1 : ON
0	TEMPALARMIRQEN	0	Enables the TempAlarm interrupt. 0 : OFF 1 : ON

*Table 46 : RegIrqMsk (Addr 0x22)*

Bits	Variable	Default	Description
7	HAPTSHORTIRQ	0	Gives the HaptShort interrupt source status. (ie HAPTSHORTSTAT rising edge)
6	PROXCLOSEIRQ	0	Gives the ProxClose interrupt source status. (ie PROXSTAT rising edge)
5	PROXFARIRQ/ PROXCONVDONEIRQ	0	Gives the ProxFar (ie PROXSTAT falling edge), or ProxConvDone (ie CONVSTAT falling edge after proximity conversion) interrupt status depending on PROXIRQSEL .
4	PROXCOMPDONEIRQ	0	Gives the ProxCompDone interrupt source status. (ie PROXCOMPSTAT falling edge)
3	PENTOUCHIRQ/ TOUCHCONVDONEIRQ	0	Gives the PenTouch/TouchConvDone interrupt source status. (ie in PENDET mode -> PENSTAT rising edge, else -> CONVSTAT falling edge after touch conversion)
2	PENRELEASEIRQ	0	Gives the PenRelease interrupt source status. (ie PENSTAT falling edge)
1	TEMPWARNINGIRQ	0	Gives the TempWarning interrupt source status. (ie TEMPWARNINGSTAT rising/falling edge depending on TEMPWRNIRQEDG)
0	TEMPALARMIRQ	0	Gives the TempAlarm interrupt source status. (ie TEMPALARMSTAT rising/falling edge depending on TEMPALRMIRQEDG)

*Table 47 : RegIrqSrc (Addr 0x23)*

Bits	Variable	Default	Description
7	HAPTSHORTSTAT	0	Gives the haptics short-circuit instantaneous status : 0 : No short circuit is currently present 1 : A short circuit is currently present
6	RESETSTAT	0	Gives the reset latched status : 0 : No reset occurred 1 : A reset occurred This bit is cleared when RegStat is read.

**ADVANCED COMMUNICATIONS & SENSING**

5	PROXSTAT	0	<p>Gives the proximity instantaneous status: 0 : Far (or proximity sensing disabled) 1 : Close</p> <p>PROXSTAT (and PROXAVG) is automatically frozen to its current value if pen is down (whether TS or AUXi is the sensor) PROXSTAT is <b>NOT</b> frozen while haptics is running, if needed host can turn proximity sensing ON/OFF via PROXSCANPERIOD.</p>
4	PROXCOMPSTAT	0	<p>When read, this bit indicates gives the compensation instantaneous status : 0 : No compensation is currently pending 1 : A compensation is currently pending execution and/or completion</p> <p>When set to '1', triggers a compensation for next scan period.</p>
3	CONVSTAT	0	<p>Gives touch/proximity conversion instantaneous status : 0 : No touch or proximity conversion is currently running 1 : A touch or proximity conversion is currently running</p>
2	PENSTAT	0	<p>Gives the pen instantaneous status : 0 : Released/Up 1 : Touching/Down</p>
1	TEMPWARNINGSTAT	0	<p>Gives the temperature warning instantaneous status : 0 : Temperature is below warning threshold 1 : Temperature is above warning threshold</p>
0	TEMPALARMSTAT	0	<p>Gives the temperature alarm instantaneous status : 0 : Temperature is below alarm threshold 1 : Temperature is above alarm threshold</p>

*Table 48 : RegStat (Addr 0x24)*

Bits	Variable	Default	Description																
7	Reserved	0																	
6	AUX1DIGOUTEN	0	<p>Enables the digital output capability of AUX1 0 : OFF 1 : ON, Cf. AUX1DIGOUT.</p> <p>Bit is ignored if TSTYPE = 1 or PROXSENSORCON = 0001</p>																
5	AUX2DIGOUTEN	0	<p>Enables the digital output capability of AUX2 0 : OFF 1 : ON, Cf. AUX2DIGOUT.</p> <p>Bit is ignored if PROXSENSORCON = 0010</p>																
4	AUX3DIGOUTEN	0	<p>Enables the digital output capability of AUX3 0 : OFF 1 : ON, Cf. AUX3DIGOUT.</p> <p>Bit is ignored if TSTYPE = 1 or PROXSHIELDCON = 0011</p>																
3:0	AUX1DIGOUT	0000	<p>Defines the digital signal to output on AUX1 :</p> <table border="0"> <tr> <td>0000 : RegIrqSrc(0)</td> <td>1000 : RegStat(0)</td> </tr> <tr> <td>0001 : RegIrqSrc(1)</td> <td>1001 : RegStat(1)</td> </tr> <tr> <td>0010 : RegIrqSrc(2)</td> <td>1010 : RegStat(2)</td> </tr> <tr> <td>0011 : RegIrqSrc(3)</td> <td>1011 : RegStat(3)</td> </tr> <tr> <td>0100 : RegIrqSrc(4)</td> <td>1100 : RegStat(4)</td> </tr> <tr> <td>0101 : RegIrqSrc(5)</td> <td>1101 : RegStat(5)</td> </tr> <tr> <td>0110 : RegIrqSrc(6)</td> <td>1110 : RegStat(6)</td> </tr> <tr> <td>0111 : RegIrqSrc(7)</td> <td>1111 : RegStat(7)</td> </tr> </table>	0000 : RegIrqSrc(0)	1000 : RegStat(0)	0001 : RegIrqSrc(1)	1001 : RegStat(1)	0010 : RegIrqSrc(2)	1010 : RegStat(2)	0011 : RegIrqSrc(3)	1011 : RegStat(3)	0100 : RegIrqSrc(4)	1100 : RegStat(4)	0101 : RegIrqSrc(5)	1101 : RegStat(5)	0110 : RegIrqSrc(6)	1110 : RegStat(6)	0111 : RegIrqSrc(7)	1111 : RegStat(7)
0000 : RegIrqSrc(0)	1000 : RegStat(0)																		
0001 : RegIrqSrc(1)	1001 : RegStat(1)																		
0010 : RegIrqSrc(2)	1010 : RegStat(2)																		
0011 : RegIrqSrc(3)	1011 : RegStat(3)																		
0100 : RegIrqSrc(4)	1100 : RegStat(4)																		
0101 : RegIrqSrc(5)	1101 : RegStat(5)																		
0110 : RegIrqSrc(6)	1110 : RegStat(6)																		
0111 : RegIrqSrc(7)	1111 : RegStat(7)																		

*Table 49 : RegAux0 (Addr 0x25)*

**ADVANCED COMMUNICATIONS & SENSING**

Bits	Variable	Default	Description
7:4	AUX2DIGOUT	0000	Defines the digital signal to output on AUX2 : 0000 : RegLrqSrc(0)    1000 : RegStat(0) 0001 : RegLrqSrc(1)    1001 : RegStat(1) 0010 : RegLrqSrc(2)    1010 : RegStat(2) 0011 : RegLrqSrc(3)    1011 : RegStat(3) 0100 : RegLrqSrc(4)    1100 : RegStat(4) 0101 : RegLrqSrc(5)    1101 : RegStat(5) 0110 : RegLrqSrc(6)    1110 : RegStat(6) 0111 : RegLrqSrc(7)    1111 : RegStat(7)
3:0	AUX3DIGOUT	0000	Defines the digital signal to output on AUX3 : 0000 : RegLrqSrc(0)    1000 : RegStat(0) 0001 : RegLrqSrc(1)    1001 : RegStat(1) 0010 : RegLrqSrc(2)    1010 : RegStat(2) 0011 : RegLrqSrc(3)    1011 : RegStat(3) 0100 : RegLrqSrc(4)    1100 : RegStat(4) 0101 : RegLrqSrc(5)    1101 : RegStat(5) 0110 : RegLrqSrc(6)    1110 : RegStat(6) 0111 : RegLrqSrc(7)    1111 : RegStat(7)

*Table 50 : RegAux1 (Addr 0x26)*

Bits	Variable	Default	Description
7:0	SOFTRESET	0x00	Writing 0xDE will reset the chip and all registers to their default values.

*Table 51 : RegReset (Addr 0x3F)*

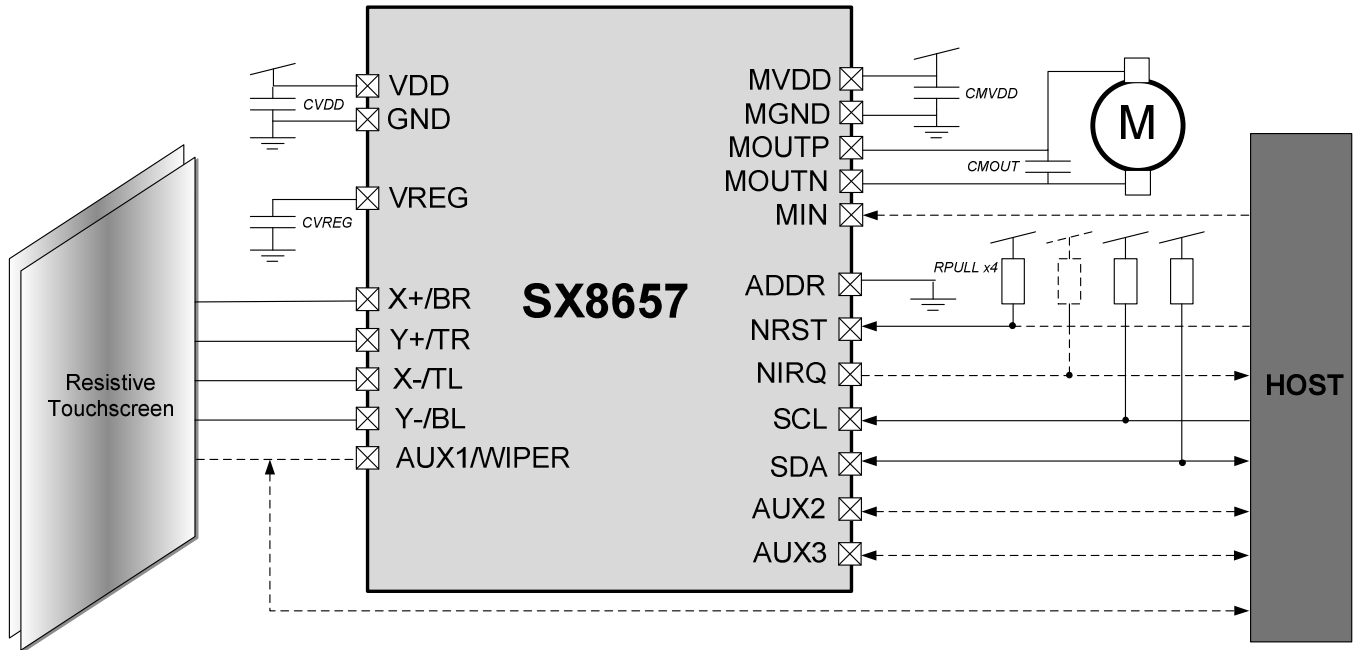
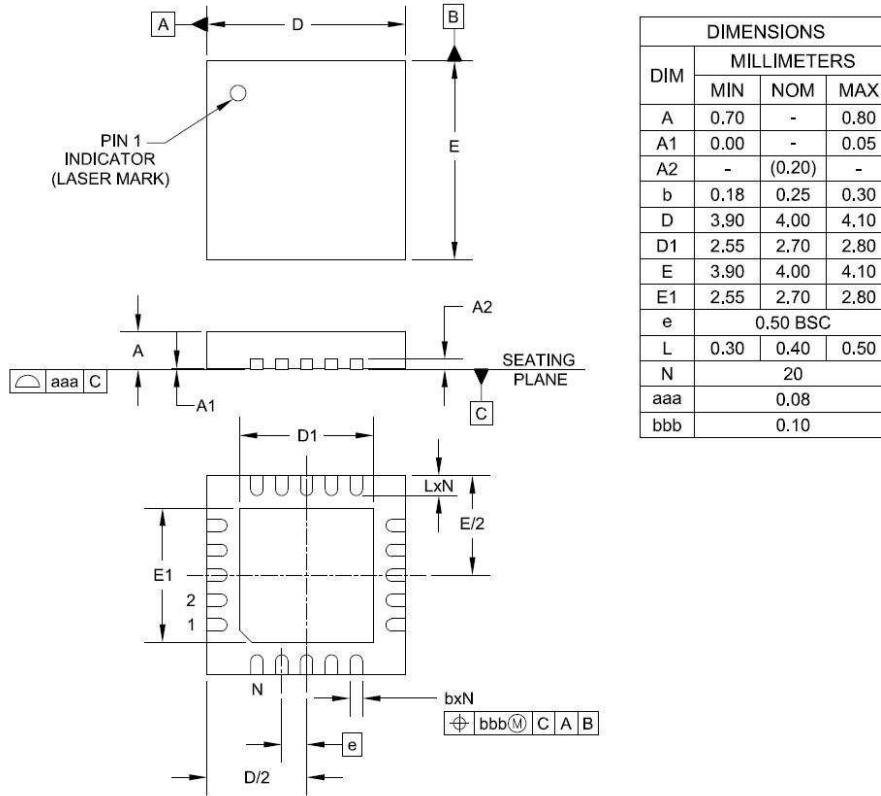
**13 APPLICATION INFORMATION**
**13.1 Typical Application Circuit**


Figure 55 – Typical Application Circuit

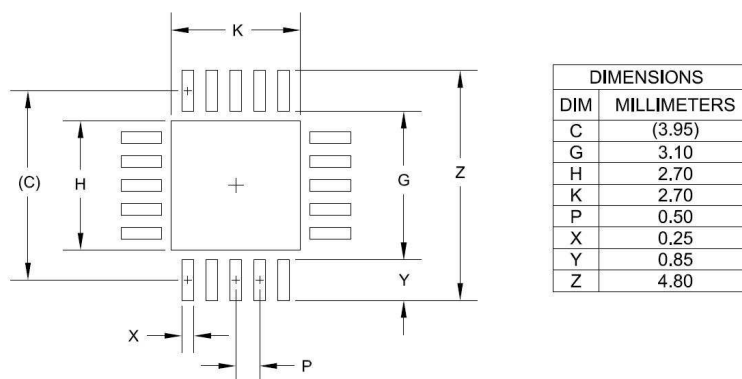
**13.2 External Components Recommended Values**

Symbol	Description	Note	Min	Typ.	Max	Unit
CVDD	Main supply decoupling capacitor		-	1	-	uF
CMVDD	Motor supply decoupling capacitor		-	10	-	uF
CVREG	Regulator decoupling capacitor	+/- 20%, ESR<1Ω	-	100	-	nF
RPULL	Host interface pull-ups	+/- 50%	-	10	-	kΩ
CTB	Proximity sensor-to-shield capacitance	-	-	<0.7	1.5	nF
RXY	Proximity sensor serial resistor	-	-	<1	1.5	kΩ
RMOT	Motor resistance	-	7.5	-	-	Ω
CMOUT	Motor output capacitor	-	-	1	-	uF

Table 52 : External Components Recommended Values

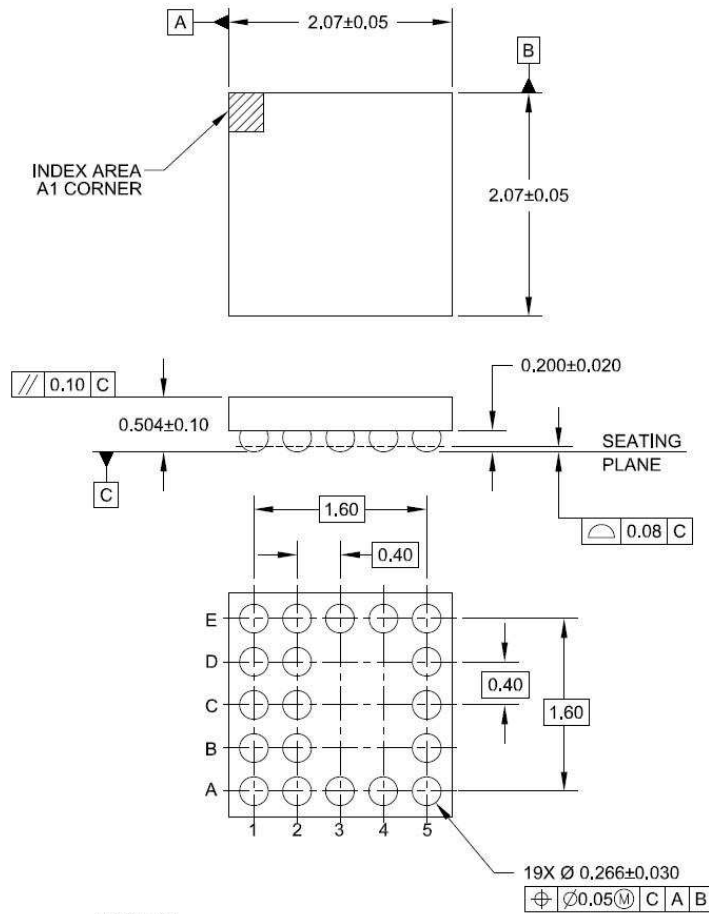
**14 PACKAGING INFORMATION**
**14.1 QFN Package**

**NOTES:**

1. CONTROLLING DIMENSIONS ARE IN MILLIMETERS (ANGLES IN DEGREES).
2. COPLANARITY APPLIES TO THE EXPOSED PAD AS WELL AS THE TERMINALS.

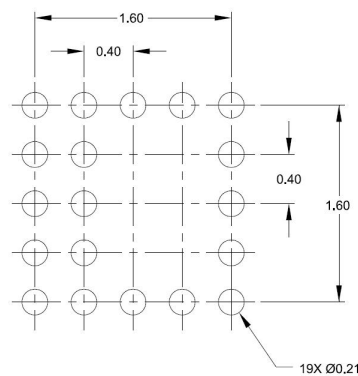
*Figure 56 - Outline Drawing - QFN*

**NOTES:**

1. CONTROLLING DIMENSIONS ARE IN MILLIMETERS (ANGLES IN DEGREES).
2. THIS LAND PATTERN IS FOR REFERENCE PURPOSES ONLY. CONSULT YOUR MANUFACTURING GROUP TO ENSURE YOUR COMPANY'S MANUFACTURING GUIDELINES ARE MET.
3. THERMAL VIAS IN THE LAND PATTERN OF THE EXPOSED PAD SHALL BE CONNECTED TO A SYSTEM GROUND PLANE. FAILURE TO DO SO MAY COMPROMISE THE THERMAL AND/OR FUNCTIONAL PERFORMANCE OF THE DEVICE.

*Figure 57 - Land Pattern - QFN*

**ADVANCED COMMUNICATIONS & SENSING**
**14.2 CSP Package**

**NOTES:**

1. CONTROLLING DIMENSIONS ARE IN MILLIMETERS

**Figure 58 - Outline Drawing - CSP**

**NOTES:**

1. CONTROLLING DIMENSIONS ARE IN MILLIMETERS
2. THIS LAND PATTERN IS FOR REFERENCE PURPOSES ONLY. CONSULT YOUR MANUFACTURING GROUP TO ENSURE YOUR COMPANY'S MANUFACTURING GUIDELINES ARE MET.

**Figure 59 - Land Pattern - CSP**

**ADVANCED COMMUNICATIONS & SENSING**

© Semtech 2011

All rights reserved. Reproduction in whole or in part is prohibited without the prior written consent of the copyright owner. The information presented in this document does not form part of any quotation or contract, is believed to be accurate and reliable and may be changed without notice. No liability will be accepted by the publisher for any consequence of its use. Publication thereof does not convey nor imply any license under patent or other industrial or intellectual property rights. Semtech assumes no responsibility or liability whatsoever for any failure or unexpected operation resulting from misuse, neglect improper installation, repair or improper handling or unusual physical or electrical stress including, but not limited to, exposure to parameters beyond the specified maximum ratings or operation outside the specified range.

SEMTECH PRODUCTS ARE NOT DESIGNED, INTENDED, AUTHORIZED OR WARRANTED TO BE SUITABLE FOR USE IN LIFE-SUPPORT APPLICATIONS, DEVICES OR SYSTEMS OR OTHER CRITICAL APPLICATIONS. INCLUSION OF SEMTECH PRODUCTS IN SUCH APPLICATIONS IS UNDERSTOOD TO BE UNDERTAKEN SOLELY AT THE CUSTOMER'S OWN RISK. Should a customer purchase or use Semtech products for any such unauthorized application, the customer shall indemnify and hold Semtech and its officers, employees, subsidiaries, affiliates, and distributors harmless against all claims, costs damages and attorney fees which could arise.

Notice: All referenced brands, product names, service names and trademarks are the property of their respective owners.

**Contact Information**





Semtech Corporation  
Advanced Communications and Sensing Products Division  
200 Flynn Road, Camarillo, CA 93012  
Phone: (805) 498-2111 Fax: (805) 498-3804

## Looking for pricing, stock, or lifecycle information?

Click below to explore more details on WIN SOURCE:

-  [View SX8658IWLTRT on WIN SOURCE](#)
-  [Semtech Corporation Information](#)

## Optimize Your Supply Chain with WIN SOURCE Solutions

-  Global Sourcing Solution
-  Obsolete Management
-  Cost Control Management
-  Shortage Management
-  Alternative Solution
-  Excess Inventory Management