



**THE DATASHEET OF
CYP15G0402DXB-BGXC**



Quad HOTLink II™ SERDES

Features

- Second-generation HOTLink® technology
- Compliant to multiple standards
 - Fibre Channel, Gigabit Ethernet (IEEE802.3z), ES-CON® and DVB-ASI
 - CYV15G0402DXB compliant to SMPTE 259M and SMPTE 292M
- Quad-channel transceiver operates from 195 to 1500 Mbps serial data rate
 - Aggregate throughput of 12 Gbps
- 10-bit unencoded data transport
- Selectable parity check/generate
- Four independent 10-bit channels with separate Clock and Data Recovery for each channel
- Selectable input clocking options
- MultiFrame™ Receive Framer
 - Comma or full K28.5 detect
 - Single or Multi-Byte framer for byte alignment
 - Low-latency option
- Synchronous LVTTTL parallel interface
- Internal phase-locked loops (PLLs) with no external PLL components
- Optional Phase Align Buffer in Transmit Path
- Differential PECL-compatible serial inputs
- Differential PECL-compatible serial outputs
 - Source matched for 50Ω transmission lines
 - No external resistors required
 - Signaling rate controlled edge rates
- Compatible with
 - Fiber-optic modules
 - Copper cables

- Circuit board traces
- JTAG boundary scan
- Built-In Self-Test (BIST) for at-speed link testing
- Per-channel Link Quality Indicator
 - Analog signal detect
 - Digital signal detect
- Low-power 2.5W @3.3V typical
- Single 3.3V supply
- 256-ball thermally enhanced BGA
- Pb-Free package option available
- 0.25μ BiCMOS technology

Functional Description

The CYP(V)15G0402DXB^[1] Quad HOTLink II™ SERDES is a point-to-point communications building block allowing the transfer of preencoded data over high-speed serial links (optical fiber, balanced, and unbalanced copper transmission lines) at signaling speeds ranging from 195 to 1500 Mbaud per serial link.

Each transmit channel accepts preencoded 10-bit transmission characters in an Input Register, serializes each character, and drives it out a PECL-compatible differential line driver. Each receive channel accepts a serial data stream at a differential line receiver, deserializes the stream into 10-bit characters, optionally frames these characters to the proper 10-bit character boundaries and presents these characters to an Output register. *Figure 1* illustrates typical connections between independent systems and a CYP(V)15G0402DXB.

The CYV15G0402DXB satisfies the SMPTE-259M and SMPTE-292M compliance as per the EG34-1999 Pathological Test Requirements.

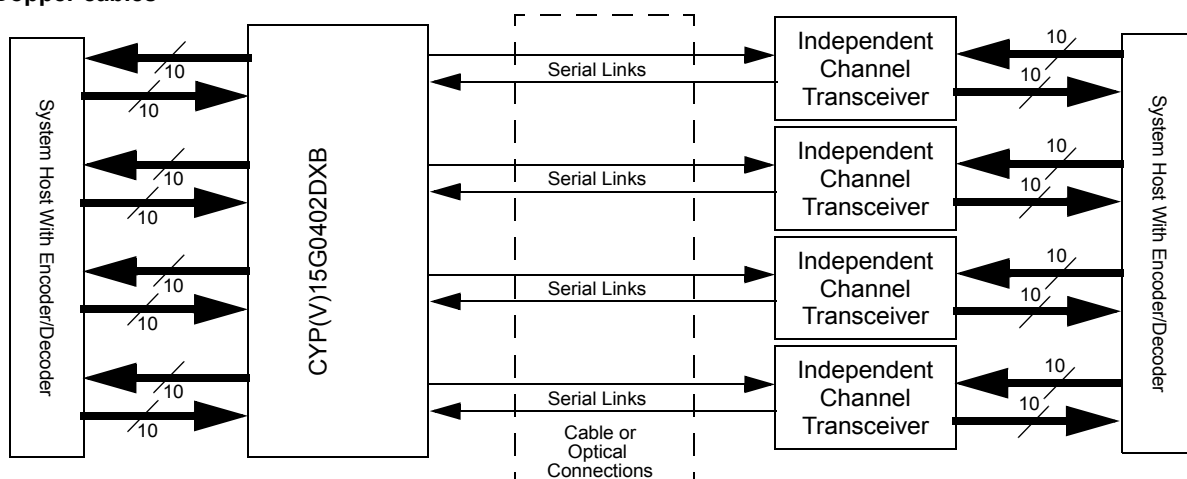

Figure 1. CYP(V)15G0402DXB HOTLink II™ System Connections

Note:

1. CYV15G0402DXB refers to SMPTE 259M and SMPTE 292M compliant devices. CYP15G0402DXB refers to devices that are not compliant to SMPTE 259M and SMPTE 292M pathological test requirements. CYP(V)15G0402DXB refers to both devices.

As a second-generation HOTLink device, the CYP(V)15G0402DXB extends the HOTLink family to faster data rates, while maintaining serial link compatibility (data, command and BIST) with other HOTLink devices. The transmit (TX) section of the CYP(V)15G0402DXB Quad HOTLink II SERDES consists of four ten bit wide channels that accept a preencoded character on every clock cycle. Transmission characters are passed from the Transmit Input Register to a Serializer. The serialized characters are output from a differential transmission line driver at a bit-rate of 10 or 20 times the input reference clock.

The receive (RX) section of the CYP(V)15G0402DXB Quad HOTLink II SERDES consists of four ten bit wide channels. Each channel accepts a serial bit-stream from a PECL-compatible differential line receiver and, using a completely integrated PLL Clock Synchronizer, recovers the timing information necessary for data reconstruction. Each recovered bit-stream is deserialized and framed into characters. Recovered characters are then passed to the receiver output register, along with a recovered character clock.

The parallel input interface may be configured for numerous forms of clocking to provide the high flexibility in system architecture.

Each transmit and receive channel contains an independent BIST pattern generator and checker. This BIST hardware allows at-speed testing of the interface data path.

HOTLink II devices are ideal for a variety of applications where parallel interfaces can be replaced with high-speed, point-to-point serial links. Some applications include interconnecting backplanes on switches, routers, servers and video transmission systems.

The CYV15G0402DXB is verified by testing to be compliant to all the pathological test patterns documented in SMPTE EG34-1999, for both the SMPTE 259M and 292M signaling rates. The tests ensure that the receiver recovers data with no errors for the following patterns:

1. Repetitions of 20 ones and 20 zeros.
2. Single burst of 44 ones or 44 zeros.
3. Repetitions of 19 ones followed by 1 zero or 19 zeros followed by 1 one.

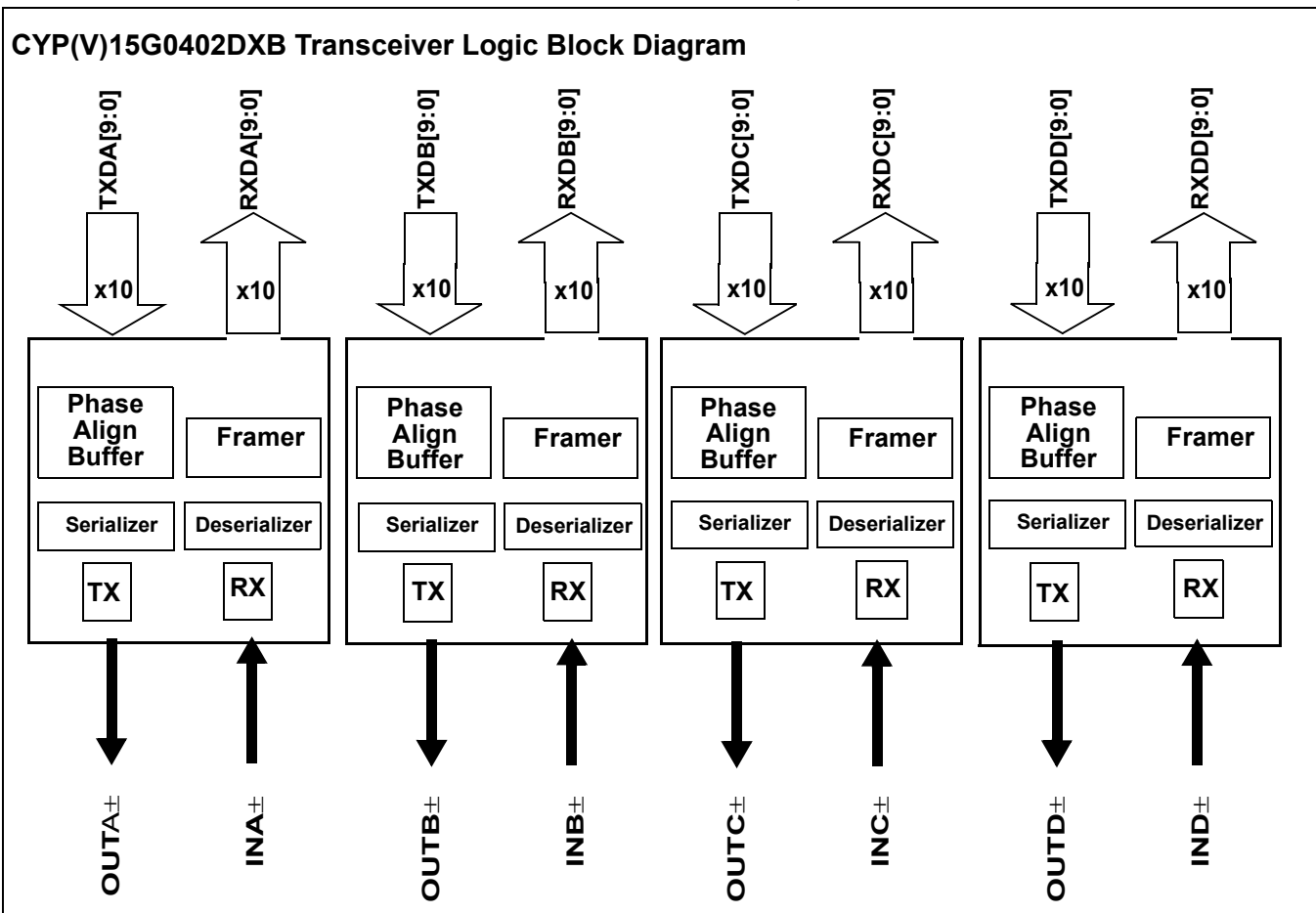

Transmit Path Block Diagram

--▷ = Internal Signal

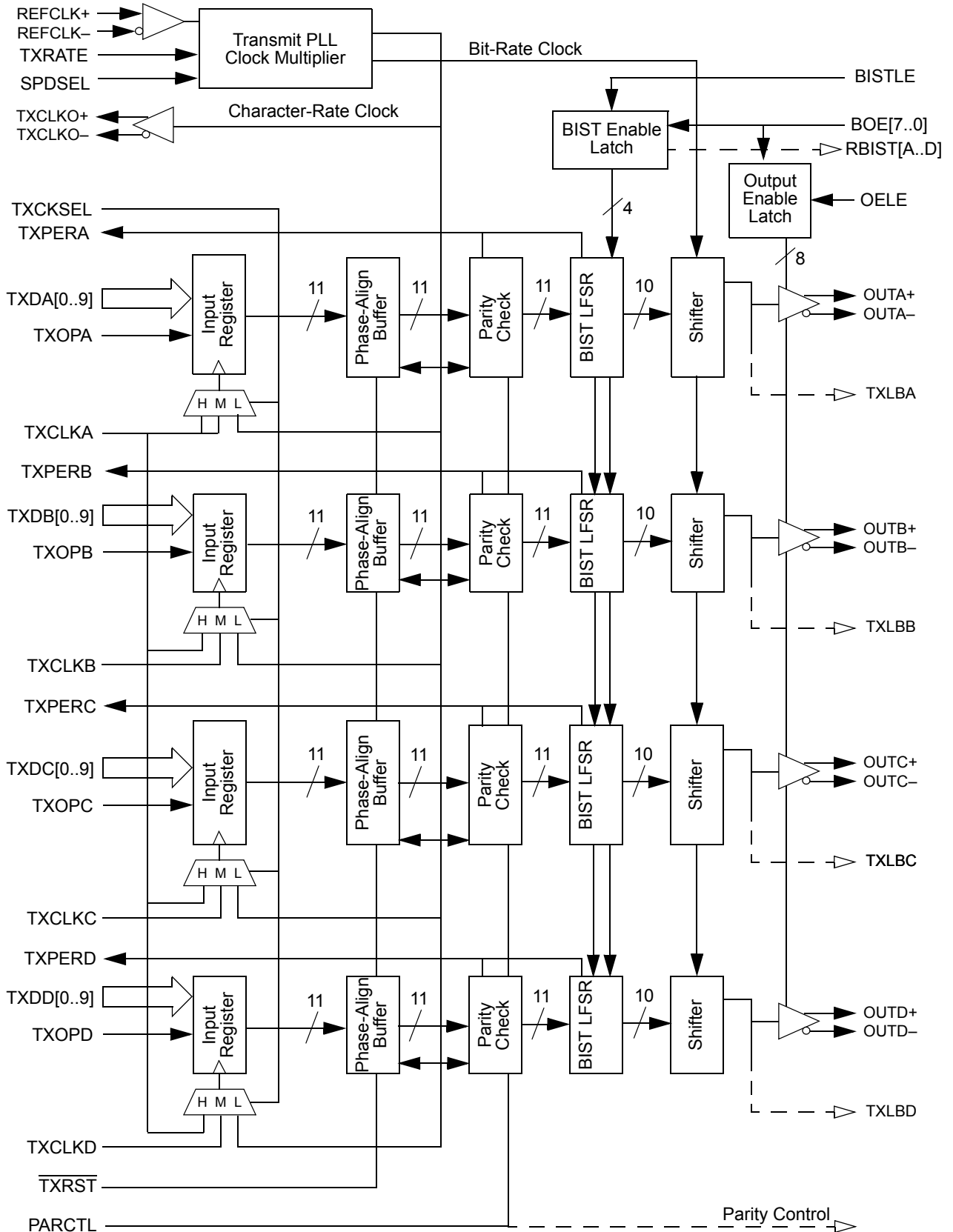

Receive Path Block Diagram

--> = Internal Signal

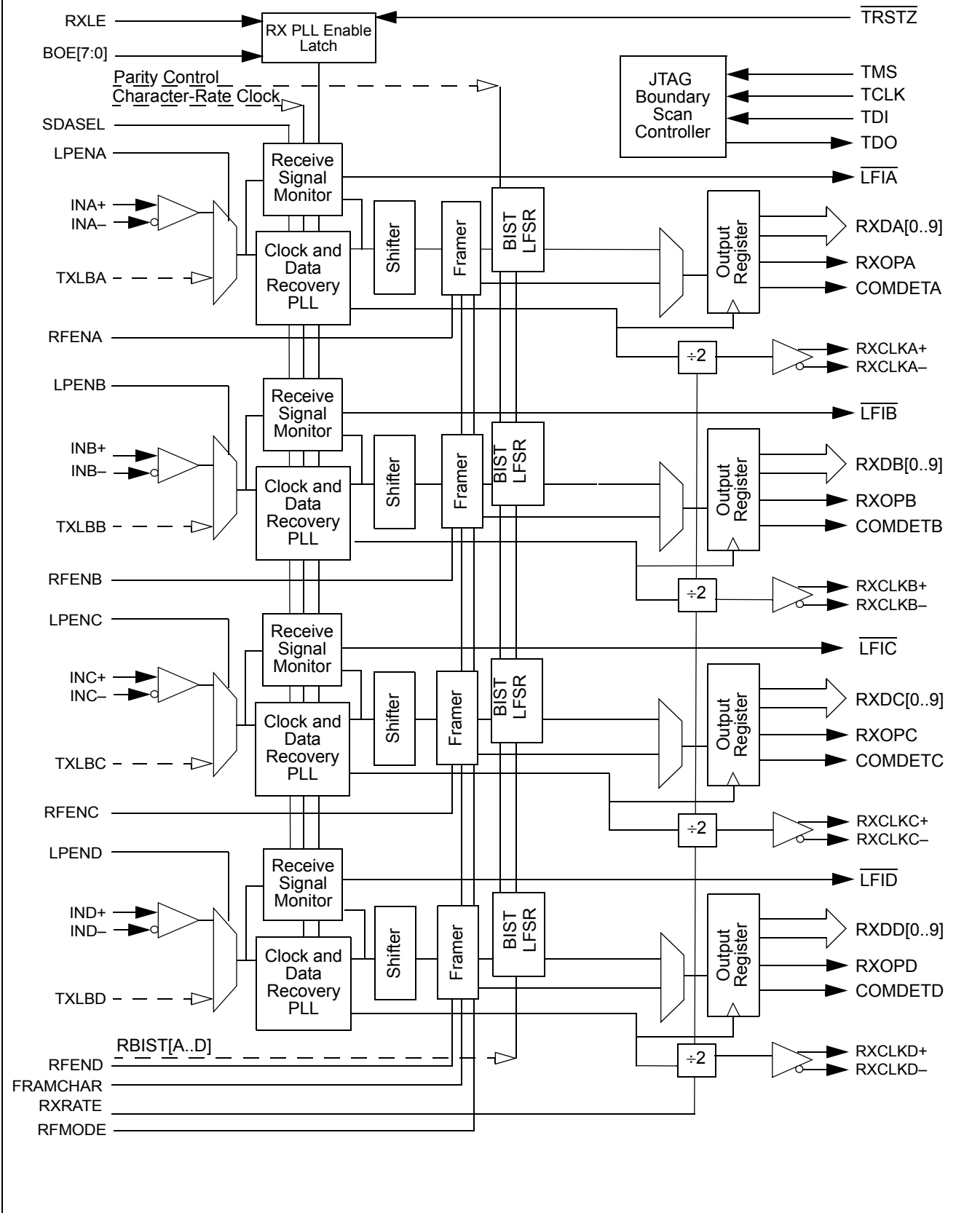



Pin Configuration (Top View)^[2]

	1	2	3	4	5	6	7	8	9	10	11	12	13	14	15	16	17	18	19	20
A	INC-	OUTC-	N/C	N/C	V _{CC}	IND-	OUTD-	GND	N/C	N/C	INA-	OUTA-	GND	N/C	N/C	V _{CC}	INB-	OUTB-	N/C	N/C
B	INC+	OUTC+	N/C	N/C	V _{CC}	IND+	OUTD+	GND	N/C	N/C	INA+	OUTA+	GND	N/C	N/C	V _{CC}	INB+	OUTB+	N/C	N/C
C	TDI	TMS	LPENC	LPENB	V _{CC}	PARCTL	SDASEL	GND	BOE[7]	BOE[5]	BOE[3]	BOE[1]	GND	GND	GND	V _{CC}	TXRATE	RXRATE	N/C	TDO
D	TCLK	TRSTZ	LPEND	LPENA	V _{CC}	RF MODE	SPD SEL	GND	BOE[6]	BOE[4]	BOE[2]	BOE[0]	GND	GND	GND	V _{CC}	N/C	RXLE	N/C	N/C
E	V _{CC}	V _{CC}	V _{CC}	V _{CC}													V _{CC}	V _{CC}	V _{CC}	V _{CC}
F	TXPER C	TXOP C	TXDC [0]	N/C													BISTLE	RXDB [0]	RXOP B	RXDB [1]
G	TXDC [7]	TXCKSEL	TXDC [4]	TXDC [1]													GND	OELE	FRAM CHAR	RXDB [3]
H	GND	GND	GND	GND													GND	GND	GND	GND
J	TXDC [9]	TXDC [5]	TXDC [2]	TXDC [3]													COMDET B	RXDB [2]	RXDB [7]	RXDB [4]
K	RXDC [4]	RXCLK C-	TXDC [8]	LFIC													RXDB [5]	RXDB [6]	RXDB [8]	RXCLKB +
L	RXDC [5]	RXCLK C+	TXCLK C	TXDC [6]													RXDB [8]	LFIB	RXCLK B-	TXDB [6]
M	RXDC [6]	RXDC [7]	RXDC [9]	RXDC [8]													TXDB [9]	TXDB [8]	TXDB [7]	TXCLK B
N	GND	GND	GND	GND													GND	GND	GND	GND
P	RXDC [3]	RXDC [2]	RXDC [1]	RXDC [0]													TXDB [5]	TXDB [4]	TXDB [3]	TXDB [2]
R	COMDET C	RXOP C	TXPER D	TXOP D													TXDB [1]	TXDB [0]	TXOP B	TXPER B
T	V _{CC}	V _{CC}	V _{CC}	V _{CC}													V _{CC}	V _{CC}	V _{CC}	V _{CC}
U	TXDD [0]	TXDD [1]	TXDD [2]	TXDD [9]	V _{CC}	RXDD [4]	RXDD [3]	GND	RXOP D	RFEN C	REFCLK -	TXDA [1]	GND	TXDA [4]	TXDA [8]	V _{CC}	RXDA [4]	RXOPA	COMDET A	RXDA [0]
V	TXDD [3]	TXDD [4]	TXDD [8]	RXDD [8]	V _{CC}	RXDD [5]	RXDD [1]	GND	COMDET D	RFEN D	REFCLK +	RFEN B	GND	TXDA [3]	TXDA [7]	V _{CC}	RXDA [9]	RXDA [5]	RXDA [2]	RXDA [1]
W	TXDD [5]	TXDD [7]	LFID	RXCLK D-	V _{CC}	RXDD [6]	RXDD [0]	GND	TXCLKO -	TXRST	TXOPA	RFEN A	GND	TXDA [2]	TXDA [6]	V _{CC}	LFIA	RXCLKA -	RXDA [9]	RXDA [3]
Y	TXDD [6]	TXCLK D	RXDD [9]	RXCLK D+	V _{CC}	RXDD [7]	RXDD [2]	GND	TXCLKO +	N/C	TXCLK A	TXPER A	GND	TXDA [0]	TXDA [5]	V _{CC}	TXDA [9]	RXCLKA +	RXDA [8]	RXDA [7]

Note:

2. N/C = Do Not Connect



Pin Configuration (Bottom View)^[3]

	20	19	18	17	16	15	14	13	12	11	10	9	8	7	6	5	4	3	2	1
A	N/C	NC	OUTB-	INB-	V _{CC}	N/C	N/C	GND	OUTA-	INA-	NC	NC	GND	OUTD-	IND-	V _{CC}	NC	NC	OUTC-	INC-
B	NC	NC	OUTB+	INB+	V _{CC}	N/C	N/C	GND	OUTA+	INA+	NC	NC	GND	OUTD+	IND+	V _{CC}	NC	NC	OUTC+	INC+
C	TDO	NC	RXRATE	TXRATE	V _{CC}	GND	GND	GND	BOE[1]	BOE[3]	BOE[5]	BOE[7]	GND	SDASEL	PARCTL	V _{CC}	LPENB	LPENC	TMS	TDI
D	NC	NC	RXLE	NC	V _{CC}	GND	GND	GND	BOE[0]	BOE[2]	BOE[4]	BOE[6]	GND	SPD SEL	RF MODE	V _{CC}	LPENA	LPEND	TRSTZ	TCLK
E	V _{CC}	V _{CC}	V _{CC}	V _{CC}													V _{CC}	V _{CC}	V _{CC}	V _{CC}
F	RXDB [1]	RXOP B	RXDB [0]	BISTLE													NC	TXDC [0]	TXOP C	TXPER C
G	RXDB [3]	FRAM CHAR	OELE	GND													TXDC [1]	TXDC [4]	TXCK SEL	TXDC [7]
H	GND	GND	GND	GND													GND	GND	GND	GND
J	RXDB [4]	RXDB [7]	RXDB [2]	COMDET B													TXDC [3]	TXDC [2]	TXDC [5]	TXDC [6]
K	RXCLKB +	RXDB [9]	RXDB [8]	RXDB [5]													LFIC	TXDC [8]	RXCLK C-	RXDC [4]
L	TXDB [6]	RXCLK B-	LFIB	RXDB [8]													TXDC [6]	TXCLK C	RXCLK C+	RXDC [5]
M	TXCLK B	TXDB [7]	TXDB [8]	TXDB [9]													RXDC [8]	RXDC [9]	RXDC [7]	RXDC [6]
N	GND	GND	GND	GND													GND	GND	GND	GND
P	TXDB [2]	TXDB [3]	TXDB [4]	TXDB [5]													RXDC [0]	RXDC [1]	RXDC [2]	RXDC [3]
R	TXPERB	TXOPB	TXDB [0]	TXDB [1]													TXOP D	TXPER D	RXOP C	COMDET C
T	V _{CC}	V _{CC}	V _{CC}	V _{CC}													V _{CC}	V _{CC}	V _{CC}	V _{CC}
U	RXDA [0]	COMDET A	RXOP A	RXDA [4]	V _{CC}	TXDA [8]	TXDA [4]	GND	TXDA [1]	REFCLK -	RFEN C	RXOP D	GND	RXDD [3]	RXDD [4]	V _{CC}	TXDD [9]	TXDD [2]	TXDD [1]	TXDD [0]
V	RXDA [1]	RXDA [2]	RXDA [5]	RXDA [9]	V _{CC}	TXDA [7]	TXDA [3]	GND	RFEN B	REFCLK +	RFEN D	COMDET D	GND	RXDD [1]	RXDD [5]	V _{CC}	RXDD [8]	TXDD [8]	TXDD [4]	TXDD [3]
W	RXDA [3]	RXDA [6]	RXCLKA -	LFIA	V _{CC}	TXDA [6]	TXDA [2]	GND	RFEN A	TXOP A	TXRST	TXCLKO -	GND	RXDD [0]	RXDD [9]	V _{CC}	RXCLKD -	LFID	TXDD [7]	TXDD [5]
Y	RXDA [7]	RXDA [8]	RXCLKA +	TXDA [9]	V _{CC}	TXDA [5]	TXDA [0]	GND	TXPER A	TXCLKA	NC	TXCLKO +	GND	RXDD [2]	RXDD [7]	V _{CC}	RXCLKD +	RXDD [9]	TXCLK D	TXDD [6]

Note:

3. N/C = Do Not Connect

Pin Descriptions CYP(V)15G0402DXB Quad HOTLink II™ SERDES

Name	I/O Characteristics	Signal Description
Transmit Path Data Signals		
TXPERA TXPERB TXPERC TXPERD	LVTTTL Output, changes relative to REFCLK↑ ^[4]	<p>Transmit Path Parity Error. Active HIGH. Asserted (HIGH) if parity checking is enabled and a parity error is detected at the shifter. This output is HIGH for one transmit character clock period to indicate detection of a parity error in the character presented to the shifter.</p> <p>If a parity error is detected, the character in error is replaced with the 10-bit character, 1001111000, to force a corresponding bad-character detection at the remote end of the link. This replacement takes place only when parity checking is enabled (PARCTL ≠ LOW).</p> <p>When BIST is enabled for the specific transmit channel, BIST progress is presented on these outputs. Once every 511 character times, the associated TXPERx signal will pulse HIGH for one transmit-character clock period to indicate a complete pass through the BIST sequence.</p> <p>These outputs also provide indication of a transmit Phase-Align Buffer underflow or overflow. When the transmit Phase-Align Buffers are enabled (TXCKSEL ≠ LOW, or TXCKSEL = LOW and TXRATE = HIGH), if an underflow or overflow condition is detected, TXPERx for the channel in error is asserted and remains asserted until either an atomic Word Sync Sequence is transmitted or TXRST is sampled LOW to re-center the transmit Phase-Align Buffers.</p>
TXDA[9:0] TXDB[9:0] TXDC[9:0] TXDD[9:0]	LVTTTL Input, synchronous, sampled by the respective TXCLKx↑ or REFCLK↑ ^[4]	<p>Transmit Data Inputs. These inputs are captured on the rising edge of the transmit interface clock as selected by TXCKSEL and passed to the transmit shifter.</p> <p>TXDx[9:0] specify the specific transmission character to be sent.</p>
TXOPA TXOPB TXOPC TXOPD	LVTTTL Input, synchronous, sampled by the respective TXCLKx↑ or REFCLK↑ ^[4]	<p>Transmit Path Odd Parity. When parity checking is enabled (PARCTL ≠ LOW), the ODD parity captured at these inputs is XORed with the bits on the associated TXDx bus to verify the integrity of the captured character.</p>
Transmit Path Clock and Control		
TXCLKO±	LVTTTL Output	<p>Transmit Clock Output. This true and complement clock is synthesized by the transmit PLL and is synchronous to the internal transmit character clock. It has the same frequency as REFCLK (when TXRATE = LOW), or twice the frequency of REFCLK (when TXRATE = HIGH). This output clock has no direct phase relationship to REFCLK.</p>
TXCKSEL	Three-level Select ^[5] Static Control Input	<p>Transmit Clock Select.</p> <p>Selects the clock source used to write data into the transmit Input Register of the transmit channel(s)</p> <p>When LOW, all four input registers are clocked by REFCLK↑.</p> <p>When TXCKSEL is MID, TXCLKx↑ is used as the input register clock for the associated TXDx[9:0] and TXOPx.</p> <p>When HIGH, TXCLKA↑ is used to clock data into the Input Register for all channels.</p> <p>When TXCKSEL = MID or HIGH (TXCLKx or TXCLKA selected to clock input register), TXRATE = HIGH (Half-rate REFCLK) is an invalid mode of operation.</p>
TXCLKA TXCLKB TXCLKC TXCLKD	LVTTTL Clock Input asynchronous, internal pull-up	<p>Transmit Path Input Clocks. These inputs are only used when TXCKSEL ≠ LOW.</p> <p>These clocks must be frequency-coherent to REFCLK, but may be offset in phase.</p> <p>The internal <u>operating</u> phase of each input clock (<u>relative</u> to REFCLK or TXCLKO±) is adjusted when TXRST = LOW and locked when TXRST = HIGH.</p>

Notes:

- When REFCLK is configured for half-rate operation (TXRATE = HIGH), these inputs are sampled (or the outputs change) relative to both the rising and falling edges of REFCLK
- Three-level select inputs are used for static configuration. They are ternary (not binary) inputs that make use of non-standard logic levels of LOW, MID, and HIGH. The LOW level is usually implemented by direct connection to V_{SS} (ground). The HIGH level is usually implemented by direct connection to V_{CC}. When not connected or allowed to float, a three-level select input will self-bias to the MID level.

Pin Descriptions CYP(V)15G0402DXB Quad HOTLink II™ SERDES (continued)

Name	I/O Characteristics	Signal Description
TXRATE	LVTTL Input, asynchronous, internal pull-up	<p>Transmit PLL Clock Rate Select. When TXRATE = HIGH, the Transmit PLL multiplies REFCLK by 20 to generate the serial bit-rate clock. When TXRATE = LOW, the transmit PLL multiplies REFCLK by 10 to generate the serial bit-rate clock. See <i>Table 3</i> for a list of operating serial rates.</p> <p>When TXCKSEL = MID or HIGH (TXCLKx or TXCLKA selected to clock input register), TXRATE = HIGH (Half-rate REFCLK) is an invalid mode of operation.</p>
TXRST	LVTTL Input, asynchronous, internal pull-up, sampled by REFCLK↑ ^[4]	<p>Transmit Clock Phase Reset. Active LOW. When sampled LOW, the transmit Phase-align Buffers are allowed to adjust their data-transfer timing (relative to the selected input clock) to <u>allow</u> clean transfer of data from the Input Register to the Transmit Shifter. When TXRST is sampled HIGH, the internal phase relationship between the associated TXCLKx and the internal character-rate clock is fixed and the device operates normally.</p> <p>When configured for half-rate REFCLK sampling of the transmit character stream (TXCKSEL = LOW and TXRATE = HIGH), assertion of TXRST is only used to clear Phase-align buffer faults caused by highly asymmetric REFCLK periods or REFCLKs with excessive cycle-to-cycle jitter. During this alignment period, one or more characters may be added to or lost from <u>all the</u> associated transmit paths as the transmit Phase-align Buffers are adjusted. TXRST must be sampled LOW by a minimum of two consecutive rising edges of REFCLK to ensure the reset operation is initiated correctly on all channels. This input is ignored when both TXCKSEL and TXRATE are LOW, since the phase align buffer is bypassed. In all other configurations, TXRST should be <u>asserted</u> during device initialization to ensure proper operation of the Phase-align buffer. TXRST should be asserted after the assertion and deassertion of TRSTZ, after the presence of a valid TXCLKx and after allowing enough time for the TXPLL to lock to the reference clock (as specified by parameter t_{TXLOCK}).</p>
Receive Path Data Signals		
RXDA[9:0] RXDB[9:0] RXDC[9:0] RXDD[9:0]	LVTTL Output, synchronous to the selected RXCLKx↑	Receive Data Output. These outputs change following the rising edge of the selected receive interface clock.
COMDETA COMDETB COMDETC COMDETD	LVTTL Output, synchronous to the selected RXCLKx↑	Frame Character Detected. COMDETx = HIGH indicates the presence of a Framing character in that Output Register.
RXOPA RXOPB RXOPC RXOPD	Three-state, LVTTL Output, synchronous to the selected RXCLKx↑ output	Receive Path Odd Parity. When parity generation is enabled (PARCTL ≠ LOW), the parity output at these pins is valid for the data on the associated RXDx bus bits. When parity generation is disabled (PARCTL = LOW) these output drivers are disabled (High-Z).
Receive Path Clock and Clock Control		
RFENA RFENB RFENC RFEND	LVTTL Input, asynchronous, internal pull-down	Reframe Enable. Active HIGH. When HIGH the framer for the associated channel is enabled to frame as per the presently enabled framing mode and selected framing character.
RXRATE	LVTTL Input Static Control Input	<p>Receive Clock Rate Select. When LOW, the RXCLKx± recovered clock outputs are complementary clocks operating at the recovered character rate. Data for the associated receive channels should be latched on the rising edge of RXCLKx+ or falling edge of RXCLKx-.</p> <p>When HIGH, the RXCLKx± recovered clock outputs are complementary clocks operating at half the character rate. Data for the associated receive channels should be latched alternately on the rising edge of RXCLKx+ and RXCLKx-.</p>

Pin Descriptions CYP(V)15G0402DXB Quad HOTLink II™ SERDES (continued)

Name	I/O Characteristics	Signal Description
FRAMCHAR	Three-level Select ^[5] Static Control Input	<p>Framing Character Select. Used to control the type of character used for framing the received data streams.</p> <p>When MID, the framer looks for both positive and negative disparity versions of the eight-bit Comma character.</p> <p>When HIGH, the framer looks for both positive and negative disparity versions of the K28.5 character.</p> <p>Configuring FRAMCHAR to LOW is reserved for component test.</p>
RXCLKA± RXCLKB± RXCLKC± RXCLKD±	LVTTTL Output Clock	<p>Receive Character Clock Output. These true and complement clocks are the Receive interface clocks which are used to control timing of data output transfers. These clocks are output continuously at either the dual-character rate (1/20th the serial bit-rate) or character rate (1/10th the serial bit-rate) of the data being received, as selected by RXRATE.</p>
RFMODE	Three-level Select ^[5] Static Control Input	<p>Reframe Mode Select. Used to control the type of character framing used to adjust the character boundaries (based on detection of one or more framing characters in the received serial bit stream). This signal operates in conjunction with the type of framing character selected.</p> <p>When LOW, the Low-Latency Framer is selected. This will frame on each occurrence of the selected framing character(s) in the received data stream. This mode of framing stretches the recovered character clock for one or multiple cycles to align that clock with the recovered data.</p> <p>When MID, the Cypress-mode Multi-Byte parallel Framer is selected. This requires a pair of the selected framing character(s), on identical 10-bit boundaries, within a span of 50 bits, before the character boundaries are adjusted. The recovered character clock remains in the same phase regardless of character offset.</p> <p>When HIGH, the alternate mode Multi-Byte parallel Framer is selected. This requires detection of the selected framing character(s) of the allowed disparities in the received serial bit stream, on identical 10-bit boundaries, on four directly adjacent characters. The recovered character clock remains in the same phase regardless of character offset.</p>
Device Control Signals		
PARCTL	Three-level Select ^[5] , Static Control Input	<p>Parity Check/Generate Control. Used to control the different parity check and generate functions.</p> <p>When LOW, parity checking is disabled, and the RXOPx outputs are all disabled (High-Z).</p> <p>When MID, the TXDx[9:0] inputs are checked (along with TXOPx) for valid ODD parity, and ODD parity is generated for the RXDx[9:0] outputs and presented on RXOPx.</p> <p>When HIGH, parity checking and generation are enabled. The TXDx[9:0] inputs are checked (along with TXOPx) for valid ODD parity, and ODD parity is generated for the RXDx[9:0] and COMDET_x outputs and presented on RXOPx. See <i>Table 8</i> for details.</p>
REFCLK±	Differential LVPECL or single-ended LVCMOS input clock	<p>Reference Clock. This clock input is used as the timing reference for the transmit PLL. It is also used as the centering frequency of the Range Controller block of the Receive CDR PLLs. This input clock may also be selected to clock the transmit input interface. When driven by a single-ended LVCMOS or LVTTTL clock source, connect the clock source to either the true or complement REFCLK input and leave the alternate REFCLK input open (floating). When driven by an LVPECL clock source, the clock must be a differential clock, using both inputs.</p> <p>When TXCKSEL = LOW, REFCLK is also used as the clock for the parallel transmit data (input) interface.</p>
SPDSEL	Three-level Select ^[5] , Static Control Input	<p>Serial Rate Select. This input specifies the operating bit-rate range of both transmit and receive PLLs. LOW = 195–400 MBaud, MID = 400–800 MBaud, HIGH = 800–1500 MBaud. When SPDSEL is LOW, setting TXRATE = HIGH (Half-rate Reference Clock) is invalid.</p>

Pin Descriptions CYP(V)15G0402DXB Quad HOTLink II™ SERDES (continued)

Name	I/O Characteristics	Signal Description
Analog I/O and Control		
OUTA± OUTB± OUTC± OUTD±	CML Differential Output	Differential Serial Data Outputs. These PECL-compatible CML outputs (+3.3V referenced) are capable of driving terminated transmission lines or standard fiber-optic transmitter modules.
INA± INB± INC± IND±	LVPECL Differential Input	Differential Serial Data Inputs. These inputs accept the serial data stream for deserialization. The INx± serial streams are passed to the receiver Clock and Data Recovery (CDR) circuits to extract the data content when INSELx = HIGH.
OELE	LVTTTL Input, asynchronous, internal pull-up	<p>Serial Driver Output Enable Latch Enable. When OELE = HIGH, the signals on the BOE[7:0] inputs directly control the OUTx± differential drivers.</p> <p>When the BOE[x] input is HIGH, the associated OUTx± differential driver is enabled. When the BOE[x] input is LOW, the associated OUTx± differential driver is powered down.</p> <p>When OELE returns LOW, the last values present on BOE[7:0] are captured in the internal Output enable Latch.</p> <p>The specific mapping of BOE[7:0] signals to transmit output enables is listed in <i>Table 2</i>. If the device is reset ($\overline{\text{TRSTZ}}$ is sampled LOW), the latch is reset to disable all outputs.</p>
BISTLE	LVTTTL Input, asynchronous, internal pull-up	<p>Transmit and Receive BIST Latch Enable. Active HIGH. When BISTLE = HIGH, the signals on the BOE[7:0] inputs directly control the transmit and receive BIST enables.</p> <p>When the BOE[x] input is LOW, the associated transmit or receive channel is configured to generate or compare the BIST sequence.</p> <p>When the BOE[x] input is HIGH, the associated transmit or receive channel is configured for normal data transmission or reception.</p> <p>When BISTLE returns LOW the last values present on BOE[7:0] are captured in the internal BIST Enable Latch.</p> <p>The specific mapping of BOE[7:0] signals to transmit and receive BIST enables is listed in <i>Table 2</i>.</p> <p>When the latch is closed, if the device is reset ($\overline{\text{TRSTZ}}$ is sampled LOW), the latch is reset to disable BIST on all transmit and receive channels.</p>
RXLE	LVTTTL Input, asynchronous, internal pull-up	<p>Receive Channel Power-Control Latch Enable. When RXLE = HIGH, the signals on the BOE[7:0] directly control the power enables for the receive PLLs and analog logic.</p> <p>When the BOE[7:0] input is HIGH, the receive channels PLL's and analog logic are active.</p> <p>When the BOE[7:0] input is LOW, the receive channels are in a power-down mode. When RXLE returns LOW, the last values present on BOE[7:0] are captured in the internal RX PLL Enable Latch.</p> <p>The specific mapping of BOE[7:0] signals to the associated receive channel enables is listed in <i>Table 2</i>.</p> <p>When the device is reset ($\overline{\text{TRSTZ}}$ = LOW), the latch is reset to disable all receive channels.</p>
BOE[7:0]	LVTTTL Input, asynchronous, internal pull-up	<p>BIST, Serial Output, and Receive Channel Enables.</p> <p>These inputs are passed to and through the Output Enable Latch when OELE is HIGH, and captured in this latch when OELE returns LOW.</p> <p>These inputs are passed to and through the BIST Enable Latch when BISTLE is HIGH, and captured in this latch when BISTLE returns LOW.</p> <p>These inputs are passed to and through the Receive Channel Enable Latch when RXLE is HIGH, and captured in this latch when RXLE returns LOW.</p>

Pin Descriptions CYP(V)15G0402DXB Quad HOTLink II™ SERDES (continued)

Name	I/O Characteristics	Signal Description
SDASEL	Three-level Select ^[5] , static configuration input	Signal Detect Amplitude Level Select. Allows selection of one of three predefined amplitude trip points for a valid signal indication, as listed in <i>Table 4</i> .
LPENA LPENB LPENC LPEND	LVTTL Input, asynchronous, internal pull-down	Loop-Back-Enable. Active HIGH. When asserted (HIGH), the transmit serial data from the associated channel is internally routed to its respective receiver clock and data recovery (CDR) circuit. The serial output for the channel where LPENx is active is forced to differential logic "1", and serial data inputs for that channel are ignored.
$\overline{\text{LFIA}}$ $\overline{\text{LFIB}}$ $\overline{\text{LFIC}}$ $\overline{\text{LFID}}$	LVTTL Output, Asynchronous	Link Fault Indication Output. Active LOW. LFIx is the logical OR of four internal conditions: <ol style="list-style-type: none"> 1. Received serial data frequency outside expected range 2. Analog amplitude below expected levels 3. Transition density lower than expected 4. Receive Channel disabled.
$\overline{\text{TRSTZ}}$	LVC MOS Input, internal pull-up	Device Reset. Active LOW. Initializes all state machines and counters in the device. When sampled LOW by the rising edge of REFCLK, this input resets the internal state machines and sets the Elasticity Buffer pointers to a nominal offset. When the reset is removed ($\overline{\text{TRSTZ}}$ sampled HIGH by REFCLK \uparrow), the status and data outputs will become deterministic in fewer than 16 REFCLK cycles. The BISTLE, OELE, and RXLE latches are reset by $\overline{\text{TRSTZ}}$. If the Elasticity Buffer or the Phase Align Buffer are used, $\overline{\text{TRSTZ}}$ should be applied after power up to initialize the internal pointers into these memory arrays.
JTAG Interface		
TMS	LVTTL Input, internal pull-up	Test Mode Select. Used to control access to the JTAG Test Modes. If maintained high for ≥ 5 TCLK cycles, the JTAG test controller is reset. The TAP controller is also reset automatically upon application of power to the device.
TCLK	LVTTL Input, internal pull-down	JTAG Test Clock
TDO	Three-state LVTTL Output	Test Data Out. JTAG data output buffer which is High-Z while JTAG test mode is not selected.
TDI	LVTTL Input, internal pull-up	Test Data In. JTAG data input port.
Power		
V _{CC}		+3.3V Power
GND		Signal and Power Ground for all internal circuits.

CYP(V)15G0402DXB HOTLink II SERDES
Operation

The CYP(V)15G0402DXB is a highly configurable device designed to support reliable transfer of large quantities of data using high-speed serial links from one or multiple sources to multiple destinations. This device supports four character-wide channels.

CYP(V)15G0402DXB Transmit Data Path
Data Path

The transmit path of the CYP(V)15G0402DXB supports four character-wide data paths. These four data paths are internally unencoded and require 10-bit input data that may be pre-encoded or scrambled to achieve sufficient transition density.

Input Register

The bits in the Input Register for each channel have fixed bit assignments, as listed in *Table 1*. Each input register captures a minimum of 10 bits on each input clock cycle. When parity checking is enabled, the TXOPx parity input is also captured in the associated input register.

Input Register Clocking

The transmit Input Registers can be configured to accept data relative to different clock sources. The selection of the clock source is controlled by TXCKSEL.

When TXCKSEL = LOW, the Input Registers for all four transmit channels are clocked by REFCLK \uparrow ^[4]. When TXCKSEL = HIGH, the Input Registers for all four transmit channels are clocked with TXCLKA \uparrow .

When TXCKSEL is MID, TXCLKx \uparrow is used as the input register clock for the associated TXDx[9:0] and TXOPx.

Table 1. Input Register Bit Mapping

Signal Name	Bus Weight	10B Name
TXDx[0] (LSB) ^[6]	2 ⁰	a
TXDx[1]	2 ¹	b
TXDx[2]	2 ²	c
TXDx[3]	2 ³	d
TXDx[4]	2 ⁴	e
TXDx[5]	2 ⁵	i
TXDx[6]	2 ⁶	f
TXDx[7]	2 ⁷	g
TXDx[8]	2 ⁸	h
TXDx[9] (MSB)	2 ⁹	j
TXOPx ^[7]		

Phase-Align Buffer

Data from the Input Registers is normally routed to the associated Phase-Align Buffer. When the transmit paths are operated synchronous to REFCLK \uparrow (TXCKSEL = LOW and TXRATE = LOW), the Phase-Align Buffers are bypassed and data is passed directly to the Parity Check and Serializer blocks to reduce latency.

When an Input-Register clock with an uncontrolled phase relationship to REFCLK is selected (TXCKSEL \neq LOW) or if data is captured on both edges of REFCLK (TXRATE = HIGH), the Phase-Align Buffers are enabled. These buffers are used to absorb clock phase differences between the presently selected input clock and the internal character clock.

Initialization of these Phase-Align Buffers takes place when the TXRST input is sampled LOW by two consecutive rising edges of REFCLK \uparrow . When TXRST is returned HIGH, the present input clock phase relative to REFCLK is set. TXRST is an asynchronous input, but is sampled internally to synchronize it to the internal transmit path state machines.

Once set, the input clocks are allowed to skew in time up to half a character period in either direction relative to REFCLK; i.e., $\pm 180^\circ$. This time shift allows the delay paths of the character clocks (relative to REFCLK) to change due to operating voltage and temperature, while not affecting reliable data transfer.

If the phase offset, between the initialized location of the input clock and REFCLK \uparrow , exceeds the skew handling capabilities of the Phase-Align Buffer, an error is reported on the associated TXPERx output. This output indicates a continuous error until the Phase-Align Buffer is reset. While the error remains active, the transmitter for the associated channel will output a continuous 10-bit character, 1001111000b, to indicate to the remote receiver that an error condition is present in the link.

Parity Support

In addition to the ten data bits that are captured at each channel, a TXOPx input is also available on each channel. This allows the CYP(V)15G0402DXB to support ODD parity

Notes:

6. LSB is shifted out first.
7. The TXOPx inputs are also captured in the associated Input Register, but their interpretation is under the separate control of PARCTL.

checking for each channel. When PARCTL = LOW, parity checking is disabled. When PARCTL = MID or HIGH, parity is checked on the TXDx[9:0] and TXOPx bits.

If parity checking is enabled (PARCTL \neq LOW) and a parity error is detected, the 10-bit character in error is replaced with the 1001111000b pattern (an invalid character).

Transmit BIST

The transmitter interfaces contain internal pattern generators that can be used to validate both device and link operation. These generators are enabled by the associated BOE[x] signals listed in *Table 2* (when the BISTLE latch enable input is HIGH). When enabled, a register in the associated transmit channel becomes a signature pattern generator by logically converting to a Linear Feedback Shift Register (LFSR). This LFSR generates a 511-character sequence that includes all Data and Special Character codes, including the explicit violation symbols. This provides a predictable yet pseudo-random sequence that can be matched to an identical LFSR in the attached Receiver(s).

When the BISTLE signal is HIGH, any BOE[x] input that is LOW enables the BIST generator in the associated transmit channel (or the BIST checker in the associated receive channel). When BISTLE returns LOW, the values of all BOE[x] signals are captured in the BIST Enable Latch. These values remain in the BIST Enable Latch until BISTLE is returned HIGH to open the latch. A device reset ($\overline{\text{TRSTZ}}$ sampled LOW) presets the BIST Enable Latch to disable BIST on all channels.

All data and data-control information present at the associated TXDx[9:0] inputs are ignored when BIST is active on that channel.

Table 2. Output Enable, BIST, and Receive Channel Enable Signal Map

BOE Input	Output Controlled (OELE)	BIST Channel Enable (BISTLE)	Receive PLL Channel Enable (RXLE)
BOE[7]	X	Transmit D	X
BOE[6]	OUTD \pm	Receive D	Receive D
BOE[5]	X	Transmit C	X
BOE[4]	OUTC \pm	Receive C	Receive C
BOE[3]	X	Transmit B	X
BOE[2]	OUTB \pm	Receive B	Receive B
BOE[1]	X	Transmit A	X
BOE[0]	OUTA \pm	Receive A	Receive A

Serial Output Drivers

The serial interface Output Drivers use differential CML (Current Mode Logic) to provide a source-matched driver for the transmission lines. These drivers accept data from the Transmit Shifters. These outputs have signal swings equivalent to that of standard PECL drivers and are capable of driving AC-coupled optical modules or transmission lines.

When configured for local loopback (LPENx = HIGH), the output drivers for all enabled ports are configured to drive a static differential logic-1.

Each output can be enabled or disabled separately through the BOE[7:0] inputs, as controlled by the OELE latch-enable signal. When OELE is HIGH, the signals present on the BOE[7:0] inputs are passed through the Serial Output Enable Latch to control the Serial Output Drivers. The BOE[7:0] input associated with a specific OUTx± driver is listed in *Table 2*.

When OELE is HIGH and BOE[x] is HIGH, the associated Serial Driver is enabled. When OELE is HIGH and BOE[x] is LOW, the associated driver is disabled and internally powered down, the associated internal logic for that channel is also powered down. When OELE returns LOW, the values present on the BOE[7:0] inputs are latched in the Output Enable Latch, and remain there until OELE returns HIGH to enable the latch. A device reset (TRSTZ sampled LOW) clears this latch and disables all output drivers.

NOTE: When all transmit channels are disabled (i.e., both serial output drivers disabled in all channels) and a serial output driver is re-enabled, the data on the Serial Drivers may not meet all timing specifications for up to 200 μs.

Transmit PLL Clock Multiplier

The Transmit PLL Clock Multiplier accepts a character-rate or half-character-rate external clock at the REFCLK input, and multiplies that clock by 10 or 20 (as selected by TXRATE) to generate a bit-rate clock for use by the Transmit Shifter. It also provides a character-rate clock used by the transmit paths.

The clock multiplier PLL can accept a REFCLK input between 19.5 MHz and 150 MHz, however, this clock range is limited by the operating mode of the CYP(V)15G0402DXB clock multiplier (controlled by TXRATE) and by the level on the SPDSEL input.

When TXCKSEL = MID or HIGH (TXCLKx or TXCLKA selected to clock input register), TXRATE = HIGH (Half-rate REFCLK) is an invalid mode of operation.

SPDSEL is a three-level select^[5] (ternary) input that selects one of three operating ranges for the serial data outputs and inputs. The operating serial signaling-rate and allowable range of REFCLK frequencies is listed in *Table 3*.

Table 3. Operating Speed Settings

SPDSEL	TXRATE	REFCLK Frequency (MHz)	Signaling Rate (Mbaud)
LOW	1	reserved	195-400
	0	19.5-40	
MID (Open)	1	20-40	400-800
	0	40-80	
HIGH	1	40-75	800-1500
	0	80-150	

Note:

8. REFCLK has no phase or frequency relationship with the recovered clock(s) and only acts as a centering reference to reduce clock synchronization time. REFCLK must be within ±1500 PPM (±0.15%) of the remote transmitter's PLL reference (REFCLK) frequency. Although transmitting to a HOTLink II receiver necessitates the frequency difference between the transmitter and receiver reference clocks to be within ±1500 ppm, the stability of the crystal needs to be within the limits specified by the appropriate standard when transmitting to a remote receiver that is compliant to that standard. For example, to be IEEE 802.3z Gigabit Ethernet compliant, the frequency stability of the crystal needs to be within ±100 ppm.

The REFCLK± input is a differential input with each input internally biased to 1.4V. If the REFCLK+ input is connected to a TTL, LVTTTL, or LVCMOS clock source, the input signal is recognized when it passes through the internally biased reference point and REFCLK- can be left floating.

When both the REFCLK+ and REFCLK- inputs are connected, the clock source must be a differential clock. This can be either a differential LVPECL clock that is DC- or AC-coupled, or a differential LVTTTL or LVCMOS clock.

By connecting the REFCLK- input to an external voltage source or resistive voltage divider, it is possible to adjust the reference point of the REFCLK+ input for alternate logic levels. When doing so it is necessary to ensure that the input differential crossing point remains within the parametric range supported by the input.

CYP(V)15G0402DXB Receive Data Path

Serial Line Receivers

A differential line receiver, INx±, is available on each channel for accepting a serial bit stream. The Serial Line Receiver inputs are differential, and can accommodate wire interconnect and filtering losses or transmission line attenuation greater than 16 dB. For normal operation, these inputs should receive a signal of at least $V_{DIFF} > 100$ mV, or 200 mV peak-to-peak differential. Each Line Receiver can be DC- or AC-coupled to +3.3V powered fiber-optic interface modules (any ECL/PECL family, not limited to 100K PECL) or AC-coupled to +5V powered optical modules. The common-mode tolerance of these line receivers accommodates a wide range of signal termination voltages. Each receiver provides internal DC-restoration, to the center of the receiver's common mode range, for AC-coupled signals.

The local loopback inputs (LPENx) for each channel allows the serial transmit data outputs to be routed internally back to the Clock and Data Recovery circuit associated with that channel. When configured for local loopback, all transmit Serial Driver outputs are forced to output a differential logic-1. This prevents local diagnostic patterns from being broadcast to attached remote receivers.

Signal Detect/ Link Fault

Each selected Line Receiver is simultaneously monitored for

- analog amplitude above limit specified by SDASEL
- transition density greater than specified limit
- CDR tracking data within expected frequency range as defined by REFCLK and TXRATE (± 1500 ppm)^[8]
- receive channel enabled

All of these conditions must be valid for the Signal Detect block to indicate a valid signal is present. This status is presented on the LFlx (Link Fault Indicator) output associated with each receive channel.

Analog Amplitude

While most signal monitors are based on fixed constants, the analog amplitude level detection is adjustable. This allows operation with highly attenuated signals, or in high-noise environments. This adjustment is made through the SDASEL signal, a three-level select^[5] input, which sets the trip point for the detection of a valid signal at one of three levels, as listed in *Table 4*. This control input affects the analog monitors for all receive channels.

When a particular channel is configured for local loopback (LPENx = HIGH), no line receivers are selected, and the LFIx output for each channel reports only the receive VCO frequency out-of-range and transition density status of the associated transmit signal. When local loopback is active, the Analog Signal Detect Monitors are disabled.

Table 4. Analog Amplitude Detect Valid Signal Levels^[9]

SDASEL	Typical Signal with Peak Amplitudes Above
LOW	140 mV p-p differential
MID (Open)	280 mV p-p differential
HIGH	420 mV p-p differential

Transition Density

The Transition Detection logic checks for the absence of any transitions spanning greater than six transmission characters (60 bits). If no transitions are present in the data received on a channel, the Transition Detection logic for that channel will assert LFIx. The LFIx output remains asserted until at least one transition is detected in each of three adjacent received characters.

Range Controls

The Clock/Data Recovery (CDR) circuit includes logic to monitor the frequency of the Phase Locked Loop (PLL) Voltage Controlled Oscillator (VCO) used to sample the incoming data stream. This logic ensures that the VCO operates at, or near the rate of the incoming data stream for two primary cases:

- when the incoming data stream resumes after a time in which it has been “missing”
- when the incoming data stream is outside the acceptable frequency range

To perform this function, the frequency of the VCO is periodically sampled and compared to the frequency of the REFCLK input. If the VCO is running at a frequency beyond $\pm 1500\text{ppm}$ ^[8] as defined by the reference clock frequency, it is periodically forced to the correct frequency (as defined by REFCLK, SPDSEL, and TXRATE) and then released in an attempt to lock to the input data stream. The sampling and relock period of the Range Control is calculated as follows: RANGE CONTROL SAMPLING PERIOD = (REFCLK-PERIOD) * (16000).

During the time that the Range Control forces the PLL VCO to run at REFCLK*10 (or REFCLK*20 when TXRATE = HIGH)

Notes:

9. The peak amplitudes listed in this table are for typical waveforms that have generally 3 – 4 transitions for every ten bits. In a worse case environment the signals may have a sign-wave appearance (highest transition density with repeating 0101...). Signal peak amplitudes levels within this environment type could increase the values in the table above by approximately 100 mV.
10. When a disabled receive channel is reenabled, the status of the associated LFIx output and data on the parallel outputs for the associated channel may be indeterminate for up to 2 ms.

rate, the LFIx output will be asserted LOW. While the PLL is attempting to re-lock to the incoming data stream, LFIx may be either HIGH or LOW (depending on other factors such as transition density and amplitude detection) and the recovered byte clock (RXCLKx) may run at an incorrect rate (depending on the quality or existence of the input serial data stream). After a valid serial data stream is applied, it may take up to one RANGE CONTROL SAMPLING PERIOD before the PLL locks to the input data stream, after which LFIx should be HIGH.

Receive Channel Enabled

The CYP(V)15G0402DXB contains four receive channels that can be independently enabled and disabled. Each channel can be enabled or disabled separately through the BOE[7:0] inputs, as controlled by the RXLE latch-enable signal. When RXLE is HIGH, the signals present on the BOE[7:0] inputs are passed through the Receive Channel Enable Latch to control the PLLs and logic of the associated receive channel. The BOE[7:0] input associated with a specific receive channel is listed in *Table 2*.

When RXLE is HIGH and BOE[x] is HIGH, the associated receive channel is enabled to receive and recover a serial stream. When RXLE is HIGH and BOE[x] is LOW, the associated receive channel is disabled and powered down. Any disabled channel will indicate an asserted LFIx output. When RXLE returns LOW, the values present on the BOE[7:0] inputs are latched in the Receive Channel Enable Latch, and remain there until RXLE returns HIGH to open the latch again.^[10]

Clock/Data Recovery

The extraction of a bit-rate clock and recovery of bits from each received serial stream is performed by a separate Clock/Data Recovery (CDR) block within each receive channel. The clock extraction function is performed by embedded phase-locked loops (PLLs) that track the frequency of the transitions in the incoming bit streams and align the phase of their internal bit-rate clocks to the transitions in the selected serial data streams.

Each CDR accepts a character-rate (bit-rate \div 10) or half-character-rate (bit-rate \div 20) reference clock from the REFCLK input. This REFCLK input is used to

- ensure that the VCO (within the CDR) is operating at the correct frequency.
- to reduce PLL acquisition time
- and to limit unlocked frequency excursions of the VCO when there is no input data present at the selected Serial Line Receiver.

Regardless of the type of signal present, the CDR will attempt to recover a data stream from it. If the frequency of the recovered data stream is outside the limits of the range control monitor, the CDR will switch to track REFCLK instead of the data stream. Once the CDR output (RXCLKx) frequency returns back close to REFCLK frequency, the CDR input will be switched back to track the input data stream.

In case no data is present at the input, this switching behavior may result in brief RXCLKx frequency excursions from REFCLK. However, the validity of the input data stream is indicated by the LFlx output. The frequency of REFCLK is required to be within $\pm 1500\text{ppm}$ ^[8] of the frequency of the clock that drives the REFCLK input of the remote transmitter to ensure a lock to the incoming data stream.

Deserialzer/Framer

Each CDR circuit extracts bits from the associated serial data stream and clocks these bits into the Shifter/Framer at the bit-clock rate. When enabled, the Framer examines the data stream, looking for one or more Comma or K28.5 characters at all possible bit positions. The location of this character in the data stream is used to determine the character boundaries of all following characters.

Framing Character

The CYP(V)15G0402DXB allows selection of one of two combinations of framing characters to support requirements of different interfaces. The selection of the framing character is made through the FRAMCHAR input.

Table 5. Framing Character Selector

FRAMCHAR	Bits Detected in Framer	
	Character Name	Bits Detected
LOW	Reserved for test	
MID (Open)	Comma+ or Comma-	00111110XX ^[11] or 11000001XX
HIGH	+K28.5 or -K28.5	0011111010 or 1100000101

The specific bit combinations of these framing characters are listed in *Table 5*. When the specific bit combination of the selected framing character is detected by the Framer, the boundaries of the characters present in the received data stream are known.

Framer

The Framer on each channel operates in one of three different modes, as selected by the RFMODE input. In addition, the Framer for each channel may be enabled or disabled through the RFENx input. When RFENx = LOW, the framer in that receive path is disabled, and no combination of bits in a received data stream will alter the character boundaries. When RFENx = HIGH, the Framer selected by RFMODE is enabled for that channel.

When RFMODE = LOW, the Low-Latency Framer is selected. This Framer operates by stretching the recovered character clock until it aligns with the received character boundaries. In this mode, the Framer starts its alignment process on the first detection of the selected framing character. To reduce the impact on external circuits that make use of a recovered clock, the clock period is not stretched by more than two bit-periods in any one clock cycle. When operated with a character-rate

Notes:

11. The standard definition of a Comma contains only seven bits. However, since all valid Comma characters within the 8B/10B character set also have the eighth bit as an inversion of the seventh bit, the compare pattern is extended to a full eight bits to reduce the possibility of a framing error.
12. When Receive BIST is enabled on a channel, the Low-Latency Framer must not be enabled. The BIST sequence contains an aliased K28.5 framing character, which causes the Receiver to update its character boundaries incorrectly.

output clock (RXRATE = LOW), the output of properly framed characters may be delayed by up to nine character-clock cycles from the detection of the selected framing character. When operated with a half-character-rate output clock (RXRATE = HIGH), the output of properly framed characters may be delayed by up to 14 character-clock cycles from the detection of the selected framing character.^[8]

When RFMODE is MID (open), the Cypress-mode Multi-Byte Framer is selected. The required detection of multiple framing characters makes the associated link much more robust to incorrect framing due to aliased framing characters in the data stream. In this mode, the Framer does not adjust the character clock boundary, but instead aligns the character to the already recovered character clock. This ensures that the recovered clock will not contain any significant phase changes or hops during normal operation or framing, and allows the recovered clock to be replicated and distributed to other external circuits or components using PLL-based clock distribution elements. In this framing mode, the character boundaries are only adjusted if the selected framing character is detected at least twice within a span of 50 bits, with both instances on identical 10-bit character boundaries.

When RFMODE = HIGH, the Alternate-mode Multi-Byte Framer is enabled. Like the Cypress-mode Multi-Byte Framer, multiple framing characters must be detected before the character boundary is adjusted. In this mode, the Framer does not adjust the character clock boundary, but instead aligns the character to the already recovered character clock. In this mode, the data stream must contain a minimum of four of the selected framing characters, received as consecutive characters, on identical 10-bit boundaries, before character framing is adjusted.

Framing is enabled for a channel when the associated RFENx input is HIGH. When RFENx is LOW, the framer for the associated channel is disabled. When a framer is disabled, no changes are made to the recovered character boundaries on that channel, regardless of the presence of framing characters in the data stream.

Receive BIST Operation

The Receiver interfaces contain internal pattern generators that can be used to validate both device and link operation. These generators are enabled by the associated BOE[x] signals listed in *Table 2* (when the BISTLE latch enable input is HIGH). When enabled, a register in the associated receive channel becomes a pattern generator and checker by logically converting to a Linear Feedback Shift Register (LFSR). This LFSR generates a 511-character sequence that includes all Data and Special Character codes, including the explicit violation symbols. This provides a predictable yet pseudo-random sequence that can be matched to an identical LFSR in the attached Transmitter(s). When synchronized with the received data stream, the associated Receiver compares each received character with each character generated by the LFSR and indicates compare errors and BIST status at the COMDET_x and RXD_x[1:0] bits of the Output Register^[12].

When the BISTLE signal is HIGH, any BOE[x] input that is LOW enables the BIST generator/checker in the associated Receive channel (or the BIST generator in the associated Transmit channel). When BISTLE returns LOW, the values of all BOE[x] signals are captured in the BIST Enable Latch. These values remain in the BIST Enable Latch until BISTLE is returned HIGH. All captured signals in the BIST Enable Latch are set HIGH (i.e., BIST is disabled) following a device reset (TRSTZ is switched LOW).

When BIST is first recognized as being enabled in the Receiver, the LFSR is preset to the BIST-loop start-code of D0.0. This code D0.0 is sent only once per BIST loop. The status of the BIST progress and any character mismatches is presented on the COMDET_x and RXD_x[1:0] status outputs.

COMDET_x, RXD_x[1:0] indicates 010b or 100b for one character period per BIST loop to indicate loop completion. This status can be used to check test pattern progress. The status reported by the BIST state machine on COMDET_x and RXD_x[1:0] are listed in *Table 6*.

The specific patterns checked by each receiver are described in detail in the Cypress application note "HOTLink Built-In Self-Test." The sequence compared by the CYP(V)15G0402DXB is identical to that in the CY7B933 and CY7C924DX, allowing interoperable systems to be built when used at compatible serial signaling rates. If the number of invalid characters received ever exceeds the number of valid characters by 16, the receive BIST state machine aborts the compare operations and resets the LFSR to the D0.0 state to look for the start of the BIST sequence again.

The BIST state machine requires the characters to be correctly framed for it to detect the BIST sequence. If the Low Latency Framer is enabled (RFMODE = LOW), the Framer will misalign to an aliased K28.5 framing character within the BIST sequence. If the Alternate Multi-Byte Framer is enabled (RFMODE = HIGH), it is necessary to frame the receiver before BIST is enabled.

Power Control

The CYP(V)15G0402DXB supports user control of the powered up or down state of each transmit and receive channel. The receive channels are controlled by the RXLE signal and the values present on the BOE[7:0] bus. The transmit channels are controlled by the OELE signal and the values present on the BOE[7:0] bus. Powering down unused channels will save power and reduce system heat generation. Controlling system power dissipation will improve the system performance.

Receive Channels

When RXLE is HIGH, the signals on the BOE[7:0] inputs directly control the power enables for the receive PLLs and analog circuits. When a BOE[7:0] input is HIGH, the associated receive channel [A through D] PLL and analog logic are active. When a BOE[7:0] input is LOW, the associated receive channel [A through D] PLL and analog circuits are powered down. When RXLE returns LOW, the last values present on the BOE[7:0] inputs are captured. The specific BOE[7:0] input signal associated with a receive channel is listed in *Table 2*.

Any disabled receive channel will indicate a constant LFix output.

Table 6. BIST Status Bits

Status			Priority	Description
COMDET _x	RXD _x [0]	RXD _x [1]		
BIST Mode				
0	0	0	7	BIST Data Compare. Data Character compared correctly.
0	0	1	7	BIST Command Compare. Command Character compared correctly.
0	1	0	2	BIST Last Good. Last Character of BIST sequence detected and valid.
0	1	1	5	Reserved
1	0	0	4	BIST Last Bad. Last Character of BIST sequence was detected invalid.
1	0	1	1	BIST Start. RXBISTEN recognized on this channel, but character compares have not yet commenced. Also presented when the receive PLL is tracking REFCLK instead of the selected data stream.
1	1	0	6	BIST Error. While comparing characters, a mismatch was found in one or more of the decoded character bits.
1	1	1	3	BIST Wait. The receiver is comparing characters. but has not yet found the start of BIST character to enable the LFSR.

When a disabled receive channel is re-enabled, the status of the associated LFix output and data on the parallel outputs for the associated channel may be indeterminate for up to 2 ms.

Transmit Channels

When OELE is HIGH, the signals on the BOE[7:0] inputs directly control the power enables for the Serial Drivers. When a BOE[x] input is HIGH, the associated Serial Driver is enabled. When a BOE[x] input is LOW, the associated Serial Driver is disabled and powered down. If the Serial Driver of a channel is disabled, the internal logic for that channel is powered down. When OELE returns LOW, the values present on the BOE[7:0] inputs are latched in the Output Enable Latch.

Device Reset State

When the CYP(V)15G0402DXB is reset by assertion of TRSTZ, the Transmit Enable and Receive Enable Latches are both cleared, and the BIST Enable Latch is preset. In this state, all transmit and receive channels are disabled, and BIST is disabled on all channels.

Following a device reset, it is necessary to enable the transmit and receive channels used for normal operation. This can be done by sequencing the appropriate values on the BOE[7:0] inputs while the OELE and RXLE signals are raised and lowered. For systems that do not require dynamic control of power, or want the part to power up in a fixed configuration, it is also possible to strap the RXLE and OELE control signals HIGH to permanently enable their associated latches. Connection of the associated BOE[7:0] signals to a stable HIGH will then enable the respective transmit and receive channels as soon as the TRSTZ signal is deasserted.

Output Bus

Each receive channel presents a 12-signal output bus consisting of:

- a 10-bit data bus
- a COMMA detect indicator
- a parity bit.

The signals present on this output bus are shown in *Table 7*.

Table 7. Output Register Bit Assignment

Signal Name	Bus Weight	10B Name
RXOPx ^[13]		
COMDETx ^[13]		
RXDx[0] (LSB)	2 ⁰	a
RXDx[1]	2 ¹	b
RXDx[2]	2 ²	c
RXDx[3]	2 ³	d
RXDx[4]	2 ⁴	e
RXDx[5]	2 ⁵	i
RXDx[6]	2 ⁶	f
RXDx[7]	2 ⁷	g
RXDx[8]	2 ⁸	h
RXDx[9] (MSB)	2 ⁹	j

The framed 10-bit value is presented to the associated Output Register, along with a status output (COMDETx) indicating if the character in the output register matches the selected framing characters.

The COMDETx output is HIGH when the character in the Output Register of the associated channel contains the selected framing character at the proper character boundary, and LOW for all other bit combinations.

When the Low-Latency Framer and half-rate receive port clocking are also enabled (RFMODE = LOW, RXRATE = HIGH), the Framer will stretch the recovered clock to the nearest 20-bit boundary such that the rising edge of RXCLKx+ occurs when COMDETx is present on the associated output bus.

When the Cypress or Alternate Mode Framer is enabled and half-rate receive port clocking are also enabled (RFMODE ≠ LOW and RXRATE = HIGH), the output clock is not modified when framing is detected, but a single pipeline stage may be added or subtracted from the data stream by the Framer logic such that the rising edge of RXCLKx+ occurs when COMDETx is present on the associated output bus.

This adjustment only occurs when the Framer is enabled (RFEN = HIGH). When the Framer is disabled, the clock boundaries are not adjusted, and COMDETx may be asserted during the rising edge of RXCLK- (if an odd number of characters were received following the initial framing).

Notes:

13. The RXOPx and COMDETx outputs are also driven from the associated output register, but their generation and interpretation are separate from the data bus.
14. Receive path parity output drivers are disabled when PARCTL is low
15. When BIST is not enabled, COMDETx is usually driven to a logic 0, but will be driven high when the character in the output buffer is the selected framing character.

Parity Generation

In addition to the 10-bit data and COMDETx status bit, an RXOPx ODD parity output can also be generated for each channel. Parity can be generated on

- the RXDx[9:0] character
- RXDx[9:0] character and COMDETx status bit.

These modes differ in the number of bits which are included in the parity calculation. Only ODD parity is provided which ensures that at least one bit of the data bus is always a logic-1. Those bits covered by parity generation are listed in *Table 8*.

Parity generation is enabled through the three-level select PARCTL input. When PARCTL = LOW, parity checking is disabled, and the RXOPx outputs are all disabled (High-Z).

When PARCTL is MID, ODD parity is generated for the RXDx[9:0] bits.

When PARCTL is HIGH, ODD parity is generated for both the RXDx[9:0] bits and the associated COMDETx signal.

Table 8. Output Register Parity Generation

Signal Name	Receive Parity Generate Mode (PARCTL)		
	LOW ^[14]	MID	HIGH
COMDETx			X ^[15]
RXDx[0]		X	X
RXDx[1]		X	X
RXDx[2]		X	X
RXDx[3]		X	X
RXDx[4]		X	X
RXDx[5]		X	X
RXDx[6]		X	X
RXDx[7]		X	X
RXDx[8]		X	X
RXDx[9]		X	X

BIST Status State Machine

When a receive path is enabled to look for and compare the received data stream with the BIST pattern, the COMDETx and RXDx[1:0] bits identify the present state of the BIST compare operation.

The BIST state machine has multiple states, as shown in *Figure 2* and *Table 6*. When the receive PLL detects an out-of-lock condition, the BIST state is forced to the Start-of-BIST state, regardless of the present state of the BIST state machine. If the number of detected errors ever exceeds the number of valid matches by greater than 16, the state machine is forced to the WAIT_FOR_BIST state where it monitors the interface for the first character (D0.0) of the next BIST sequence. Also, if the Elasticity Buffer ever hits an overflow/underflow condition, the status is forced to the BIST_START until the buffer is re-centered (approximately nine character periods).

JTAG Support

The CYP(V)15G0402DXB contains a JTAG port to allow system level diagnosis of device interconnect. Of the available JTAG modes, only boundary scan is supported. This capability is present only on the LVTTL inputs, LVTTL outputs and REFCLK± input. The high-speed serial signals are not part of the JTAG test chain.

JTAG ID

The JTAG device ID for the CYP(V)15G0402DXB is '1C801069'hex.

Three-level Select Inputs

Each three-level select input reports as two bits in the scan register. These bits report the LOW, MID, and HIGH state of the associated input as 00, 10, and 11, respectively.

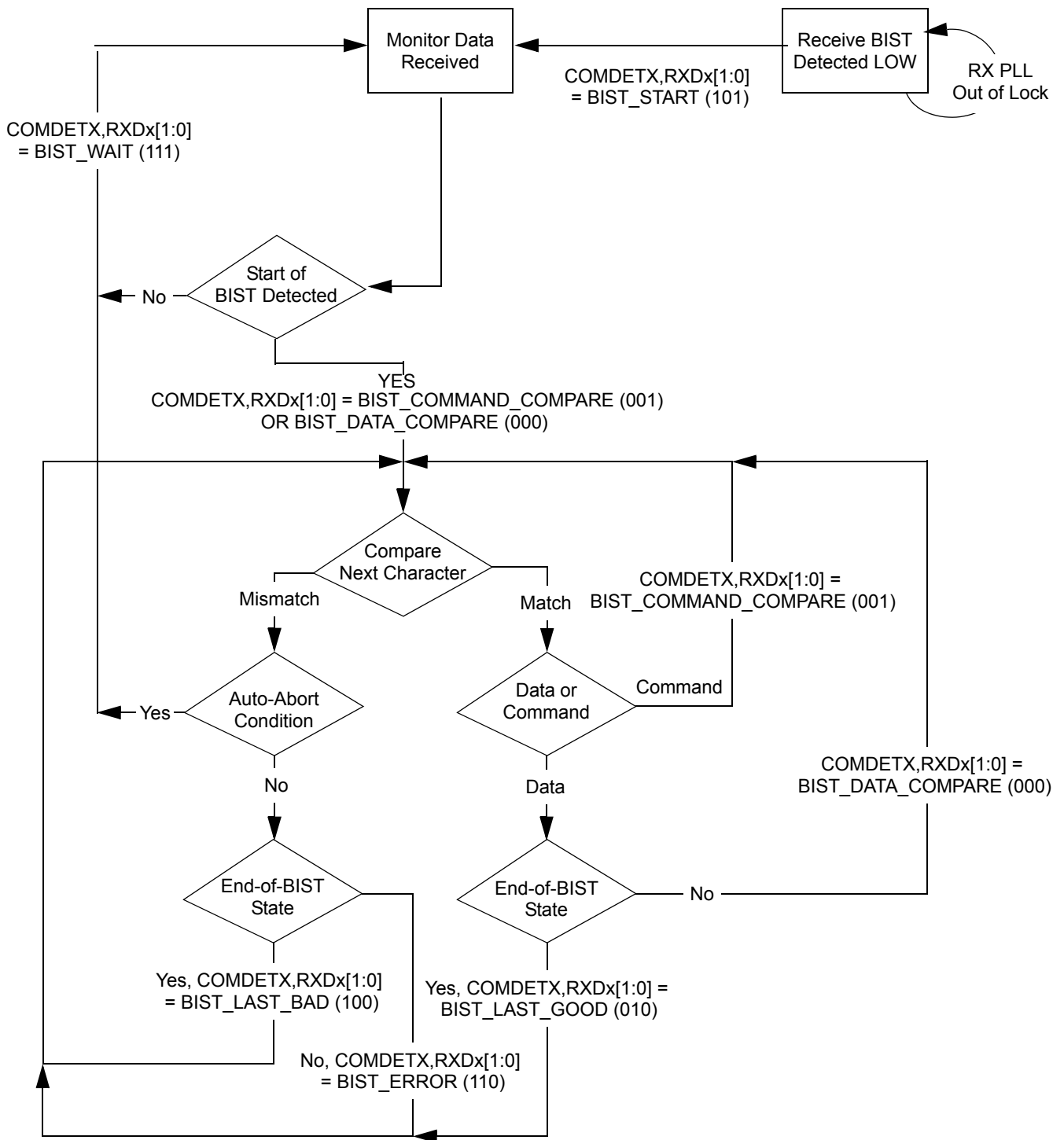

Figure 2. Receive BIST State Machine



Maximum Ratings

(Above which the useful life may be impaired. User guidelines only, not tested.)

- Storage Temperature-65°C to +150°C
- Ambient Temperature with Power Applied.....-55°C to +125°C
- DC Voltage Applied to LVTTTL Outputs in High-Z State-0.5V to $V_{CC} + 0.5V$
- Supply Voltage to Ground Potential -0.5V to +3.8V
- Output Current into LVTTTL Outputs (LOW).....60 mA
- DC Input Voltage-0.5V to $V_{CC} + 0.5V$

Static Discharge Voltage..... > 2000 V (per MIL-STD-883, Method 3015)

Latch-up Current..... > 200 mA

Power-up Requirements

The CYP(V)15G0402DXB requires one power supply. The voltage on any input or I/O pin cannot exceed the power pin during power-up.

Operating Range

Range	Ambient Temperature	V_{CC}
Commercial	0°C to +70°C	3.3V ± 5%
Industrial	-40°C to +85°C	3.3V ± 5%

CYP(V)15G0402DXB DC Electrical Characteristics Over the Operating Range

Parameter	Description	Test Conditions	Min.	Max.	Unit
LVTTTL-compatible Outputs					
V_{OHT}	Output HIGH Voltage	$I_{OH} = -4 \text{ mA}, V_{CC} = \text{Min.}$	2.4	V_{CC}	V
V_{OLT}	Output LOW Voltage	$I_{OL} = 4 \text{ mA}, V_{CC} = \text{Min.}$	0	0.4	V
I_{OST}	Output Short Circuit Current	$V_{OUT} = 0V^{[16]}$	-20	-100	mA
I_{OZL}	High-Z Output Leakage Current		-20	20	mA
LVTTTL-compatible Inputs					
V_{IHT}	Input HIGH Voltage		2.0	$V_{CC} + 0.3$	V
V_{ILT}	Input LOW Voltage		-0.5	0.8	V
I_{IHT}	Input HIGH Current	REFCLK Input, $V_{IN} = V_{CC}$		+1.5	mA
		Other Inputs, $V_{IN} = V_{CC}$		+40	µA
I_{ILT}	Input LOW Current	REFCLK Input, $V_{IN} = 0.0V$		-1.5	mA
		Other Inputs, $V_{IN} = 0.0V$		-40	µA
I_{IHPDT}	Input HIGH Current with internal pull-down	$V_{IN} = V_{CC}$		+200	µA
I_{ILPUT}	Input LOW Current with internal pull-up	$V_{IN} = 0.0V$		-200	µA
LVDIFF Inputs: REFCLK±					
$V_{DIFF}^{[17]}$	Input Differential Voltage		400	V_{CC}	mV
V_{IHHP}	Highest Input HIGH Voltage		1.2	V_{CC}	V
V_{ILLP}	Lowest Input LOW voltage		0.0	$V_{CC}/2$	V
$V_{COMREF}^{[18]}$	Common Mode Range		1.0	$V_{CC} - 1.2V$	V
Three-level Inputs					
V_{IHH}	Three-level Input HIGH Voltage	Min. ≤ V_{CC} ≤ Max.	$0.87 * V_{CC}$	V_{CC}	V
V_{IMM}	Three-level Input MID Voltage	Min. ≤ V_{CC} ≤ Max.	$0.47 * V_{CC}$	$0.53 * V_{CC}$	V
V_{ILL}	Three-level Input LOW Voltage	Min. ≤ V_{CC} ≤ Max.	0.0	$0.13 * V_{CC}$	V
I_{IHH}	Input High Current	$V_{in} = V_{CC}$		200	µA
I_{IMM}	Input MID Current	$V_{in} = V_{CC}/2$	-50	50	µA
I_{ILL}	Input LOW Current	$V_{in} = GND$		-200	µA
Differential CML Serial Outputs: OUTA±, OUTB±, OUTC±, OUTD±			Typ.	Max.	Unit
V_{OHC}	Output HIGH Voltage	100Ω differential load	$V_{CC} - 0.5$	$V_{CC} - 0.2$	V
		150Ω differential load	$V_{CC} - 0.5$	$V_{CC} - 0.2$	V

Notes:

- 16. Tested one output at a time, output shorted for less than one second, less than 10% duty cycle.
- 17. This is the minimum difference in voltage between the true and complement inputs required to ensure detection of a logic-1 or logic-0. A logic-1 exists when the true (+) input is more positive than the complement (-) input. A logic-0 exists when the complement (-) input is more positive than true (+) input.
- 18. The common mode range defines the allowable range of REFCLK+ and REFCLK- when REFCLK+ = REFCLK-. This marks the zero-crossing between the true and complement inputs as the signal switches between a logic-1 and a logic-0.

CYP(V)15G0402DXB DC Electrical Characteristics Over the Operating Range (continued)

Parameter	Description	Test Conditions	Min.	Max.	Unit
V _{OLC}	Output LOW Voltage	100Ω differential load	V _{CC} - 1.1	V _{CC} - 0.7	V
		150Ω differential load	V _{CC} - 1.1	V _{CC} - 0.7	V
V _{ODIF}	Output Differential Voltage (OUT+) - (OUT-)	100Ω differential load	450	900	mV
		150Ω differential load	560	1000	mV
Differential Serial Line Receiver Inputs: INA±, INB±, INC±, IND±					
V _{DIFFS} ^[17]	Input Differential Voltage (IN+) - (IN-)		100	1200	mV
V _{IHE}	Highest Input HIGH Voltage			V _{CC}	V
V _{ILE}	Lowest Input LOW Voltage		V _{CC} - 2.0		V
I _{IHE}	Input HIGH Current	V _{IN} = V _{IHH} Max.		1350	mA
I _{ILE}	Input LOW Current	V _{IN} = V _{ILL} Min.	-700		mA
V _{COM} ^[19, 20]	Common mode input range		V _{CC} - 1.95	V _{CC} - 0.05	V

Power Supply			Typ. ^[22]	Max. ^[21]	Unit
I _{CC}	Power Supply Current REFCLK = Max.	Commercial	870	1060	mA
		Industrial		1100	mA
I _{CC}	Power Supply Current REFCLK = 125 MHz	Commercial	830	1060	mA
		Industrial		1100	mA

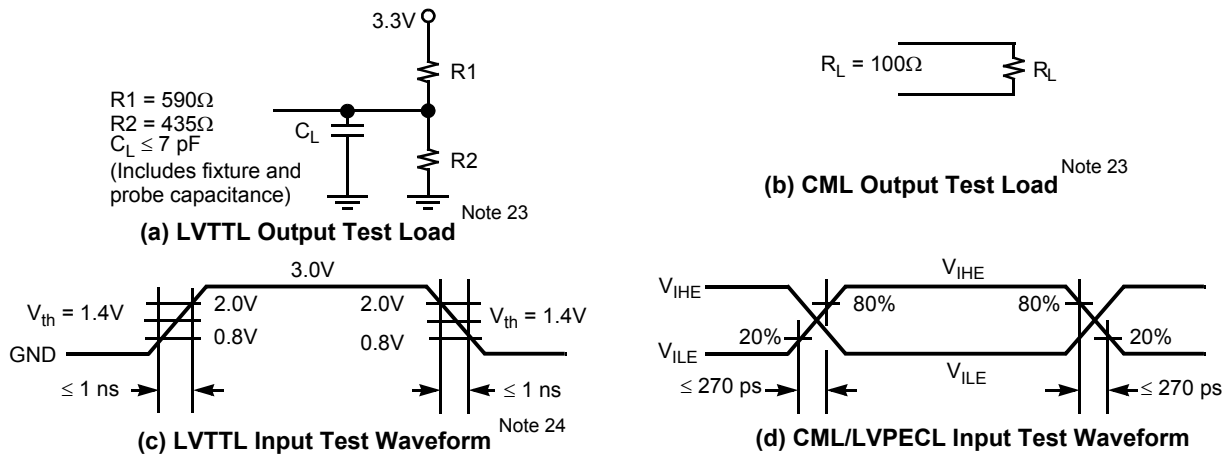
Test Loads and Waveforms

Notes:

- The common mode range defines the allowable range of INPUT+ and INPUT- when INPUT+ = INPUT-. This marks the zero-crossing between the true and complement inputs as the signal switches between a logic-1 and a logic-0.
- Not applicable for AC-coupled interfaces. For AC-coupled interfaces, V_{DIFFS} requirement still needs to be satisfied.
- Maximum I_{CC} is measured with V_{CC} = MAX, parallel outputs unloaded, RX channels enabled, and Serial Line Drivers enabled and sending a continuous alternating 01 pattern to the associated receive channel.
- Typical I_{CC} is measured under similar conditions except with V_{CC} = 3.3V, T_A = 25°C, parallel outputs unloaded, RX channels enabled, and Serial Line Drivers enabled and sending a continuous alternating 01 pattern to the associated receive channel.
- Cypress uses constant current (ATE) load configurations and forcing functions. This figure is for reference only. 5-pF differential load reflects tester capacitance, and is recommended at low data rates only.
- The LVTTTL switching threshold is 1.4V. All timing references are made relative to the point where the signal edges crosses the threshold voltage.

CYP(V)15G0402DXB AC Characteristics Over the Operating Range

CYP(V)15G0402DXB Transmitter LVTTTL Switching Characteristics Over the Operating Range

Parameter	Description	Min.	Max.	Unit
f_{TS}	TXCLKx Clock Frequency	19.5	150	MHz
t_{TXCLK}	TXCLKx Period	6.66	51.28	ns
$t_{TXCLKH}^{[25]}$	TXCLKx HIGH Time	2.2		ns
$t_{TXCLKL}^{[25]}$	TXCLKx LOW Time	2.2		ns
$t_{TXCLKR}^{[25, 26, 27]}$	TXCLKx Rise Time	0.2	1.7	ns
$t_{TXCLKF}^{[25, 26, 27]}$	TXCLKx Fall Time	0.2	1.7	ns
t_{TXDS}	Transmit Data Set-up Time to TXCLKx \uparrow (TXCKSEL \neq LOW)	1.7		ns
t_{TXDH}	Transmit Data Hold Time from TXCLKx \uparrow (TXCKSEL \neq LOW)	0.8		ns
f_{TOS}	TXCLKO Clock Frequency = 1x or 2x REFCLK Frequency	19.5	150	MHz
t_{TXCLKO}	TXCLKO Period	6.66	51.28	ns
$t_{TXCLKOD+}$	TXCLKO+ Duty Cycle with 60% HIGH time	-1.0	+0.5	ns
$t_{TXCLKOD-}$	TXCLKO- Duty Cycle with 40% HIGH time	-0.5	+1.0	ns

CYP(V)15G0402DXB Receiver LVTTTL Switching Characteristics Over the Operating Range

Parameter	Description	Min.	Max.	Unit
f_{RS}	RXCLKx Clock Output Frequency	9.75	150	MHz
t_{RXCLKP}	RXCLKx Period	6.66	102.56	ns
t_{RXCLKH}	RXCLKx HIGH Time (RXRATE = LOW)	2.33 ^[25]	26.64	ns
	RXCLKx HIGH Time (RXRATE = HIGH)	5.66	52.28	ns
t_{RXCLKL}	RXCLKx LOW Time (RXRATE = LOW)	2.33 ^[25]	26.64	ns
	RXCLKx LOW Time (RXRATE = HIGH)	5.66	52.28	ns
t_{RXCLKD}	RXCLKx Duty Cycle centered at 50%	-1.0	+1.0	ns
$t_{RXCLKR}^{[25]}$	RXCLKx Rise Time	0.3	1.2	ns
$t_{RXCLKF}^{[25]}$	RXCLKx Fall Time	0.3	1.2	ns
$t_{RXDV-}^{[28]}$	Status and Data Valid Time to RXCLKx	5UI - 1.5		ns
	Status and Data Valid Time to RXCLKx (HALF RATE RECOVERED CLOCK)	5UI - 1.0		ns
$t_{RXDV+}^{[28]}$	Status and Data Valid Time from RXCLKx	5UI - 1.8		ns
	Status and Data Valid Time from RXCLKx (HALF RATE RECOVERED CLOCK)	5UI - 2.3		ns

CYP(V)15G0402DXB REFCLK Switching Characteristics Over the Operating Range

Parameter	Description	Min.	Max.	Unit
f_{REF}	REFCLK Clock Frequency	19.5	150	MHz
t_{REFCLK}	REFCLK Period	6.6	51.28	ns
t_{REFH}	REFCLK HIGH Time (TXRATE = HIGH)	5.9		ns
	REFCLK HIGH Time (TXRATE = LOW)	2.9 ^[25]		ns
t_{REFL}	REFCLK LOW Time (TXRATE = HIGH)	5.9		ns
	REFCLK LOW Time (TXRATE = LOW)	2.9 ^[25]		ns

Notes:

25. Tested initially and after any design or process changes that may affect these parameters, but not 100% tested.
 26. The ratio of rise time to falling time must not vary by greater than 2:1.
 27. For a given operating frequency, neither rise or fall specification can be greater than 20% of the clock-cycle period or the data sheet maximum time.
 28. Parallel data output specifications are only valid if all inputs or outputs are loaded with similar DC and AC loads.

CYP(V)15G0402DXB REFCLK Switching Characteristics Over the Operating Range (continued)

Parameter	Description	Min.	Max.	Unit
t_{REFD} [29]	REFCLK Duty Cycle	30	70	%
t_{REFR} [25, 26, 27]	REFCLK Rise Time (20% – 80%)		2	ns
t_{REFF} [25, 26, 27]	REFCLK Fall Time (20% – 80%)		2	ns
t_{TREFDS}	Transmit Data Setup Time to REFCLK (TXCKSEL = LOW)	1.7		ns
t_{TREFDH}	Transmit Data Hold Time from REFCLK (TXCKSEL = LOW)	0.8		ns
t_{REFRX} [8]	REFCLK Frequency Referenced to Received Clock Period	-1500	+1500	ppm

CYP(V)15G0402DXB Transmit Serial Outputs and TX PLL Characteristics Over the Operating Range

Parameter	Description	Condition	Min.	Max.	Unit
t_B	Bit Time		5100	660	ps
t_{RISE} [25]	CML Output Rise Time 20% – 80% (CML Test Load)	SPDSEL = HIGH	50	270	ps
		SPDSEL = MID	100	500	ps
		SPDSEL = LOW	180	1000	ps
t_{FALL} [25]	CML Output Fall Time 80% – 20% (CML Test Load)	SPDSEL = HIGH	50	270	ps
		SPDSEL = MID	100	500	ps
		SPDSEL = LOW	180	1000	ps
t_{DJ} [25, 30, 32]	Deterministic Jitter (peak-peak)	IEEE 802.3z		25	ps
t_{RJ} [25, 31, 32]	Random Jitter (σ)	IEEE 802.3z		11	ps
t_{TXLOCK}	Transmit PLL lock to REFCLK			200	us

CYP(V)15G0402DXB Receive Serial Inputs and CDR PLL Characteristics Over the Operating Range

t_{RXLOCK}	Receive PLL lock to input data stream (cold start)			376K	UI [33]
	Receive PLL lock to input data stream			376K	UI
$t_{RXUNLOCK}$	Receive PLL Unlock Rate			46	UI
t_{JTOL}	Total Jitter Tolerance	IEEE 802.3z	600		ps
t_{DJTOL}	Deterministic Jitter Tolerance	IEEE 802.3z	370		ps

Capacitance [25]

Parameter	Description	Test Conditions	Max.	Unit
C_{INTTL}	TTL Input Capacitance	$T_A = 25^\circ\text{C}$, $f_0 = 1\text{ MHz}$, $V_{CC} = 3.3\text{V}$	7	pF
C_{INPECL}	PECL input Capacitance	$T_A = 25^\circ\text{C}$, $f_0 = 1\text{ MHz}$, $V_{CC} = 3.3\text{V}$	4	pF

Notes:

29. The duty cycle specification is a simultaneous condition with the t_{REFH} and t_{REFL} parameters. This means that at faster character rates the REFCLK duty cycle cannot be as large as 30% – 70%.
30. While sending continuous K28.5s, outputs loaded to a balanced 100Ω load, measured at the cross point of differential outputs, over the operating range.
31. While sending continuous K28.7s, after 100,000 samples measured at the cross point of differential outputs, time referenced to REFCLK input, over the operating range.
32. Total jitter is calculated at an assumed BER of $1E-12$. Hence: total jitter (t_j) = $(t_{RJ} * 14) + t_{DJ}$.
33. Receiver UI (Unit Interval) is calculated as $1 / (f_{REF} * 20)$ (when RXRATE = HIGH) or $1 / (f_{REF} * 10)$ (when RXRATE = LOW) if no data is being received, or $1 / (f_{REF} * 20)$ (when RXRATE = HIGH) or $1 / (f_{REF} * 10)$ (when RXRATE = LOW) of the remote transmitter if data is being received. In an operating link this is equivalent to t_B .

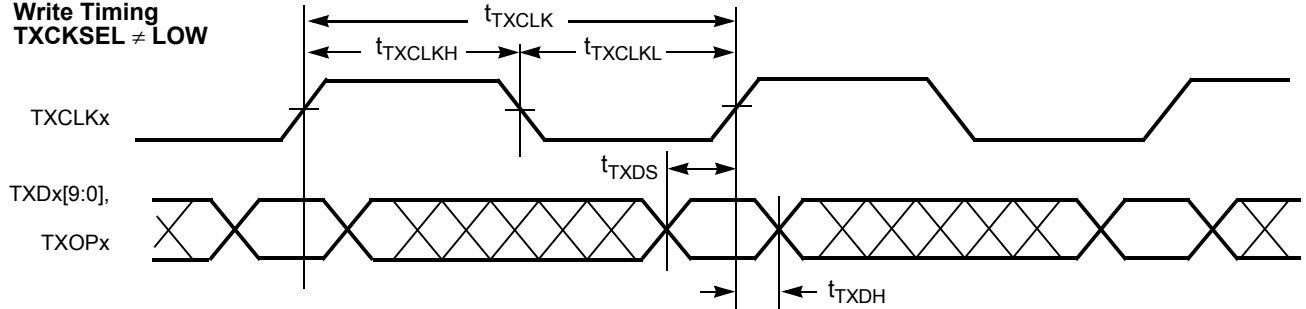
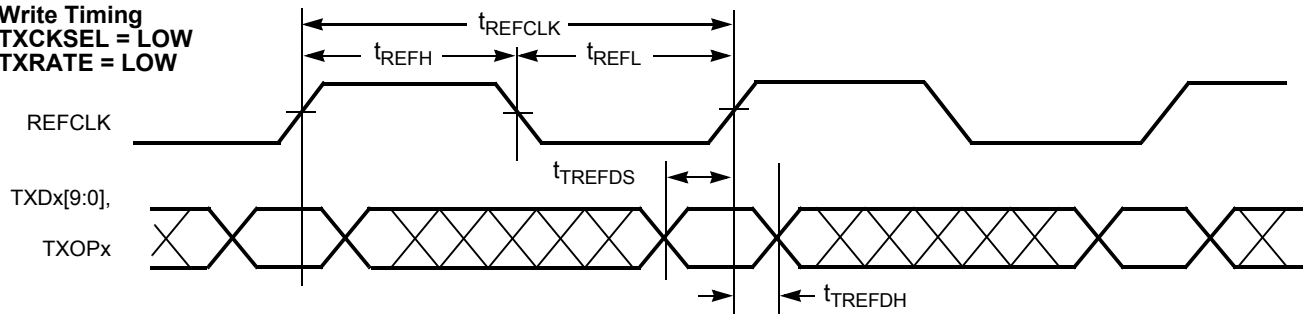
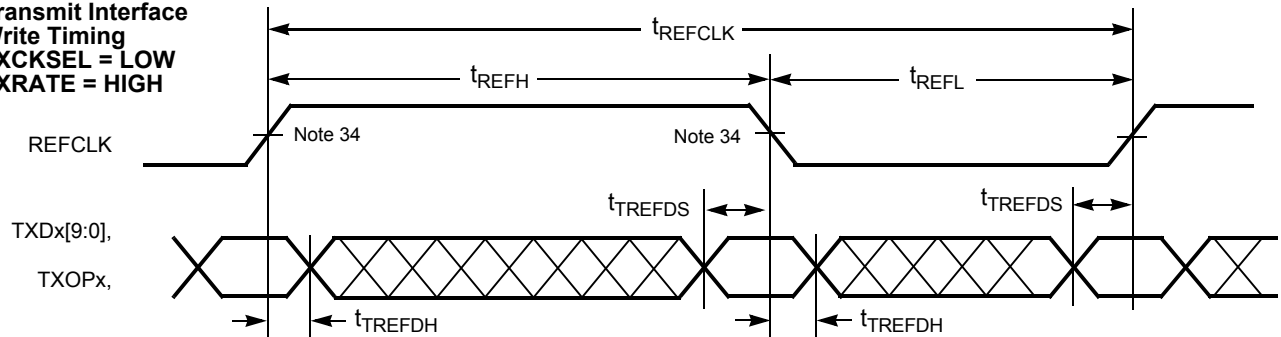
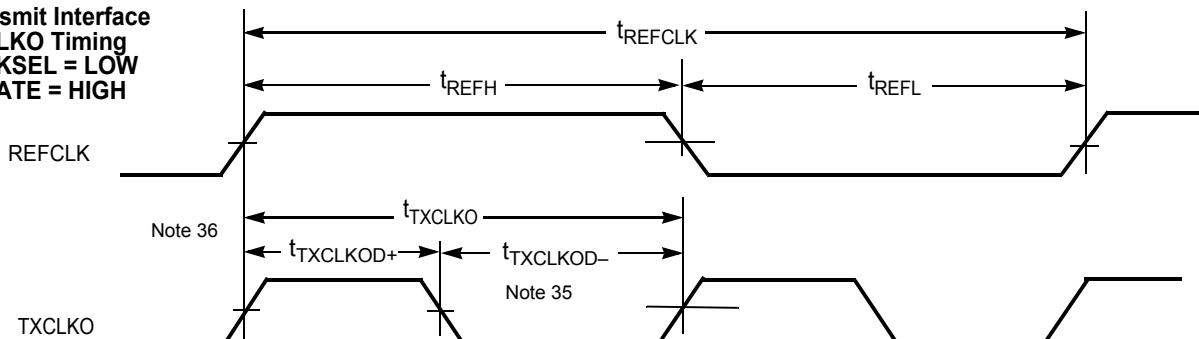
CYP(V)15G0402DXB HOTLink II Transmitter Switching Waveforms
**Transmit Interface
Write Timing
TXCKSEL ≠ LOW**

**Transmit Interface
Write Timing
TXCKSEL = LOW
TXRATE = LOW**

**Transmit Interface
Write Timing
TXCKSEL = LOW
TXRATE = HIGH**

**Transmit Interface
TXCLKO Timing
TXCKSEL = LOW
TXRATE = HIGH**

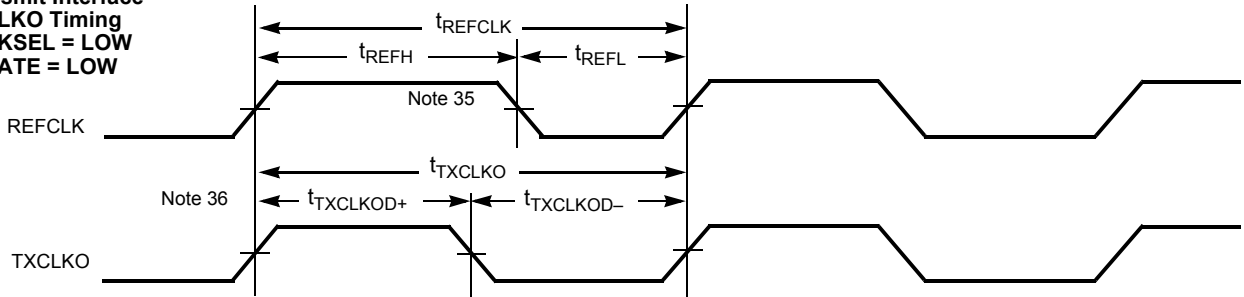
Notes:

34. When REFCLK is configured for half-rate operation (TXRATE = HIGH) and data is captured using REFCLK instead of a TXCLKx clock (TXCKSEL = LOW), data is captured using both the rising and falling edges of REFCLK.
35. The TXCLKO output is at twice the rate of REFCLK when TXRATE = HIGH and same rate as REFCLK when TXRATE = LOW. TXCLKO does not follow the duty cycle of REFCLK.
36. The rising edge of TXCLKO output has no direct phase relationship to the REFCLK input.

CYP(V)15G0402DXB HOTLink II Transmitter Switching Waveforms (continued)

Transmit Interface
TXCLKO Timing
TXCKSEL = LOW
TXRATE = LOW

Switching Waveforms for the CYP(V)15G0402DXB HOTLink II Receiver

Receive Interface
Read Timing

RXRATE = LOW

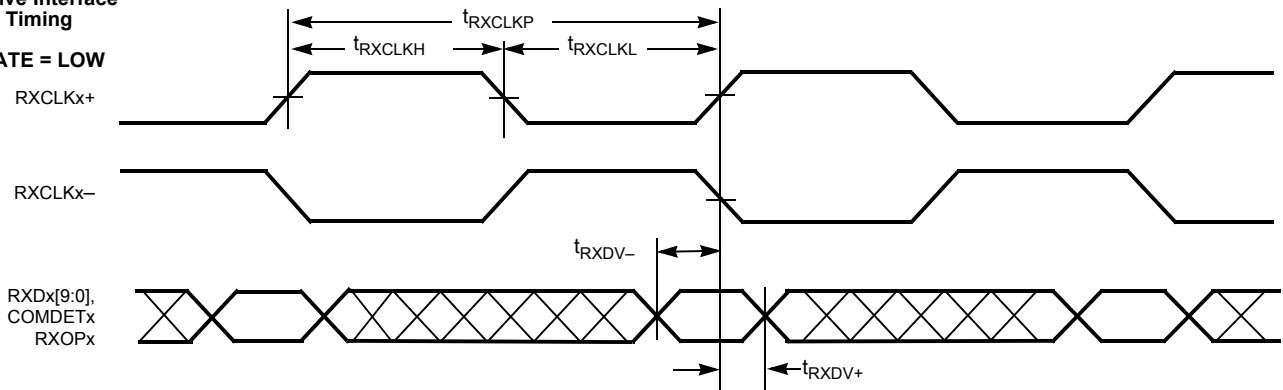

Receive Interface
Read Timing

RXRATE = HIGH

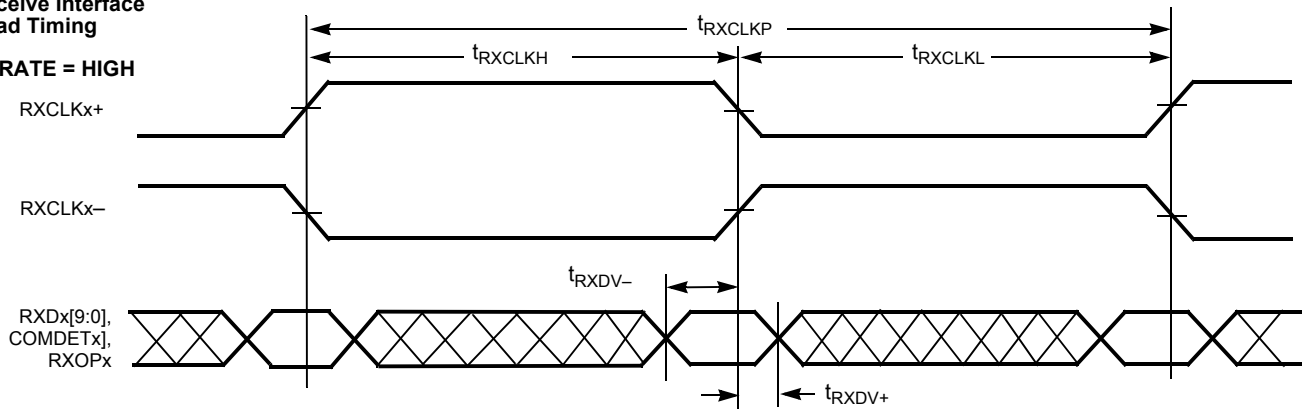

Table 9. Package Coordinate Signal Allocation

Ball ID	Signal Name	Signal Type	Ball ID	Signal Name	Signal Type	Ball ID	Signal Name	Signal Type
A01	INC-	CML IN	C04	LPENB	LVTTTL IN	E19	VCC	POWER
A02	OUTC-	CML OUT	C05	VCC	POWER	E20	VCC	POWER
A03	N/C	NO CONNECT	C06	PARCTL	3-LEVEL SEL	F01	TXPERC	LVTTTL OUT
A04	N/C	NO CONNECT	C07	SDASEL	3-LEVEL SEL	F02	TXOPC	LVTTTL IN PU
A05	VCC	POWER	C08	GND	GROUND	F03	TXDC[0]	LVTTTL IN
A06	IND-	CML IN	C09	BOE[7]	LVTTTL IN PU	F04	N/C	NO CONNECT
A07	OUTD-	CML OUT	C10	BOE[5]	LVTTTL IN PU	F17	BISTLE	LVTTTL IN PU
A08	GND	GROUND	C11	BOE[3]	LVTTTL IN PU	F18	RXDB[0]	LVTTTL OUT
A09	N/C	NO CONNECT	C12	BOE[1]	LVTTTL IN PU	F19	RXOPB	LVTTTL 3-S OUT
A10	N/C	CML OUT	C13	GND	GROUND	F20	RXDB[1]	LVTTTL OUT
A11	INA-	CML IN	C14	GND	GROUND	G01	TXDC[7]	LVTTTL IN
A12	OUTA-	CML OUT	C15	GND	GROUND	G02	TXCKSEL	3-LEVEL SEL
A13	GND	GROUND	C16	VCC	POWER	G03	TXDC[4]	LVTTTL IN
A14	N/C	NO CONNECT	C17	TXRATE	LVTTTL IN PD	G04	TXDC[1]	LVTTTL IN
A15	N/C	NO CONNECT	C18	RXRATE	LVTTTL IN PD	G17	GND	GROUND
A16	VCC	POWER	C19	N/C	NO CONNECT	G18	OELE	LVTTTL IN PU
A17	INB-	CML IN	C20	TDO	LVTTTL 3-S OUT	G19	FRAMCHAR	3-LEVEL SEL
A18	OUTB-	CML OUT	D01	TCLK	LVTTTL IN PD	G20	RXDB[3]	LVTTTL OUT
A19	N/C	NO CONNECT	D02	TRSTZ	LVTTTL IN PU	H01	GND	GROUND
A20	N/C	NO CONNECT	D03	LPEND	LVTTTL IN	H02	GND	GROUND
B01	INC+	CML IN	D04	LPENA	LVTTTL IN	H03	GND	GROUND
B02	OUTC+	CML OUT	D05	VCC	POWER	H04	GND	GROUND
B03	N/C	NO CONNECT	D06	RFMODE	3-LEVEL SEL	H17	GND	GROUND
B04	N/C	NO CONNECT	D07	SPDSEL	3-LEVEL SEL	H18	GND	GROUND
B05	VCC	POWER	D08	GND	GROUND	H19	GND	GROUND
B06	IND+	CML IN	D09	BOE[6]	LVTTTL IN PU	H20	GND	GROUND
B07	OUTD+	CML OUT	D10	BOE[4]	LVTTTL IN PU	J01	TXDC[9]	LVTTTL IN
B08	GND	GROUND	D11	BOE[2]	LVTTTL IN PU	J02	TXDC[5]	LVTTTL IN
B09	N/C	NO CONNECT	D12	BOE[0]	LVTTTL IN PU	J03	TXDC[2]	LVTTTL IN
B10	N/C	NO CONNECT	D13	GND	GROUND	J04	TXDC[3]	LVTTTL IN
B11	INA+	CML IN	D14	GND	GROUND	J17	COMDET B	LVTTTL OUT
B12	OUTA+	CML OUT	D15	GND	GROUND	J18	RXDB[2]	LVTTTL OUT
B13	GND	GROUND	D16	VCC	POWER	J19	RXDB[7]	LVTTTL OUT
B14	N/C	NO CONNECT	D17	N/C	NO CONNECT	J20	RXDB[4]	LVTTTL OUT
B15	N/C	NO CONNECT	D18	RXLE	LVTTTL IN PU	K01	RXDC[4]	LVTTTL OUT
B16	VCC	POWER	D19	N/C	NO CONNECT	K02	RXCLKC-	LVTTTL OUT
B17	INB+	CML IN	D20	N/C	NO CONNECT	K03	TXDC[8]	LVTTTL IN
B18	OUTB+	CML OUT	E01	VCC	POWER	K04	LFIC	LVTTTL OUT
B19	N/C	NO CONNECT	E02	VCC	POWER	K17	RXDB[5]	LVTTTL OUT
B20	N/C	NO CONNECT	E03	VCC	POWER	K18	RXDB[6]	LVTTTL OUT
C01	TDI	LVTTTL IN PU	E04	VCC	POWER	K19	RXDB[9]	LVTTTL OUT
C02	TMS	LVTTTL IN PU	E17	VCC	POWER	K20	RXCLKB+	LVTTTL I/O PD
C03	LPENC	LVTTTL IN	E18	VCC	POWER	L01	RXDC[5]	LVTTTL OUT

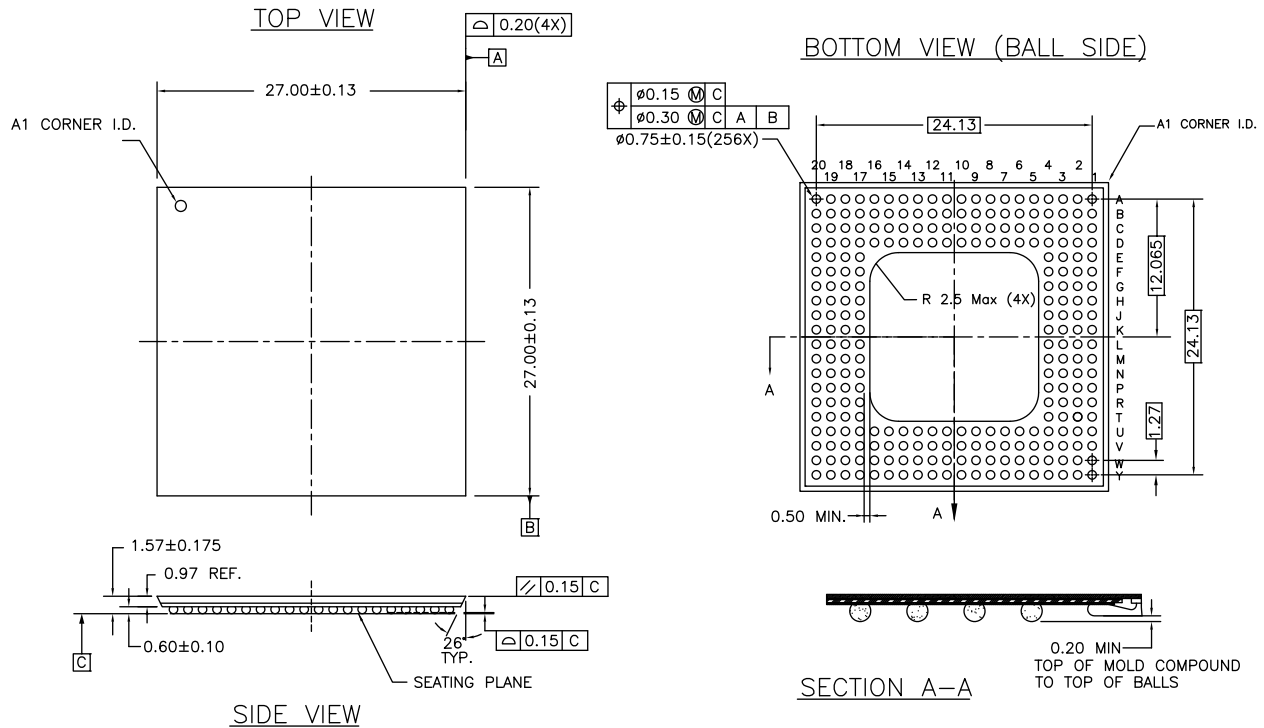

Table 9. Package Coordinate Signal Allocation (continued)

Ball ID	Signal Name	Signal Type	Ball ID	Signal Name	Signal Type	Ball ID	Signal Name	Signal Type
L02	RXCLKC+	LVTTTL I/O PD	T17	VCC	POWER	V20	RXDA[1]	LVTTTL OUT
L03	TXCLKC	LVTTTL IN PD	T18	VCC	POWER	W01	TXDD[5]	LVTTTL IN
L04	TXDC[6]	LVTTTL IN	T19	VCC	POWER	W02	TXDD[7]	LVTTTL IN
L17	RXDB[8]	LVTTTL OUT	T20	VCC	POWER	W03	LFID	LVTTTL OUT
L18	LFIB	LVTTTL OUT	U01	TXDD[0]	LVTTTL IN	W04	RXCLKD-	LVTTTL OUT
L19	RXCLKB-	LVTTTL OUT	U02	TXDD[1]	LVTTTL IN	W05	VCC	POWER
L20	TXDB[6]	LVTTTL IN	U03	TXDD[2]	LVTTTL IN	W06	RXDD[6]	LVTTTL OUT
M01	RXDC[6]	LVTTTL OUT	U04	TXDD[9]	LVTTTL IN	W07	RXDD[0]	LVTTTL OUT
M02	RXDC[7]	LVTTTL OUT	U05	VCC	POWER	W08	GND	GROUND
M03	RXDC[9]	LVTTTL OUT	U06	RXDD[4]	LVTTTL OUT	W09	TXCLKO-	LVTTTL OUT
M04	RXDC[8]	LVTTTL OUT	U07	RXDD[3]	LVTTTL OUT	W10	TXRST	LVTTTL IN PU
M17	TXDB[9]	LVTTTL IN	U08	GND	GROUND	W11	TXOPA	LVTTTL IN PU
M18	TXDB[8]	LVTTTL IN	U09	RXOPD	LVTTTL 3-S OUT	W12	RFENA	LVTTTL IN PD
M19	TXDB[7]	LVTTTL IN	U10	RFENC	LVTTTL IN PD	W13	GND	GROUND
M20	TXCLKB	LVTTTL IN PD	U11	REFCLK-	PECL IN	W14	TXDA[2]	LVTTTL IN
N01	GND	GROUND	U12	TXDA[1]	LVTTTL IN	W15	TXDA[6]	LVTTTL IN
N02	GND	GROUND	U13	GND	GROUND	W16	VCC	POWER
N03	GND	GROUND	U14	TXDA[4]	LVTTTL IN	W17	LFIA	LVTTTL OUT
N04	GND	GROUND	U15	TXDA[8]	LVTTTL IN	W18	RXCLKA-	LVTTTL OUT
N17	GND	GROUND	U16	VCC	POWER	W19	RXDA[6]	LVTTTL OUT
N18	GND	GROUND	U17	RXDA[4]	LVTTTL OUT	W20	RXDA[3]	LVTTTL OUT
N19	GND	GROUND	U18	RXOPA	LVTTTL OUT	Y01	TXDD[6]	LVTTTL IN
N20	GND	GROUND	U19	COMDETA	LVTTTL OUT	Y02	TXCLKD	LVTTTL IN
P01	RXDC[3]	LVTTTL OUT	U20	RXDA[0]	LVTTTL OUT	Y03	RXDD[9]	LVTTTL OUT
P02	RXDC[2]	LVTTTL OUT	V01	TXDD[3]	LVTTTL IN	Y04	RXCLKD+	LVTTTL I/O PD
P03	RXDC[1]	LVTTTL OUT	V02	TXDD[4]	LVTTTL IN	Y05	VCC	POWER
P04	RXDC[0]	LVTTTL OUT	V03	TXDD[8]	LVTTTL IN	Y06	RXDD[7]	LVTTTL OUT
P17	TXDB[5]	LVTTTL IN	V04	RXDD[8]	LVTTTL OUT	Y07	RXDD[2]	LVTTTL OUT
P18	TXDB[4]	LVTTTL IN	V05	VCC	POWER	Y08	GND	GROUND
P19	TXDB[3]	LVTTTL IN	V06	RXDD[5]	LVTTTL OUT	Y09	TXCLKO+	LVTTTL OUT
P20	TXDB[2]	LVTTTL IN	V07	RXDD[1]	LVTTTL OUT	Y10	N/C	NO CONNECT
R01	COMDETC	LVTTTL OUT	V08	GND	GROUND	Y11	TXCLKA	LVTTTL IN PD
R02	RXOPC	LVTTTL 3-S OUT	V09	COMDETD	LVTTTL OUT	Y12	TXPERA	LVTTTL OUT
R03	TXPERD	LVTTTL OUT	V10	RFEND	LVTTTL IN PD	Y13	GND	GROUND
R04	TXOPD	LVTTTL IN PU	V11	REFCLK+	PECL IN	Y14	TXDA[0]	LVTTTL IN
R17	TXDB[1]	LVTTTL IN	V12	RFENB	LVTTTL IN PD	Y15	TXDA[5]	LVTTTL IN
R18	TXDB[0]	LVTTTL IN	V13	GND	GROUND	Y16	VCC	POWER
R19	TXOPB	LVTTTL IN PU	V14	TXDA[3]	LVTTTL IN	Y17	TXDA[9]	LVTTTL IN
R20	TXPERB	LVTTTL OUT	V15	TXDA[7]	LVTTTL IN	Y18	RXCLKA+	LVTTTL I/O PD
T01	VCC	POWER	V16	VCC	POWER	Y19	RXDA[8]	LVTTTL OUT
T02	VCC	POWER	V17	RXDA[9]	LVTTTL OUT	Y20	RXDA[7]	LVTTTL OUT
T03	VCC	POWER	V18	RXDA[5]	LVTTTL OUT			
T04	VCC	POWER	V19	RXDA[2]	LVTTTL OUT			

Ordering Information

Speed	Ordering Code	Package Name	Package Type	Operating Range
Standard	CYP15G0402DXB-BGXC	BL256	Pb-Free 256-ball Thermally Enhanced Ball Grid Array	Commercial
Standard	CYV15G0402DXB-BGXC	BL256	Pb-Free 256-ball Thermally Enhanced Ball Grid Array	Commercial

Package Diagram

51-85123 *F



HOTLink is a registered trademark, and HOTLink II and MultiFrame are trademarks, of Cypress Semiconductor Corporation. ESCON is a registered trademark of International Business Machines. All product and company names mentioned in this document are the trademarks of their respective holders.

Document History Page

Document Title: CYP(V)15G0402DXB Quad HOTLink II™ SERDES				
Document Number: 38-02057				
REV.	ECN NO.	Issue Date	Orig. of Change	Description of Change
**	116285	07/16/02	SDR	New Data Sheet
*A	118985	09/30/02	LNM	Changed TXCLKO description Changed TXPERx description introduced SMPTE pathological test clause Removed the LOW setting for FRAMCHAR and related references Changed V _{ODIF} and V _{OLC} for CML output Changed the I _{OST} boundary values Changed the t _{TXCLKR} and t _{TXCLKF} min values Changed t _{TXDS} and t _{TXDH} and t _{TREFDS} and t _{TREFDH} Changed t _{REFADV-} and t _{REFCDV-} and t _{REFCDV+} Changed the JTAG ID from 0C801069 to 1C801069
*B	122545	12/09/02	CGX	Changed Minimum tRISE/tFALL for CML Changed tTXCLKOD+, tTXCLKOD- for LVTTTL Changed tRXLOCK Changed tDJ, tRJ Changed tJTOL Changed tTXLOCK Changed tRXCLKH, tRXCLKL Changed Power Specs Changed verbiage...Paragraph: Clock/Data Recovery Changed verbiage...Paragraph: Range Control Updated differences to pin configuration and pin table Added Power-up Requirements
*C	122211	12/28/02	RBI	Minor change Document Control corrected Document History Page
*D	124992	04/15/03	POT	Changed CYP15G0402DXB to CYP(V)15G0402DXB type corresponding to Video-compliant parts Reduced the lower limit of the serial signaling rate from 200 Mbaud to 195 Mbaud and changed the associated specifications accordingly
*E	128367	07/24/03	PDS	Added t _{RXDV+} timing parameter Removed irrelevant timing parameters
*F	131899	01/21/04	PDS	When TXCKSEL = MID or HIGH, TXRATE = HIGH is an invalid mode. Made appropriate changes to reflect this invalid condition Changed LFIx to Asynchronous output Expanded the CDR Range Controller's permissible frequency offset between incoming serial signaling rate and Reference clock from ±200-PPM to ±1500-PPM (changed parameter t _{REFRX}) Revised Typical Power numbers to match final characterization data
*G	338721	See ECN	SUA	Added Pb-Free Package option availability Changed MBd to MBaud in SPDSEL pin description
*H	2898393	03/24/10	CGX	Removed inactive parts from the ordering information table. Updated package diagram.

Looking for pricing, stock, or lifecycle information?

Click below to explore more details on WIN SOURCE:

-  [View CYP15G0402DXB-BGXC on WIN SOURCE](#)
-  [Cypress Semiconductor Corp Information](#)

Optimize Your Supply Chain with WIN SOURCE Solutions

-  Global Sourcing Solution
-  Obsolete Management
-  Cost Control Management
-  Shortage Management
-  Alternative Solution
-  Excess Inventory Management