



THE DATASHEET OF CY2CC9100XIT



1:10 Clock Fanout Buffer

Features

- Low voltage operation
- Full range support:
 - 3.3 V
 - 2.5 V
 - 1.8 V
- Over voltage tolerant input hot swappable
- 1:10 Fanout
- Drives either a 50-Ohm or 75-Ohm load
- Low input capacitance
- Low output skew
- Low propagation delay
- Typical (t_{pd} less than 4 ns)
- High speed operation:
 - 200 MHz at 1.8 V
 - 650 MHz at 2.5 V and 3.3 V

- Industrial temperature range
- Available in SSOP package

Functional Description

The Cypress series of network circuits are produced using advanced 0.35 micron CMOS technology, achieving the industry's fastest logic and buffers.

The Cypress CY2CC910 fanout buffer features one input and 10 outputs. It is ideal for conversion from and to 3.3 V, 2.5 V, and 1.8 V.

Designed for Data Communications clock management applications, the large fanout from a single input reduces loading on the input clock.

For a complete list of related documentation, [click here](#).

Logic Block Diagram

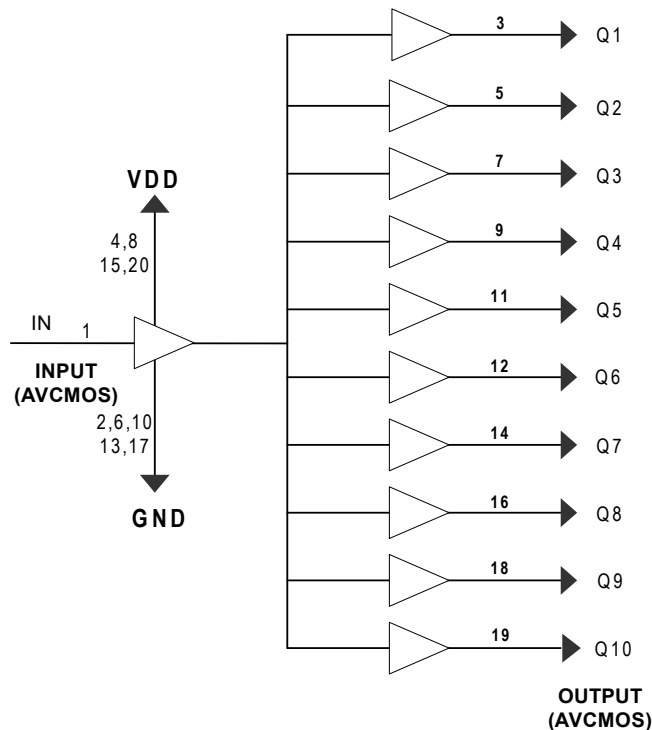

Contents

Pin Configuration	3	Parameter Measurement Information:	
Pin Description	3	VDD at 8 V	9
Maximum Ratings	4	Ordering Information	10
DC Electrical Characteristics	4	Ordering Code Definitions	10
DC Electrical Characteristics	4	Package Diagram	11
DC Electrical Characteristics	5	Acronyms	12
Capacitance	5	Document Conventions	12
Thermal Resistance	5	Units of Measure	12
Power Supply Characteristics	5	Document History Page	13
High Frequency Parametrics	6	Sales, Solutions, and Legal Information	14
AC Switching Characteristics	7	Worldwide Sales and Design Support	14
AC Switching Characteristics	7	Products	14
AC Switching Characteristics	7	PSoC® Solutions	14
Parameter Measurement Information:		Cypress Developer Community	14
VDD at 3.3 V to 2.5 V	8	Technical Support	14

Pin Configuration

Figure 1. 20-pin SOIP/SSOP pinout

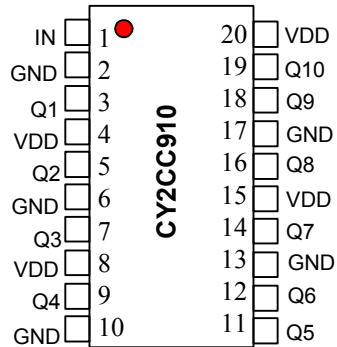

20 pin SOIC/SSOP

Pin Description

Pin Number	Pin Name	Description
1	IN	Input
2, 6, 10, 13, 17	GND	Ground
4, 8, 15, 20	V _{DD}	Power Supply
3, 5, 7, 9, 11, 12, 14, 16, 18, 19	Q1, Q2, Q3, Q4, Q5, Q6, Q7, Q8, Q9, Q10	Output

Maximum Ratings

Exceeding maximum ratings^[1] may shorten the useful life of the device. User guidelines are not tested.

Storage temperature: -65° C to +150° C
 Ambient temperature: -40° C to +85° C
 Supply voltage to ground potential

V_{CC} -0.5 V to 4.6 V
 Input -0.5 V to 5.8 V
 Supply voltage to ground potential
 (Outputs only) -0.5 V to $V_{DD} + 1$ V
 DC output voltage -0.5 V to $V_{DD} + 1$ V
 Power dissipation 0.75 W

DC Electrical Characteristics

At 3.3 V (See Figure 2)

Parameter	Description	Conditions	Min	Typ	Max	Unit
V_{OH}	Output high voltage	$V_{DD} = \text{Min}, V_{IN} = V_{IH}$ or V_{IL} $I_{OH} = -12$ mA	2.3	–	–	V
V_{OL}	Output low voltage	$V_{DD} = \text{Min}, V_{IN} = V_{IH}$ or V_{IL} $I_{OL} = 12$ mA	–	–	0.5	V
V_{IH}	Input high voltage	Guaranteed Logic High Level	2	–	5.8	V
V_{IL}	Input low voltage	Guaranteed Logic Low Level	–	–	0.8	V
I_{IH}	Input high current	$V_{DD} = \text{Max}$ $V_{IN} = 2.7$ V	–	–	1	μA
I_{IL}	Input low current	$V_{DD} = \text{Max}$ $V_{IN} = 0.5$ V	–	–	-1	μA
I_I	Input high current	$V_{DD} = \text{Max}, V_{IN} = V_{DD}(\text{Max})$	–	–	20	μA
V_{IK}	Clamp diode voltage	$V_{DD} = \text{Min}, I_{IN} = -18$ mA	–	-0.7	-1.2	V
I_{OK}	Continuous clamp current	$V_{DD} = \text{Max}, V_{OUT} = \text{GND}$	–	–	-50	mA
O_{OFF}	Power-down disable	$V_{DD} = \text{GND}, V_{OUT} = < 4.5$ V	–	–	100	μA
V_H	Input hysteresis		–	80	–	mV

DC Electrical Characteristics

At 2.5 V (See Figure 2)

Parameter	Description	Conditions	Min	Typ	Max	Unit
V_{OH}	Output high voltage	$V_{DD} = \text{Min}, V_{IN} = V_{IH}$ or V_{IL} $I_{OH} = -7$ mA	1.8	–	–	V
		$I_{OH} = 12$ mA	1.6	–	–	V
V_{OL}	Output low voltage	$V_{DD} = \text{Min}, V_{IN} = V_{IH}$ or V_{IL} $I_{OL} = 12$ mA		–	0.65	V
V_{IH}	Input high voltage	Guaranteed Logic High Level	1.6	–	5.0	V
V_{IL}	Input low voltage	Guaranteed Logic Low Level	–	–	0.8	V
I_{IH}	Input high current	$V_{DD} = \text{Max}$ $V_{IN} = 2.4$ V	–	–	1	μA
I_{IL}	Input low current	$V_{DD} = \text{Max}$ $V_{IN} = 0.5$ V	–	–	-1	μA
I_I	Input high current	$V_{DD} = \text{Max}, V_{IN} = V_{DD}(\text{Max})$	–	–	20	μA
V_{IK}	Clamp diode voltage	$V_{DD} = \text{Min}, I_{IN} = -18$ mA	–	-0.7	-1.2	V
I_{OK}	Continuous clamp current	$V_{DD} = \text{Max}, V_{OUT} = \text{GND}$	–	–	-50	mA
O_{OFF}	Power down disable	$V_{DD} = \text{GND}, V_{OUT} = < 4.5$ V	–	–	100	μA
V_H	Input hysteresis		–	80	–	mV

Note

1. Stresses greater than those listed under absolute maximum ratings may cause permanent damage to the device. This is intended to be a stress rating only and functional operation of the device at these or any other conditions above those indicated in the operation sections of this specification is not implied. Exposure to absolute maximum rating conditions for extended periods may affect reliability.

DC Electrical Characteristics

At 1.8 V (See [Figure 6](#))

Parameter	Description	Test Condition ^[2]	Min	Max	Unit
V _{DD}	Supply voltage		1.71	1.89	V
V _{IH}	Input high voltage		0.65 × V _{DD} [1.1]	4.3	V
V _{IL}	Input low voltage		-0.3	0.35 × V _{DD} [0.6]	V
V _{OH}	Output high voltage	I _{OH} = -2 mA	V _{DD} - 0.45 [1.2]	-	V
V _{OL}	Output low voltage	I _{OH} = 2 mA	-	0.45	V

Capacitance

Parameter ^[3]	Description	Test Conditions	Typ	Max	Unit
C _{IN}	Input capacitance	V _{IN} = 0 V	2.5	-	pF
C _{OUT}	Output capacitance	V _{OUT} = 0 V	6.5	-	pF

Thermal Resistance

Parameter ^[3]	Description	Test Conditions	20-pin SSOP	Unit
θ _{JA}	Thermal resistance (junction to ambient)	Test conditions follow standard test methods and procedures for measuring thermal impedance, in accordance with EIA/JESD51.	79	°C/W
θ _{JC}	Thermal resistance (junction to case)		35	°C/W

Power Supply Characteristics

(See [Figure 2](#))

Parameter	Description	Test Conditions	Min	Typ	Max	Unit
ΔI _{CC}	Delta I _{CC} Quiescent Power Supply Current	(I _{DD} @ V _{DD} = Max and V _{IN} = V _{DD}) - (I _{DD} @ V _{DD} = Max and V _{IN} = V _{DD} - 0.6 V 6 V)	-	-	50	μA
I _{CCD}	Dynamic power supply current	V _{DD} = Max Input toggling 50% Duty Cycle, Outputs Open	-	-	0.63	mA/ MHz
I _C	Total power supply current	V _{DD} = Max Input toggling 50% Duty Cycle, Outputs Open, f _L = 40 MHz	-	-	25	mA

Notes

2. Test load conditions: 500-Ohm to ground with approximately 6-pF total loading and 200-MHz maximum frequency.
3. These parameters are guaranteed by design and are not tested.

High Frequency Parametrics

Parameter	Description	Test Conditions	Min	Typ	Max	Unit
D _J	Jitter, Deterministic	50% duty cycle t _W (50–50) The “point to point load circuit” Output Jitter – Input Jitter	See Figure 4	–	–	20 ps
F _{max} 3.3 V	Maximum frequency V _{DD} = 3.3 V	50% duty cycle t _W (50–50) Standard Load Circuit.	See Figure 2	–	–	160 MHz
		50% duty cycle t _W (50–50) The “point to point load circuit”	See Figure 4	–	–	650
F _{max} 2.5 V	Maximum frequency V _{DD} = 2.5 V	The “point-to-point load circuit” V _{IN} = 2.4 V/0.0 V V _{OUT} = 1.7 V/0.7 V	See Figure 4	–	–	200 MHz
F _{max} 1.8 V	Maximum frequency V _{DD} = 1.8 V	The “6-pF load circuit” V _{IN} = 1.7 V/0.0 V V _{OUT} = 1.2 V/0.4 V	See Figure 6	–	–	200 MHz
F _{max(20)}	Maximum frequency V _{DD} = 3.3 V	20% duty cycle t _W (20–80) The “point to point load circuit” V _{IN} = 3.0 V/0.0 V V _{OUT} = 2.3 V/0.4 V	See Figure 5	–	–	250 MHz
t _W 3.3 V	Minimum pulse V _{DD} = 3.3 V	The “point-to-point load circuit” V _{IN} = 3.0 V/0.0 V F = 100 MHz V _{OUT} = 2.0 V/0.8 V	See Figure 4	1	–	– ns
t _W 2.5 V	Minimum pulse V _{DD} = 2.5 V	The “point-to-point load circuit” V _{IN} = 2.4 V/0.0 V F = 100 MHz V _{OUT} = 1.7 V/0.7 V	See Figure 4	1	–	– ns
t _W 1.8 V	Minimum pulse V _{DD} = 1.8 V	The “6-pF load circuit” V _{IN} = 1.7 V/0.0 V V _{OUT} = 1.2 V/0.4 V	See Figure 6	1	–	– ns

AC Switching Characteristics

At 3.3 V ($V_{DD} = 3.3 \text{ V} \pm 5\%$, Temperature = $-40 \text{ }^\circ\text{C}$ to $+85 \text{ }^\circ\text{C}$)

Parameter	Description		Min	Typ	Max	Unit
t_{PLH}	Propagation delay – Low to High	See Figure 3	1.5	2.7	3.5	ns
t_{PHL}	Propagation delay – High to Low		1.5	2.7	3.5	ns
t_R	Output rise time		–	0.8	–	V/ns
t_F	Output fall time		–	0.8	–	V/ns
$t_{SK(0)}$	Output Skew: Skew between outputs of the same package (in phase).	See Figure 10	–	–	0.2	ns
$t_{SK(p)}$	Pulse Skew: Skew between opposite transitions of the same output ($t_{PHL} - t_{PLH}$).	See Figure 9	–	–	0.2	ns
$t_{SK(t)}$	Package Skew: Skew between outputs of different packages at the same power supply voltage, temperature and package type.	See Figure 11	–	–	0.4	ns

AC Switching Characteristics

At 2.5 V ($V_{DD} = 2.5 \text{ V} \pm 5\%$, Temperature = $-40 \text{ }^\circ\text{C}$ to $+85 \text{ }^\circ\text{C}$)

Parameter	Description		Min	Typ	Max	Unit
t_{PLH}	Propagation delay – Low to High	See Figure 3	1.5	2.7	3.5	ns
t_{PHL}	Propagation delay – High to Low		1.5	2.7	3.5	ns
t_R	Output rise time		–	0.8	–	V/ns
t_F	Output fall time		–	0.8	–	V/ns
$t_{SK(0)}$	Output Skew: Skew between outputs of the same package (in phase).	See Figure 10	–	–	0.2	ns
$t_{SK(p)}$	Pulse Skew: Skew between opposite transitions of the same output ($t_{PHL} - t_{PLH}$).	See Figure 9	–	–	0.2	ns
$t_{SK(t)}$	Package Skew: Skew between outputs of different packages at the same power supply voltage, temperature and package type.	See Figure 11	–	–	0.4	ns

AC Switching Characteristics

At 1.8 V ($V_{DD} = 1.8 \text{ V} \pm 5\%$, Temperature = $-40 \text{ }^\circ\text{C}$ to $+85 \text{ }^\circ\text{C}$)

Parameter	Description		Min	Typ	Max	Unit
t_{PLH}	Propagation delay – Low to High	See Figure 7	1.5	2.7	3.5	ns
t_{PHL}	Propagation delay – High to Low		1.5	2.7	3.5	ns
t_R	Output rise time 20%–80%		0.2	–	1.5	ns
t_F	Output fall time 20%–80%		0.2	–	1.5	ns
$t_{SK(0)}$	Output Skew: Skew between outputs of the same package (in phase).	See Figure 10	–	–	0.2	ns
$t_{SK(p)}$	Pulse Skew: Skew between opposite transitions of the same output ($t_{PHL} - t_{PLH}$).	See Figure 9	–	–	0.2	ns
$t_{SK(t)}$	Package Skew: Skew between outputs of different packages at the same power supply voltage, temperature and package type.	See Figure 11	–	–	0.4	ns

Parameter Measurement Information: V_{DD} at 3.3 V to 2.5 V

Figure 2. Load Circuit [4, 5, 6]

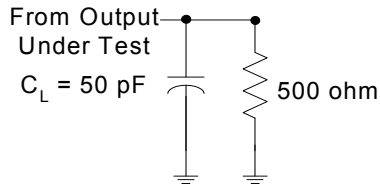

Figure 3. Voltage Waveforms Propagation Delay Times [7]

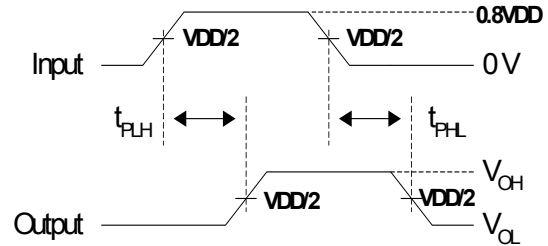

Figure 4. Point to Point Load Circuit [4, 5, 6]

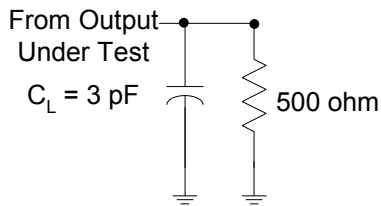
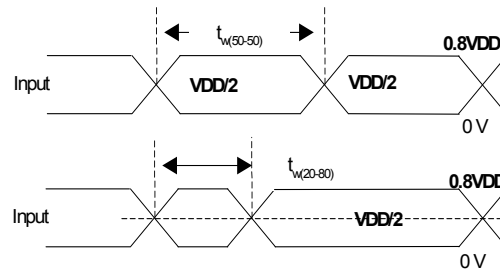

Figure 5. Voltage Waveforms – Pulse Duration [5]



Notes

4. C_L includes probe and jig capacitance.
5. All input pulses are supplied by generators having the following characteristics: PRR < 100 MHz, $Z_0 = 50\Omega$, $t_r < 2.5$ ns, $t_f < 2.5$ ns.
6. The outputs are measured one at a time with one transition per measurement.
7. T_{PLH} and T_{PHL} are the same as t_{pd} .

Parameter Measurement Information: V_{DD} at 8 V

Figure 6. Load Circuit [8, 9, 10]

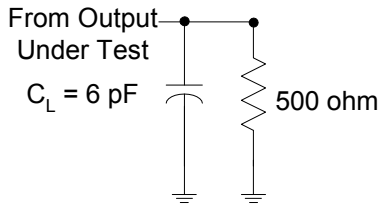

Figure 7. Voltage Waveforms Propagation

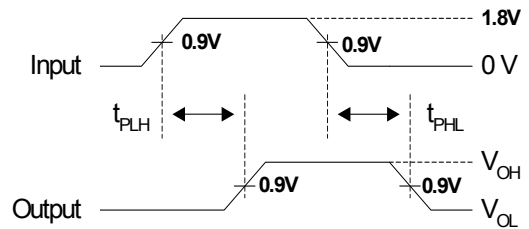

Figure 8. Voltage Waveforms – Pulse Duration [9]

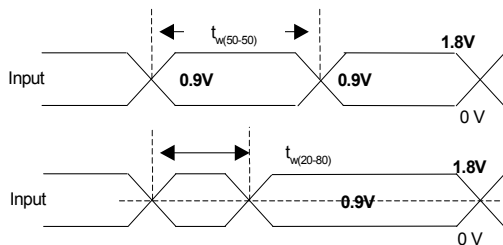

Figure 9. Pulse Skew - tsk_(p)

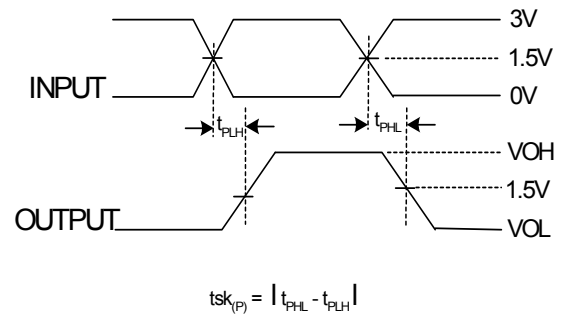
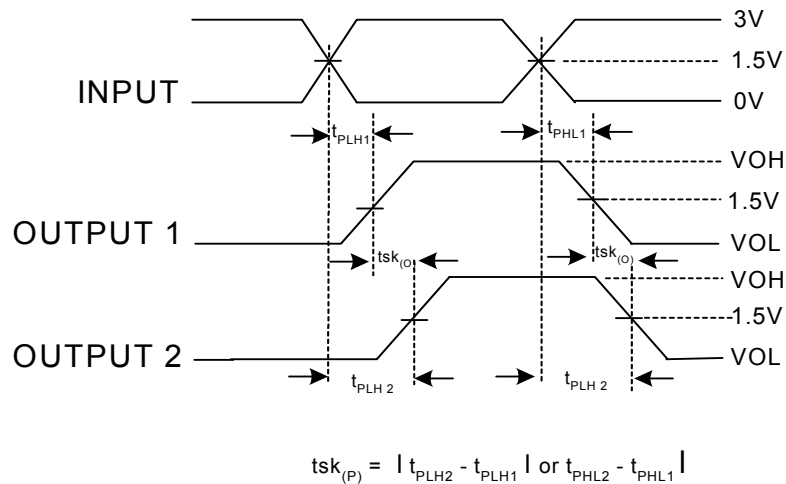

Figure 10. Output Skew - tsk_(o)



Notes

- 8. C_L includes probe and jig capacitance.
- 9. All input pulses are supplied by generators having the following characteristics: PRR < 100 MHz, Z₀ = 50Ω, t_R < 2.5 ns, t_F < 2.5 ns.
- 10. The outputs are measured one at a time with one transition per measurement.

Parameter Measurement Information: V_{DD} at 8 V(continued)

Figure 11. Package Skew - $tsk_{(t)}$

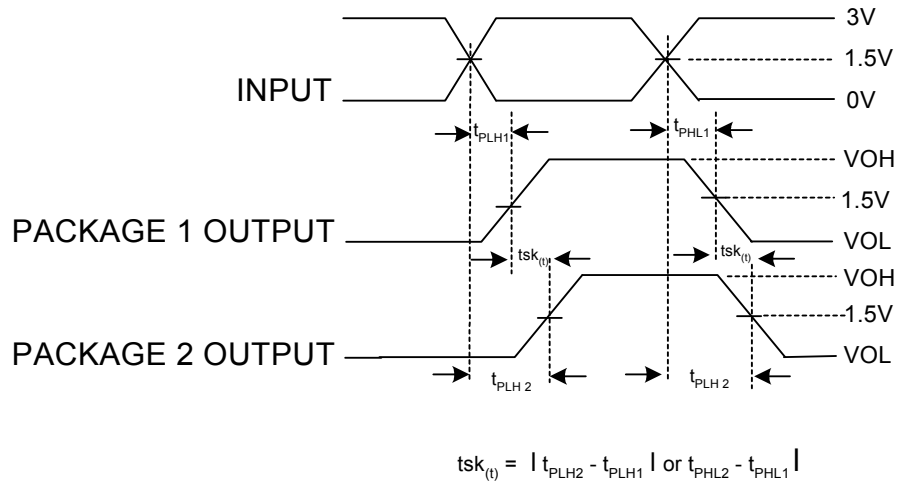

Ordering Information

Part Number	Package Type	Product Flow
Pb-free		
CY2CC910OXI	20-pin SSOP	Industrial, -40° C to 85° C
CY2CC910OXIT	20-pin SSOP – Tape and Reel	Industrial, -40° C to 85° C

Ordering Code Definitions

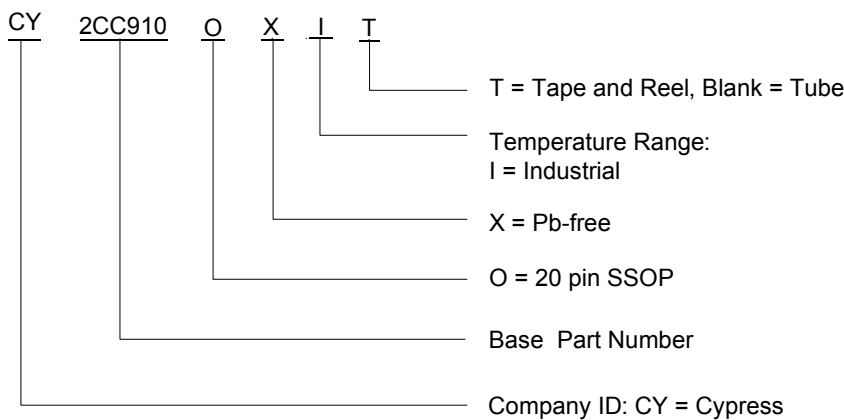

Package Diagram

Figure 12. 20-pin SSOP (210 Mils) O20.21 Package Outline, 51-85077

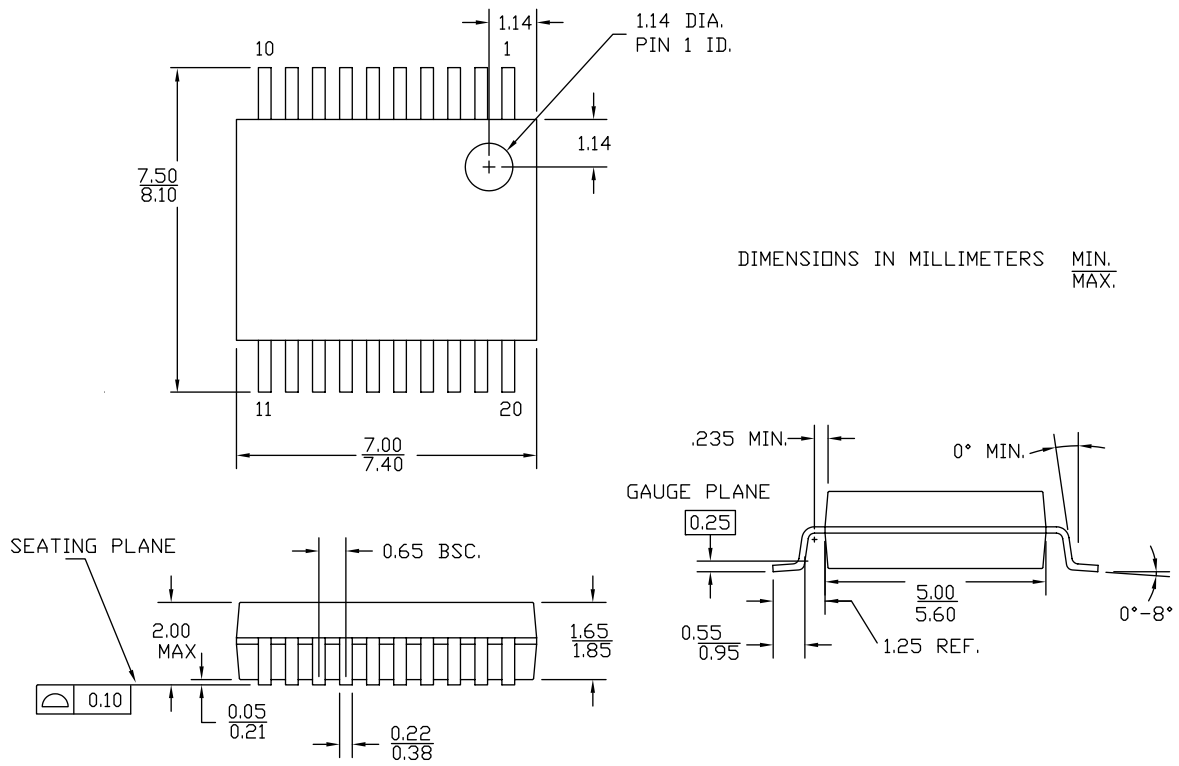

51-85077 *F

Acronyms

Acronym	Description
CMOS	complementary metal oxide semiconductor
DJ	deterministic jitter
SSOP	shrunk small outline package

Document Conventions

Units of Measure

Symbol	Unit of Measure
°C	degree Celsius
MHZ	megahertz
uA	microamperes
mA	milliamperes
ms	milliseconds
ns	nanoseconds
%	percent
pF	picofarads
ps	picoseconds
V	volt

Document History Page

Document Title: CY2CC910, 1:10 Clock Fanout Buffer Document No: 38-07348				
Rev.	ECN No.	Orig. of Change	Submission Date	Description of Change
**	114318	TSM	05/10/02	New data sheet
*A	119148	RGL	10/07/02	Added 5.8 as the Max value for V_{IH} in the DC Electrical Characteristics @3.3 V table. Changed the Max value of V_{IH} from 5.8 to 5.0 in the DC Electrical Characteristics @2.5 V table. Changed the value of V_{IH} from $V_{DD}+0.3$ [2.25] to 4.3 in the DC Electrical Characteristics @1.8 V table.
*B	404287	RGL	See ECN	Added Lead-free devices for SSOP
*C	2595534	CXQ / PYRS	10/23/08	Added "Status" column to Ordering Information table Updated Package Diagram 51-85024 Updated to new template.
*D	2896073	CXQ	03/19/10	Removed SOIC packages related information in all instances across the document. Updated Ordering Information : Removed obsolete parts from ordering information table and added CY2CC910OXI-1, CY2CC910OXI-1T. Updated Package Diagram .
*E	3056154	CXQ	10/08/2010	Updated Ordering Information : Removed CY2CC910OXI-1, CY2CC910OXI-1T, CY2CC910OXC, and CY2CC910OXCT parts. Removed the Note "Devices with part numbers ending with -1 are identical to devices without the -1 suffix. There are no differences in specification." and its reference.
*F	3411742	PURU	10/18/2011	Added Contents . Updated Functional Description : Removed "Cypress employs the unique AVCMOS type outputs VOI (Variable Output Impedance) that dynamically adjust for variable impedance matching, eliminate the need for series damping resistors, and reduce overall noise." Removed "Variable Output Impedance Control (VOI)". Updated Ordering Information Updated Package Diagram . Added Acronyms and Units of Measure .
*G	4575136	TAVA	11/20/2014	Updated Functional Description : Added "For a complete list of related resources, click here ." at the end. Updated to new template. Completing Sunset Review.
*H	4586288	TAVA	12/03/2014	Updated Functional Description : Replaced "resources" with "documentation".
*I	5272946	PSR	05/16/2016	Added Thermal Resistance . Updated Package Diagram : spec 51-85077 – Changed revision from *E to *F. Updated to new template.
*J	5726314	PSR	05/11/2017	Updated DC Electrical Characteristics (At 3.3 V): Removed typical values of V_{OH} and V_{OL} parameters. Updated to new template.

Sales, Solutions, and Legal Information

Worldwide Sales and Design Support

Cypress maintains a worldwide network of offices, solution centers, manufacturer's representatives, and distributors. To find the office closest to you, visit us at [Cypress Locations](#).

Products

ARM® Cortex® Microcontrollers	cypress.com/arm
Automotive	cypress.com/automotive
Clocks & Buffers	cypress.com/clocks
Interface	cypress.com/interface
Internet of Things	cypress.com/iot
Memory	cypress.com/memory
Microcontrollers	cypress.com/mcu
PSoC	cypress.com/psoc
Power Management ICs	cypress.com/pmic
Touch Sensing	cypress.com/touch
USB Controllers	cypress.com/usb
Wireless Connectivity	cypress.com/wireless

PSoC® Solutions

[PSoC 1](#) | [PSoC 3](#) | [PSoC 4](#) | [PSoC 5LP](#)

Cypress Developer Community

[Forums](#) | [WICED IOT Forums](#) | [Projects](#) | [Video](#) | [Blogs](#) | [Training](#) | [Components](#)

Technical Support

cypress.com/support



© Cypress Semiconductor Corporation, 2002–2017. This document is the property of Cypress Semiconductor Corporation and its subsidiaries, including Spansion LLC ("Cypress"). This document, including any software or firmware included or referenced in this document ("Software"), is owned by Cypress under the intellectual property laws and treaties of the United States and other countries worldwide. Cypress reserves all rights under such laws and treaties and does not, except as specifically stated in this paragraph, grant any license under its patents, copyrights, trademarks, or other intellectual property rights. If the Software is not accompanied by a license agreement and you do not otherwise have a written agreement with Cypress governing the use of the Software, then Cypress hereby grants you a personal, non-exclusive, nontransferable license (without the right to sublicense) (1) under its copyright rights in the Software (a) for Software provided in source code form, to modify and reproduce the Software solely for use with Cypress hardware products, only internally within your organization, and (b) to distribute the Software in binary code form externally to end users (either directly or indirectly through resellers and distributors), solely for use on Cypress hardware product units, and (2) under those claims of Cypress's patents that are infringed by the Software (as provided by Cypress, unmodified) to make, use, distribute, and import the Software solely for use with Cypress hardware products. Any other use, reproduction, modification, translation, or compilation of the Software is prohibited.

TO THE EXTENT PERMITTED BY APPLICABLE LAW, CYPRESS MAKES NO WARRANTY OF ANY KIND, EXPRESS OR IMPLIED, WITH REGARD TO THIS DOCUMENT OR ANY SOFTWARE OR ACCOMPANYING HARDWARE, INCLUDING, BUT NOT LIMITED TO, THE IMPLIED WARRANTIES OF MERCHANTABILITY AND FITNESS FOR A PARTICULAR PURPOSE. To the extent permitted by applicable law, Cypress reserves the right to make changes to this document without further notice. Cypress does not assume any liability arising out of the application or use of any product or circuit described in this document. Any information provided in this document, including any sample design information or programming code, is provided only for reference purposes. It is the responsibility of the user of this document to properly design, program, and test the functionality and safety of any application made of this information and any resulting product. Cypress products are not designed, intended, or authorized for use as critical components in systems designed or intended for the operation of weapons, weapons systems, nuclear installations, life-support devices or systems, other medical devices or systems (including resuscitation equipment and surgical implants), pollution control or hazardous substances management, or other uses where the failure of the device or system could cause personal injury, death, or property damage ("Unintended Uses"). A critical component is any component of a device or system whose failure to perform can be reasonably expected to cause the failure of the device or system, or to affect its safety or effectiveness. Cypress is not liable, in whole or in part, and you shall and hereby do release Cypress from any claim, damage, or other liability arising from or related to all Unintended Uses of Cypress products. You shall indemnify and hold Cypress harmless from and against all claims, costs, damages, and other liabilities, including claims for personal injury or death, arising from or related to any Unintended Uses of Cypress products.

Cypress, the Cypress logo, Spansion, the Spansion logo, and combinations thereof, WICED, PSoC, CapSense, EZ-USB, F-RAM, and Traveo are trademarks or registered trademarks of Cypress in the United States and other countries. For a more complete list of Cypress trademarks, visit cypress.com. Other names and brands may be claimed as property of their respective owners.

Looking for pricing, stock, or lifecycle information?

Click below to explore more details on WIN SOURCE:

-  [View CY2CC910OXIT on WIN SOURCE](#)
-  [Cypress Semiconductor Corp Information](#)

Optimize Your Supply Chain with WIN SOURCE Solutions

-  Global Sourcing Solution
-  Obsolete Management
-  Cost Control Management
-  Shortage Management
-  Alternative Solution
-  Excess Inventory Management