



THE DATASHEET OF AK8158A





AK8158A

Multiclock Generator with VCXO

1. General Description

The AK8158A is a member of AKM's low power multi clock generator family designed for a feature rich DTV or STB, requiring a range of system clocks with high performance. The AK8158A generates different frequency clocks from a 27MHz crystal oscillator and provides them to up to four outputs configured by pin-setting. The on-chip VCXO accepts a voltage control input to allow the output clocks to vary by ± 110 ppm for synchronizing to the external clock system. Both circuitries of VCXO and PLL in AK8158A are derived from AKM's long-term-experienced clock device technology, and enable clock output to perform low jitter and to operate with very low current consumption. The AK8158A is available in a 20-pin QFN package.

2. Features

- 27MHz Crystal Input
- Four Frequency-Selectable Clock Outputs
- One 27MHz-Reference Output
- Selectable Clock out Frequencies:
 - 74.1758, 74.250MHz
 - 25.000MHz
 - 4.9152, 12.000, 24.000, 24.576MHz
 - 33.333MHz
- Built-in VCXO
 - Pull Range: ± 110 ppm (Min.)
- Low Jitter Performance
 - Period Jitter:
30psec typ. (1σ) at CLK1-4
 - Long Term Jitter:
150psec typ. (1σ) 74.1758MHz
30psec typ. (1σ) at REFOUT
- Low Current Consumption:
16.5mA typ. at 3.3V
- Supply Voltage:
2.85 – 3.6V
- Operating Temperature Range:
-20 to +85°C
- Package:
20-pin QFN (Lead free)
- Application:
 - Digital TV Sets
 - Personal Video Recorders
 - Set Top Boxes
 - Multi Media Receivers
 - Closed-Circuit Television

3. Table of Contents

1. General Description.....	1
2. Features	1
3. Table of Contents	2
4. Block Diagram and Functions	3
5. Pin Configurations and Functions	4
6. Absolute Maximum Ratings.....	5
7. Recommended Operating Conditions	5
8. Electrical Characteristics.....	6
9. Functional Descriptions	8
10. Recommended External Circuits.....	9
11. Package.....	10
12. Important Notice.....	12

4. Block Diagram and Functions

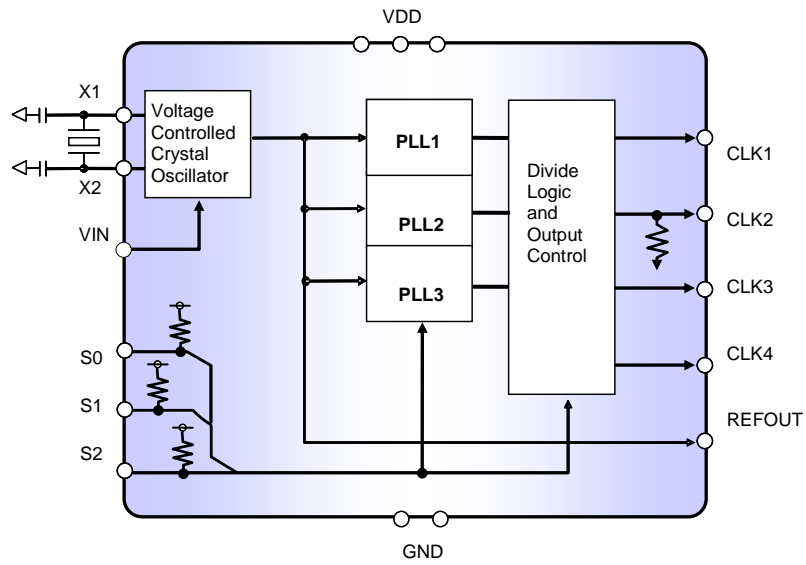

Figure 1. AK8158A Multi Clock Generator

5. Pin Configurations and Functions

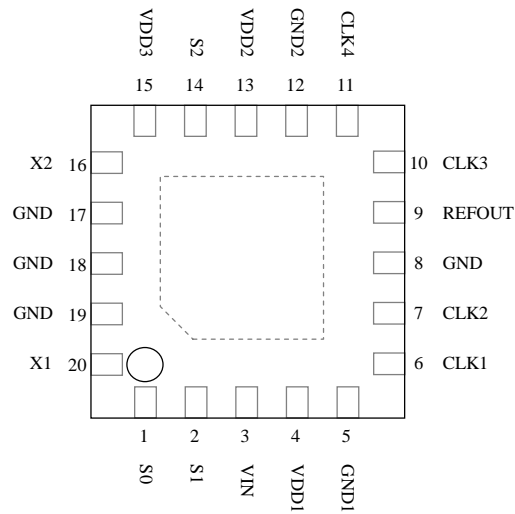

Figure 2. AK8158A Package: 20-Pin QFN(Top View)

Pin No.	Pin Name	Pin Type	Description
1	S0	IN	Clock Out Frequency Select 0, See Table 1 for the selection (2)
2	S1	IN	Clock Out Frequency select 1, See Table 1 for the selection (2)
3	VIN	IN	VCXO Control Voltage Input
4	VDD1	--	Power Supply 1
5	GND1	--	Ground 1
6	CLK1	OUT	Clock output 1, See Table 1 for its selectable frequency
7	CLK2	OUT	Clock output 2, See Table 1 for its selectable frequency (3)
8	GND	--	Connect to Ground
9	REFOUT	OUT	Reference Clock Output of VCXO based on 27.000MHz Crystal
10	CLK3	OUT	Clock output 3, See Table 1 for its selectable frequency
11	CLK4	OUT	Clock output 4, See Table 1 for its selectable frequency
12	GND2	--	Ground 2
13	VDD2	--	Power Supply 2
14	S2	IN	Clock Out Frequency select 1, See Table 1 for the selection (2)
15	VDD3	--	Power Supply 3
16	X2	XI	Crystal connection, Connect to 27.000MHz crystal Or external clock input (minimum 1Vpp input).
17	GND	--	Connect to Ground
18	GND	--	Connect to Ground
19	GND	--	Connect to Ground
20	X1	XO	Crystal connection, Connect to 27.000MHz crystal Please open when an external clock input is used

Note:

- (1) The heatsink pad on the bottom surface of the package can be open or be connected to GND.
- (2) Internal pull up 360k Ω
- (3) Internal pull down 510k Ω

6. Absolute Maximum Ratings

Over operating free-air temperature range unless otherwise noted ⁽¹⁾

Items	Symbol	Ratings	Unit
Supply voltage	VDD	-0.3 to 4.6	V
Input voltage	V _{in}	VSS-0.3 to VDD+0.3	V
Input current (any pins except supplies)	I _{IN}	±10	mA
Storage temperature	T _{stg}	-55 to 130	°C

Note

- (1) Stress beyond those listed under “Absolute Maximum Ratings” may cause permanent damage to the device. These are stress ratings only. Functional operation of the device at these or any other conditions beyond those indicated under “Recommended Operating Conditions” is not implied. Exposure to absolute-maximum-rating conditions for extended periods may affect device reliability. Electrical parameters are guaranteed only over the recommended operating temperature range.



ESD Sensitive Device

This device is manufactured on a CMOS process, therefore, generically susceptible to damage by excessive static voltage.

Failure to observe proper handling and installation procedures can cause damage. AKM recommends that this device is handled with appropriate precautions.

7. Recommended Operating Conditions

Parameter	Symbol	Conditions	Min	Typ	Max	Unit
Operating temperature	T _a		-20		85	°C
Supply voltage ⁽¹⁾	VDD		2.85	3.3	3.6	V
Output Load Capacitance	C _{p1}	Pin: CLK1-4			15	pF
	C _{p2}	Pin: REFOUT			25	pF

Note:

- (1) Power to VDD1, VDD2 and VDD3 requires to be supplied from a single source. A decoupling capacitor of 0.1μF for power supply line should be installed close to each VDD pin.

8. Electrical Characteristics

DC Characteristics

All specifications at VDD: over 2.85 to 3.6V, Ta: -20 to +85°C, 27MHz Crystal, unless otherwise noted

Parameter	Symbol	Conditions	MIN	TYP	MAX	Unit
High Level Input Voltage	V_{IH}	Pin: S0, S1, S2	0.7VDD			V
Low Level Input Voltage	V_{IL}	Pin: S0, S1, S2			0.3VDD	V
Input Current 1	I_{L1}	Pin: S0, S1, S2	-20		+1.5	μ A
Input Current 2	I_{L2}	Pin: VIN	-3		+3	μ A
High Level Output Voltage	V_{OH}	Pin: CLK1-4, REFOUT $I_{OH} = -4\text{mA}$ ⁽¹⁾	0.8VDD			V
Low level Output Voltage	V_{OL}	Pin: CLK1-4, REFOUT $I_{OL} = +4\text{mA}$ ⁽¹⁾			0.2VDD	V
Current Consumption	I_{DD}	No load Clock out selection by note ⁽²⁾ Ta = 25°C		18.0		mA
		No load Clock out selection by note ⁽³⁾ Ta = 25°C		16.5		mA

Note:

(1) Polarity(-): Outgoing current from device

Polarity(+): Incoming current to device

(2) Pin setting for output clock selection: [S2:S0] = "HLL"

(3) Pin setting for output clock selection: [S2:S0] = "HLH"

AC Characteristics

All specifications at VDD: over 2.85 to 3.6V, Ta: over -20 to +85°C, 27MHz Crystal, unless otherwise noted

Parameter	Symbol	Conditions	MIN	TYP	MAX	Unit
Crystal Clock Frequency				27.0000		MHz
VCXO Pullable Range ⁽³⁾		VIN at over 0 to VDD V	±110			ppm
VCXO Gain	G _{VCXO}	VIN range at 1.5V±1.0V		150		ppm/V
Period Jitter ⁽⁴⁾		CLK1-4		30		ps
Long Term Jitter ⁽⁴⁾		CLK1 at 74.1758MHz 1000 cycle delay		150		ns
		REFOUT at 27.000MHz 1000 cycle delay		30		ps
Output Clock Duty Cycle		Pin: CLK1-4 ⁽¹⁾	45	50	55	%
		Pin: REFOUT ⁽²⁾	40	50	60	%
Output Clock Rise Time	t _{rise}	Pin: CLK1-4 ⁽¹⁾		1.5	4	ns
		Pin: REFOUT ⁽²⁾		2.5	4	ns
Output Clock Fall Time	t _{fall}	Pin: CLK1-4 ⁽¹⁾		1.5	4	ns
		Pin: REFOUT ⁽²⁾		2.5	4	ns
Power-up Time		Pin: CLK1-4 ⁽¹⁾		1	2	ms
Output Transition Time ⁽⁵⁾		Pin: CLK1 at 74.25 or 74.175MHz		90	140	μs

Note:

- (1) Measured with load capacitance of 15pF
- (2) Measured with load capacitance of 25pF
- (3) Pullable range depends on crystal characteristics, on-chip load capacitance, and stray capacity of PCB. Min. ±110ppm is applied to AKM's authorized test condition.
- (4) 1σ in 10000 sampling or more
- (5) Time to settle output into ±20ppm of specified frequency

9. Functional Descriptions

Output clock frequency selection

The AK8158A generates a range of low-jitter and hi-accuracy clock frequencies with three built-in PLLs and provides up to four assigned outputs. A frequency selection at assigned output pin is configured by pin-setting of S0 (Pin 1), S1 (Pin 2), and S2 (Pin 14).

The selectable frequency is shown in Table 1..

Table 1. Clock output Frequency

Selection Pin			Clock Output Frequency (MHz)			
S2 (Pin 14)	S1 (Pin 2)	S0 (Pin 1)	CLK1 (Pin 6)	CLK2 (Pin 7)	CLK3 (Pin 10)	CLK4 (Pin 11)
L	L	L	74.250	25.000	24.000	33.333
L	L	H	74.250	25.000	12.000	33.333
L	H	L	74.1758	25.000	24.000	33.333
L	H	H	74.1758	25.000	12.000	33.333
H	L	L	74.250	25.000	24.576	33.333
H	L	H	74.250	OFF	24.000	33.333
H	H	L	74.1758	25.000	24.576	33.333
H	H	H	74.1758	25.000	4.9152	33.333

Voltage Control Crystal Oscillator (VCXO)

The AK8158A has a voltage control crystal oscillator (VCXO), featuring fine frequency tuning for 27MHz of primary clock frequency by external DC voltage control. This tuning enables output clock frequency to synchronize the external clock system. VIN (Pin 3) accepts DC voltage control from a processor or a system controller, and pulls the primary frequency of crystal to higher or lower. This pulling range is determined by crystal characteristic, on-chip load capacitor, and stray capacitance of PCB. The AK8158A is designed to range ± 110 ppm of primary frequency in AKM's authorized condition.

10. Recommended External Circuits

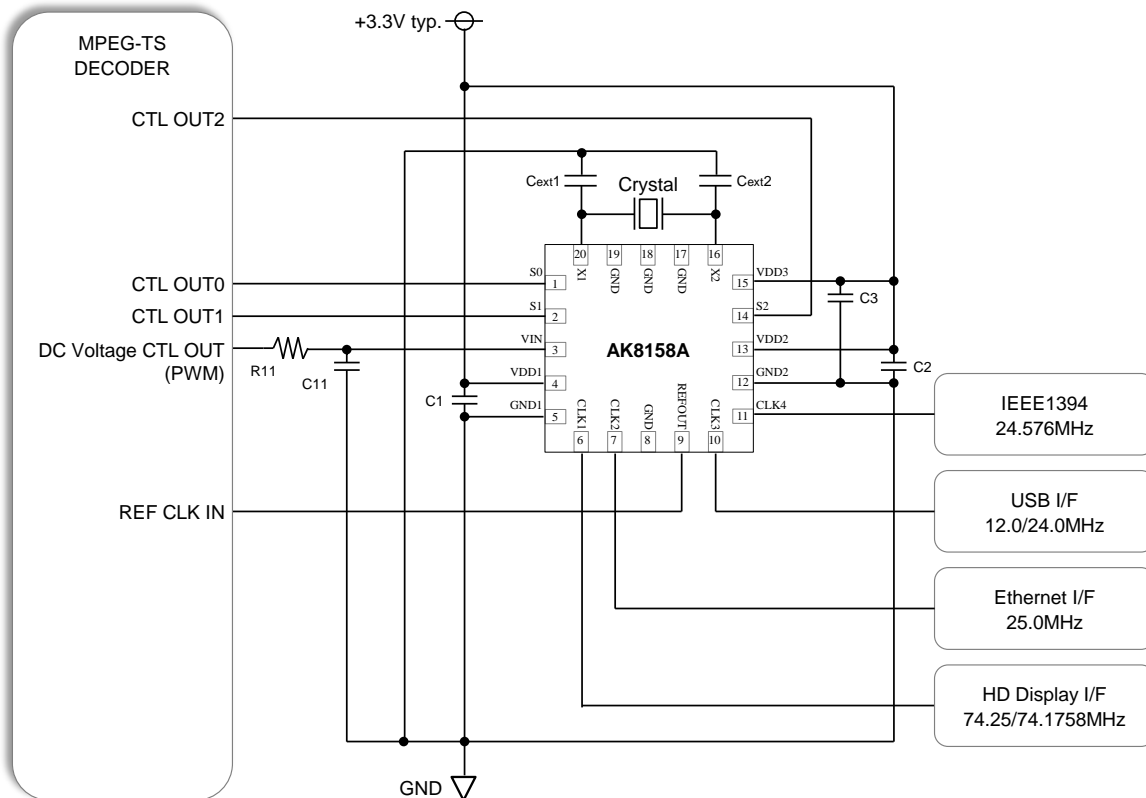

Figure 3: Typical Connection Diagram

C1, C2, C3: 0.1 μ F

Cext1, Cext2: Depends on crystal characteristics. Refer the specification of the crystal.

R11, C11: In case of interface by PWM. For right configuration, refer the specification of the applied processor.

PCB Layout Consideration

The AK8158A is a high-accuracy and low-jitter multi clock generator. For proper performances specified in this datasheet, careful PCB layout should be taken. The followings are layout guidelines based on the typical connection diagram shown in Figure ..

Power supply line – AK8158A has three power supply pins (VDD1-3) which deliver power to internal circuitry segments. A 0.1 μ F decoupling capacitor should be placed as close to each VDD pin as possible.

Ground pin connection – AK8158A has two ground pins (GND1-2). These pin require connecting to plane ground which will eliminate any common impedance with other critical switching signal return. 0.1 μ F decoupling capacitors placed at VDD1, VDD2, and VDD3 should be grounded at close to the GND1 pin, the GND2 pin, and the GND2, respectively.

Crystal connection – Proper oscillation performance and pullable range are susceptible to stray or parasitic capacitors around crystal. The wiring traces to a crystal from X1 (Pin 20) and X2 (Pin 16) have equal lengths with no via and as short in length as possible. These traces should be also located away from any traces with switching signal.

11. Package

Outline Dimensions

20pin QFN (Unit: mm)

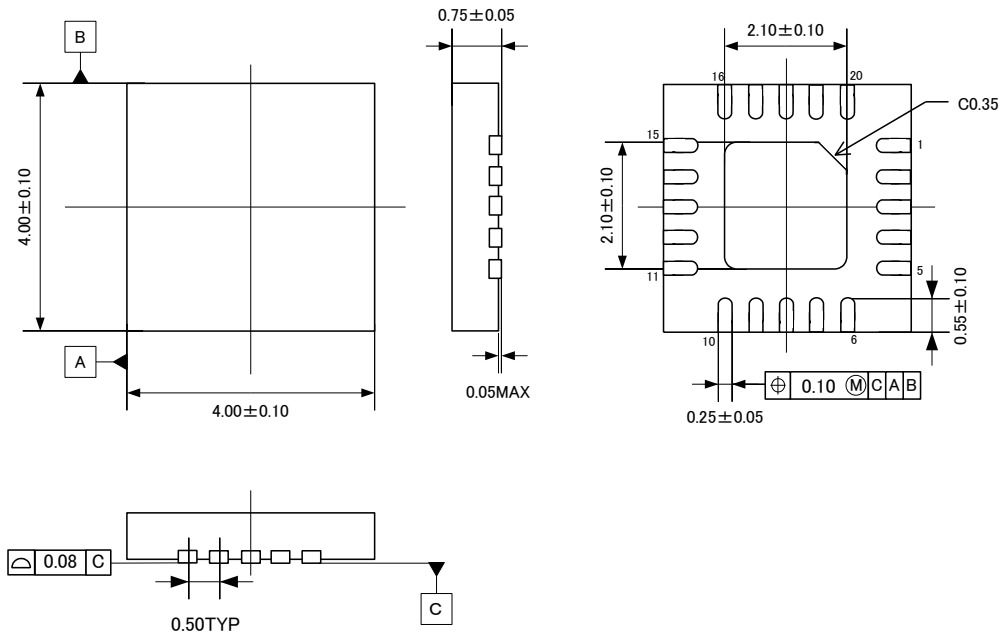

Marking

- a: #1 Pin Index
- b: Part number
- c: Date code (4 digits: YWWL, Year/Weak/Lot No.)

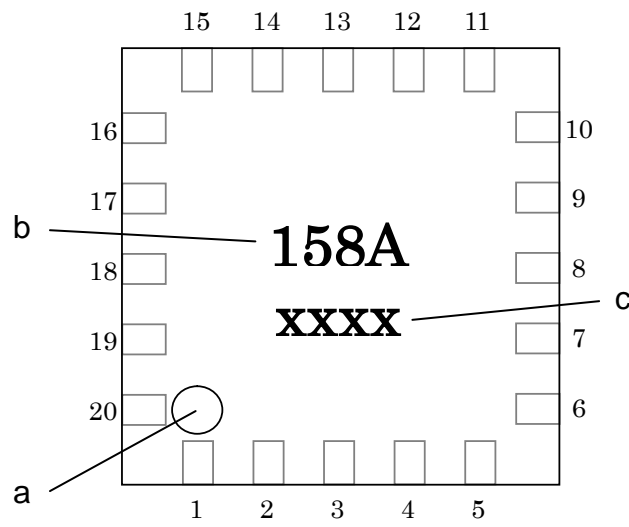



12. Important Notice**IMPORTANT NOTICE**





0. Asahi Kasei Microdevices Corporation (“AKM”) reserves the right to make changes to the information contained in this document without notice. When you consider any use or application of AKM product stipulated in this document (“Product”), please make inquiries the sales office of AKM or authorized distributors as to current status of the Products.
1. All information included in this document are provided only to illustrate the operation and application examples of AKM Products. AKM neither makes warranties or representations with respect to the accuracy or completeness of the information contained in this document nor grants any license to any intellectual property rights or any other rights of AKM or any third party with respect to the information in this document. You are fully responsible for use of such information contained in this document in your product design or applications. **AKM ASSUMES NO LIABILITY FOR ANY LOSSES INCURRED BY YOU OR THIRD PARTIES ARISING FROM THE USE OF SUCH INFORMATION IN YOUR PRODUCT DESIGN OR APPLICATIONS.**
2. The Product is neither intended nor warranted for use in equipment or systems that require extraordinarily high levels of quality and/or reliability and/or a malfunction or failure of which may cause loss of human life, bodily injury, serious property damage or serious public impact, including but not limited to, equipment used in nuclear facilities, equipment used in the aerospace industry, medical equipment, equipment used for automobiles, trains, ships and other transportation, traffic signaling equipment, equipment used to control combustions or explosions, safety devices, elevators and escalators, devices related to electric power, and equipment used in finance-related fields. Do not use Product for the above use unless specifically agreed by AKM in writing.
3. Though AKM works continually to improve the Product’s quality and reliability, you are responsible for complying with safety standards and for providing adequate designs and safeguards for your hardware, software and systems which minimize risk and avoid situations in which a malfunction or failure of the Product could cause loss of human life, bodily injury or damage to property, including data loss or corruption.
4. Do not use or otherwise make available the Product or related technology or any information contained in this document for any military purposes, including without limitation, for the design, development, use, stockpiling or manufacturing of nuclear, chemical, or biological weapons or missile technology products (mass destruction weapons). When exporting the Products or related technology or any information contained in this document, you should comply with the applicable export control laws and regulations and follow the procedures required by such laws and regulations. The Products and related technology may not be used for or incorporated into any products or systems whose manufacture, use, or sale is prohibited under any applicable domestic or foreign laws or regulations.
5. Please contact AKM sales representative for details as to environmental matters such as the RoHS compatibility of the Product. Please use the Product in compliance with all applicable laws and regulations that regulate the inclusion or use of controlled substances, including without limitation, the EU RoHS Directive. AKM assumes no liability for damages or losses occurring as a result of noncompliance with applicable laws and regulations.
6. Resale of the Product with provisions different from the statement and/or technical features set forth in this document shall immediately void any warranty granted by AKM for the Product and shall not create or extend in any manner whatsoever, any liability of AKM.
7. This document may not be reproduced or duplicated, in any form, in whole or in part, without prior written consent of AKM.

Looking for pricing, stock, or lifecycle information?

Click below to explore more details on WIN SOURCE:

-  [View AK8158A on WIN SOURCE](#)
-  [Asahi Kasei Microsystems Information](#)

Optimize Your Supply Chain with WIN SOURCE Solutions

-  Global Sourcing Solution
-  Obsolete Management
-  Cost Control Management
-  Shortage Management
-  Alternative Solution
-  Excess Inventory Management