



**THE DATASHEET OF  
M27C512-90B1**



## 512 Kbit (64K x8) UV EPROM and OTP EPROM

### Features

- 5V ± 10% supply voltage in read operation
- Access time: 45 ns
- Low power “CMOS” consumption:
  - Active current 30 mA
  - Standby current 100 µA
- Programming voltage: 12.75 V ± 0.25 V
- Programming time around 6 s.
- Electronic Signature
  - Manufacturer code: 20h
  - Device code: 3Dh
- Packages
  - ECOPACK® versions



**Table 1. Device summary**

Package	45 ns	70 ns	90 ns	100 ns	120 ns	150 ns
PDIP28			M27C512-90B6			
PLCC32		M27C512-70C6	M27C512-90C1	M27C512-10C6	M27C512-12C3	
FDIP28W	M27C512-45XF1	M27C512-70XF1	M27C512-90F1 M27C512-90F6	M27C512-10F1	M27C512-12F1 M27C512-12F3	M27C512-15F1 M27C512-15F6

# Contents

<b>1</b>	<b>Description</b> .....	<b>3</b>
<b>2</b>	<b>Device operation</b> .....	<b>5</b>
2.1	Read mode .....	5
2.2	Standby mode .....	5
2.3	Two line output control .....	6
2.4	System considerations .....	6
2.5	Programming .....	7
2.6	PRESTO IIB programming algorithm .....	7
2.7	Program Inhibit .....	8
2.8	Program Verify .....	8
2.9	Electronic Signature .....	8
<b>3</b>	<b>Erase operation (applies for UV EPROM)</b> .....	<b>9</b>
<b>4</b>	<b>Maximum rating</b> .....	<b>10</b>
<b>5</b>	<b>DC and AC parameters</b> .....	<b>11</b>
<b>6</b>	<b>Package mechanical</b> .....	<b>17</b>
<b>7</b>	<b>Part numbering</b> .....	<b>20</b>
<b>8</b>	<b>Revision history</b> .....	<b>21</b>

# 1 Description

The M27C512 is a 512 Kbit EPROM offered in the two ranges UV (ultra violet erase) and OTP (one time programmable). It is ideally suited for applications where fast turn-around and pattern experimentation are important requirements and is organized as 65536 by 8 bits.

The FDIP28W (window ceramic frit-seal package) has transparent lid which allows the user to expose the chip to ultraviolet light to erase the bit pattern. A new pattern can then be written to the device by following the programming procedure.

For applications where the content is programmed only one time and erasure is not required, the M27C512 is offered in FDIP28W, PDIP28, and PLCC32 packages. In order to meet environmental requirements, ST offers the M27C512 in ECOPACK® packages. ECOPACK packages are Lead-free. The category of second Level Interconnect is marked on the package and on the inner box label, in compliance with JEDEC Standard JESD97. The maximum ratings related to soldering conditions are also marked on the inner box label. ECOPACK is an ST trademark. ECOPACK specifications are available at: [www.st.com](http://www.st.com).

**Figure 1. Logic diagram**

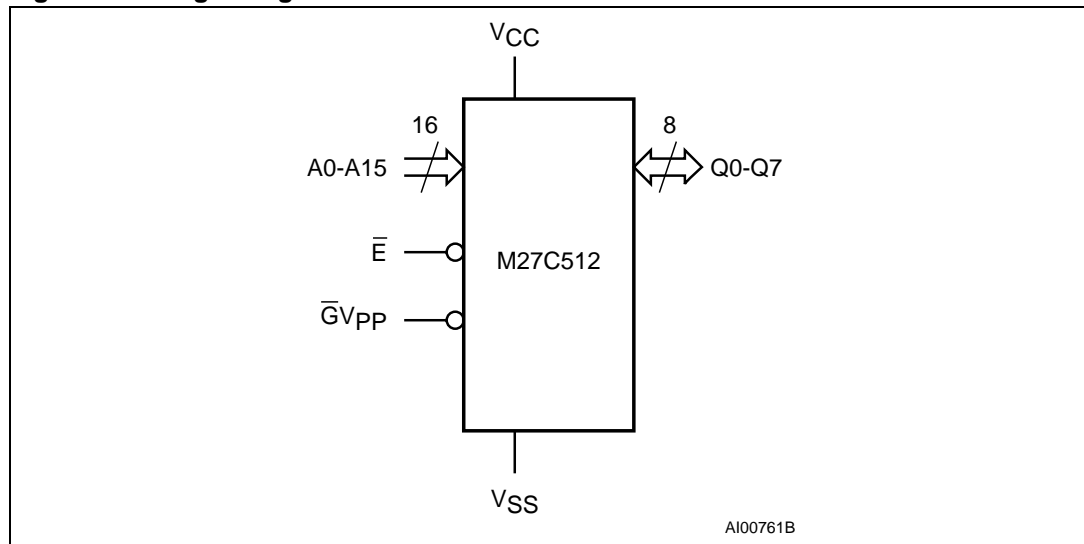

**Table 2. Signal names**

Name	Description	Direction
A0-A15	Address Inputs	Inputs
Q0-Q7	Data outputs	Outputs
$\bar{E}$	Chip Enable	Input
$\bar{G}V_{PP}$	Output Enable / Program Supply	Input
$V_{CC}$	Supply Voltage	Supply
$V_{SS}$	Ground	Supply
NC	Not Connected Internally	-
DU	Don't Use	-

Figure 2. DIP connections



Figure 3. LCC connections



## 2 Device operation

The modes of operations of the M27C512 are listed in the Operating Modes table. A single power supply is required in the read mode. All inputs are TTL levels except for  $\overline{G}V_{PP}$  and 12V on A9 for Electronic Signature.

### 2.1 Read mode

The M27C512 has two control functions, both of which must be logically active in order to obtain data at the outputs. Chip Enable ( $\overline{E}$ ) is the power control and should be used for device selection. Output Enable ( $\overline{G}$ ) is the output control and should be used to gate data to the output pins, independent of device selection. Assuming that the addresses are stable, the address access time ( $t_{AVQV}$ ) is equal to the delay from  $\overline{E}$  to output ( $t_{ELQV}$ ). Data is available at the output after a delay of  $t_{GLQV}$  from the falling edge of  $\overline{G}$ , assuming that  $\overline{E}$  has been low and the addresses have been stable for at least  $t_{AVQV} - t_{GLQV}$ .

### 2.2 Standby mode

The M27C512 has a standby mode which reduces the active current from 30mA to 100 $\mu$ A. The M27C512 is placed in the standby mode by applying a CMOS high signal to the  $\overline{E}$  input. When in the standby mode, the outputs are in a high impedance state, independent of the  $\overline{G}V_{PP}$  input.

**Table 3. Operating modes<sup>(1)</sup>**

Mode	$\overline{E}$	$\overline{G}V_{PP}$	A9	Q7-Q0
Read	$V_{IL}$	$V_{IL}$	X	Data Out
Output Disable	$V_{IL}$	$V_{IH}$	X	Hi-Z
Program	$V_{IL}$ Pulse	$V_{PP}$	X	Data In
Program Inhibit	$V_{IH}$	$V_{PP}$	X	Hi-Z
Standby	$V_{IH}$	X	X	Hi-Z
Electronic Signature	$V_{IL}$	$V_{IL}$	$V_{ID}$	Codes

1. X =  $V_{IH}$  or  $V_{IL}$ ,  $V_{ID} = 12V \pm 0.5V$ .

**Table 4. Electronic Signature**

Identifier	A0	Q7	Q6	Q5	Q4	Q3	Q2	Q1	Q0	Hex Data
Manufacturer's Code	$V_{IL}$	0	0	1	0	0	0	0	0	20h
Device Code	$V_{IH}$	0	0	1	1	1	1	0	1	3Dh

## 2.3 Two line output control

Because EPROMs are usually used in larger memory arrays, the product features a 2 line control function which accommodates the use of multiple memory connection. The two line control function allows:

- The lowest possible memory power dissipation,
- Complete assurance that output bus contention will not occur.

For the most efficient use of these two control lines,  $\overline{E}$  should be decoded and used as the primary device selecting function, while  $\overline{G}$  should be made a common connection to all devices in the array and connected to the  $\overline{READ}$  line from the system control bus. This ensures that all deselected memory devices are in their low power standby mode and that the output pins are only active when data is required from a particular memory device.

## 2.4 System considerations

The power switching characteristics of Advanced CMOS EPROMs require careful decoupling of the devices. The supply current,  $I_{CC}$ , has three segments that are of interest to the system designer: the standby current level, the active current level, and transient current peaks that are produced by the falling and rising edges of  $\overline{E}$ . The magnitude of the transient current peaks is dependent on the capacitive and inductive loading of the device at the output. The associated transient voltage peaks can be suppressed by complying with the two line output control and by properly selected decoupling capacitors. It is recommended that a 0.1 $\mu$ F ceramic capacitor be used on every device between  $V_{CC}$  and  $V_{SS}$ . This should be a high frequency capacitor of low inherent inductance and should be placed as close to the device as possible. In addition, a 4.7 $\mu$ F bulk electrolytic capacitor should be used between  $V_{CC}$  and  $V_{SS}$  for every eight devices. The bulk capacitor should be located near the power supply connection point. The purpose of the bulk capacitor is to overcome the voltage drop caused by the inductive effects of PCB traces.

Figure 4. Programming flowchart

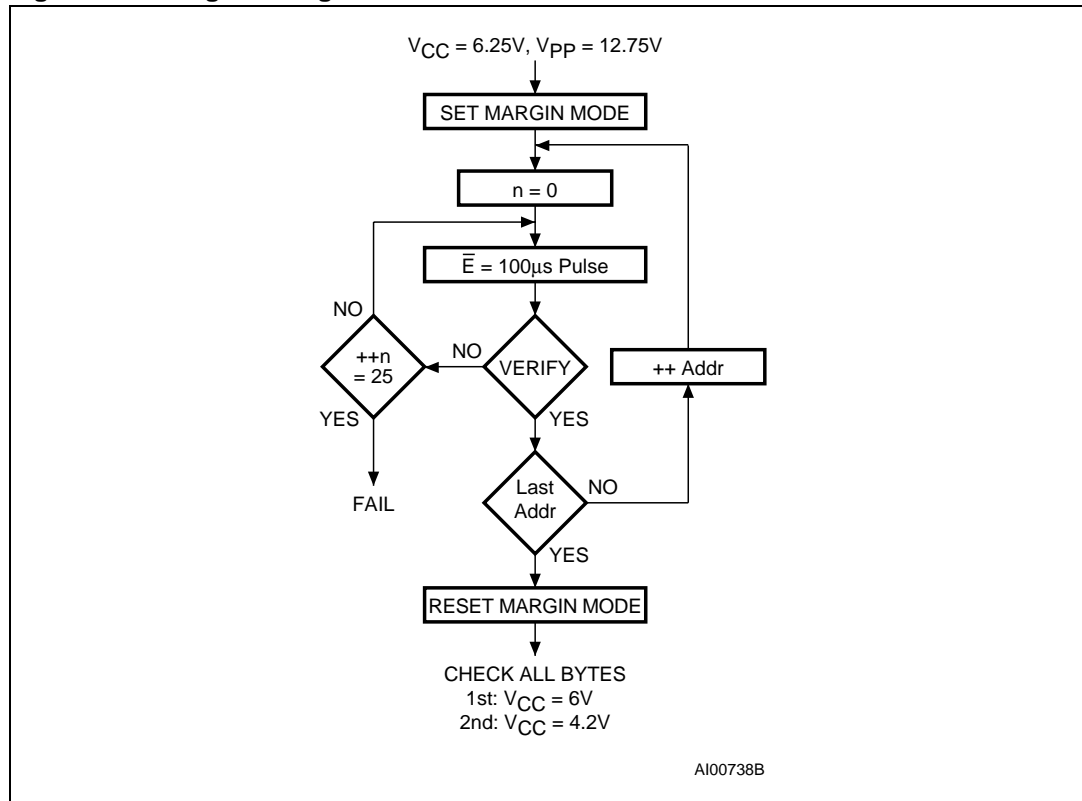

## 2.5 Programming

When delivered (and after each erasure for UV EPROM), all bits of the M27C512 are in the '1' state. Data is introduced by selectively programming '0's into the desired bit locations. Although only '0's will be programmed, both '1's and '0's can be present in the data word. The only way to change a '0' to a '1' is by die exposure to ultraviolet light (UV EPROM). The M27C512 is in the programming mode when  $V_{PP}$  input is at 12.75V and  $\bar{E}$  is pulsed to  $V_{IL}$ . The data to be programmed is applied to 8 bits in parallel to the data output pins. The levels required for the address and data inputs are TTL.  $V_{CC}$  is specified to be  $6.25V \pm 0.25V$ . The M27C512 can use PRESTO IIB Programming Algorithm that drastically reduces the programming time (typically less than 6 seconds). Nevertheless to achieve compatibility with all programming equipments, PRESTO Programming Algorithm can be used as well.

## 2.6 PRESTO IIB programming algorithm

PRESTO IIB Programming Algorithm allows the whole array to be programmed with a guaranteed margin, in a typical time of 6.5 seconds. This can be achieved with STMicroelectronics M27C512 due to several design innovations described in the M27C512 datasheet to improve programming efficiency and to provide adequate margin for reliability. Before starting the programming the internal MARGIN MODE circuit is set in order to guarantee that each cell is programmed with enough margin. Then a sequence of 100µs program pulses are applied to each byte until a correct verify occurs. No overprogram pulses are applied since the verify in MARGIN MODE provides the necessary margin.

## 2.7 Program Inhibit

Programming of multiple M27C512s in parallel with different data is also easily accomplished. Except for  $\bar{E}$ , all like inputs including  $\bar{G}V_{PP}$  of the parallel M27C512 may be common. A TTL low level pulse applied to a M27C512's  $\bar{E}$  input, with  $V_{PP}$  at 12.75V, will program that M27C512. A high level  $\bar{E}$  input inhibits the other M27C512s from being programmed.

## 2.8 Program Verify

A verify (read) should be performed on the programmed bits to determine that they were correctly programmed. The verify is accomplished with  $\bar{G}$  at  $V_{IL}$ . Data should be verified with  $t_{ELQV}$  after the falling edge of  $\bar{E}$ .

## 2.9 Electronic Signature

The Electronic Signature (ES) mode allows the reading out of a binary code from an EPROM that will identify its manufacturer and type. This mode is intended for use by programming equipment to automatically match the device to be programmed with its corresponding programming algorithm. The ES mode is functional in the  $25^{\circ}\text{C} \pm 5^{\circ}\text{C}$  ambient temperature range that is required when programming the M27C512. To activate the ES mode, the programming equipment must force 11.5V to 12.5V on address line A9 of the M27C512. Two identifier bytes may then be sequenced from the device outputs by toggling address line A0 from  $V_{IL}$  to  $V_{IH}$ . All other address lines must be held at  $V_{IL}$  during Electronic Signature mode. Byte 0 ( $A0 = V_{IL}$ ) represents the manufacturer code and byte 1 ( $A0 = V_{IH}$ ) the device identifier code. For the STMicroelectronics M27C512, these two identifier bytes are given in <Blue>Table 4. and can be read-out on outputs Q7 to Q0.

### 3 Erasure operation (applies for UV EPROM)

The erasure characteristics of the M27C512 is such that erasure begins when the cells are exposed to light with wavelengths shorter than approximately 4000 Å. It should be noted that sunlight and some type of fluorescent lamps have wavelengths in the 3000-4000 Å range.

Research shows that constant exposure to room level fluorescent lighting could erase a typical M27C512 in about 3 years, while it would take approximately 1 week to cause erasure when exposed to direct sunlight. If the M27C512 is to be exposed to these types of lighting conditions for extended periods of time, it is suggested that opaque labels be put over the M27C512 window to prevent unintentional erasure. The recommended erasure procedure for the M27C512 is exposure to short wave ultraviolet light which has wavelength 2537 Å. The integrated dose (i.e. UV intensity x exposure time) for erasure should be a minimum of 15 W-sec/cm<sup>2</sup>. The erasure time with this dosage is approximately 15 to 20 minutes using an ultraviolet lamp with 12000 µW/cm<sup>2</sup> power rating. The M27C512 should be placed within 2.5 cm (1 inch) of the lamp tubes during the erasure. Some lamps have a filter on their tubes which should be removed before erasure.

## 4 Maximum rating

Stressing the device outside the ratings listed in <Blue>Table 5. may cause permanent damage to the device. These are stress ratings only, and operation of the device at these, or any other conditions outside those indicated in the Operating sections of this specification, is not implied. Exposure to Absolute Maximum Rating conditions for extended periods may affect device reliability. Refer also to the STMicroelectronics SURE Program and other relevant quality documents.

**Table 5. Absolute maximum ratings**

Symbol	Parameter	Value	Unit
$T_A$	Ambient Operating Temperature <sup>(1)</sup>	-40 to 125	°C
$T_{BIAS}$	Temperature Under Bias	-50 to 125	°C
$T_{STG}$	Storage Temperature	-65 to 150	°C
$T_{LEAD}$	Lead Temperature during Soldering	(note 1)	°C
$V_{IO}^{(2)}$	Input or Output Voltage (except A9)	-2 to 7	V
$V_{CC}$	Supply Voltage	-2 to 7	V
$V_{A9}^{(2)}$	A9 Voltage	-2 to 13.5	V
$V_{PP}$	Program Supply Voltage	-2 to 14	V

1. Depends on range.
2. Minimum DC voltage on Input or Output is -0.5V with possible undershoot to -2.0V for a period less than 20ns. Maximum DC voltage on Output is  $V_{CC} + 0.5V$  with possible overshoot to  $V_{CC} + 2V$  for a period less than 20ns.

## 5 DC and AC parameters

This section summarizes the operating and measurement conditions, and the DC and AC characteristics of the device. The parameters in the DC and AC Characteristic tables that follow are derived from tests performed under the Measurement Conditions summarized in the relevant tables. Designers should check that the operating conditions in their circuit match the measurement conditions when relying on the quoted parameters.

**Table 6. AC measurement conditions**

	High Speed	Standard
Input Rise and Fall Times	≤ 10ns	≤ 20ns
Input Pulse Voltages	0 to 3V	0.4V to 2.4V
Input and Output Timing Ref. Voltages	1.5V	0.8V and 2V

**Figure 5. Testing input/output waveform**

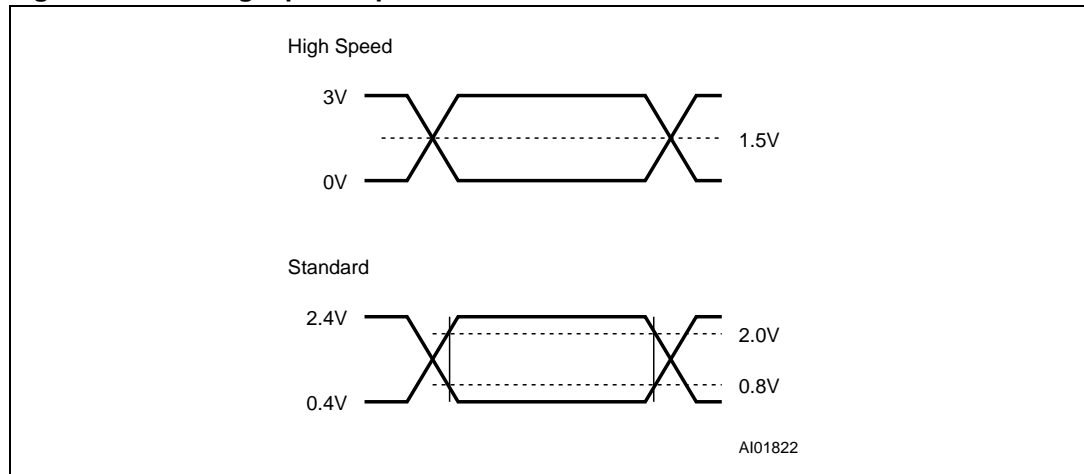

**Figure 6. AC Testing Load Circuit**

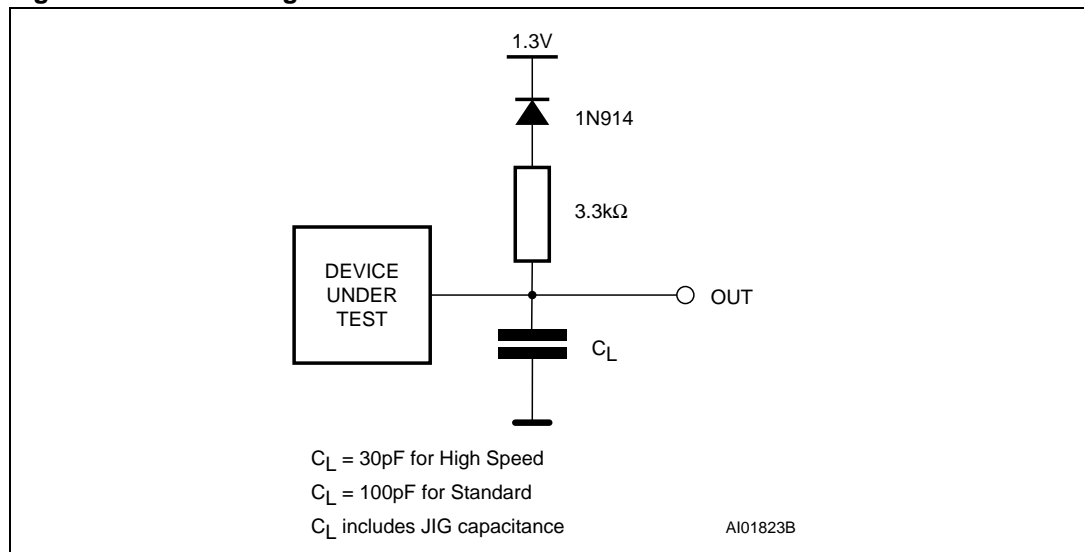

**Table 7. Capacitance**

Symbol	Parameter	Test Condition <sup>(1)(2)</sup>	Min	Max	Unit
C <sub>IN</sub>	Input Capacitance	V <sub>IN</sub> = 0V		6	pF
C <sub>OUT</sub>	Output Capacitance	V <sub>OUT</sub> = 0V		12	pF

1. T<sub>A</sub> = 25°C, f = 1MHz

2. Sampled only, not 100% tested.

**Table 8. Read mode DC characteristics**

Symbol	Parameter	Test Condition <sup>(1)</sup>	Min	Max	Unit
I <sub>LI</sub>	Input Leakage Current	0V ≤ V <sub>IN</sub> ≤ V <sub>CC</sub>		±10	μA
I <sub>LO</sub>	Output Leakage Current	0V ≤ V <sub>OUT</sub> ≤ V <sub>CC</sub>		±10	μA
I <sub>CC</sub>	Supply Current	$\bar{E} = V_{IL}, \bar{G} = V_{IL},$ I <sub>OUT</sub> = 0mA, f = 5MHz		30	mA
I <sub>CC1</sub>	Supply Current (Standby) TTL	$\bar{E} = V_{IH}$		1	mA
I <sub>CC2</sub>	Supply Current (Standby) CMOS	$\bar{E} > V_{CC} - 0.2V$		100	μA
I <sub>PP</sub>	Program Current	V <sub>PP</sub> = V <sub>CC</sub>		10	μA
V <sub>IL</sub>	Input Low Voltage		-0.3	0.8	V
V <sub>IH</sub> <sup>(2)</sup>	Input High Voltage		2	V <sub>CC</sub> + 1	V
V <sub>OL</sub>	Output Low Voltage	I <sub>OL</sub> = 2.1mA		0.4	V
V <sub>OH</sub>	Output High Voltage TTL	I <sub>OH</sub> = -1mA	3.6		V
	Output High Voltage CMOS	I <sub>OH</sub> = -100μA	V <sub>CC</sub> - 0.7V		V

1. V<sub>CC</sub> must be applied simultaneously with or before V<sub>PP</sub> and removed simultaneously or after V<sub>PP</sub>.

2. Maximum DC voltage on Output is V<sub>CC</sub> +0.5V.

Table 9. Read mode AC characteristics

Symbol	Alt	Parameter	Test Condition <sup>(1)</sup>	M27C512				Unit
				-45 <sup>(2)</sup>		-70		
				Min	Max	Min	Max	
t <sub>AVQV</sub>	t <sub>ACC</sub>	Address Valid to Output Valid	$\bar{E} = V_{IL}, \bar{G} = V_{IL}$		45		70	ns
t <sub>ELQV</sub>	t <sub>CE</sub>	Chip Enable Low to Output Valid	$\bar{G} = V_{IL}$		45		70	ns
t <sub>GLQV</sub>	t <sub>OE</sub>	Output Enable Low to Output Valid	$\bar{E} = V_{IL}$		25		35	ns
t <sub>EHQZ</sub> <sup>(3)</sup>	t <sub>DF</sub>	Chip Enable High to Output Hi-Z	$\bar{G} = V_{IL}$	0	25	0	30	ns
t <sub>GHQZ</sub> <sup>(3)</sup>	t <sub>DF</sub>	Output Enable High to Output Hi-Z	$\bar{E} = V_{IL}$	0	25	0	30	ns
t <sub>AXQX</sub>	t <sub>OH</sub>	Address Transition to Output Transition	$\bar{E} = V_{IL}, \bar{G} = V_{IL}$	0		0		ns

1. V<sub>CC</sub> must be applied simultaneously with or before V<sub>PP</sub> and removed simultaneously or after V<sub>PP</sub>.
2. Speed obtained with High Speed AC measurement conditions.
3. Sampled only, not 100% tested.

Table 10. Read mode AC characteristics

Symbol	Alt	Parameter	Test Condition <sup>(1)</sup>	M27C512								Unit
				-90		-10		-12		-15		
				Min	Max	Min	Max	Min	Max	Min	Max	
t <sub>AVQV</sub>	t <sub>ACC</sub>	Address Valid to Output Valid	$\bar{E} = V_{IL}, \bar{G} = V_{IL}$		90		100		120		150	ns
t <sub>ELQV</sub>	t <sub>CE</sub>	Chip Enable Low to Output Valid	$\bar{G} = V_{IL}$		90		100		120		150	ns
t <sub>GLQV</sub>	t <sub>OE</sub>	Output Enable Low to Output Valid	$\bar{E} = V_{IL}$		40		40		50		60	ns
t <sub>EHQZ</sub> <sup>(2)</sup>	t <sub>DF</sub>	Chip Enable High to Output Hi-Z	$\bar{G} = V_{IL}$	0	30	0	30	0	40	0	50	ns
t <sub>GHQZ</sub> <sup>(2)</sup>	t <sub>DF</sub>	Output Enable High to Output Hi-Z	$\bar{E} = V_{IL}$	0	30	0	30	0	40	0	50	ns
t <sub>AXQX</sub>	t <sub>OH</sub>	Address Transition to Output Transition	$\bar{E} = V_{IL}, \bar{G} = V_{IL}$	0		0		0		0		ns

1. V<sub>CC</sub> must be applied simultaneously with or before V<sub>PP</sub> and removed simultaneously or after V<sub>PP</sub>.
2. Sampled only, not 100% tested.

Figure 7. Read mode AC waveforms

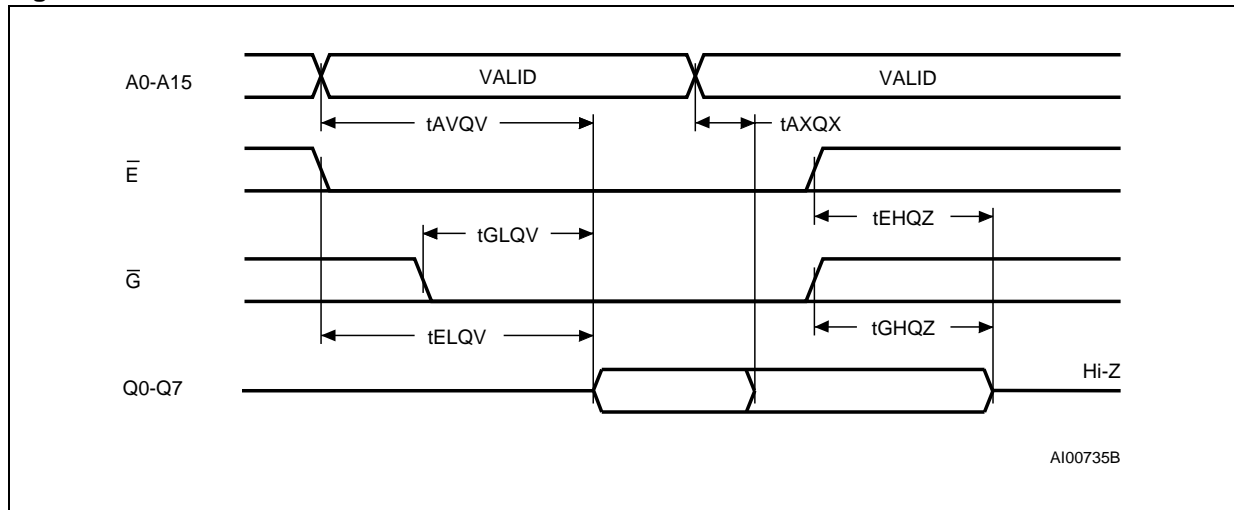

Table 11. Programming mode DC characteristics

Symbol	Parameter	Test Condition <sup>(1)(2)</sup>	Min	Max	Unit
$I_{LI}$	Input Leakage Current	$V_{IL} \leq V_{IN} \leq V_{IH}$		$\pm 10$	$\mu A$
$I_{CC}$	Supply Current			50	mA
$I_{PP}$	Program Current	$\bar{E} = V_{IL}$		50	mA
$V_{IL}$	Input Low Voltage		-0.3	0.8	V
$V_{IH}$	Input High Voltage		2	$V_{CC} + 0.5$	V
$V_{OL}$	Output Low Voltage	$I_{OL} = 2.1mA$		0.4	V
$V_{OH}$	Output High Voltage TTL	$I_{OH} = -1mA$	3.6		V
$V_{ID}$	A9 Voltage		11.5	12.5	V

- $T_A = 25\text{ }^\circ C$ ;  $V_{CC} = 6.25V \pm 0.25V$ ;  $V_{PP} = 12.75V \pm 0.25V$
- $V_{CC}$  must be applied simultaneously with or before  $V_{PP}$  and removed simultaneously or after  $V_{PP}$ .

Table 12. Margin Mode AC Characteristics

Symbol	Alt	Parameter	Test Condition <sup>(1)(2)</sup>	Min	Max	Unit
$t_{A9HVPH}$	$t_{AS9}$	$V_{A9}$ High to $V_{PP}$ High		2		$\mu s$
$t_{VPHEL}$	$t_{VPS}$	$V_{PP}$ High to Chip Enable Low		2		$\mu s$
$t_{A10HEH}$	$t_{AS10}$	$V_{A10}$ High to Chip Enable High (Set)		1		$\mu s$
$t_{A10LEH}$	$t_{AS10}$	$V_{A10}$ Low to Chip Enable High (Reset)		1		$\mu s$
$t_{EXA10X}$	$t_{AH10}$	Chip Enable Transition to $V_{A10}$ Transition		1		$\mu s$
$t_{EXVPX}$	$t_{VPH}$	Chip Enable Transition to $V_{PP}$ Transition		2		$\mu s$
$t_{VPXA9X}$	$t_{AH9}$	$V_{PP}$ Transition to $V_{A9}$ Transition		2		$\mu s$

- $T_A = 25\text{ }^\circ C$ ;  $V_{CC} = 6.25V \pm 0.25V$ ;  $V_{PP} = 12.75V \pm 0.25V$
- $V_{CC}$  must be applied simultaneously with or before  $V_{PP}$  and removed simultaneously or after  $V_{PP}$ .

Figure 8. Margin mode AC waveforms



1.  $A_8$  High level = 5V;  $A_9$  High level = 12V.

**Table 13. Programming mode AC characteristics**

Symbol	Alt	Parameter	Test Condition <sup>(1)(2)</sup>	Min	Max	Unit
$t_{AVEL}$	$t_{AS}$	Address Valid to Chip Enable Low		2		$\mu s$
$t_{QVEL}$	$t_{DS}$	Input Valid to Chip Enable Low		2		$\mu s$
$t_{VCHEL}$	$t_{VCS}$	$V_{CC}$ High to Chip Enable Low		2		$\mu s$
$t_{VPHEL}$	$t_{OES}$	$V_{PP}$ High to Chip Enable Low		2		$\mu s$
$t_{VPLVPH}$	$t_{PRT}$	$V_{PP}$ Rise Time		50		ns
$t_{ELEH}$	$t_{PW}$	Chip Enable Program Pulse Width (Initial)		95	105	$\mu s$
$t_{EHQX}$	$t_{DH}$	Chip Enable High to Input Transition		2		$\mu s$
$t_{EHVPX}$	$t_{OEH}$	Chip Enable High to $V_{PP}$ Transition		2		$\mu s$
$t_{VPLEL}$	$t_{VR}$	$V_{PP}$ Low to Chip Enable Low		2		$\mu s$
$t_{ELQV}$	$t_{DV}$	Chip Enable Low to Output Valid			1	$\mu s$
$t_{EHQZ}^{(3)}$	$t_{DFP}$	Chip Enable High to Output Hi-Z		0	130	ns
$t_{EHAX}$	$t_{AH}$	Chip Enable High to Address Transition		0		ns

1.  $T_A = 25\text{ }^\circ\text{C}$ ;  $V_{CC} = 6.25\text{V} \pm 0.25\text{V}$ ;  $V_{PP} = 12.75\text{V} \pm 0.25\text{V}$
2.  $V_{CC}$  must be applied simultaneously with or before  $V_{PP}$  and removed simultaneously or after  $V_{PP}$ .
3. Sampled only, not 100% tested.

**Figure 9. Programming and Verify modes AC waveforms**



AI00737

## 6 Package mechanical

Figure 10. FDIP28W - 28 pin Ceramic Frit-seal DIP, with window, Package Outline

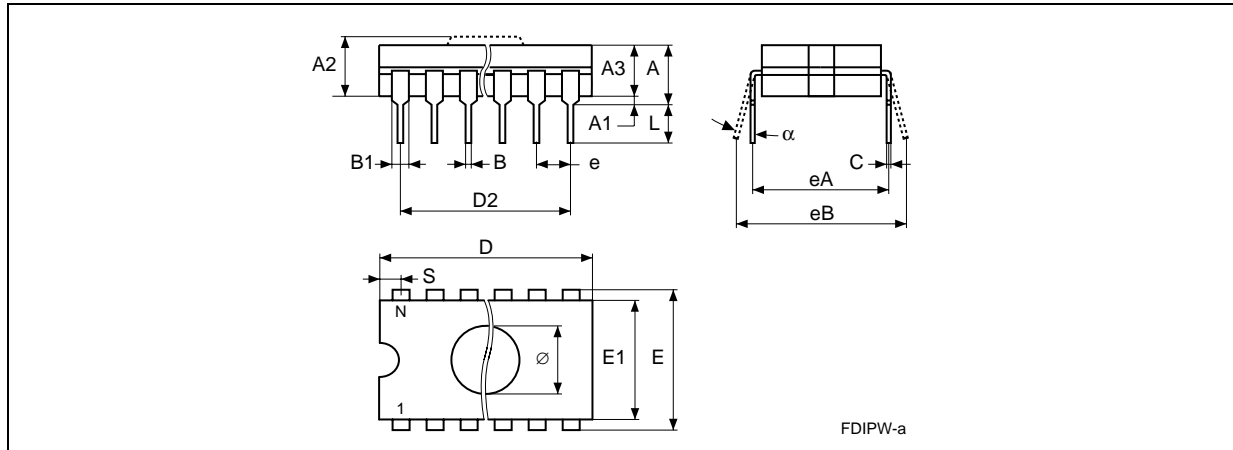

1. Drawing is not to scale.

Table 14. FDIP28W - 28 pin Ceramic Frit-seal DIP, with window, Package Mechanical Data

Symbol	millimeters			inches			
	Typ	Min	Max	Typ	Min	Max	
A			5.72			0.225	
A1		0.51	1.40		0.020	0.055	
A2		3.91	4.57		0.154	0.180	
A3		3.89	4.50		0.153	0.177	
B		0.41	0.56		0.016	0.022	
B1	1.45	–	–	0.057	–	–	
C		0.23	0.30		0.009	0.012	
D		36.50	37.34		1.437	1.470	
D2	33.02	–	–	1.300	–	–	
E	15.24	–	–	0.600	–	–	
E1		13.06	13.36		0.514	0.526	
e	2.54	–	–	0.100	–	–	
eA	14.99	–	–	0.590	–	–	
eB		16.18	18.03		0.637	0.710	
L		3.18	4.10		0.125	0.161	
S		1.52	2.49		0.060	0.098	
Ø	7.11	–	–	0.280	–	–	
α		4°	11°		4°	11°	
N		28				28	

Figure 11. PDIP28 - 28 pin Plastic DIP, 600 mils width, Package Outline



1. Drawing is not to scale.

Table 15. PDIP28 - 28 pin Plastic DIP, 600 mils width, Package Mechanical Data

Symbol	millimeters			inches		
	Typ	Min	Max	Typ	Min	Max
A	4.445			0.1750		
A1	0.630			0.0248		
A2	3.810	3.050	4.570	0.1500	0.1201	0.1799
B	0.450			0.0177		
B1	1.270			0.0500		
C		0.230	0.310		0.0091	0.0122
D	36.830	36.580	37.080	1.4500	1.4402	1.4598
D2	33.020	-	-	1.3000	-	-
E	15.240			0.6000		
E1	13.720	12.700	14.480	0.5402	0.5000	0.5701
e1	2.540	-	-	0.1000	-	-
eA	15.000	14.800	15.200	0.5906	0.5827	0.5984
eB		15.200	16.680		0.5984	0.6567
L	3.300			0.1299		
S		1.78	2.08		0.070	0.082
$\alpha$		0°	10°		0°	10°
N	28			28		

Figure 12. PLCC32 - 32 lead Plastic Leaded Chip Carrier, Package Outline



1. Drawing is not to scale.

Table 16. PLCC32 - 32 lead Plastic Leaded Chip Carrier, Package Mechanical Data

Symbol	millimeters			inches		
	Typ	Min	Max	Typ	Min	Max
A		3.18	3.56		0.125	0.140
A1		1.53	2.41		0.060	0.095
A2		0.38	–		0.015	–
B		0.33	0.53		0.013	0.021
B1		0.66	0.81		0.026	0.032
CP			0.10			0.004
D		12.32	12.57		0.485	0.495
D1		11.35	11.51		0.447	0.453
D2		4.78	5.66		0.188	0.223
D3	7.62	–	–	0.300	–	–
E		14.86	15.11		0.585	0.595
E1		13.89	14.05		0.547	0.553
E2		6.05	6.93		0.238	0.273
E3	10.16	–	–	0.400	–	–
e	1.27	–	–	0.050	–	–
F		0.00	0.13		0.000	0.005
R	0.89	–	–	0.035	–	–
N		32			32	

# 7 Part numbering

**Table 17. Ordering Information Scheme**



1. High Speed, see AC Characteristics section for further information.

For a list of available options (speed, package, etc.) or for further information on any aspect of this device, please contact your nearest ST Sales Office.

## 8 Revision history

**Table 18. Document revision history**

Date	Revision	Changes
November 1998	1.0	First Issue
25-Sep-2000	1.1	AN620 Reference removed
02-Apr-2001	1.2	FDIP28W mechanical dimensions changed (<Blue>Table 14.)
29-Aug-2002	1.3	Package mechanical data clarified for PDIP28 ( <a href="#">Table 15</a> ), PLCC32 ( <a href="#">Table 16</a> , <a href="#">Figure 12</a> ) and TSOP28 (Table 16., Figure 7.)
08-Nov-2004	2.0	Details of ECOPACK lead-free package options added. Additional Burn-in option removed
18-May-2007	3	ECOPACK lead-free text updated in <a href="#">Section 1: Description</a> . TLEAD and Note 1 removed from <a href="#">Table 5: Absolute maximum ratings</a> . TSOP28 package removed. 60, 80, 200 and 250 access times removed from the whole document. Blank, TR, E, and F Options removed from <a href="#">Table 17: Ordering Information Scheme</a> .

**Please Read Carefully:**

Information in this document is provided solely in connection with ST products. STMicroelectronics NV and its subsidiaries ("ST") reserve the right to make changes, corrections, modifications or improvements, to this document, and the products and services described herein at any time, without notice.

All ST products are sold pursuant to ST's terms and conditions of sale.

Purchasers are solely responsible for the choice, selection and use of the ST products and services described herein, and ST assumes no liability whatsoever relating to the choice, selection or use of the ST products and services described herein.

No license, express or implied, by estoppel or otherwise, to any intellectual property rights is granted under this document. If any part of this document refers to any third party products or services it shall not be deemed a license grant by ST for the use of such third party products or services, or any intellectual property contained therein or considered as a warranty covering the use in any manner whatsoever of such third party products or services or any intellectual property contained therein.

**UNLESS OTHERWISE SET FORTH IN ST'S TERMS AND CONDITIONS OF SALE ST DISCLAIMS ANY EXPRESS OR IMPLIED WARRANTY WITH RESPECT TO THE USE AND/OR SALE OF ST PRODUCTS INCLUDING WITHOUT LIMITATION IMPLIED WARRANTIES OF MERCHANTABILITY, FITNESS FOR A PARTICULAR PURPOSE (AND THEIR EQUIVALENTS UNDER THE LAWS OF ANY JURISDICTION), OR INFRINGEMENT OF ANY PATENT, COPYRIGHT OR OTHER INTELLECTUAL PROPERTY RIGHT.**

**UNLESS EXPRESSLY APPROVED IN WRITING BY AN AUTHORIZED ST REPRESENTATIVE, ST PRODUCTS ARE NOT RECOMMENDED, AUTHORIZED OR WARRANTED FOR USE IN MILITARY, AIR CRAFT, SPACE, LIFE SAVING, OR LIFE SUSTAINING APPLICATIONS, NOR IN PRODUCTS OR SYSTEMS WHERE FAILURE OR MALFUNCTION MAY RESULT IN PERSONAL INJURY, DEATH, OR SEVERE PROPERTY OR ENVIRONMENTAL DAMAGE. ST PRODUCTS WHICH ARE NOT SPECIFIED AS "AUTOMOTIVE GRADE" MAY ONLY BE USED IN AUTOMOTIVE APPLICATIONS AT USER'S OWN RISK.**

Resale of ST products with provisions different from the statements and/or technical features set forth in this document shall immediately void any warranty granted by ST for the ST product or service described herein and shall not create or extend in any manner whatsoever, any liability of ST.

ST and the ST logo are trademarks or registered trademarks of ST in various countries.

Information in this document supersedes and replaces all information previously supplied.

The ST logo is a registered trademark of STMicroelectronics. All other names are the property of their respective owners.

© 2007 STMicroelectronics - All rights reserved



STMicroelectronics group of companies

Australia - Belgium - Brazil - Canada - China - Czech Republic - Finland - France - Germany - Hong Kong - India - Israel - Italy - Japan - Malaysia - Malta - Morocco - Singapore - Spain - Sweden - Switzerland - United Kingdom - United States of America

[www.st.com](http://www.st.com)

## Looking for pricing, stock, or lifecycle information?

Click below to explore more details on WIN SOURCE:

-  [View M27C512-90B1](#) on WIN SOURCE
-  [STMicroelectronics](#) Information

## Optimize Your Supply Chain with WIN SOURCE Solutions

-  Global Sourcing Solution
-  Obsolete Management
-  Cost Control Management
-  Shortage Management
-  Alternative Solution
-  Excess Inventory Management