



**THE DATASHEET OF
AT17F080A-30CU**



Features

- Programmable 4,194,304 x 1 and 8,388,608 x 1-bit Serial Memories Designed to Store Configuration Programs for Field Programmable Gate Arrays (FPGAs)
- 3.3V Output Capability
- 5.0V Tolerant I/O Pins
- Program Support using the Atmel ATDH2200E System, ATDH2225 ISP cable, or Third-party Programmers
- In-System Programmable (ISP) via 2-wire Bus
- Simple Interface to SRAM FPGAs
- Compatible with Atmel AT40K and AT94K Devices, Altera® FLEX®, Excalibur™, Stratix®, Cyclone™, and APEX™ Devices
- Cascadable Read-back to Support Additional Configurations or Higher-density Arrays
- Low-power CMOS FLASH Process
- Available in 8-pad LAP and 20-lead PLCC Packages
- Emulation of the Atmel AT24C Serial EEPROMs
- Low-power Standby Mode
- Single Device Capable of Holding 4-Bitstream Files Allowing Simple System Reconfiguration
- Fast Serial Download Speeds up to 33MHz
- Endurance: 100,000 Write Cycles Typical
- Green (Lead/Halide-free/ROHS compliant) Package Options

Description

The Atmel® AT17FxxxA Series of In-System Programmable Configuration PROMs (Configurators) provide an easy-to-use, cost-effective configuration memory solution for FPGAs. The AT17FxxxA Series devices are packaged in the 8-pad LAP and 20-lead PLCC (Table 1-1). The AT17FxxxA Series Configurators use a simple serial-access procedure to configure one or more FPGA devices.

The AT17FxxxA Series Configurators can be programmed with industry-standard programmers, the Atmel ATDH2200E Programming Kit or the Atmel ATDH2225 ISP Cable.

Table 1. AT17FxxxA Series Packages

Package	AT17F040A	AT17F080A
8-pad LAP	Yes	Yes
20-lead PLCC	Yes	Yes

1. Pin Configurations

Table 1-1. Pin Descriptions

Pin	Description
DATA ⁽¹⁾	Three-state DATA output for FPGA Configuration. Open-collector bi-directional pin for configuration programming.
DCLK ⁽¹⁾	Three-state Clock. Functions as an input when the Configurator is in programming mode (i.e. SER_EN is Low) and as an output during FPGA configuration.
PAGE_EN ⁽²⁾	Enable Page Download Mode Input. When PAGE_EN is high the configuration download address space is partitioned into four equal pages. This gives users the ability to easily store and retrieve multiple configuration bitstreams from a single configuration device. This input works in conjunction with the PAGESEL inputs. PAGE_EN must be remain low if paging is not desired. When SER_EN is Low (ISP mode) this pin has no effect.
PAGESEL[1:0] ⁽²⁾	Page Select Inputs. Used to determine which of the four memory pages are targeted during a serial configuration download. The address space for each of the pages is shown in Table 1-2. When SER_EN is Low (ISP mode) these pins have no effect.
RESET/OE ⁽¹⁾	Output Enable (Active High) and RESET (Active Low) when SER_EN is High. A Low level on RESET/OE resets both the address and bit counters. A High level (with nCS Low) enables the data output driver.
nCS ⁽¹⁾	Chip Enable Input (Active Low). A Low level (with OE High) allows DCLK to increment the address counter and enables the data output driver. A High level on nCS disables both the address and bit counters and forces the device into a low-power standby mode. Note that this pin will <i>not</i> enable/disable the device in the 2-wire Serial Programming mode (SER_EN Low).
GND	Ground. A 0.2µF decoupling capacitor between V _{CC} and GND is recommended.
nCASC	Cascade Select Output (when SER_EN is High). This output goes Low when the internal address counter has reached its maximum value. If the PAGE_EN input is set High, the maximum value is the highest address in the selected partition. The PAGESEL[1:0] inputs are used to make the four partition selections. If the PAGE_EN input is set Low, the device is not partitioned and the address maximum value is the highest address in the device (Table 1-2). In a daisy chain of the AT17FxxxA Series devices, the nCASC pin of one device must be connected to the nCS input of the next device in the chain. It will stay Low as long as nCS is Low and OE is High. It will then follow nCS until OE goes Low; thereafter, nCASC will stay High until the entire EEPROM is read again.
A2 ⁽¹⁾	Device Selection Input, (when SER_EN Low). The input is used to enable (or chip select) the device during programming (i.e., when SER_EN is Low). Refer to the Atmel AT17FxxxA Programming Specification available at www.atmel.com for additional details.
READY	Open Collector Reset State Indicator. Driven Low during power-up reset, released when power-up is complete. (recommended 4.7kΩ pull-up on this pin if used).
SER_EN ⁽¹⁾	Serial Enable Input. Must remain High during FPGA configuration operations. Bringing SER_EN Low enables the 2-Wire Serial Programming Mode. For non-ISP applications, SER_EN should be tied to V _{CC} .
V _{CC}	Device Power Supply. +3.3V (±10%)

- Notes: 1. Internal 20KΩ pull-up resistor
 2. Internal 30KΩ pull-up resistor

Table 1-2. Address Space (PAGESEL[1:0])

Paging Decodes	AT17F040A (4Mb)	AT17F080A (8Mb)
PAGESEL = 00, PAGE_EN = 1	00000 – 0FFFFh	00000 – 1FFFFh
PAGESEL = 01, PAGE_EN = 1	10000 – 1FFFFh	20000 – 3FFFFh
PAGESEL = 10, PAGE_EN = 1	20000 – 2FFFFh	40000 – 5FFFFh
PAGESEL = 11, PAGE_EN = 1	30000 – 3FFFFh	60000 – 7FFFFh
PAGESEL = XX, PAGE_EN = 0	00000 – 3FFFFh	00000 – 7FFFFh

Table 1-3. Pin Configurations

Name	I/O	8-pad LAP	20-lead PLCC
DATA	I/O	1	2
DCLK	I	2	4
PAGE_EN	I	—	16
PAGESEL0	I	—	11
PAGESEL1	I	—	7
RESET/OE	I	3	8
nCS	I	4	9
GND	—	5	10
nCASC	O	6	12
A2	I	6	12
READY	O	—	15
SER_EN	I	7	18
V _{CC}	—	8	20

Figure 1-1. Pinouts

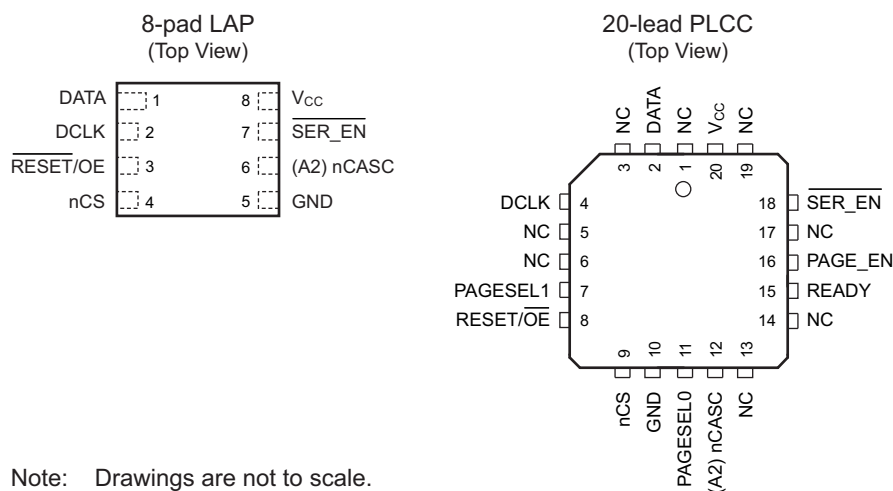

Note: Drawings are not to scale.

2. Block Diagram

Figure 2-1. Block Diagram

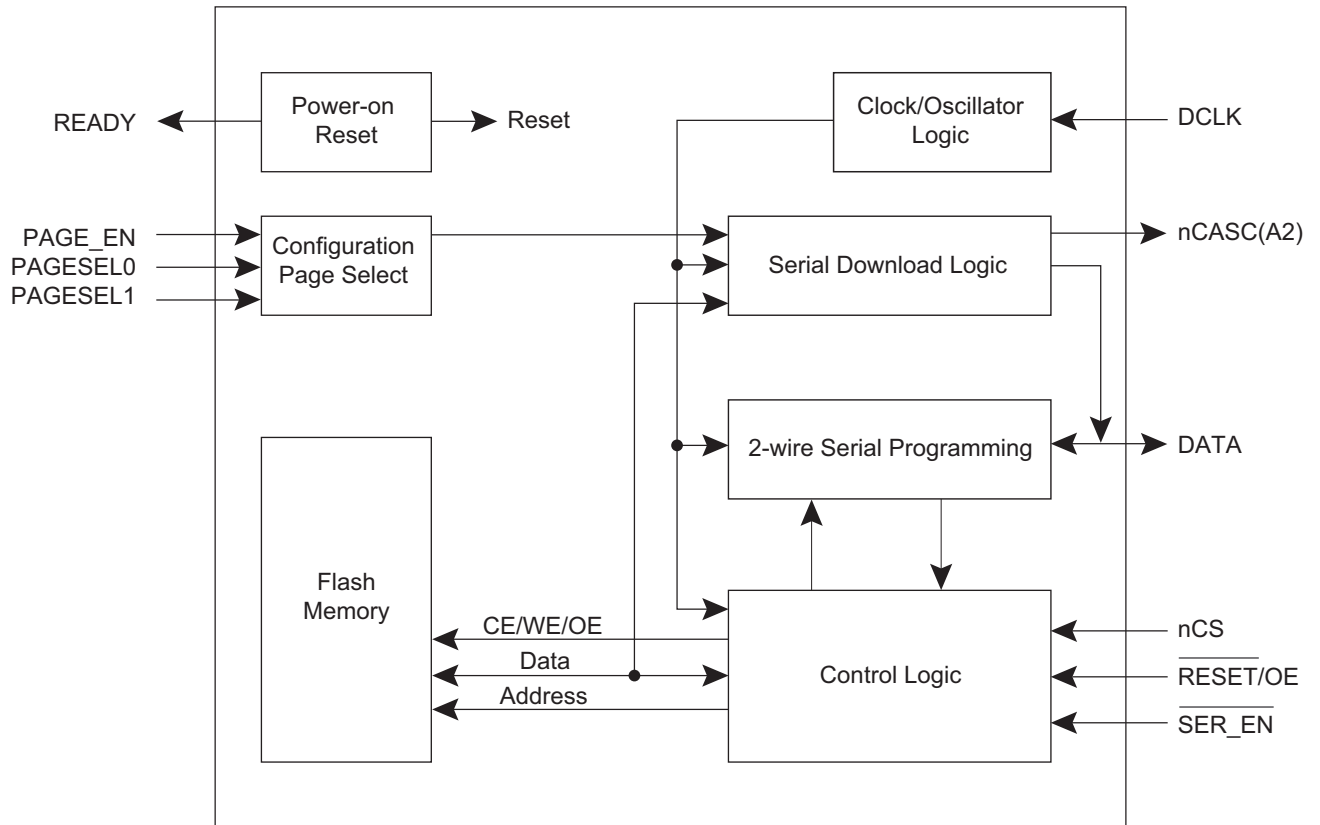

3. Device Description

The control signals for the configuration memory device (nCS, $\overline{\text{RESET/OE}}$ and DCLK) interface directly with the FPGA device control signals. All FPGA devices can control the entire configuration process and retrieve data from the configuration device without requiring an external intelligent controller.

The $\overline{\text{RESET/OE}}$ and nCS pins control the tri-state buffer on the DATA output pin and enable the address counter. When $\overline{\text{RESET/OE}}$ is driven Low, the configuration device resets its address counter and tri-states its DATA pin. The nCS pin also controls the output of the AT17FxxxA Series Configurator. If nCS is held High after the $\overline{\text{RESET/OE}}$ reset pulse, the counter is disabled and the DATA output pin is tri-stated. When OE is subsequently driven High, the counter and the DATA output pin are enabled. When $\overline{\text{RESET/OE}}$ is driven Low again, the address counter is reset and the DATA output pin is tri-stated, regardless of the state of nCS.

When the configurator has driven out all of its data and nCASC is driven Low, the device tri-states the DATA pin to avoid contention with other configurators. Upon power-up, the address counter is automatically reset.

4. FPGA Master Serial Mode Summary

The I/O and logic functions of any SRAM-based FPGA are established by a configuration program. The program is loaded either automatically upon power-up or on command, depending on the state of the FPGA mode pins. In Master mode, the FPGA automatically loads the configuration program from an external memory. The AT17FxxxA Serial Configuration PROM has been designed for compatibility with the Master Serial mode. This document discusses the Atmel AT40K, AT40KAL and AT94KAL applications as well as Altera applications.

5. Control of Configuration

Most connections between the FPGA device and the AT17FxxxA Serial Configurator PROM are simple and self-explanatory.

- The DATA output of the AT17FxxxA Series Configurator drives DIN of the FPGA devices.
- The DCLK output of the AT17FxxxA drives the DCLK input data of the FPGA.
- The nCASC output of a AT17FxxxA Series Configurator drives the nCS input of the next Configurator in a cascade chain of configurator devices.
- $\overline{\text{SER_EN}}$ must be at logic High level (internal pull-up resistor provided) except during ISP.
- The READY pin is available as an open-collector indicator of the device's reset status; it is driven Low while the device is in its power-on reset cycle and released (tri-stated) when the cycle is complete.
- PAGE_EN must REMAIN Low if download paging is not desired. If paging is desired, PAGE_EN must be High and the PAGESEL pins must be set to High or Low such that the desired page is selected (Table 1-2).

6. Cascading Serial Configuration Devices

For multiple FPGAs configured as a daisy-chain or for FPGAs requiring larger configuration memories, cascaded configurators provide additional memory.

After the last bit from the first configurator is read, the clock signal to the configurator asserts its nCASC output Low and disables its DATA line driver. The second configurator recognizes the Low level on its nCS input and enables its DATA output.

After configuration is complete, the address counters of all cascaded configurators are reset if the $\overline{\text{RESET/OE}}$ on each configurator is driven to its active (Low) level.

If the address counters are not to be reset upon completion, then the $\overline{\text{RESET/OE}}$ input can be tied to its inactive (High) level.

7. Programming Mode

The programming mode is entered by bringing $\overline{\text{SER_EN}}$ Low. In this mode, the chip can be programmed by the 2-wire serial bus. The programming is done at V_{CC} supply only. Programming super voltages are generated inside the chip. The AT17FxxxA parts are read/write at 3.3V nominal. Refer to the Atmel AT17FxxxA Programming Specification available at www.atmel.com for more programming details. The AT17FxxxA devices are supported by the ATDH2200 programming system along with many third party programmers.

8. Standby Mode

The AT17FxxxA Series Configurators enter a low-power standby mode whenever $\overline{\text{SER_EN}}$ is High and nCS is asserted High. In this mode, the AT17FxxxA Configurator typically consumes less than 3mA of current at 3.3V. The output remains in a high-impedance state regardless of the state of the OE input.

9. Electrical Specifications

9.1 Absolute Maximum Ratings*

Operating Temperature	-40°C to +85°C
Storage Temperature	-65°C to +150°C
Voltage on Any Pin with Respect to Ground	-0.5V to $V_{CC} + 0.5V$
Supply Voltage (V_{CC})	-0.5V to +4.0V
Maximum Soldering Temp. (10 sec. @ 1/16in.)	260°C
ESD ($R_{ZAP} = 1.5K, C_{ZAP} = 100pF$)	2000V

*Notice: Stresses beyond those listed under Absolute Maximum Ratings may cause permanent damage to the device. This is a stress rating only and functional operation of the device at these or any other conditions beyond those listed under operating conditions is not implied. Exposure to Absolute Maximum Rating conditions for extended periods of time may affect device reliability.

9.2 Operating Conditions

Table 9-1. Operating Conditions

Symbol	Description	Min	Max	Units
V_{CC}	Supply voltage relative to GND -40°C to +85°C	2.97	3.63	V

9.3 DC Characteristics

Table 9-2. DC Characteristics

Symbol	Description	AT17F040A		AT17F080A		Units
		Min	Max	Min	Max	
V_{IH}	High-level Input Voltage	2.0	V_{CC}	2.0	V_{CC}	V
V_{IL}	Low-level Input Voltage	0	0.8	0	0.8	V
V_{OH}	High-level Output Voltage ($I_{OH} = -2mA$)	2.4		2.4		V
V_{OL}	Low-level Output Voltage ($I_{OL} = +3mA$)		0.4		0.4	V
I_{CCA}	Supply Current, Active Mode at Freq. Max.		50		50	mA
I_L	Input or Output Leakage Current ($V_{IN} = V_{CC}$ or GND)	-10	10	-10	10	μA
I_{CCS}	Supply Current, Standby Mode		3		3	mA

9.4 AC Characteristics

Table 9-3. AC Characteristics

Symbol	Description	AT17F040A/080A			Units
		Min	Typ	Max	
$T_{OE}^{(1)}$	OE to Data Delay			55	ns
$T_{CE}^{(1)}$	nCS to Data Delay			60	ns
$T_{CAC}^{(1)}$	DCLK to Data Delay			30	ns
T_{OH}	Data Hold from nCS, OE, or DCLK	0			ns
$T_{DF}^{(2)}$	nCS or OE to Data Float Delay			15	ns
T_{LC}	DCLK Low Time	15			ns
T_{HC}	DCLK High Time	15			ns
T_{SCE}	nCS Setup Time to DCLK (to guarantee proper counting)	25			ns
T_{HCE}	nCS Hold Time from DCLK (to guarantee proper counting)	0			ns
T_{HOE}	$\overline{RESET/OE}$ Low Time (guarantees counter is reset)	20			ns
F_{MAX}	Maximum Input Clock Frequency $\overline{SEREN} = 0$			10	MHz
T_{WR}	Write Cycle Time ⁽³⁾		12		μ s
T_{EC}	Erase Cycle Time ⁽³⁾		33		s

- Notes:
1. AC test load = 50pF
 2. Float delays are measured with 5pF AC loads. Transition is measured ± 200 mV from steady-state active levels.
 3. Reference the Atmel AT17Fxxx A Programming Specification for procedural information.

Table 9-4. AC Characteristics When Cascading

Symbol	Description	AT17F040A		AT17F080A		Units
		Min	Max	Min	Max	
$T_{CDF}^{(2)}$	DCLK to Data Float Delay		50		50	ns
$T_{OCK}^{(1)}$	DCLK to nCASC Delay		55		55	ns
$T_{OCE}^{(1)}$	\overline{nCS} to nCASC Delay		40		40	ns
$T_{OOE}^{(1)}$	$\overline{RESET/OE}$ to nCASC Delay		25		35	ns

- Notes:
1. AC test load = 50pF
 2. Float delays are measured with 5pF AC loads. Transition is measured ± 200 mV from steady-state active levels.

Figure 9-1. AC Waveforms

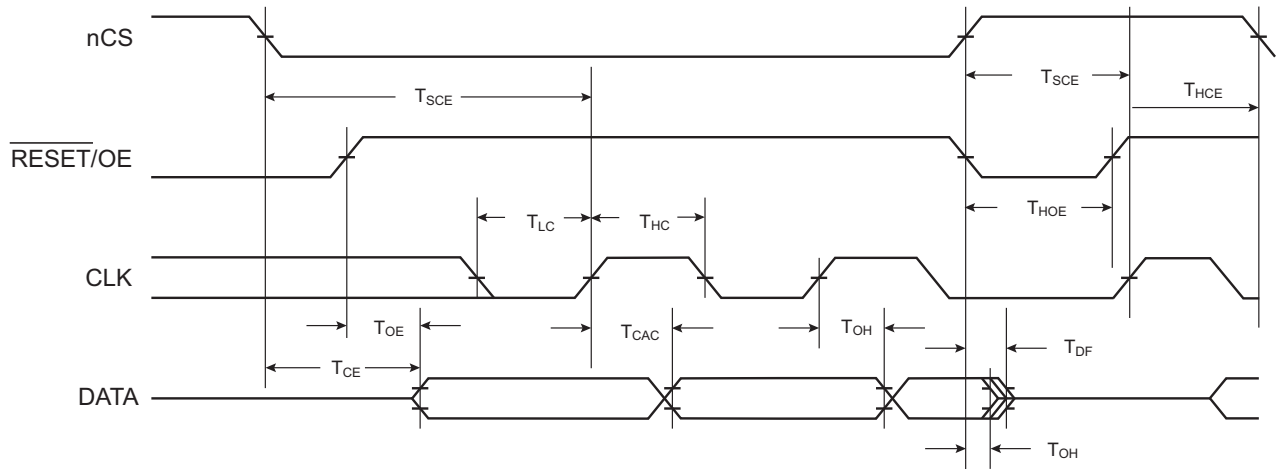
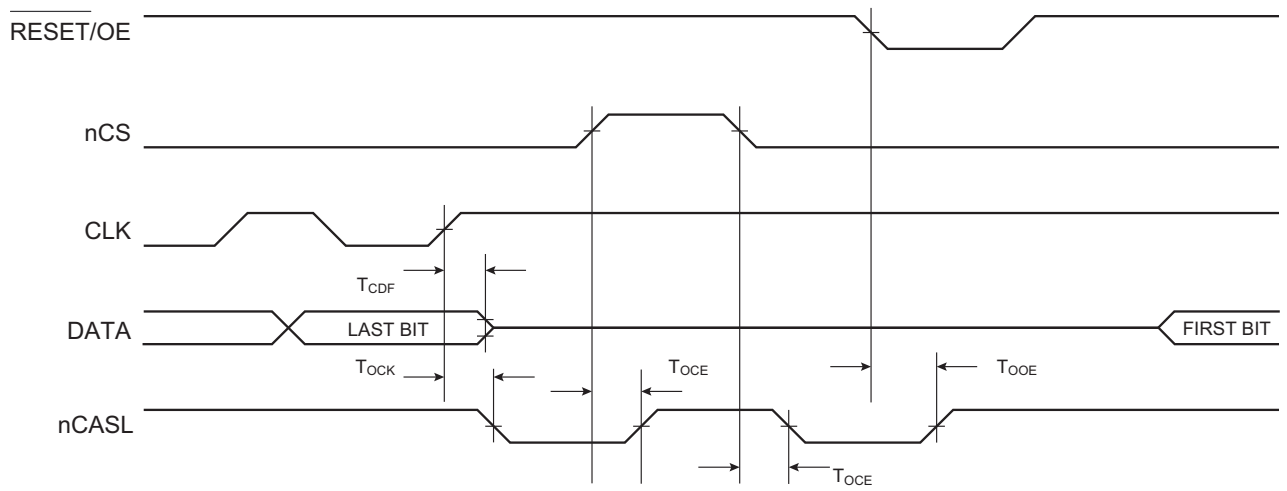
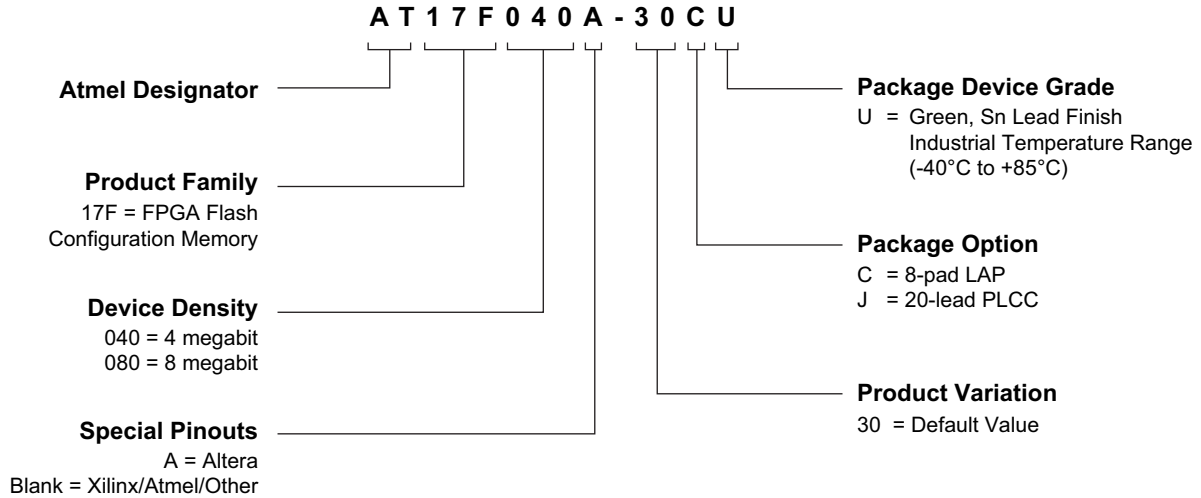

Figure 9-2. AC Waveforms when Cascading



10. Ordering Information

10.1 Ordering Code Detail



10.2 Ordering Information

Memory Size	Atmel Ordering Code	Lead Finish	Package	Voltage	Operation Range
4-Mbit	AT17F040A-30CU	Sn (Lead-free/Halogen-free)	8CN4	3.3V	Industrial (-40°C to 85°C)
	AT17F040A-30JU		20J		
8-Mbit	AT17F080A-30CU	Sn (Lead-free/Halogen-free)	8CN4	3.3V	Industrial (-40°C to 85°C)
	AT17F080A-30JU		20J		

Package Type	
8CN4	8-pad, 6.00mm x 6.00mm x 1.04mm, Leadless Array Package (LAP) Pin-compatible with 8-lead SOIC/VOIC Packages
20J	20-lead, Plastic J-leaded Chip Carrier (PLCC)

11. Packaging Information

11.1 8CN4 — 8-pad LAP

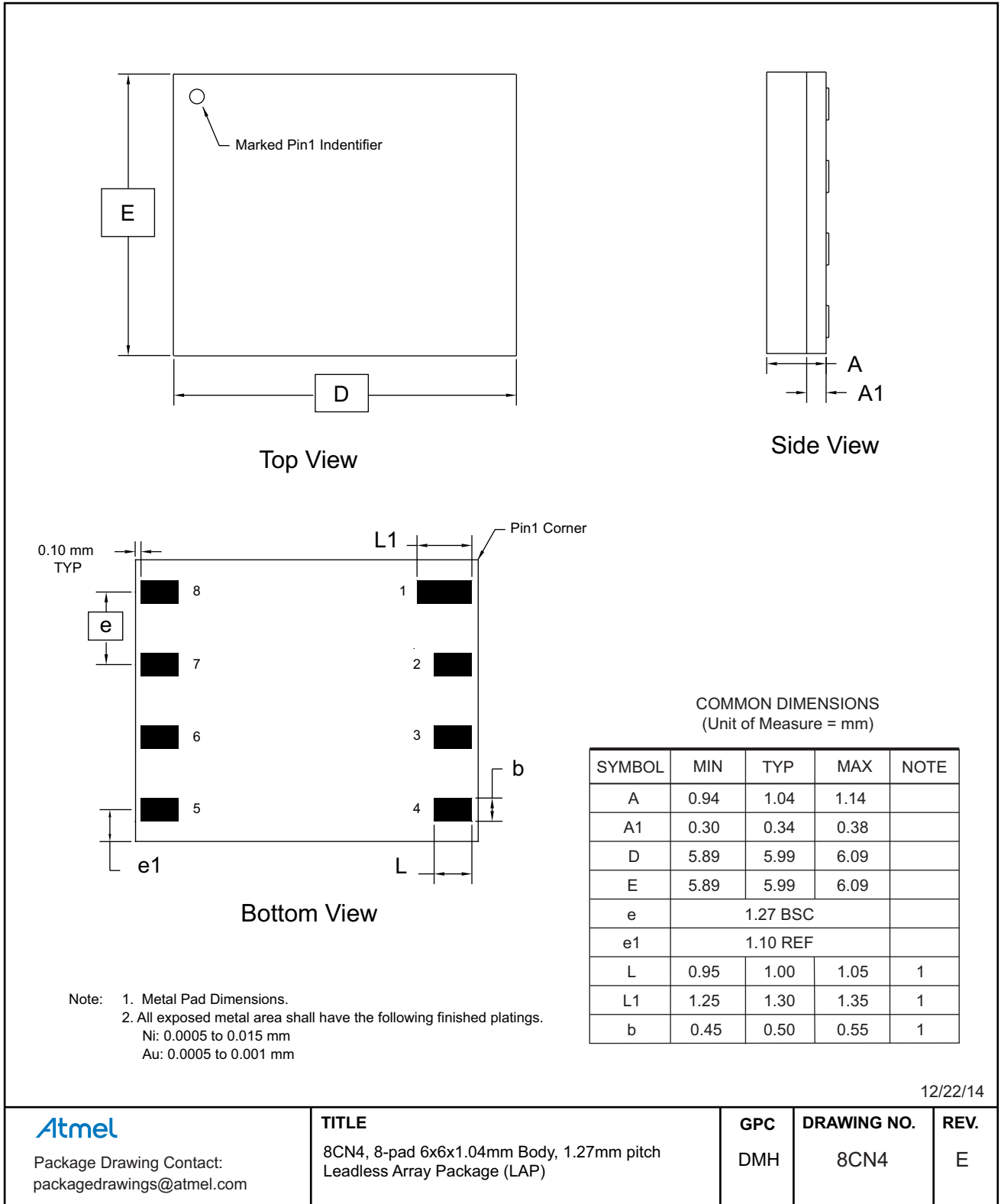

11.2 20J — 20-lead PLCC

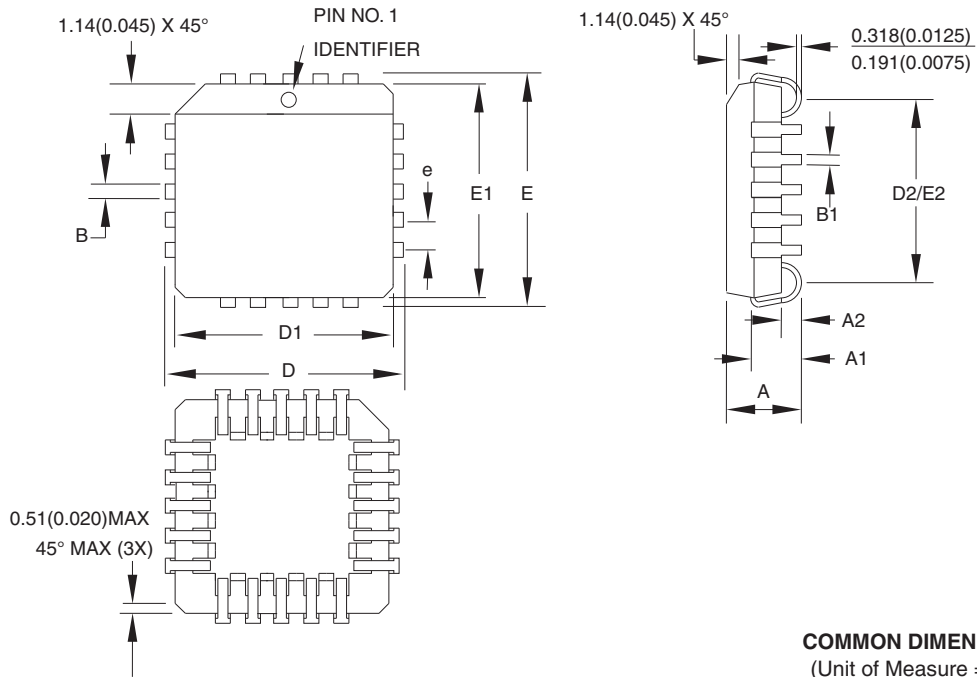

COMMON DIMENSIONS
(Unit of Measure = mm)

SYMBOL	MIN	NOM	MAX	NOTE
A	4.191	—	4.572	
A1	2.286	—	3.048	
A2	0.508	—	—	
D	9.779	—	10.033	
D1	8.890	—	9.042	Note 2
E	9.779	—	10.033	
E1	8.890	—	9.042	Note 2
D2/E2	7.366	—	8.382	
B	0.660	—	0.813	
B1	0.330	—	0.533	
e	1.270 TYP			

- Notes:
1. This package conforms to JEDEC reference MS-018, Variation AA
 2. Dimensions $D1$ and $E1$ do not include mold protrusion. Allowable protrusion is $.010"$ (0.254mm) per side. Dimension $D1$ and $E1$ include mold mismatch and are measured at the extreme material condition at the upper or lower parting line.
 3. Lead coplanarity is $0.004"$ (0.102mm) maximum

10/04/01

Atmel

Package Drawing Contact:
packagedrawings@atmel.com

TITLE

20J, 20-lead, Plastic J-leaded Chip Carrier (PLCC)

DRAWING NO.

20J

REV.

B

12. Revision History

Doc Rev	Date	Comments
2838F	01/2015	Removed commercial and 32-lead TQFP package options. Updated the 8CN4 package outline drawing, template, Atmel logos, and disclaimer page. Added an ordering code detail.
2823E	10/2010	Changed Endurance from 5,000 to 100,000 Changed Typ from 13 to 33 in AC Characteristics table

Looking for pricing, stock, or lifecycle information?

Click below to explore more details on WIN SOURCE:

- ⊖ [View AT17F080A-30CU on WIN SOURCE](#)
- ⊖ [Microchip Technology Information](#)

Optimize Your Supply Chain with WIN SOURCE Solutions

- ✓ Global Sourcing Solution
- ✓ Obsolete Management
- ✓ Cost Control Management
- ✓ Shortage Management
- ✓ Alternative Solution
- ✓ Excess Inventory Management