



**THE DATASHEET OF
AD9203WARUZ**



FEATURES

CMOS 10-bit, 40 MSPS sampling analog-to-digital converter
Power dissipation: 74 mW (3 V supply, 40 MSPS)
17 mW (3 V supply, 5 MSPS)
Operation between 2.7 V and 3.6 V supply
Differential nonlinearity: -0.25 LSB
Power-down (standby) mode: 0.65 mW
ENOB: 9.55 at $f_{IN} = 20$ MHz
Out-of-range indicator
Adjustable on-chip voltage reference
IF undersampling up to $f_{IN} = 130$ MHz
Input range: 1 V to 2 V p-p differential or single-ended
Adjustable power consumption
Internal clamp circuit
Qualified for automotive applications

APPLICATIONS

Automotive

GENERAL DESCRIPTION

The [AD9203W](#) is a monolithic low power, single supply, 10-bit, 40 MSPS analog-to-digital converter, with an on-chip voltage reference. The [AD9203W](#) uses a multistage differential pipeline architecture and guarantees no missing codes over the full operating temperature range. Its input range may be adjusted between 1 V and 2 V p-p.

The [AD9203W](#) has an onboard programmable reference. An external reference can also be chosen to suit the dc accuracy and temperature drift requirements of an application.

An external resistor can be used to reduce power consumption when operating at lower sampling rates. This yields power savings for users who do not require the maximum sample rate. This feature is especially useful at sample rates far below 40 MSPS. Excellent performance is still achieved at reduced power. For example, 9.7 ENOB performance may be realized with only 17 mW of power, using a 5 MHz clock.

A single clock input is used to control all internal conversion cycles. The digital output data is presented in straight binary or twos complementary output format by using the DFS pin. An out-of-range signal (OTR) indicates an overflow condition that

FUNCTIONAL BLOCK DIAGRAM

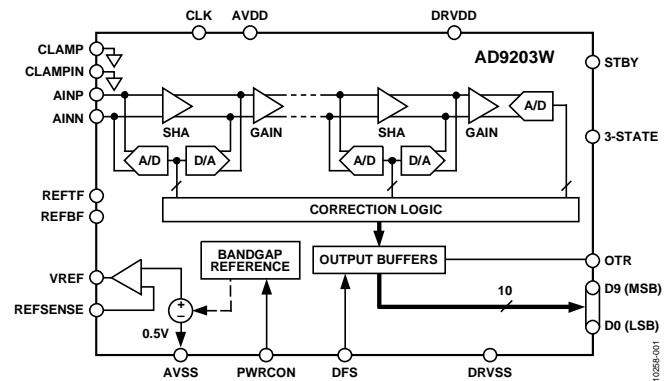

Figure 1.

can be used with the most significant bit to determine over- or underrange.

The [AD9203W](#) can operate with a supply range from 2.7 V to 3.6 V, an attractive option for low power operation in high speed portable applications.

The [AD9203W](#) is specified over industrial (-40°C to $+85^{\circ}\text{C}$) temperature ranges and is available in a 28-lead TSSOP package.

PRODUCT HIGHLIGHTS

1. **Low Power.** The [AD9203W](#) consumes 74 mW on a 3 V supply operating at 40 MSPS. In standby mode, power is reduced to 0.65 mW.
2. **High Performance.** Maintains better than 9.55 ENOB at 40 MSPS input signal from dc to Nyquist.
3. **Very Small Package.** The [AD9203W](#) is available in a 28-lead TSSOP.
4. **Programmable Power.** The [AD9203W](#) power can be further reduced by using an external resistor at lower sample rates.
5. **Built-In Clamp Function.** Allows dc restoration of video signals.

Rev. 0

Information furnished by Analog Devices is believed to be accurate and reliable. However, no responsibility is assumed by Analog Devices for its use, nor for any infringements of patents or other rights of third parties that may result from its use. Specifications subject to change without notice. No license is granted by implication or otherwise under any patent or patent rights of Analog Devices. Trademarks and registered trademarks are the property of their respective owners.

TABLE OF CONTENTS

Features	1	Thermal Characteristics	5
Functional Block Diagram	1	ESD Caution.....	5
General Description	1	Pin Configuration and Function Descriptions.....	6
Product Highlights	1	Outline Dimensions	7
Specifications.....	3	Ordering Guide	7
Absolute Maximum Ratings.....	5		

REVISION HISTORY

10/11—Revision 0: Initial Version

SPECIFICATIONS

AVDD = 3 V, DRVDD = 3 V, F_S = 40 MSPS, input span from 0.5 V to 2.5 V, internal 1 V reference, PWRCON = AVDD, 50% clock duty cycle, T_{MIN} to T_{MAX} unless otherwise noted.

Table 1.

Parameter	Symbol	Min	Typ	Max	Unit	Conditions
RESOLUTION			10		Bits	
MAX CONVERSION RATE	F _S	40			MSPS	
PIPELINE DELAY				5.5	Clock Cycles	
DC ACCURACY						
Differential Nonlinearity	DNL		±0.25	±0.7	LSB	
Integral Nonlinearity	INL		±0.65	±1.4	LSB	
Offset Error	E _{ZS}		±0.6	±2.8	% FSR	
Gain Error	E _{FS}		±0.7	±4.0	% FSR	
ANALOG INPUT						
Input Voltage Range	A _{IN}	1		2	V p-p	
Input Capacitance	C _{IN}		1.4		pF	
Aperture Delay	T _{AP}		2.0		ns	
Aperture Uncertainty (Jitter)	T _{AJ}		1.2		ps rms	
Input Bandwidth (−3 dB)	BW		390		MHz	
Input Referred Noise			0.3		mV	Switched, single-ended
INTERNAL REFERENCE						
Output Voltage (0.5 V Mode)	VREF		0.5		V	REFSENSE = VREF
Output Voltage (1 V Mode)	VREF		1		V	REFSENSE = GND
Output Voltage Tolerance (1 V Mode)			± 5	± 30	mV	
Load Regulation			0.65	1.2	mV	1.0 mA load
POWER SUPPLY						
Operating Voltage	AVDD	2.7	3.0	3.6	V	
	DRVDD	2.7	3.0	3.6	V	
Analog Supply Current	I _{AVDD}		20.1	22.0	mA	f _{IN} = 4.8 MHz, output bus load = 10 pF
Digital Supply Current	I _{DRVDD}		4.4	6.0	mA	f _{IN} = 20 MHz, output bus load = 20 pF
			9.5	14.0	mA	f _{IN} = 4.8 MHz, output bus load = 10pF
Power Consumption			74	84.0	mW	f _{IN} = 20 MHz, output bus load = 20 pF
			88.8	108.0	mW	
Power-Down	P _D		0.65	1.2	mW	
Power Supply Rejection Ratio	PSRR		0.04	± 0.25	% FSR	
DYNAMIC PERFORMANCE (A _{IN} = 0.5 dBFS)						
Signal-to-Noise and Distortion ¹	SINAD					
f = 4.8 MHz			59.7		dB	
f = 20 MHz		57.2	59.3		dB	
Effective Bits	ENOB					
f = 4.8 MHz ¹			9.6		Bits	
f = 20 MHz		9.2	9.55		Bits	
Signal-to-Noise Ratio	SNR					
f = 4.8 MHz ¹			60.0		dB	
f = 20 MHz		57.5	59.5		dB	
Total Harmonic Distortion	THD					
f = 4.8MHz			−76.0		dB	
f = 20 MHz			−74.0	−65.0	dB	
Spurious-Free Dynamic Range	SFDR					
f = 4.8 MHz ¹			80		dB	
f = 20 MHz		67.8	78		dB	

Parameter	Symbol	Min	Typ	Max	Unit	Conditions
Two-Tone Intermodulation Distortion	IMD		68		dB	f = 44.49 MHz and 45.52 MHz
Differential Phase	DP		0.2		Degree	NTSC 40 IRE ramp
Differential Gain	DG		0.3		%	
DIGITAL INPUTS						
High Input Voltage	V _{IH}	2.0			V	
Low Input Voltage	V _{IL}			0.4	V	
Clock Pulse Width High		11.25			ns	
Clock Pulse Width Low		11.25			ns	
Clock Period ²			25		ns	
DIGITAL OUTPUTS						
High-Z Leakage	I _{oZ}			± 5.0	μA	Output = 0 to DRVDD
Data Valid Delay	t _{OD}		5		ns	C _L = 20 pF
Data Enable Delay	t _{DEN}		6		ns	C _L = 20 pF
Data High-Z Delay	t _{DHZ}		6		ns	C _L = 20 pF
LOGIC OUTPUT (with DRVDD = 3 V)						
High Level Output Voltage (I _{OH} = 50 μA)	V _{OH}	2.95			V	
High Level Output Voltage (I _{OH} = 0.5 mA)	V _{OH}	2.80			V	
Low Level Output Voltage (I _{OL} = 1.6 mA)	V _{OL}			0.3	V	
Low Level Output Voltage (I _{OL} = 50 μA)	V _{OL}			0.05	V	

¹ Differential Input (2 V p-p).

² The AD9203W converts at clock rates as low as 20 kHz.

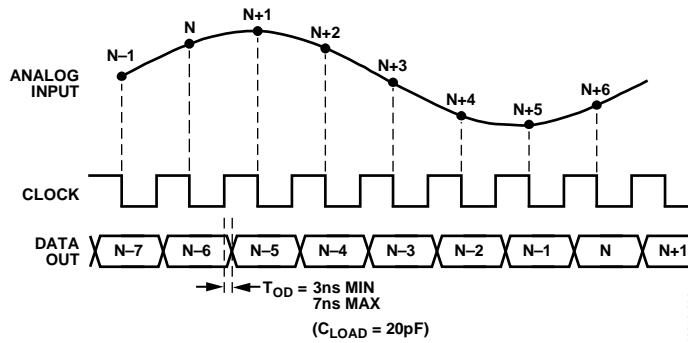

Figure 2. Timing Diagram

ABSOLUTE MAXIMUM RATINGS

Table 2.

Parameter	With Respect to	Rating	Unit
AVDD	AVSS	-0.3 to +3.9	V
DRVDD	DRVSS	-0.3 to +3.9	V
AVSS	DRVSS	-0.3 to +0.3	V
AVDD	DRVDD	-3.9 to +3.9	V
REFCOM	AVSS	-0.3 to +0.3	V
CLK	AVSS	-0.3 to AVDD + 0.3	V
Digital Outputs	DRVSS	-0.3 to DRVDD + 0.3	V
AINP	AINN	AVSS - 0.3 to AVDD + 0.3	V
VREF	AVSS	-0.3 to AVDD + 0.3	V
REFSENSE	AVSS	-0.3 to AVDD + 0.3	V
REFTF, REFBF	AVSS	-0.3 to AVDD + 0.3	V
STBY	AVSS	-0.3 to AVDD + 0.3	V
CLAMP	AVSS	-0.3 to AVDD + 0.3	V
CLAMPIN	AVSS	-0.3 to AVDD + 0.3	V
PWRCON	AVSS	-0.3 to AVDD + 0.3	V
DFS	AVSS	-0.3 to AVDD + 0.3	V
3-STATE	AVSS	-0.3 to AVDD + 0.3	V
Junction Temperature		150	°C
Storage Temperature		+150	°C
Lead Temperature (10 s)		300	°C

Stresses above those listed under Absolute Maximum Ratings may cause permanent damage to the device. This is a stress rating only; functional operation of the device at these or any other conditions above those indicated in the operational section of this specification is not implied. Exposure to absolute maximum rating conditions for extended periods may affect device reliability.

THERMAL CHARACTERISTICS

28-Lead TSSOP

$J_A = 97.9^\circ\text{C/W}$

$J_C = 14.0^\circ\text{C/W}$

ESD CAUTION



ESD (electrostatic discharge) sensitive device. Charged devices and circuit boards can discharge without detection. Although this product features patented or proprietary protection circuitry, damage may occur on devices subjected to high energy ESD. Therefore, proper ESD precautions should be taken to avoid performance degradation or loss of functionality.

PIN CONFIGURATION AND FUNCTION DESCRIPTIONS

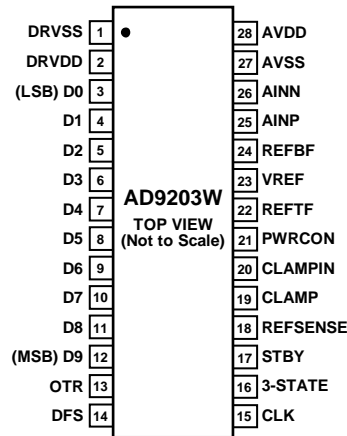
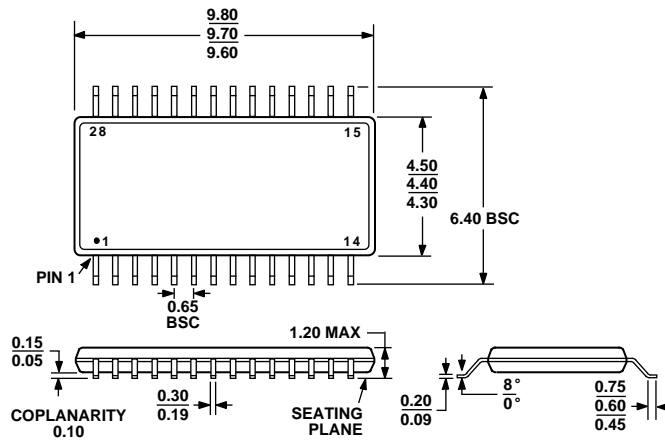

Figure 3. Pin Configuration

Table 3. Pin Function Descriptions

Pin	Name	Description
1	DRVSS	Digital Ground.
2	DRVDD	Digital Supply.
3	D0	Bit 0, Least Significant Bit.
4	D1	Bit 1.
5	D2	Bit 2.
6	D3	Bit 3.
7	D4	Bit 4.
8	D5	Bit 5.
9	D6	Bit 6.
10	D7	Bit 7.
11	D8	Bit 8.
12	D9	Bit 9, Most Significant Bit.
13	OTR	Out-of-Range Indicator.
14	DFS	Data Format Select HI: Twos Complement; LO: Straight Binary.
15	CLK	Clock Input.
16	3-STATE	HI: High Impedance State Output; LO: Active Digital Output Drives.
17	STBY	HI: Power-Down Mode; LO: Normal Operation.
18	REFSENSE	Reference Select.
19	CLAMP	HI: Enable Clamp; LO: Open Clamp.
20	CLAMPIN	Clamp Signal Input.
21	PWRCON	Power Control Input.
22	REFTF	Top Reference Decoupling.
23	VREF	Reference In/Out.
24	REFBF	Bottom Reference Decoupling.
25	AINP	Noninverting Analog Input.
26	AINN	Inverting Analog Input.
27	AVSS	Analog Ground.
28	AVDD	Analog Supply.

OUTLINE DIMENSIONS



COMPLIANT TO JEDEC STANDARDS MO-153-AE
 Figure 4. 28-Lead Thin Shrink Small Outline Package [TSSOP]
 (RU-28)
 Dimensions shown in millimeters

ORDERING GUIDE

Model ^{1,2}	Temperature Range	Package Description	Package Option
AD9203WARUZ	-40°C to +85°C	28-Lead Thin Shrink Small Outline [TSSOP]	RU-28
AD9203WARUZRL7	-40°C to +85°C	28-Lead Thin Shrink Small Outline [TSSOP]	RU-28

¹Z = RoHS Compliant Part.

²W = Qualified for Automotive Applications.

AUTOMOTIVE PRODUCTS

The AD9203W models are available with controlled manufacturing to support the quality and reliability requirements of automotive applications. Note that these automotive models may have specifications that differ from the commercial models; therefore, designers should review the Specifications section of this data sheet carefully. Only the automotive grade products shown are available for use in automotive applications. Contact your local Analog Devices account representative for specific product ordering information and to obtain the specific Automotive Reliability reports for these models.

NOTES

Looking for pricing, stock, or lifecycle information?

Click below to explore more details on WIN SOURCE:

 [View AD9203WARUZ on WIN SOURCE](#)

 [Analog Devices Inc. Information](#)

Optimize Your Supply Chain with WIN SOURCE Solutions

-  Global Sourcing Solution
-  Obsolete Management
-  Cost Control Management
-  Shortage Management
-  Alternative Solution
-  Excess Inventory Management