



**THE DATASHEET OF**  
**85304AG-01LFT**



## General Description

The 85304-01 is a low skew, high performance 1-to-5 Differential-to-3.3V LVPECL fanout buffer. The 85304-01 has two selectable clock inputs. The CLKx, nCLKx pairs can accept most standard differential input levels. The clock enable is internally synchronized to eliminate runt clock pulses on the outputs during asynchronous assertion/ deassertion of the clock enable pin.

Guaranteed output and part-to-part skew characteristics make the 85304-01 ideal for those applications demanding well defined performance and repeatability.

## Features

- Five 3.3V differential LVPECL output pairs
- Selectable differential CLKx, nCLKx input pairs
- CLKx, nCLKx input pairs can accept the following differential levels: LVDS, LVPECL, LVHSTL, SSTL and HCSL levels
- Maximum output frequency: 650MHz
- Translates any single-ended input signal to 3.3V LVPECL levels with resistor bias on nCLKx inputs
- Output skew: 35ps (maximum)
- Part-to-part skew: 150ps (maximum)
- Propagation delay: 2.1ns (maximum)
- Full 3.3V supply mode
- 0°C to 70°C ambient operating temperature

## Block Diagram

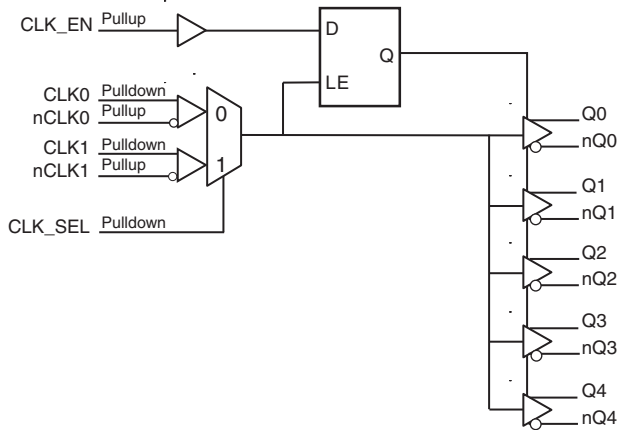

## Pin Assignment

Q0	1	20	Vcc
nQ0	2	19	CLK_EN
Q1	3	18	Vcc
nQ1	4	17	nCLK1
Q2	5	16	CLK1
nQ2	6	15	VEE
Q3	7	14	nCLK0
nQ3	8	13	CLK0
Q4	9	12	CLK_SEL
nQ4	10	11	Vcc

**85304-01**  
**20-Lead TSSOP**  
**6.5mm x 4.4mm x 0.925mm**  
**package body**  
**G Package**  
**Top View**

**Table 1. Pin Descriptions**

Number	Name	Type		Description
1, 2	Q0, nQ0	Output		Differential output pair. LVPECL interface levels.
3, 4	Q1, nQ1	Output		Differential output pair. LVPECL interface levels.
5, 6	Q2, nQ2	Output		Differential output pair. LVPECL interface levels.
7, 8	Q3, nQ3	Output		Differential output pair. LVPECL interface levels.
9, 10	Q4, nQ4	Output		Differential output pair. LVPECL interface levels.
11, 18, 20	V <sub>CC</sub>	Power		Power supply pins.
12	CLK_SEL	Input	Pulldown	Clock select input. When HIGH, selects CLK1, nCLK1 inputs. When LOW, selects CLK0, nCLK0 inputs. LVTTTL/LVCMOS interface levels.
13	CLK0	Input	Pulldown	Non-inverting differential clock input.
14	nCLK0	Input	Pullup	Inverting differential clock input.
15	V <sub>EE</sub>	Power		Negative supply pin.
16	CLK1	Input	Pulldown	Non-inverting differential clock input.
17	nCLK1	Input	Pullup	Inverting differential clock input.
19	CLK_EN	Input	Pullup	Synchronizing clock enable. When HIGH, clock outputs follow clock input. When LOW, Qx outputs are forced LOW, nQx outputs are forced HIGH. LVTTTL/LVCMOS interface levels.

NOTE: *Pullup and Pulldown* refer to internal input resistors. See Table 2, *Pin Characteristics*, for typical values.

**Table 2. Pin Characteristics**

Symbol	Parameter	Test Conditions	Minimum	Typical	Maximum	Units
C <sub>IN</sub>	Input Capacitance			4		pF
R <sub>PULLDOWN</sub>	Input Pulldown Resistor			51		kΩ
R <sub>PULLUP</sub>	Input Pullup Resistor			51		kΩ

## Function Tables

**Table 3A. Control Input Function Table**

Inputs			Outputs	
CLK_EN	CLK_SEL	Selected Source	Q0:Q4	nQ0:nQ4
0	0	CLK0, nCLK0	Disabled; LOW	Disabled; HIGH
0	1	CLK1, nCLK1	Disabled; LOW	Disabled; HIGH
1	0	CLK0, nCLK0	Enabled	Enabled
1	1	CLK1, nCLK1	Enabled	Enabled

After CLK\_EN switches, the clock outputs are disabled or enabled following a rising and falling input clock edge as shown in Figure 1. In the active mode, the state of the outputs are a function of the CLKx, nCLKx inputs as described in Table 3B.

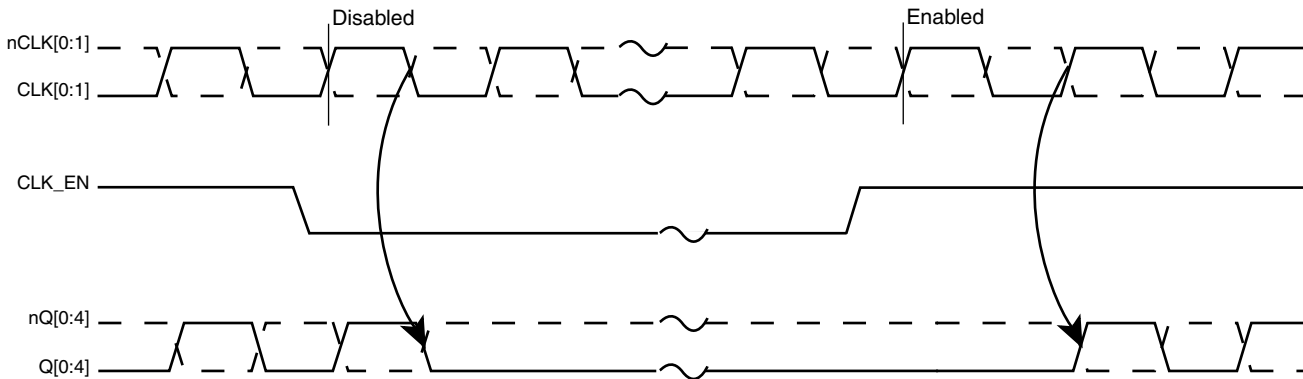
**Figure 1. CLK\_EN Timing Diagram**
**Table 3B. Clock Input Function Table**

Inputs		Outputs		Input to Output Mode	Polarity
CLK0 or CLK1	nCLK0 or nCLK1	Q[0:4]	nQ[0:4]		
0	1	LOW	HIGH	Differential to Differential	Non-Inverting
1	0	HIGH	LOW	Differential to Differential	Non-Inverting
0	Biased; NOTE 1	LOW	HIGH	Single-Ended to Differential	Non-Inverting
1	Biased; NOTE 1	HIGH	LOW	Single-Ended to Differential	Non-Inverting
Biased; NOTE 1	0	HIGH	LOW	Single-Ended to Differential	Inverting
Biased; NOTE 1	1	LOW	HIGH	Single-Ended to Differential	Inverting

NOTE 1: Please refer to the Application Information section, *Wiring the Differential Input to Accept Single-Ended Levels*.

## Absolute Maximum Ratings

NOTE: Stresses beyond those listed under *Absolute Maximum Ratings* may cause permanent damage to the device. These ratings are stress specifications only. Functional operation of the product at these conditions or any conditions beyond those listed in the *DC Characteristics* or *AC Characteristics* is not implied. Exposure to absolute maximum rating conditions for extended periods may affect product reliability.

Item	Rating
Supply Voltage, $V_{CC}$	4.6V
Inputs, $V_I$	-0.5V to $V_{CC} + 0.5V$
Outputs, $I_O$ Continuous Current Surge Current	50mA 100mA
Package Thermal Impedance, $\theta_{JA}$	73.2°C/W (0 lfpm)
Storage Temperature, $T_{STG}$	-65°C to 150°C

## DC Electrical Characteristics

**Table 4A. Power Supply DC Characteristics,  $V_{CC} = 3.3V \pm 5\%$ ,  $V_{EE} = 0V$ ,  $T_A = 0^\circ C$  to  $70^\circ C$**

Symbol	Parameter	Test Conditions	Minimum	Typical	Maximum	Units
$V_{CC}$	Power Supply Voltage		3.135	3.3	3.465	V
$I_{EE}$	Power Supply Current				55	mA

**Table 4B. LVCMOS/LVTTL DC Characteristics,  $V_{CC} = 3.3V \pm 5\%$ ,  $V_{EE} = 0V$ ,  $T_A = 0^\circ C$  to  $70^\circ C$**

Symbol	Parameter	Test Conditions	Minimum	Typical	Maximum	Units
$V_{IH}$	Input High Voltage		2		3.765	V
$V_{IL}$	Input Low Voltage		-0.3		0.8	V
$I_{IH}$	Input High Current	CLK_EN	$V_{CC} = V_{IN} = 3.465V$		5	$\mu A$
		CLK_SEL	$V_{CC} = V_{IN} = 3.465V$		150	$\mu A$
$I_{IL}$	Input Low Current	CLK_EN	$V_{CC} = 3.465V, V_{IN} = 0V$	-150		$\mu A$
		CLK_SEL	$V_{CC} = 3.465V, V_{IN} = 0V$	-5		$\mu A$

**Table 4C. Differential DC Characteristics,  $V_{CC} = 3.3V \pm 5\%$ ,  $V_{EE} = 0V$ ,  $T_A = 0^\circ C$  to  $70^\circ C$**

Symbol	Parameter	Test Conditions	Minimum	Typical	Maximum	Units
$I_{IH}$	Input High Current	nCLK0, nCLK1	$V_{CC} = V_{IN} = 3.465V$		5	$\mu A$
		CLK0, CLK1	$V_{CC} = V_{IN} = 3.465V$		150	$\mu A$
$I_{IL}$	Input Low Current	nCLK0, nCLK1	$V_{CC} = 3.465V, V_{IN} = 0V$	-150		$\mu A$
		CLK0, CLK1	$V_{CC} = 3.465V, V_{IN} = 0V$	-5		$\mu A$
$V_{PP}$	Peak-to-Peak Voltage; NOTE 1		0.15		1.3	V
$V_{CMR}$	Common Mode Input Voltage; NOTE 1, 2		$V_{EE} + 0.5$		$V_{CC} - 0.85$	V

NOTE 1:  $V_{IL}$  should not be less than -0.3V

NOTE 2: Common mode input voltage is defined as  $V_{IH}$ .

**Table 4D. LVPECL DC Characteristics,  $V_{CC} = 3.3V \pm 5\%$ ,  $V_{EE} = 0V$ ,  $T_A = 0^\circ C$  to  $70^\circ C$** 

Symbol	Parameter	Test Conditions	Minimum	Typical	Maximum	Units
$V_{OH}$	Output High Current; NOTE 1		$V_{CC} - 1.4$		$V_{CC} - 1.0$	$\mu A$
$V_{OL}$	Output Low Current; NOTE 1		$V_{CC} - 2.0$		$V_{CC} - 1.7$	$\mu A$
$V_{SWING}$	Peak-to-Peak Output Voltage Swing		0.6		0.85	V

NOTE 1: Outputs terminated with  $50\Omega$  to  $V_{CC} - 2V$ .

## AC Electrical Characteristics

**Table 5. AC Characteristics,  $V_{CC} = 3.3V \pm 5\%$ ,  $V_{EE} = 0V$ ,  $T_A = 0^\circ C$  to  $70^\circ C$** 

Symbol	Parameter	Test Conditions	Minimum	Typical	Maximum	Units
$f_{OUT}$	Output Frequency				650	MHz
$t_{PD}$	Propagation Delay; NOTE 1	$f \leq 650MHz$	1.0		2.1	ns
$t_{sk(o)}$	Output Skew; NOTE 2, 3				35	ps
$t_{sk(pp)}$	Part-to-Part Skew; NOTE 3, 4				150	ps
$t_R / t_F$	Output Rise/Fall Time	20% to 80% @ 50MHz	300		700	ps
odc	Output Duty Cycle		48	50	52	%

NOTE: Electrical parameters are guaranteed over the specified ambient operating temperature range, which is established when the device is mounted in a test socket with maintained transverse airflow greater than 500 lfm. The device will meet specifications after thermal equilibrium has been reached under these conditions.

NOTE: All parameters measured at 500MHz unless noted otherwise

NOTE: The cycle-to-cycle jitter on the input will equal the jitter on the output. The part does not add jitter.

NOTE 1: Measured from the differential input crossing point to the differential output crossing point. Measured at the output differential cross points.

NOTE 2: Defined as skew between outputs at the same supply voltage and with equal load conditions. Measured at the output differential cross points.

NOTE 3: This parameter is defined in accordance with JEDEC Standard 65.

NOTE 4: Defined as skew between outputs on different devices operating at the same supply voltage, same frequency, same temperature and with equal load conditions. Using the same type of inputs on each device, the outputs are measured at the differential cross points.

### Parameter Measurement Information

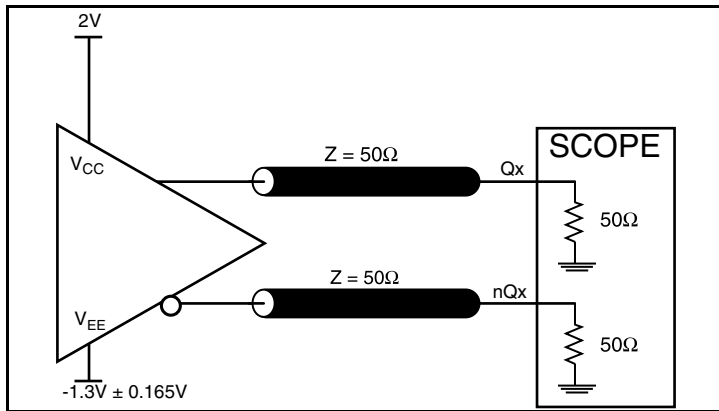

3.3V Output Load Test Circuit

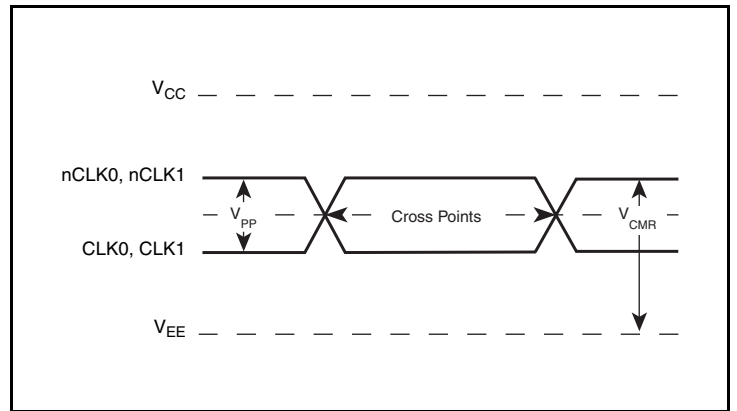

Differential Input Level

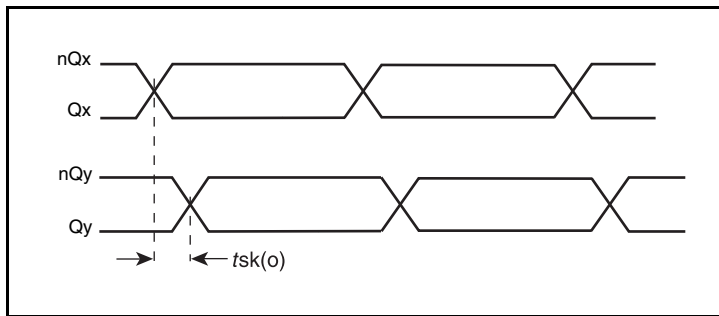

Output Skew

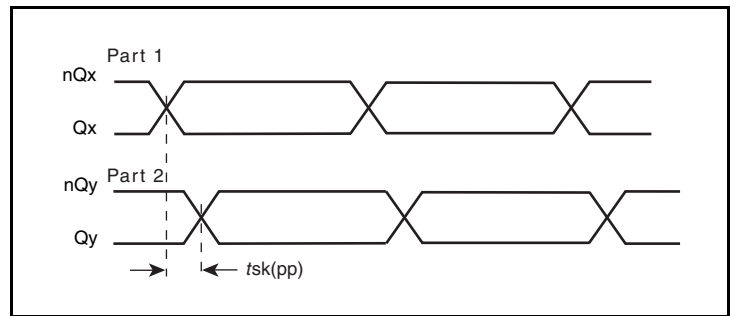

Part-to-Part Skew

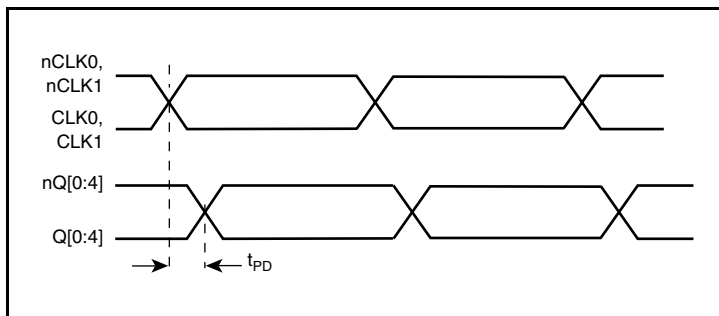

Output Duty Cycle/Pulse Width/Period

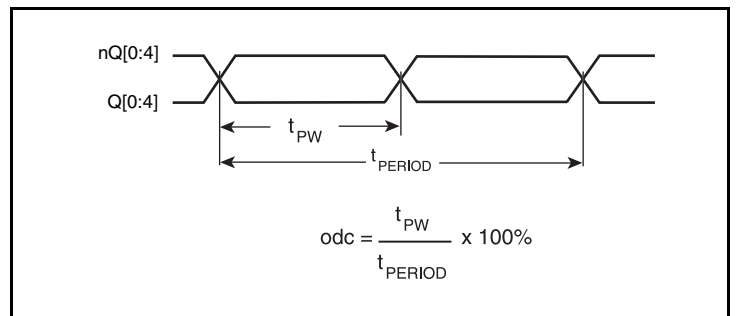

Output Duty Cycle/Pulse Width/Period

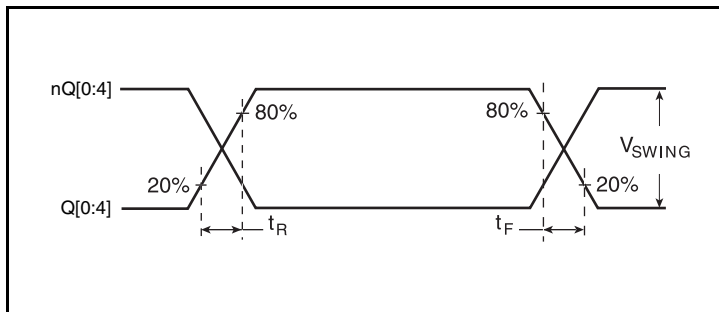

Output Rise/Fall Time

## Applications Information

### Wiring the Differential Input to Accept Single-Ended Levels

Figure 1 shows how a differential input can be wired to accept single ended levels. The reference voltage  $V_1 = V_{CC}/2$  is generated by the bias resistors R1 and R2. The bypass capacitor (C1) is used to help filter noise on the DC bias. This bias circuit should be located as close to the input pin as possible. The ratio of R1 and R2 might need to be adjusted to position the  $V_1$  in the center of the input voltage swing. For example, if the input clock swing is 2.5V and  $V_{CC} = 3.3V$ , R1 and R2 value should be adjusted to set  $V_1$  at 1.25V. The values below are for when both the single ended swing and  $V_{CC}$  are at the same voltage. This configuration requires that the sum of the output impedance of the driver ( $R_o$ ) and the series resistance ( $R_s$ ) equals the transmission line impedance. In addition, matched termination at the input will attenuate the signal in half. This can be done in one of two ways. First, R3 and R4 in parallel should equal the transmission line

impedance. For most 50Ω applications, R3 and R4 can be 100Ω. The values of the resistors can be increased to reduce the loading for slower and weaker LVCMOS driver. When using single-ended signaling, the noise rejection benefits of differential signaling are reduced. Even though the differential input can handle full rail LVCMOS signaling, it is recommended that the amplitude be reduced. The datasheet specifies a lower differential amplitude, however this only applies to differential signals. For single-ended applications, the swing can be larger, however  $V_{IL}$  cannot be less than -0.3V and  $V_{IH}$  cannot be more than  $V_{CC} + 0.3V$ . Though some of the recommended components might not be used, the pads should be placed in the layout. They can be utilized for debugging purposes. The datasheet specifications are characterized and guaranteed by using a differential signal.

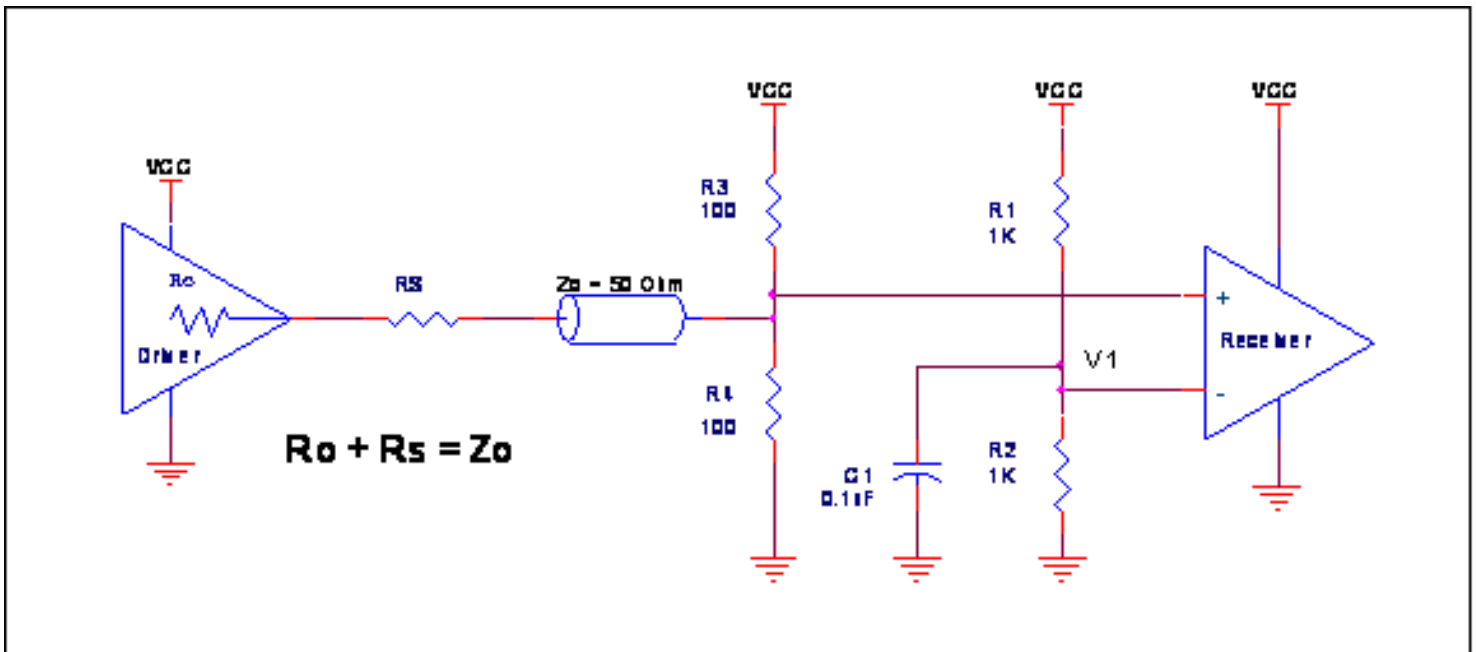
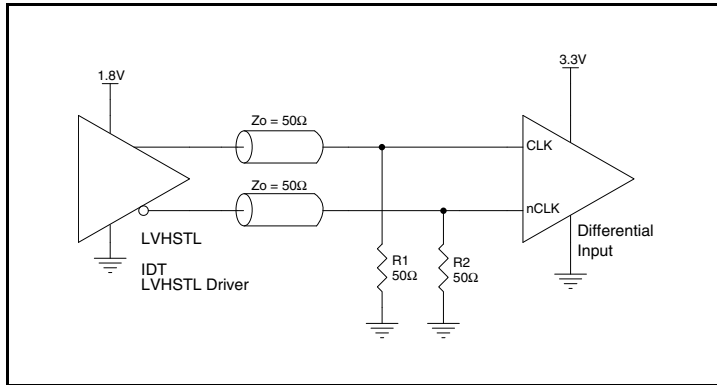

Figure 1. Recommended Schematic for Wiring a Differential Input to Accept Single-ended Levels

## Differential Clock Input Interface

The CLK /nCLK accepts LVDS, LVPECL, LVHSTL, SSTL, HCSL and other differential signals. Both  $V_{SWING}$  and  $V_{OH}$  must meet the  $V_{PP}$  and  $V_{CMR}$  input requirements. *Figures 2A to 2F* show interface examples for the CLK/nCLK input driven by the most common driver types. The input interfaces suggested here are examples only.

Please consult with the vendor of the driver component to confirm the driver termination requirements. For example, in Figure 2A, the input termination applies for IDT's open emitter LVHSTL drivers. If you are using an LVHSTL driver from another vendor, use their termination recommendation.



**Figure 2A. CLK/nCLK Input Driven by an IDT Open Emitter LVHSTL Driver**

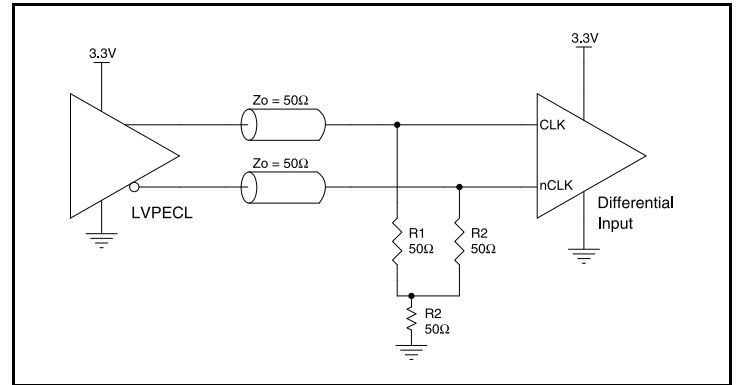

**Figure 2B. CLK/nCLK Input Driven by a 3.3V LVPECL Driver**

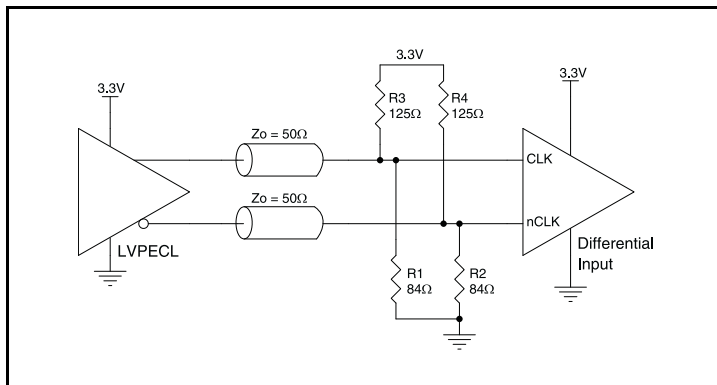

**Figure 2C. CLK/nCLK Input Driven by a 3.3V LVPECL Driver**

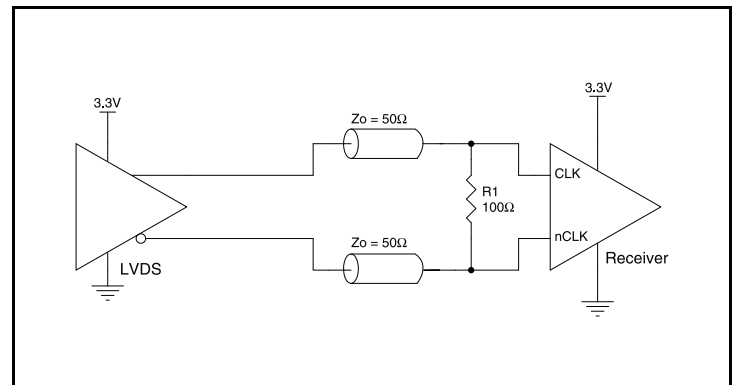

**Figure 2D. CLK/nCLK Input Driven by a 3.3V LVDS Driver**

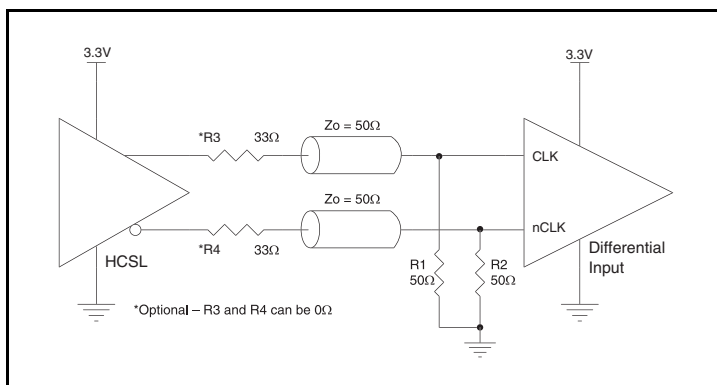

**Figure 2E. CLK/nCLK Input Driven by a 3.3V HCSL Driver**

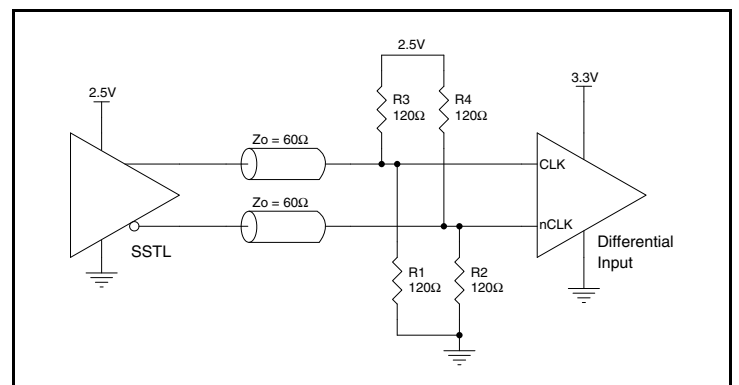

**Figure 2F. CLK/nCLK Input Driven by a 2.5V SSTL Driver**

## Recommendations for Unused Input and Output Pins

### Inputs:

#### LVC MOS Control Pins

All control pins have internal pullup or pulldown; additional resistance is not required but can be added for additional protection. A 1kΩ resistor can be used.

#### CLK/nCLK Inputs

For applications not requiring the use of the differential input, both CLK and nCLK can be left floating. Though not required, but for additional protection, a 1kΩ resistor can be tied from CLK to ground.

### Outputs:

#### LVPECL Outputs

All unused LVPECL output pairs can be left floating. We recommend that there is no trace attached. Both sides of the differential output pair should either be left floating or terminated.

## Termination for 3.3V LVPECL Outputs

The clock layout topology shown below is a typical termination for LVPECL outputs. The two different layouts mentioned are recommended only as guidelines.

The differential outputs are low impedance follower outputs that generate ECL/LVPECL compatible outputs. Therefore, terminating resistors (DC current path to ground) or current sources must be used for functionality. These outputs are designed to drive 50Ω

transmission lines. Matched impedance techniques should be used to maximize operating frequency and minimize signal distortion.

Figures 3A and 3B show two different layouts which are recommended only as guidelines. Other suitable clock layouts may exist and it would be recommended that the board designers simulate to guarantee compatibility across all printed circuit and clock component process variations.

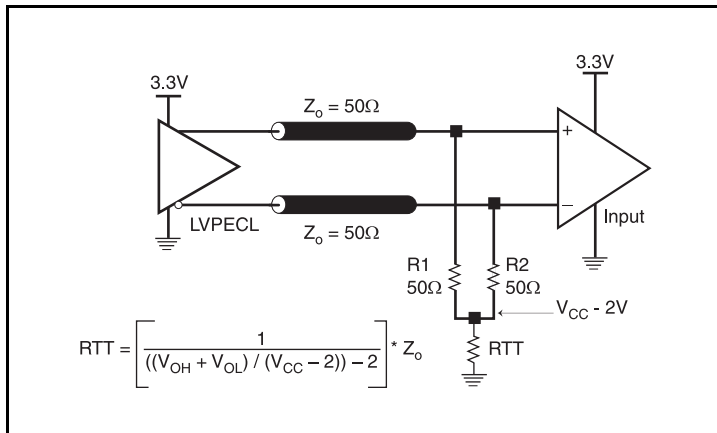

Figure 3A. 3.3V LVPECL Output Termination

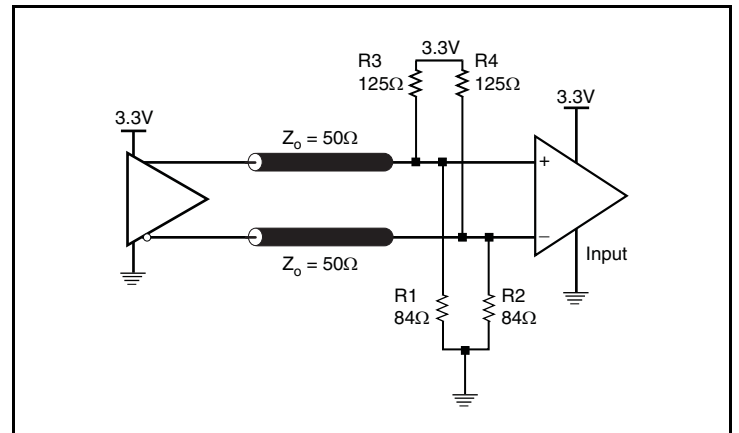

Figure 3B. 3.3V LVPECL Output Termination

## Power Considerations

This section provides information on power dissipation and junction temperature for the 85304-01. Equations and example calculations are also provided.

### 1. Power Dissipation.

The total power dissipation for the 85304-01 is the sum of the core power plus the output power dissipated due to loading. The following is the power dissipation for  $V_{CC} = 3.3V + 5\% = 3.465V$ , which gives worst case results.

NOTE: Please refer to Section 3 for details on calculating output power dissipated due to loading.

- Power (core)<sub>MAX</sub> =  $V_{CC\_MAX} * I_{EE\_MAX} = 3.465V * 55mA = \mathbf{190.57mW}$
- Power (outputs)<sub>MAX</sub> = **30.2mW/Loaded Output pair**  
If all outputs are loaded, the total power is  $5 * 30.2mW = \mathbf{151mW}$

**Total Power**<sub>MAX</sub> (3.465V, with all outputs switching) =  $190.57mW + 151mW = \mathbf{341.57mW}$

### 2. Junction Temperature.

Junction temperature,  $T_j$ , is the temperature at the junction of the bond wire and bond pad directly affects the reliability of the device. The maximum recommended junction temperature is 125°C. Limiting the internal transistor junction temperature,  $T_j$ , to 125°C ensures that the bond wire and bond pad temperature remains below 125°C.

The equation for  $T_j$  is as follows:  $T_j = \theta_{JA} * Pd\_total + T_A$

$T_j$  = Junction Temperature

$\theta_{JA}$  = Junction-to-Ambient Thermal Resistance

$Pd\_total$  = Total Device Power Dissipation (example calculation is in section 1 above)

$T_A$  = Ambient Temperature

In order to calculate junction temperature, the appropriate junction-to-ambient thermal resistance  $\theta_{JA}$  must be used. Assuming no air flow and a multi-layer board, the appropriate value is 73.2°C/W per Table 6 below.

Therefore,  $T_j$  for an ambient temperature of 70°C with all outputs switching is:

$$70^\circ\text{C} + 0.342\text{W} * 73.2^\circ\text{C/W} = 95^\circ\text{C}. \text{ This is well below the limit of } 125^\circ\text{C}.$$

This calculation is only an example.  $T_j$  will obviously vary depending on the number of loaded outputs, supply voltage, air flow and the type of board (multi-layer).

**Table 6. Thermal Resistance  $\theta_{JA}$  for 20 Lead TSSOP, Forced Convection**

$\theta_{JA}$ by Velocity			
Linear Feet per Minute	0	200	500
Single-Layer PCB, JEDEC Standard Test Boards	114.5°C/W	98.0°C/W	88.0°C/W
Multi-Layer PCB, JEDEC Standard Test Boards	73.2°C/W	66.6°C/W	63.5°C/W
NOTE: Most modern PCB designs use multi-layered boards. The data in the second row pertains to most designs.			

### 3. Calculations and Equations.

The purpose of this section is to derive the power dissipated into the load.

LVPECL output driver circuit and termination are shown in *Figure 4*.

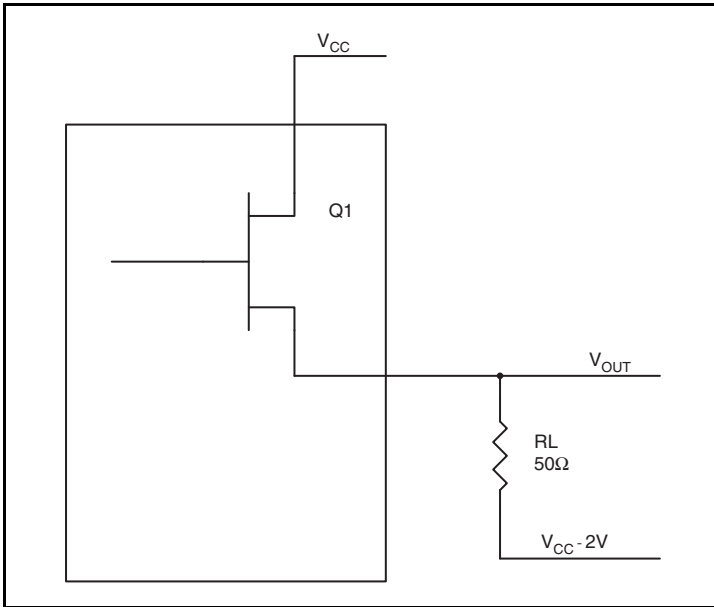

**Figure 4. LVPECL Driver Circuit and Termination**

To calculate output power dissipated due to loading, use the following equations which assume a 50Ω load, and a termination voltage of  $V_{CC} - 2V$ .

- For logic high,  $V_{OUT} = V_{OH\_MAX} = V_{CC\_MAX} - 1.0V$   
 $(V_{CC\_MAX} - V_{OH\_MAX}) = 1.0V$
- For logic low,  $V_{OUT} = V_{OL\_MAX} = V_{CC\_MAX} - 1.7V$   
 $(V_{CC\_MAX} - V_{OL\_MAX}) = 1.7V$

$Pd\_H$  is power dissipation when the output drives high.

$Pd\_L$  is the power dissipation when the output drives low.

$$Pd\_H = [(V_{OH\_MAX} - (V_{CC\_MAX} - 2V))/R_L] * (V_{CC\_MAX} - V_{OH\_MAX}) = [(2V - (V_{CC\_MAX} - V_{OH\_MAX}))/R_L] * (V_{CC\_MAX} - V_{OH\_MAX}) = [(2V - 1.0V)/50\Omega] * 1.0V = \mathbf{20mW}$$

$$Pd\_L = [(V_{OL\_MAX} - (V_{CC\_MAX} - 2V))/R_L] * (V_{CC\_MAX} - V_{OL\_MAX}) = [(2V - (V_{CC\_MAX} - V_{OL\_MAX}))/R_L] * (V_{CC\_MAX} - V_{OL\_MAX}) = [(2V - 1.7V)/50\Omega] * 1.7V = \mathbf{10.2mW}$$

$$\text{Total Power Dissipation per output pair} = Pd\_H + Pd\_L = \mathbf{30.2mW}$$

## Reliability Information

Table 7.  $\theta_{JA}$  vs. Air Flow Table for a 20 Lead TSSOP

$\theta_{JA}$ by Velocity			
Linear Feet per Minute	0	200	500
Single-Layer PCB, JEDEC Standard Test Boards	114.5°C/W	98.0°C/W	88.0°C/W
Multi-Layer PCB, JEDEC Standard Test Boards	73.2°C/W	66.6°C/W	63.5°C/W

NOTE: Most modern PCB designs use multi-layered boards. The data in the second row pertains to most designs.

## Transistor Count

The transistor count for 85304-01 is: 489

## Package Outline and Package Dimensions

Package Outline - G Suffix for 20 Lead TSSOP

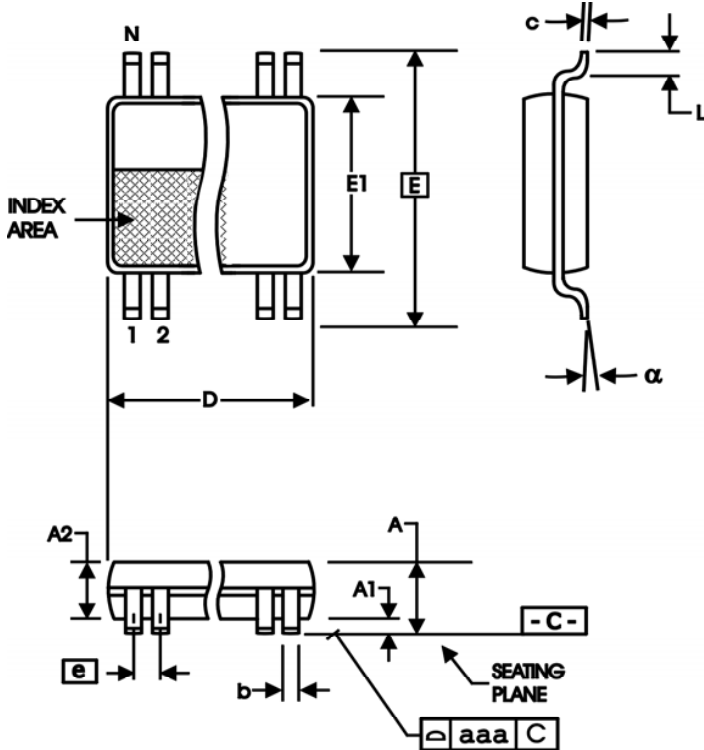

Table 8. Package Dimensions

All Dimensions in Millimeters		
Symbol	Minimum	Maximum
N	20	
A		1.20
A1	0.05	0.15
A2	0.80	1.05
b	0.19	0.30
c	0.09	0.20
D	6.40	6.60
E	6.40 Basic	
E1	4.30	4.50
e	0.65 Basic	
L	0.45	0.75
$\alpha$	0°	8°
aaa		0.10

Reference Document: JEDEC Publication 95, MO-153

## Ordering Information

Table 9. Ordering Information

Part/Order Number	Marking	Package	Shipping Packaging	Temperature
85304AG-01LF	ICS85304A01L	"Lead-Free" 20 Lead TSSOP	Tube	0°C to 70°C
85304AG-01LFT	ICS85304A01L	"Lead-Free" 20 Lead TSSOP	Tape & Reel	0°C to 70°C

## Revision History Sheet

Rev	Table	Page	Description of Change	Date
A	T4B T4D T5	4 5 5	$V_{CMR}$ values changed from 1.5V min. to 0.5V min.; $V_{DD}$ max. to $V_{CC} - 0.85V$ max. $V_{OH}$ values changed from 1.9 $\mu$ A min. to $V_{CC} - 1.4\mu$ A min.; 2.3 $\mu$ A max. to $V_{CC} - 1.0\mu$ A. $V_{OL}$ values changed from 1.2 $\mu$ A min. to $V_{CC} - 2.0\mu$ A; 1.6 $\mu$ A max. to $V_{CC} - 1.7\mu$ A max. Replaced $t_{PLH}$ and $t_{PHL}$ with $t_{PD}$ at the same values. Replaced $t_{PW}$ and values of $t_{CYCLE}/2 - 40$ min., $t_{CYCLE}/2$ typ., $t_{CYCLE}/2 + 40$ max. with odc at values of 48% min., 50% typ., 52% max.	5/14/01
B	T4D T5	5	LVPECL DC Characteristics Table - added $I_{IH}$ , $I_{IL}$ , $V_{PP}$ , and $V_{CMR}$ rows. AC Characteristics Table - $t_R$ and $t_F$ values changed from 275ps min to 300ps min; 650ps max. to 700ps max.	5/22/01
C	T4D	5	Differential DC Characteristics Table - $V_{CMR}$ values changed from $V_{CC} - 0.85V$ max. to $V_{CC}$ .	8/21/01
C		3	Revised Figure 1, CLK_EN Timing Diagram.	10/17/01
C		3	Revised Figure 1, CLK_EN Timing Diagram.	11/2/01
C	T3B	3	Revised Inputs heading from CLK or CLK, nPCLK or nPCLK to CLK or PCLK, nCLK or nPCLK.	12/28/01
C		8	Added <i>Termination for LVEPCL Output</i> section.	5/30/02
C		6 7	3.3V Output Load Test Circuit Diagram - corrected $V_{EE} = -1.3V \pm 0.135V$ to $V_{EE} = -1.3V \pm 0.165V$ . Updated Output Rise/Fall Time Diagram.	8/26/02
D	T2         T9	1 2 4 6 8 9 14	Added Lead-Free bullet in Features section. Pin Characteristics table - changed $C_{IN}$ 4pF max. to 4pF typical. Absolute Maximum Ratings, updated Outputs rating. Updated Parameter Measurement Information. Added <i>Differential Clock Input Interface</i> section. Added <i>LVPECL Clock Input Interface</i> section. Ordering Information table - added Lead Free part number.	6/17/04
E	    T9	 8 9 10 13	Per Document Errata, NEN-08-03, corrected name of PCLK/nPCLK to CLK1/nCLK1 and changed CLK/nCLK to CLK0/nCLK0 throughout the datasheet. Updated <i>Differential Clock Input Interface</i> section. Deleted <i>LVPECL Clock Input Interface</i> section. Added <i>Recommendations for Unused Input and Output Pins</i> section. Power Considerations - corrected Junction Temperature calculations. Ordering Information Table - corrected marking. Updated format throughout the datasheet.	6/20/08
E		3	Corrected Figure 1, CLK_EN Timing Diagram.	7/8/08
E	T4[A:D]  T5  T9	1 4 - 5 5 7 13	Features section - deleted package information DC Characteristic Tables - corrected table heading temperature from -40°C to 85°C to 0°C to 70°C. AC Characteristic Table - corrected table heading temperature from -40°C to 85°C to 0°C to 70°C. Added general note to table. Updated <i>Wiring the Differential Input to Accept Single-ended Levels</i> application note. Ordering Information Table - deleted non lead-free parts. Deleted Tape & Reel quantity from Shipping Packaging column.	12/19/12
E			Updated Header and Footer format.	12/2/15



Corporate Headquarters  
6024 Silver Creek Valley Road  
San Jose, CA 95138 USA  
[www.IDT.com](http://www.IDT.com)

Sales  
1-800-345-7015 or 408-284-8200  
Fax: 408-284-2775  
[www.IDT.com/go/sales](http://www.IDT.com/go/sales)

Tech Support  
[www.idt.com/go/support](http://www.idt.com/go/support)

DISCLAIMER Integrated Device Technology, Inc. (IDT) reserves the right to modify the products and/or specifications described herein at any time, without notice, at IDT's sole discretion. Performance specifications and operating parameters of the described products are determined in an independent state and are not guaranteed to perform the same way when installed in customer products. The information contained herein is provided without representation or warranty of any kind, whether express or implied, including, but not limited to, the suitability of IDT's products for any particular purpose, an implied warranty of merchantability, or non-infringement of the intellectual property rights of others. This document is presented only as a guide and does not convey any license under intellectual property rights of IDT or any third parties.

IDT's products are not intended for use in applications involving extreme environmental conditions or in life support systems or similar devices where the failure or malfunction of an IDT product can be reasonably expected to significantly affect the health or safety of users. Anyone using an IDT product in such a manner does so at their own risk, absent an express, written agreement by IDT.

Integrated Device Technology, IDT and the IDT logo are trademarks or registered trademarks of IDT and its subsidiaries in the United States and other countries. Other trademarks used herein are the property of IDT or their respective third party owners.

For datasheet type definitions and a glossary of common terms, visit [www.idt.com/go/glossary](http://www.idt.com/go/glossary).

Copyright ©2015 Integrated Device Technology, Inc. All rights reserved.

## Looking for pricing, stock, or lifecycle information?

Click below to explore more details on WIN SOURCE:

- ⊖ [View 85304AG-01LFT on WIN SOURCE](#)
- ⊖ [IDT, Integrated Device Technology Inc Information](#)

## Optimize Your Supply Chain with WIN SOURCE Solutions

- ✓ Global Sourcing Solution
- ✓ Obsolete Management
- ✓ Cost Control Management
- ✓ Shortage Management
- ✓ Alternative Solution
- ✓ Excess Inventory Management