



THE DATASHEET OF LM431BCM/NOPB



LM431 Adjustable Precision Zener Shunt Regulator

1 Features

- Average Temperature Coefficient 50 ppm/°C
- Temperature Compensated for Operation Over the Full Temperature Range
- Programmable Output Voltage
- Fast Turnon Response
- Low-Output Noise
- Low-Dynamic Output Impedance
- Available in Space-Saving SOIC-8, SOT-23, and TO-92 Packages

2 Applications

- Adjustable Voltage or Current Linear and Switching Power Supplies
- Voltage Monitoring
- Current Source and Sink Circuits
- Circuits Requiring Precision References
- Zener Diode Replacements

3 Description

The LM431 is a 3-terminal adjustable shunt regulator with ensured temperature stability over the entire temperature range of operation. The output voltage may be set at any level greater than 2.5 V (V_{REF}) up to 36 V merely by selecting two external resistors that act as a voltage divided network. Due to the sharp turnon characteristics this device is an excellent replacement for many Zener diode applications.

The LM431 is available in space-saving SOIC-8, SOT-23, and TO-92 packages.

Device Information⁽¹⁾

PART NUMBER	PACKAGE	BODY SIZE (NOM)
LM431	SOIC (8)	4.90 mm × 3.91 mm
	SOT-23 (3)	2.92 mm × 1.30 mm
	TO-92 (3)	4.30 mm × 4.30 mm

(1) For all available packages, see the orderable addendum at the end of the data sheet.

LM431 Symbol

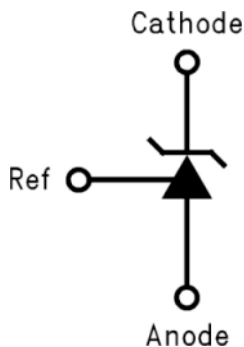

Functional Block Diagram

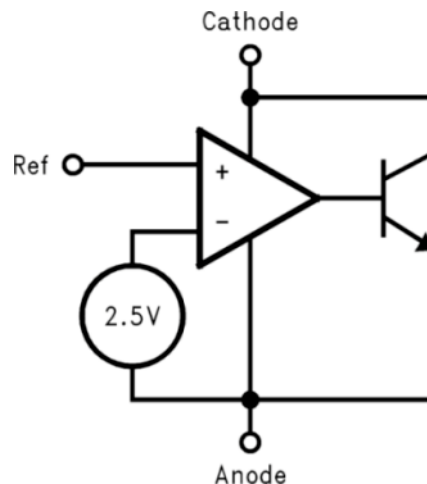

Table of Contents

1 Features	1	8.3 Feature Description	10
2 Applications	1	8.4 Device Functional Modes	11
3 Description	1	9 Application and Implementation	12
4 Revision History	2	9.1 Application Information	12
5 Pin Configuration and Functions	3	9.2 Typical Applications	13
6 Specifications	4	10 Power Supply Recommendations	19
6.1 Absolute Maximum Ratings	4	11 Layout	19
6.2 ESD Ratings	4	11.1 Layout Guidelines	19
6.3 Recommended Operating Conditions	4	11.2 Layout Example	19
6.4 Thermal Information	4	12 Device and Documentation Support	20
6.5 Electrical Characteristics	5	12.1 Community Resources	20
6.6 Typical Characteristics	7	12.2 Trademarks	20
7 Parameter Measurement Information	7	12.3 Electrostatic Discharge Caution	20
8 Detailed Description	10	12.4 Glossary	20
8.1 Overview	10	13 Mechanical, Packaging, and Orderable Information	20
8.2 Functional Block Diagram	10		

4 Revision History

NOTE: Page numbers for previous revisions may differ from page numbers in the current version.

Changes from Revision G (March 2013) to Revision H	Page
<ul style="list-style-type: none"> Added <i>ESD Ratings</i> table, <i>Feature Description</i> section, <i>Device Functional Modes</i>, <i>Application and Implementation</i> section, <i>Power Supply Recommendations</i> section, <i>Layout</i> section, <i>Device and Documentation Support</i> section, and <i>Mechanical, Packaging, and Orderable Information</i> section 	1

Changes from Revision F (April 2013) to Revision G	Page
<ul style="list-style-type: none"> Changed layout of National Data Sheet to TI format 	18

5 Pin Configuration and Functions

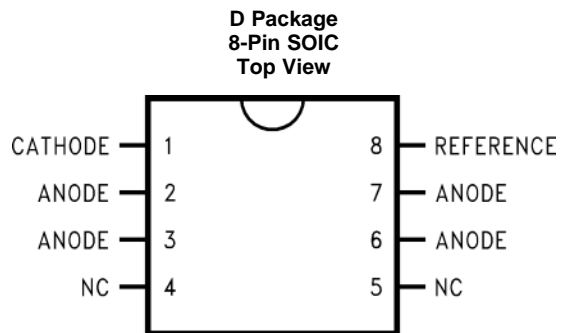

Note: NC = Not internally connected.

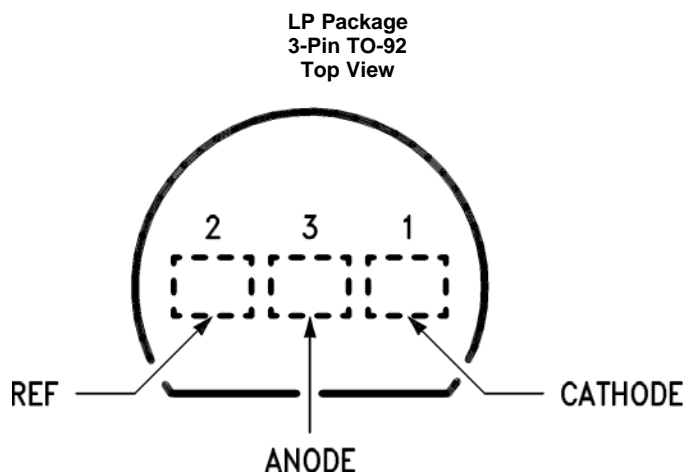
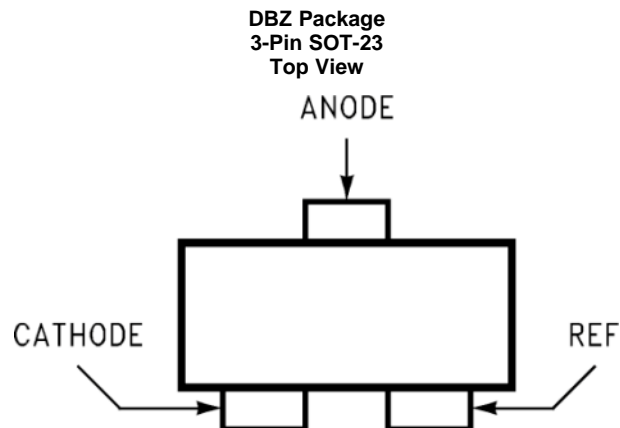

Pin Functions

NAME	PIN			I/O	DESCRIPTION
	SOIC	SOT-23	TO-92		
Anode	2, 3, 6, 7	3	3	O	Anode pin, normally grounded
Cathode	1	1	1	I/O	Shunt current/output voltage
NC	4, 5	—	—	—	No connect
Reference	8	2	2	I	Reference pin for adjustable output voltage

6 Specifications

6.1 Absolute Maximum Ratings

 over operating free-air temperature range (unless otherwise noted)⁽¹⁾⁽²⁾

		MIN	MAX	UNIT
Cathode voltage		37		V
Reference voltage		-0.5		V
Continuous cathode current		-10	150	mA
Reference input current		10		mA
Internal power dissipation ⁽³⁾⁽⁴⁾	TO-92 package	0.78		W
	SOIC package	0.81		W
	SOT-23 package	0.28		W
Operating temperature	Industrial (LM431xI)	-40	85	°C
	Commercial (LM431xC)	0	70	°C
Storage temperature		-65	150	°C

- (1) Stresses beyond those listed under *Absolute Maximum Ratings* may cause permanent damage to the device. These are stress ratings only, which do not imply functional operation of the device at these or any other conditions beyond those indicated under *Recommended Operating Conditions*. Exposure to absolute-maximum-rated conditions for extended periods may affect device reliability.
- (2) If Military/Aerospace specified devices are required, please contact the TI Sales Office/ Distributors for availability and specifications.
- (3) $T_{J\text{Max}} = 150^{\circ}\text{C}$.
- (4) Ratings apply to ambient temperature at 25°C. Above this temperature, derate the TO-92 at 6.2 mW/°C, the SOIC at 6.5 mW/°C, the SOT-23 at 2.2 mW/°C.

6.2 ESD Ratings

			VALUE	UNIT
V_{ESD}	Electrostatic discharge	Human-body model (HBM), per ANSI/ESDA/JEDEC JS-001 ⁽¹⁾	±2500	V

- (1) JEDEC document JEP155 states that 500-V HBM allows safe manufacturing with a standard ESD control process.

6.3 Recommended Operating Conditions

over operating free-air temperature range (unless otherwise noted)

		MIN	MAX	UNIT
Cathode voltage		V_{REF}	37	V
Cathode current		1	100	mA

6.4 Thermal Information

THERMAL METRIC ⁽¹⁾		LM431			UNIT
		D (SOIC)	DBZ (SOT-23)	LP (TO-92)	
		8 PINS	3 PINS	3 PINS	
$R_{\theta\text{JA}}$	Junction-to-ambient thermal resistance	126.9	267.7	162.4	°C/W
$R_{\theta\text{JC(top)}}$	Junction-to-case (top) thermal resistance	72.2	138.3	85.8	°C/W
$R_{\theta\text{JB}}$	Junction-to-board thermal resistance	67.5	61	—	°C/W
Ψ_{JT}	Junction-to-top characterization parameter	21.1	21.5	29.4	°C/W
Ψ_{JB}	Junction-to-board characterization parameter	67	60.1	141.5	°C/W
$R_{\theta\text{JC(bot)}}$	Junction-to-case (bottom) thermal resistance	—	—	—	°C/W

- (1) For more information about traditional and new thermal metrics, see the *Semiconductor and IC Package Thermal Metrics* application report, [SPRA953](#).

6.5 Electrical Characteristics

 $T_A = 25^\circ\text{C}$ unless otherwise specified

PARAMETER		TEST CONDITIONS		MIN	TYP	MAX	UNIT
V_{REF}	Reference voltage	$V_Z = V_{REF}$, $I_I = 10\text{ mA}$ LM431A (Figure 6)		2.44	2.495	2.55	V
		$V_Z = V_{REF}$, $I_I = 10\text{ mA}$ LM431B (Figure 6)		2.47	2.495	2.52	
		$V_Z = V_{REF}$, $I_I = 10\text{ mA}$ LM431C (Figure 6)		2.485	2.5	2.51	
V_{DEV}	Deviation of reference input voltage overtemperature ⁽¹⁾	$V_Z = V_{REF}$, $I_I = 10\text{ mA}$, $T_A = \text{full range}$ (Figure 6)			8	17	mV
$\frac{\Delta V_{REF}}{\Delta V_Z}$	Ratio of the change in reference voltage to the change in cathode voltage	$I_Z = 10\text{ mA}$ (Figure 7)	V_Z from V_{REF} to 10 V		-1.4	-2.7	mV/V
			V_Z from 10 V to 36 V		-1	-2	
I_{REF}	Reference input current	$R_1 = 10\text{ k}\Omega$, $R_2 = \infty$, $I_I = 10\text{ mA}$ (Figure 7)			2	4	μA
αI_{REF}	Deviation of reference input current overtemperature	$R_1 = 10\text{ k}\Omega$, $R_2 = \infty$, $I_I = 10\text{ mA}$, $T_A = \text{full range}$ (Figure 7)			0.4	1.2	μA
$I_{Z(MIN)}$	Minimum cathode current for regulation	$V_Z = V_{REF}$ (Figure 6)			0.4	1	mA
$I_{Z(OFF)}$	OFF-state current	$V_Z = 36\text{ V}$, $V_{REF} = 0\text{ V}$ (Figure 8)			0.3	1	μA

- (1) Deviation of reference input voltage, V_{DEV} , is defined as the maximum variation of the reference input voltage over the full temperature range.



The average temperature coefficient of the reference input voltage, αV_{REF} , is defined as:

$$\alpha V_{REF} \frac{\text{ppm}}{^\circ\text{C}} = \frac{\pm \left[\frac{V_{MAX} - V_{MIN}}{V_{REF}(\text{at } 25^\circ\text{C})} \right] 10^6}{T_2 - T_1} = \frac{\pm \left[\frac{V_{DEV}}{V_{REF}(\text{at } 25^\circ\text{C})} \right] 10^6}{T_2 - T_1}$$

Where:

$T_2 - T_1 = \text{full temperature change (0–70}^\circ\text{C)}$.

V_{REF} can be positive or negative depending on whether the slope is positive or negative.

Example: $V_{DEV} = 8\text{ mV}$, $V_{REF} = 2495\text{ mV}$, $T_2 - T_1 = 70^\circ\text{C}$, slope is positive.

$$\alpha V_{REF} = \frac{\left[\frac{8.0\text{ mV}}{2495\text{ mV}} \right] 10^6}{70^\circ\text{C}} = +46\text{ ppm}/^\circ\text{C}$$

Electrical Characteristics (continued)
 $T_A = 25^\circ\text{C}$ unless otherwise specified

PARAMETER	TEST CONDITIONS	MIN	TYP	MAX	UNIT
r_Z Dynamic output impedance ⁽²⁾	$V_Z = V_{REF}$, LM431A, Frequency = 0 Hz (Figure 6)			0.75	Ω
	$V_Z = V_{REF}$, LM431B, LM431C Frequency = 0 Hz (Figure 6)			0.5	

 (2) The dynamic output impedance, r_Z , is defined as:

$$r_Z = \frac{\Delta V_Z}{\Delta I_Z}$$

 When the device is programmed with two external resistors, R1 and R2, (see Figure 7), the dynamic output impedance of the overall circuit, r_Z , is defined as:

$$r_Z = \frac{\Delta V_Z}{\Delta I_Z} \cong \left[r_Z \left(1 + \frac{R1}{R2} \right) \right]$$

6.6 Typical Characteristics

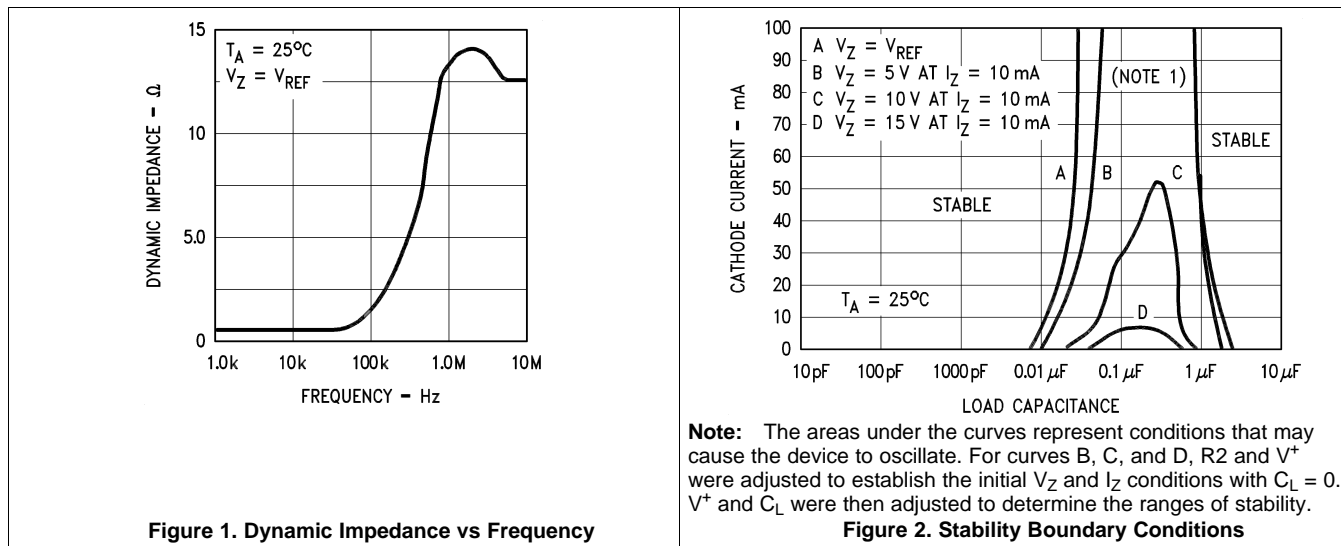

7 Parameter Measurement Information



Figure 3. Test Circuit for Dynamic Impedance vs Frequency Curve

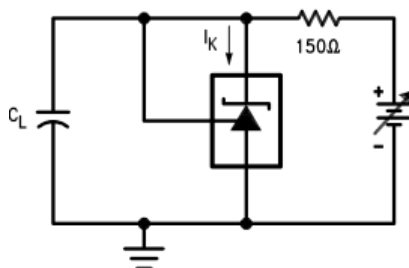

Figure 4. Test Circuit for Curve A Above

Parameter Measurement Information (continued)

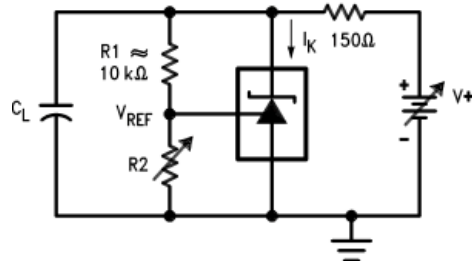

Figure 5. Test Circuit for Curves B, C and D Above

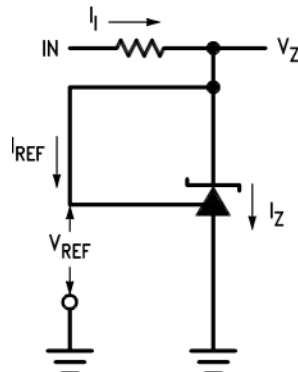

Figure 6. Test Circuit for $V_Z = V_{REF}$



Note: $V_Z = V_{REF} (1 + R1/R2) + I_{REF} \times R1$

Figure 7. Test Circuit for $V_Z > V_{REF}$

Parameter Measurement Information (continued)

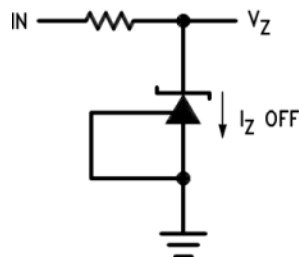

Figure 8. Test Circuit for OFF-State Current

8 Detailed Description

8.1 Overview

The LM431 is an adjustable precision shunt voltage regulator with ensured temperature stability over the entire temperature range. The part has three different packages available to meet small footprint requirements, and is available in three different tolerance grades.

8.2 Functional Block Diagram

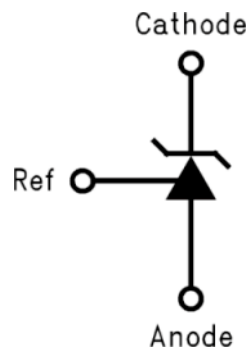

Figure 9. LM431 Symbol



Figure 10. LM431 Block Diagram

8.3 Feature Description

The LM431 is a precision Zener diode. The part requires a small quiescent current for regulation, and regulates the output voltage by shunting more or less current to ground, depending on input voltage and load. The only external component requirement is a resistor between the cathode and the input voltage to set the input current. An external capacitor can be used on the input or output, but is not required.

Feature Description (continued)

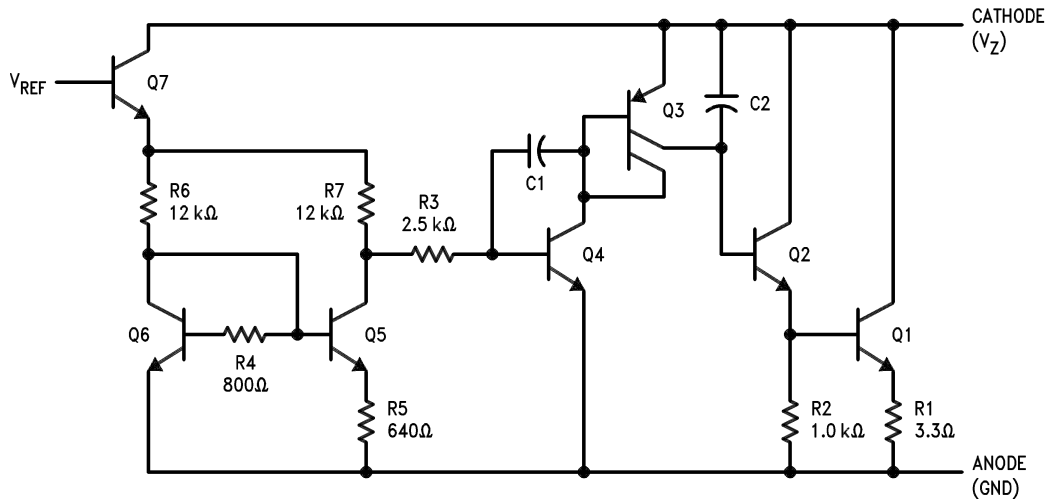

Figure 11. Equivalent Circuit

8.4 Device Functional Modes

The LM431 is most commonly operated in closed-loop mode, where the reference node is tied to the output voltage via a resistor divider. The output voltage remains in regulation as long as I_z is between 1 mA and 100 mA. The part can also be used in open-loop mode to act as a comparator, driving the feedback node from another voltage source.

9 Application and Implementation

NOTE

Information in the following applications sections is not part of the TI component specification, and TI does not warrant its accuracy or completeness. TI's customers are responsible for determining suitability of components for their purposes. Customers must validate and test their design implementation to confirm system functionality.

9.1 Application Information

The LM431 is an adjustable precision shunt voltage regulator with ensured temperature stability over the entire temperature range. For space critical applications, the LM431 is available in space saving SOIC-8, SOT-23 and TO-92 packages. The minimum operating current is 1 mA while the maximum operating current is 100 mA.

The typical thermal hysteresis specification is defined as the change in 25°C voltage measured after thermal cycling. The device is thermal cycled to temperature 0°C and then measured at 25°C. Next the device is thermal cycled to temperature 70°C and again measured at 25°C. The resulting V_{OUT} delta shift between the 25°C measurements is thermal hysteresis. Thermal hysteresis is common in precision references and is induced by thermal-mechanical package stress. Changes in environmental storage temperature, operating temperature and board mounting temperature are all factors that can contribute to thermal hysteresis.

In a conventional shunt regulator application ([Figure 12](#)), an external series resistor (R_S) is connected between the supply voltage and the LM431 cathode pin. R_S determines the current that flows through the load (I_{LOAD}) and the LM431 (I_Z). Since load current and supply voltage may vary, R_S must be small enough to supply at least the minimum acceptable I_Z to the LM431 even when the supply voltage is at its minimum and the load current is at its maximum value. When the supply voltage is at its maximum and I_{LOAD} is at its minimum, R_S must be large enough so that the current flowing through the LM431 is less than 100 mA.

R_S must be selected based on the supply voltage, (V₊), the desired load and operating current, (I_{LOAD} and I_Z), and the output voltage, see [Equation 1](#).

$$R_S = \frac{V_+ - V_O}{I_{LOAD} + I_Z} \quad (1)$$

The LM431 output voltage can be adjusted to any value in the range of 2.5 V through 37 V. It is a function of the internal reference voltage (V_{REF}) and the ratio of the external feedback resistors as shown in [Figure 12](#). The output voltage is found using [Equation 2](#).

$$V_O = V_{REF} * (1 + R_1/R_2)$$

where

- V_O is the output voltage (also, cathode voltage, V_Z). The actual value of the internal V_{REF} is a function of V_Z. (2)

The corrected V_{REF} is determined by [Equation 3](#):

$$V_{REF} = \Delta V_Z * (\Delta V_{REF}/\Delta V_Z) + V_Y$$

where

- V_Y = 2.5 V and ΔV_Z = (V_Z – V_Y)
- ΔV_{REF}/ΔV_Z is found in the [Electrical Characteristics](#) and is typically –1.4 mV/V for V_Z raging from V_{REF} to 10 V and –1 mV/V for V_Z raging from 10 V to 36 V. (3)

9.2 Typical Applications

9.2.1 Shunt Regulator



$$V_O \approx \left(1 + \frac{R_1}{R_2} \right) V_{REF}$$

Figure 12. Shunt Regulator

9.2.1.1 Design Requirements

Design a shunt regulator with the following requirements:

- $V_+ > V_O$
- $V_O = 5\text{ V}$

Select R_S (a resistor between V_+ and V_O) such that: $1\text{ mA} < I_Z < 100\text{ mA}$

9.2.1.2 Detailed Design Procedure

The resistor R_S must be selected such that current I_Z remains in the operational region of the part for the entire V_+ range and load current range. The two extremes to consider are V_+ at its minimum, and the load at its maximum, where R_S must be small enough for I_Z to remain above 1 mA. The other extreme is V_+ at its maximum, and the load at its minimum, where R_S must be large enough to maintain $I_Z < 100\text{ mA}$. If unsure, try using $1\text{ mA} \leq I_Z \leq 10\text{ mA}$ as a starting point; just remember the value of I_Z varies with input voltage and load.

Use Equation 4 and Equation 5 to set R_S between R_{S_MIN} and R_{S_MAX} .

$$R_{S_MIN} = \frac{V_{+_MAX} - V_O}{I_{LOAD_MIN} + I_{Z_MAX}} \quad (4)$$

$$R_{S_MAX} = \frac{V_{+_MIN} - V_O}{I_{LOAD_MAX} + I_{Z_MIN}} \quad (5)$$

Set feedback resistors R_1 and R_2 for a resistor divider based on Equation 2 and reproduced in Equation 6

$$V_O = V_{REF} * (1 + R_1/R_2) \quad (6)$$

So, for a 5-V output voltage, V_O , and V_{REF} of 2.5 V, simple calculation yields $R_1/R_2 = 1$. Based on this, select $R_1 = 1\text{ k}\Omega$ and $R_2 = 1\text{ k}\Omega$.

Typical Applications (continued)

9.2.1.3 Application Curves



9.2.2 Other Applications

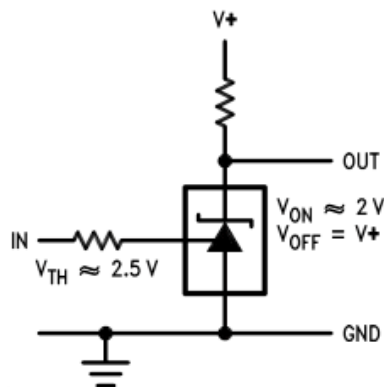
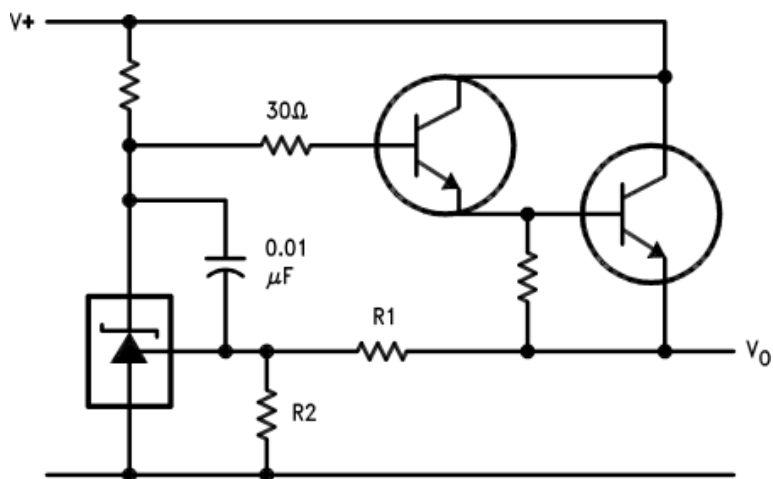

Figure 16. Single Supply Comparator With Temperature Compensated Threshold

Typical Applications (continued)



$$V_O \approx \left(1 + \frac{R_1}{R_2} \right) V_{REF}$$

Figure 17. Series Regulator

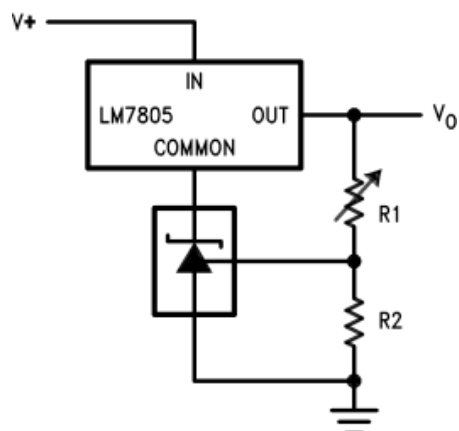

$$V_O = \left(1 + \frac{R_1}{R_2} \right) V_{REF}$$

$$V_{O \text{ MIN}} = V_{REF} + 5V$$

Figure 18. Output Control of a Three Terminal Fixed Regulator

Typical Applications (continued)

$$V_O \approx \left(1 + \frac{R_1}{R_2} \right) V_{REF}$$

Figure 19. Higher Current Shunt Regulator

$$V_{LIMIT} \approx \left(1 + \frac{R_1}{R_2} \right) V_{REF}$$

Figure 20. Crow Bar

Typical Applications (continued)



$$\text{LOW LIMIT} \approx V_{\text{REF}} \left(1 + \frac{R1B}{R2B} \right) + V_{\text{BE}}$$

$$\text{HIGH LIMIT} \approx V_{\text{REF}} \left(1 + \frac{R1A}{R2A} \right)$$

Figure 21. Over Voltage and Under Voltage Protection Circuit



$$\text{LOW LIMIT} \approx V_{\text{REF}} \left(1 + \frac{R1B}{R2B} \right) \quad \text{LED ON WHEN} \quad \text{LOW LIMIT} < V^+ < \text{HIGH LIMIT}$$

$$\text{HIGH LIMIT} \approx V_{\text{REF}} \left(1 + \frac{R1A}{R2A} \right)$$

Figure 22. Voltage Monitor

Typical Applications (continued)

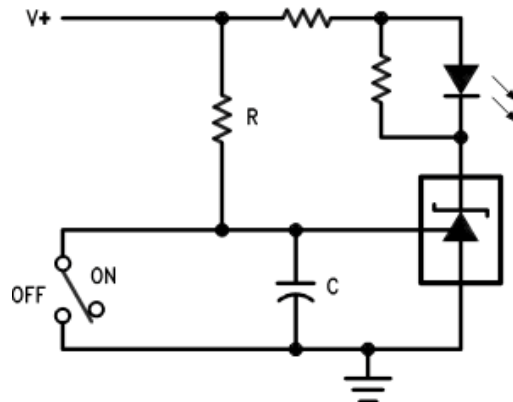

$$\text{DELAY} = R \cdot C \cdot \ln \frac{V+}{(V+) - V_{\text{REF}}}$$

Figure 23. Delay Timer



$$I_o = \frac{V_{\text{REF}}}{R_{\text{CL}}}$$

Figure 24. Current Limiter or Current Source



Figure 25. Constant Current Sink

10 Power Supply Recommendations

While a bypass capacitor is not required on the input voltage line, TI recommends reducing noise on the input which could affect the output. TI recommends a 0.1- μ F ceramic capacitor or larger.

11 Layout

11.1 Layout Guidelines

Place external components as close to the device as possible. Place R_S close to the cathode, as well as the input bypass capacitor, if used. Keep feedback resistor close the device whenever possible.

11.2 Layout Example

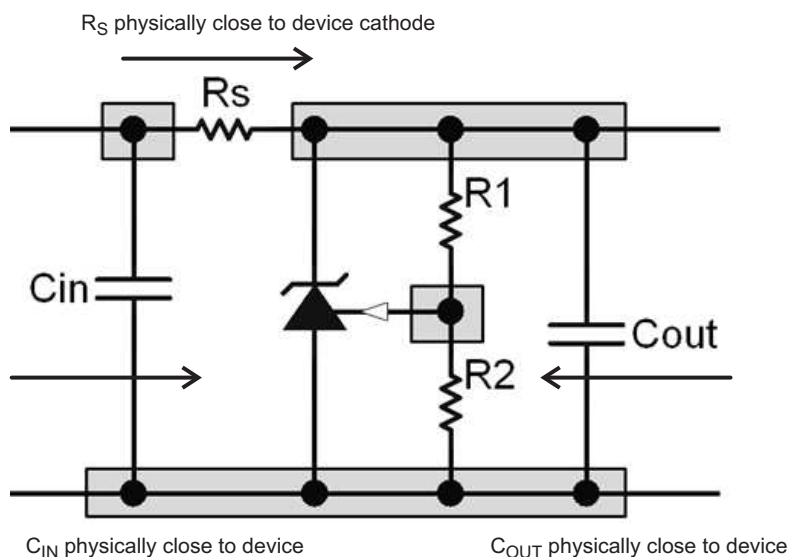

Figure 26. LM431 Layout Recommendation

12 Device and Documentation Support

12.1 Community Resources

The following links connect to TI community resources. Linked contents are provided "AS IS" by the respective contributors. They do not constitute TI specifications and do not necessarily reflect TI's views; see TI's [Terms of Use](#).

TI E2E™ Online Community *TI's Engineer-to-Engineer (E2E) Community*. Created to foster collaboration among engineers. At e2e.ti.com, you can ask questions, share knowledge, explore ideas and help solve problems with fellow engineers.

Design Support *TI's Design Support* Quickly find helpful E2E forums along with design support tools and contact information for technical support.

12.2 Trademarks

E2E is a trademark of Texas Instruments.
All other trademarks are the property of their respective owners.

12.3 Electrostatic Discharge Caution



These devices have limited built-in ESD protection. The leads should be shorted together or the device placed in conductive foam during storage or handling to prevent electrostatic damage to the MOS gates.

12.4 Glossary

[SLYZ022](#) — *TI Glossary*.

This glossary lists and explains terms, acronyms, and definitions.



13 Mechanical, Packaging, and Orderable Information

The following pages include mechanical, packaging, and orderable information. This information is the most current data available for the designated devices. This data is subject to change without notice and revision of this document. For browser-based versions of this data sheet, refer to the left-hand navigation.

PACKAGING INFORMATION

Orderable Device	Status (1)	Package Type	Package Drawing	Pins	Package Qty	Eco Plan (2)	Lead/Ball Finish (6)	MSL Peak Temp (3)	Op Temp (°C)	Device Marking (4/5)	Samples
LM431ACM	NRND	SOIC	D	8	95	TBD	Call TI	Call TI	0 to 70	LM431 ACM	
LM431ACM/NOPB	ACTIVE	SOIC	D	8	95	Green (RoHS & no Sb/Br)	CU SN	Level-1-260C-UNLIM	0 to 70	LM431 ACM	Samples
LM431ACM3/NOPB	ACTIVE	SOT-23	DBZ	3	1000	Green (RoHS & no Sb/Br)	CU SN	Level-1-260C-UNLIM	0 to 70	N1F	Samples
LM431ACM3X	NRND	SOT-23	DBZ	3	3000	TBD	Call TI	Call TI	0 to 70	N1F	
LM431ACM3X/NOPB	ACTIVE	SOT-23	DBZ	3	3000	Green (RoHS & no Sb/Br)	CU SN	Level-1-260C-UNLIM	0 to 70	N1F	Samples
LM431ACMX/NOPB	ACTIVE	SOIC	D	8	2500	Green (RoHS & no Sb/Br)	CU SN	Level-1-260C-UNLIM	0 to 70	LM431 ACM	Samples
LM431ACZ/LFT3	ACTIVE	TO-92	LP	3	2000	Green (RoHS & no Sb/Br)	CU SN	N / A for Pkg Type		LM431 ACZ	Samples
LM431ACZ/LFT4	ACTIVE	TO-92	LP	3	2000	Green (RoHS & no Sb/Br)	CU SN	N / A for Pkg Type		LM431 ACZ	Samples
LM431ACZ/NOPB	ACTIVE	TO-92	LP	3	1800	Green (RoHS & no Sb/Br)	CU SN	N / A for Pkg Type	0 to 70	LM431 ACZ	Samples
LM431AIM	NRND	SOIC	D	8	95	TBD	Call TI	Call TI	-40 to 85	LM431 AIM	
LM431AIM/NOPB	ACTIVE	SOIC	D	8	95	Green (RoHS & no Sb/Br)	CU SN	Level-1-260C-UNLIM	-40 to 85	LM431 AIM	Samples
LM431AIM3	NRND	SOT-23	DBZ	3	1000	TBD	Call TI	Call TI	-40 to 85	N1E	
LM431AIM3/NOPB	ACTIVE	SOT-23	DBZ	3	1000	Green (RoHS & no Sb/Br)	CU SN	Level-1-260C-UNLIM	-40 to 85	N1E	Samples
LM431AIM3X/NOPB	ACTIVE	SOT-23	DBZ	3	3000	Green (RoHS & no Sb/Br)	CU SN	Level-1-260C-UNLIM	-40 to 85	N1E	Samples
LM431AIMX/NOPB	ACTIVE	SOIC	D	8	2500	Green (RoHS & no Sb/Br)	CU SN	Level-1-260C-UNLIM	-40 to 85	LM431 AIM	Samples
LM431AIZ/LFT1	ACTIVE	TO-92	LP	3	2000	Green (RoHS & no Sb/Br)	CU SN	N / A for Pkg Type		LM431 AIZ	Samples
LM431AIZ/NOPB	ACTIVE	TO-92	LP	3	1800	Green (RoHS & no Sb/Br)	CU SN	N / A for Pkg Type	-40 to 85	LM431 AIZ	Samples
LM431BCM/NOPB	ACTIVE	SOIC	D	8	95	Green (RoHS & no Sb/Br)	CU SN	Level-1-260C-UNLIM	0 to 70	431 BCM	Samples

Orderable Device	Status (1)	Package Type	Package Drawing	Pins	Package Qty	Eco Plan (2)	Lead/Ball Finish (6)	MSL Peak Temp (3)	Op Temp (°C)	Device Marking (4/5)	Samples
LM431BCM3	NRND	SOT-23	DBZ	3	1000	TBD	Call TI	Call TI	0 to 70	N1D	
LM431BCM3/NOPB	ACTIVE	SOT-23	DBZ	3	1000	Green (RoHS & no Sb/Br)	CU SN	Level-1-260C-UNLIM	0 to 70	N1D	Samples
LM431BCM3X/NOPB	ACTIVE	SOT-23	DBZ	3	3000	Green (RoHS & no Sb/Br)	CU SN	Level-1-260C-UNLIM	0 to 70	N1D	Samples
LM431BCMX/NOPB	ACTIVE	SOIC	D	8	2500	Green (RoHS & no Sb/Br)	CU SN	Level-1-260C-UNLIM	0 to 70	431 BCM	Samples
LM431BCZ/NOPB	ACTIVE	TO-92	LP	3	1800	Green (RoHS & no Sb/Br)	CU SN	N / A for Pkg Type	0 to 70	LM431 BCZ	Samples
LM431BIM	NRND	SOIC	D	8	95	TBD	Call TI	Call TI	-40 to 85	431 BIM	
LM431BIM/NOPB	ACTIVE	SOIC	D	8	95	Green (RoHS & no Sb/Br)	CU SN	Level-1-260C-UNLIM	-40 to 85	431 BIM	Samples
LM431BIM3	NRND	SOT-23	DBZ	3	1000	TBD	Call TI	Call TI	-40 to 85	N1C	
LM431BIM3/NOPB	ACTIVE	SOT-23	DBZ	3	1000	Green (RoHS & no Sb/Br)	CU SN	Level-1-260C-UNLIM	-40 to 85	N1C	Samples
LM431BIM3X	NRND	SOT-23	DBZ	3	3000	TBD	Call TI	Call TI	-40 to 85	N1C	
LM431BIM3X/NOPB	ACTIVE	SOT-23	DBZ	3	3000	Green (RoHS & no Sb/Br)	CU SN	Level-1-260C-UNLIM	-40 to 85	N1C	Samples
LM431BIMX/NOPB	ACTIVE	SOIC	D	8	2500	Green (RoHS & no Sb/Br)	CU SN	Level-1-260C-UNLIM	-40 to 85	431 BIM	Samples
LM431CCM/NOPB	ACTIVE	SOIC	D	8	95	Green (RoHS & no Sb/Br)	CU SN	Level-1-260C-UNLIM	0 to 70	431 CCM	Samples
LM431CCM3/NOPB	ACTIVE	SOT-23	DBZ	3	1000	Green (RoHS & no Sb/Br)	CU SN	Level-1-260C-UNLIM	0 to 70	N1B	Samples
LM431CCM3X	NRND	SOT-23	DBZ	3	3000	TBD	Call TI	Call TI	0 to 70	N1B	
LM431CCM3X/NOPB	ACTIVE	SOT-23	DBZ	3	3000	Green (RoHS & no Sb/Br)	CU SN	Level-1-260C-UNLIM	0 to 70	N1B	Samples
LM431CCZ/NOPB	ACTIVE	TO-92	LP	3	1800	Green (RoHS & no Sb/Br)	CU SN	N / A for Pkg Type	0 to 70	LM431 CCZ	Samples
LM431CIM	NRND	SOIC	D	8	95	TBD	Call TI	Call TI	-40 to 85	431 CIM	
LM431CIM/NOPB	ACTIVE	SOIC	D	8	95	Green (RoHS & no Sb/Br)	CU SN	Level-1-260C-UNLIM	-40 to 85	431 CIM	Samples
LM431CIM3	NRND	SOT-23	DBZ	3	1000	TBD	Call TI	Call TI	-40 to 85	N1A	

Orderable Device	Status (1)	Package Type	Package Drawing	Pins	Package Qty	Eco Plan (2)	Lead/Ball Finish (6)	MSL Peak Temp (3)	Op Temp (°C)	Device Marking (4/5)	Samples
LM431CIM3/NOPB	ACTIVE	SOT-23	DBZ	3	1000	Green (RoHS & no Sb/Br)	CU SN	Level-1-260C-UNLIM	-40 to 85	N1A	
LM431CIM3X	NRND	SOT-23	DBZ	3	3000	TBD	Call TI	Call TI	-40 to 85	N1A	
LM431CIM3X/NOPB	ACTIVE	SOT-23	DBZ	3	3000	Green (RoHS & no Sb/Br)	CU SN	Level-1-260C-UNLIM	-40 to 85	N1A	
LM431CIZ/NOPB	ACTIVE	TO-92	LP	3	1800	Green (RoHS & no Sb/Br)	CU SN	N / A for Pkg Type	-40 to 85	LM431 CIZ	

(1) The marketing status values are defined as follows:

ACTIVE: Product device recommended for new designs.

LIFEBUY: TI has announced that the device will be discontinued, and a lifetime-buy period is in effect.

NRND: Not recommended for new designs. Device is in production to support existing customers, but TI does not recommend using this part in a new design.

PREVIEW: Device has been announced but is not in production. Samples may or may not be available.

OBSELETE: TI has discontinued the production of the device.

(2) Eco Plan - The planned eco-friendly classification: Pb-Free (RoHS), Pb-Free (RoHS Exempt), or Green (RoHS & no Sb/Br) - please check <http://www.ti.com/productcontent> for the latest availability information and additional product content details.

TBD: The Pb-Free/Green conversion plan has not been defined.

Pb-Free (RoHS): TI's terms "Lead-Free" or "Pb-Free" mean semiconductor products that are compatible with the current RoHS requirements for all 6 substances, including the requirement that lead not exceed 0.1% by weight in homogeneous materials. Where designed to be soldered at high temperatures, TI Pb-Free products are suitable for use in specified lead-free processes.

Pb-Free (RoHS Exempt): This component has a RoHS exemption for either 1) lead-based flip-chip solder bumps used between the die and package, or 2) lead-based die adhesive used between the die and leadframe. The component is otherwise considered Pb-Free (RoHS compatible) as defined above.

Green (RoHS & no Sb/Br): TI defines "Green" to mean Pb-Free (RoHS compatible), and free of Bromine (Br) and Antimony (Sb) based flame retardants (Br or Sb do not exceed 0.1% by weight in homogeneous material)

(3) MSL, Peak Temp. - The Moisture Sensitivity Level rating according to the JEDEC industry standard classifications, and peak solder temperature.

(4) There may be additional marking, which relates to the logo, the lot trace code information, or the environmental category on the device.

(5) Multiple Device Markings will be inside parentheses. Only one Device Marking contained in parentheses and separated by a "-" will appear on a device. If a line is indented then it is a continuation of the previous line and the two combined represent the entire Device Marking for that device.

(6) Lead/Ball Finish - Orderable Devices may have multiple material finish options. Finish options are separated by a vertical ruled line. Lead/Ball Finish values may wrap to two lines if the finish value exceeds the maximum column width.

Important Information and Disclaimer: The information provided on this page represents TI's knowledge and belief as of the date that it is provided. TI bases its knowledge and belief on information provided by third parties, and makes no representation or warranty as to the accuracy of such information. Efforts are underway to better integrate information from third parties. TI has taken and

continues to take reasonable steps to provide representative and accurate information but may not have conducted destructive testing or chemical analysis on incoming materials and chemicals. TI and TI suppliers consider certain information to be proprietary, and thus CAS numbers and other limited information may not be available for release.

In no event shall TI's liability arising out of such information exceed the total purchase price of the TI part(s) at issue in this document sold by TI to Customer on an annual basis.

TAPE AND REEL INFORMATION



QUADRANT ASSIGNMENTS FOR PIN 1 ORIENTATION IN TAPE



*All dimensions are nominal

Device	Package Type	Package Drawing	Pins	SPQ	Reel Diameter (mm)	Reel Width W1 (mm)	A0 (mm)	B0 (mm)	K0 (mm)	P1 (mm)	W (mm)	Pin1 Quadrant
LM431ACM3/NOPB	SOT-23	DBZ	3	1000	178.0	8.4	3.3	2.9	1.22	4.0	8.0	Q3
LM431ACM3X	SOT-23	DBZ	3	3000	178.0	8.4	3.3	2.9	1.22	4.0	8.0	Q3
LM431ACM3X/NOPB	SOT-23	DBZ	3	3000	178.0	8.4	3.3	2.9	1.22	4.0	8.0	Q3
LM431ACMX/NOPB	SOIC	D	8	2500	330.0	12.4	6.5	5.4	2.0	8.0	12.0	Q1
LM431AIM3	SOT-23	DBZ	3	1000	178.0	8.4	3.3	2.9	1.22	4.0	8.0	Q3
LM431AIM3/NOPB	SOT-23	DBZ	3	1000	178.0	8.4	3.3	2.9	1.22	4.0	8.0	Q3
LM431AIM3X/NOPB	SOT-23	DBZ	3	3000	178.0	8.4	3.3	2.9	1.22	4.0	8.0	Q3
LM431AIMX/NOPB	SOIC	D	8	2500	330.0	12.4	6.5	5.4	2.0	8.0	12.0	Q1
LM431BCM3	SOT-23	DBZ	3	1000	178.0	8.4	3.3	2.9	1.22	4.0	8.0	Q3
LM431BCM3/NOPB	SOT-23	DBZ	3	1000	178.0	8.4	3.3	2.9	1.22	4.0	8.0	Q3
LM431BCM3X/NOPB	SOT-23	DBZ	3	3000	178.0	8.4	3.3	2.9	1.22	4.0	8.0	Q3
LM431BCMX/NOPB	SOIC	D	8	2500	330.0	12.4	6.5	5.4	2.0	8.0	12.0	Q1
LM431BIM3	SOT-23	DBZ	3	1000	178.0	8.4	3.3	2.9	1.22	4.0	8.0	Q3
LM431BIM3/NOPB	SOT-23	DBZ	3	1000	178.0	8.4	3.3	2.9	1.22	4.0	8.0	Q3
LM431BIM3X	SOT-23	DBZ	3	3000	178.0	8.4	3.3	2.9	1.22	4.0	8.0	Q3
LM431BIM3X/NOPB	SOT-23	DBZ	3	3000	178.0	8.4	3.3	2.9	1.22	4.0	8.0	Q3
LM431BIMX/NOPB	SOIC	D	8	2500	330.0	12.4	6.5	5.4	2.0	8.0	12.0	Q1
LM431CCM3/NOPB	SOT-23	DBZ	3	1000	178.0	8.4	3.3	2.9	1.22	4.0	8.0	Q3

Device	Package Type	Package Drawing	Pins	SPQ	Reel Diameter (mm)	Reel Width W1 (mm)	A0 (mm)	B0 (mm)	K0 (mm)	P1 (mm)	W (mm)	Pin1 Quadrant
LM431CCM3X	SOT-23	DBZ	3	3000	178.0	8.4	3.3	2.9	1.22	4.0	8.0	Q3
LM431CCM3X/NOPB	SOT-23	DBZ	3	3000	178.0	8.4	3.3	2.9	1.22	4.0	8.0	Q3
LM431CIM3	SOT-23	DBZ	3	1000	178.0	8.4	3.3	2.9	1.22	4.0	8.0	Q3
LM431CIM3/NOPB	SOT-23	DBZ	3	1000	178.0	8.4	3.3	2.9	1.22	4.0	8.0	Q3
LM431CIM3X	SOT-23	DBZ	3	3000	178.0	8.4	3.3	2.9	1.22	4.0	8.0	Q3
LM431CIM3X/NOPB	SOT-23	DBZ	3	3000	178.0	8.4	3.3	2.9	1.22	4.0	8.0	Q3

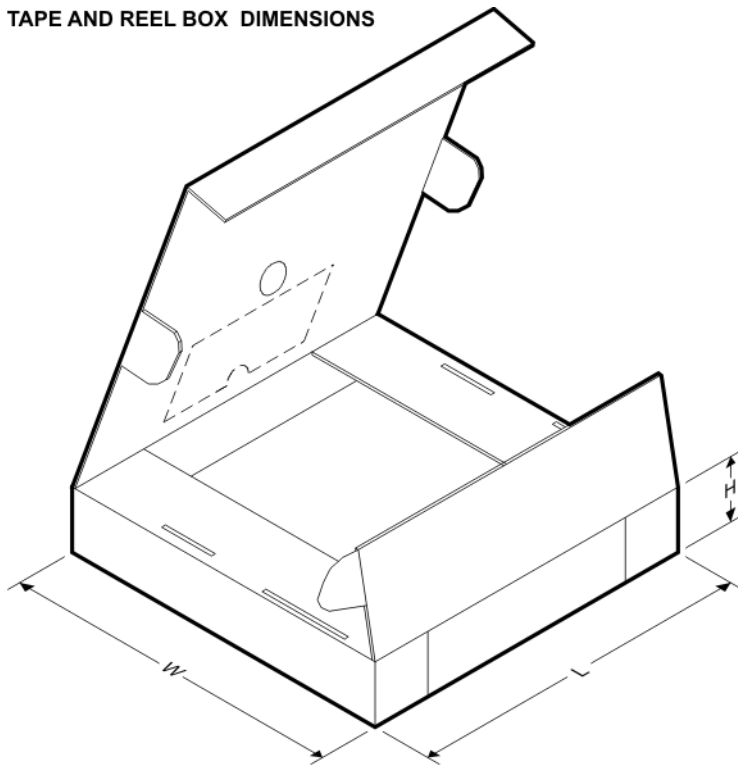
TAPE AND REEL BOX DIMENSIONS

*All dimensions are nominal

Device	Package Type	Package Drawing	Pins	SPQ	Length (mm)	Width (mm)	Height (mm)
LM431ACM3/NOPB	SOT-23	DBZ	3	1000	210.0	185.0	35.0
LM431ACM3X	SOT-23	DBZ	3	3000	210.0	185.0	35.0
LM431ACM3X/NOPB	SOT-23	DBZ	3	3000	210.0	185.0	35.0
LM431ACMX/NOPB	SOIC	D	8	2500	367.0	367.0	35.0
LM431AIM3	SOT-23	DBZ	3	1000	210.0	185.0	35.0
LM431AIM3/NOPB	SOT-23	DBZ	3	1000	210.0	185.0	35.0
LM431AIM3X/NOPB	SOT-23	DBZ	3	3000	210.0	185.0	35.0
LM431AIMX/NOPB	SOIC	D	8	2500	367.0	367.0	35.0
LM431BCM3	SOT-23	DBZ	3	1000	210.0	185.0	35.0
LM431BCM3/NOPB	SOT-23	DBZ	3	1000	210.0	185.0	35.0
LM431BCM3X/NOPB	SOT-23	DBZ	3	3000	210.0	185.0	35.0

Device	Package Type	Package Drawing	Pins	SPQ	Length (mm)	Width (mm)	Height (mm)
LM431BCM3/NOPB	SOIC	D	8	2500	367.0	367.0	35.0
LM431BIM3	SOT-23	DBZ	3	1000	210.0	185.0	35.0
LM431BIM3/NOPB	SOT-23	DBZ	3	1000	210.0	185.0	35.0
LM431BIM3X	SOT-23	DBZ	3	3000	210.0	185.0	35.0
LM431BIM3X/NOPB	SOT-23	DBZ	3	3000	210.0	185.0	35.0
LM431BIMX/NOPB	SOIC	D	8	2500	367.0	367.0	35.0
LM431CCM3/NOPB	SOT-23	DBZ	3	1000	210.0	185.0	35.0
LM431CCM3X	SOT-23	DBZ	3	3000	210.0	185.0	35.0
LM431CCM3X/NOPB	SOT-23	DBZ	3	3000	210.0	185.0	35.0
LM431CIM3	SOT-23	DBZ	3	1000	210.0	185.0	35.0
LM431CIM3/NOPB	SOT-23	DBZ	3	1000	210.0	185.0	35.0
LM431CIM3X	SOT-23	DBZ	3	3000	210.0	185.0	35.0
LM431CIM3X/NOPB	SOT-23	DBZ	3	3000	210.0	185.0	35.0

GENERIC PACKAGE VIEW

DBZ 3

SOT-23 - 1.12 mm max height

SMALL OUTLINE TRANSISTOR

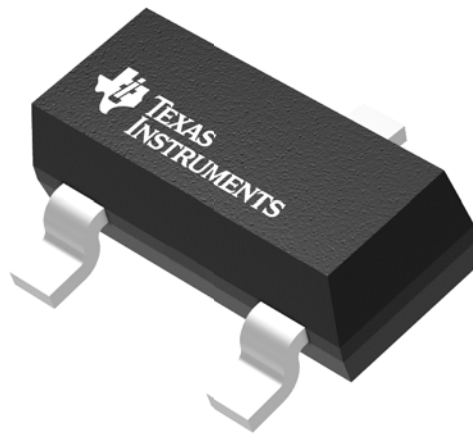

Images above are just a representation of the package family, actual package may vary.
Refer to the product data sheet for package details.

4203227/C

DBZ0003A

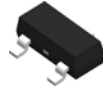

PACKAGE OUTLINE

SOT-23 - 1.12 mm max height

SMALL OUTLINE TRANSISTOR

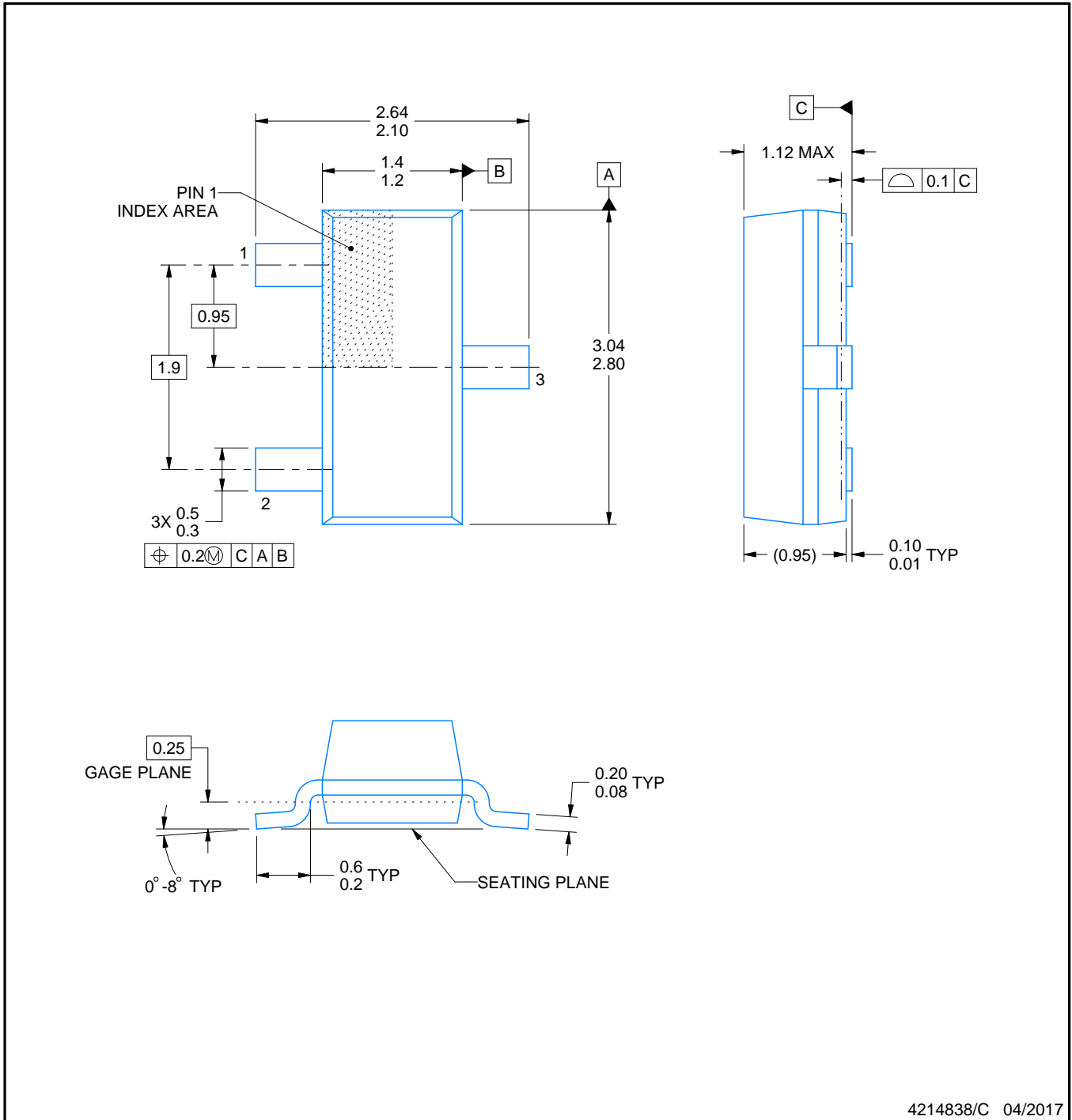

4214838/C 04/2017

NOTES:

1. All linear dimensions are in millimeters. Any dimensions in parenthesis are for reference only. Dimensioning and tolerancing per ASME Y14.5M.
2. This drawing is subject to change without notice.
3. Reference JEDEC registration TO-236, except minimum foot length.

EXAMPLE BOARD LAYOUT

DBZ0003A

SOT-23 - 1.12 mm max height

SMALL OUTLINE TRANSISTOR

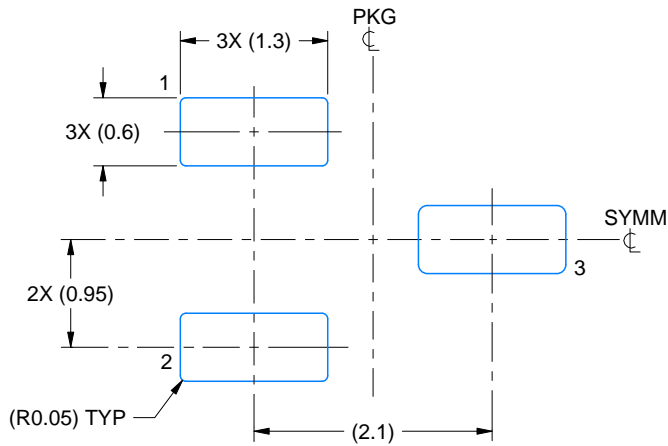

LAND PATTERN EXAMPLE
SCALE:15X

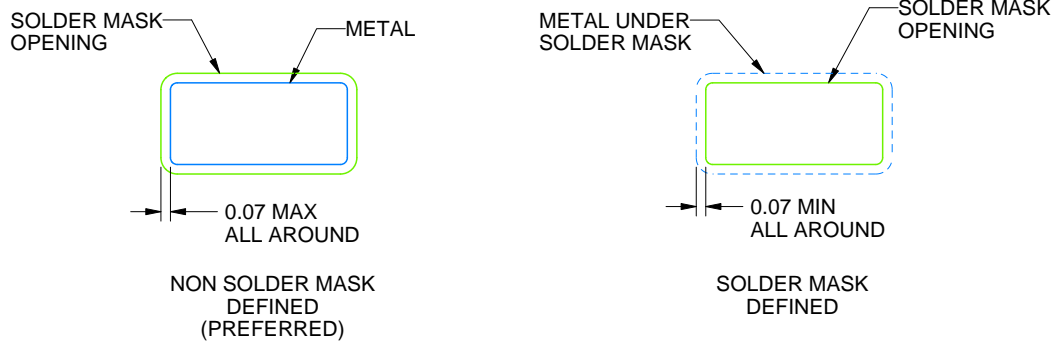

SOLDER MASK DETAILS

4214838/C 04/2017

NOTES: (continued)

4. Publication IPC-7351 may have alternate designs.
5. Solder mask tolerances between and around signal pads can vary based on board fabrication site.

EXAMPLE STENCIL DESIGN

DBZ0003A

SOT-23 - 1.12 mm max height

SMALL OUTLINE TRANSISTOR

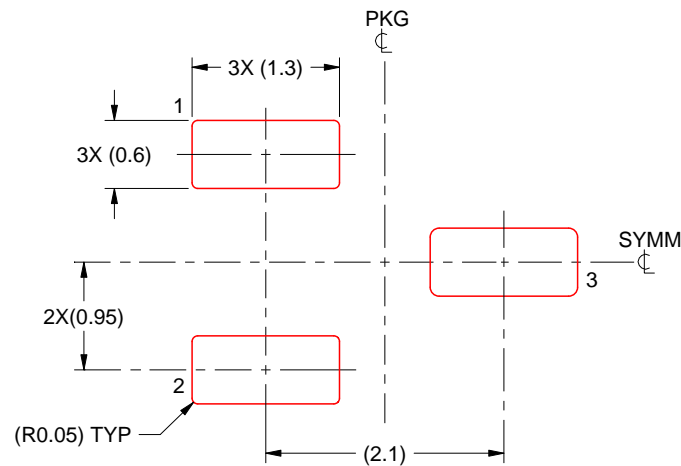

SOLDER PASTE EXAMPLE
BASED ON 0.125 THICK STENCIL
SCALE:15X

4214838/C 04/2017

NOTES: (continued)

6. Laser cutting apertures with trapezoidal walls and rounded corners may offer better paste release. IPC-7525 may have alternate design recommendations.
7. Board assembly site may have different recommendations for stencil design.

D (R-PDSO-G8)

PLASTIC SMALL OUTLINE

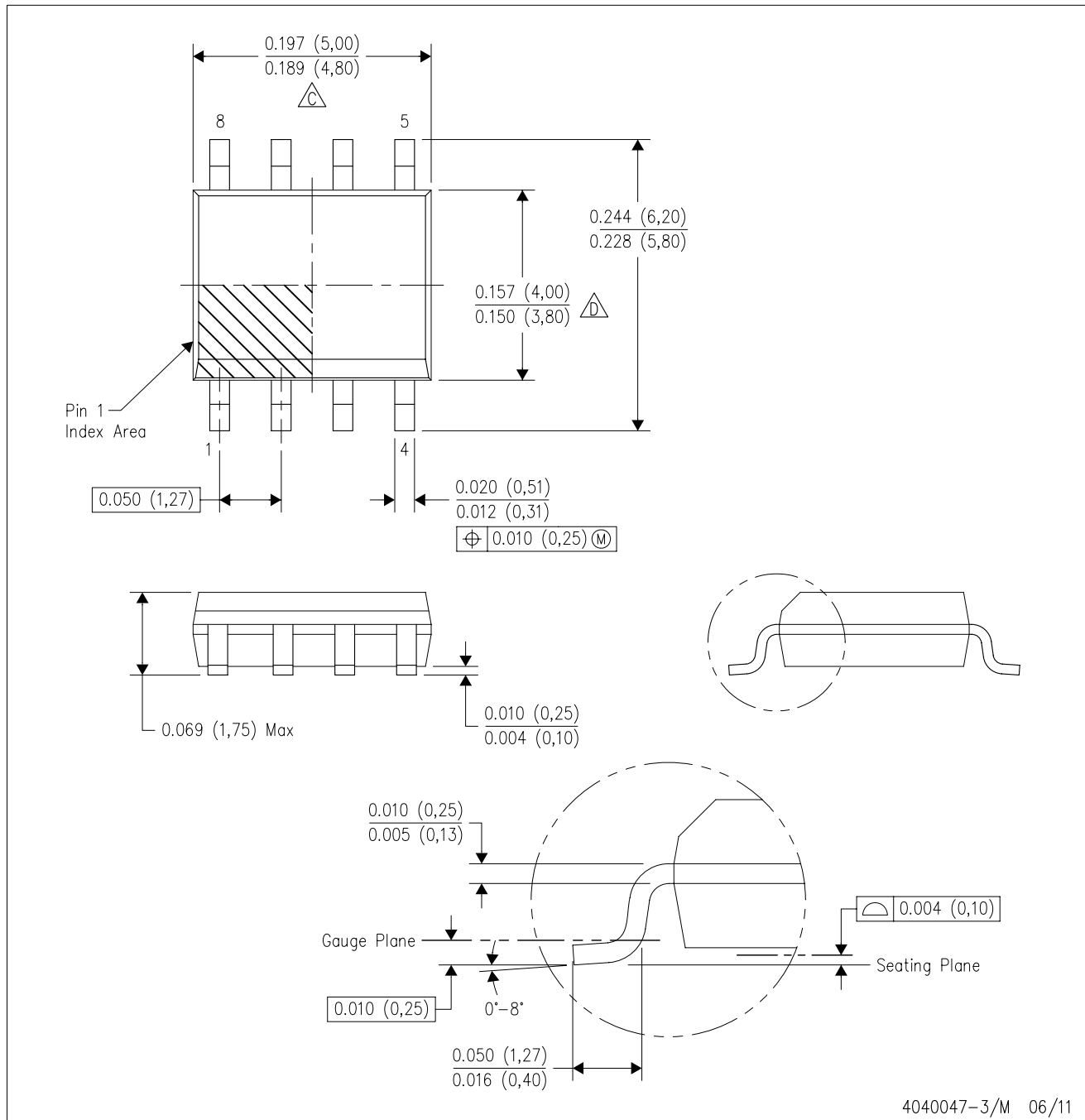

4040047-3/M 06/11

GENERIC PACKAGE VIEW

LP 3

TO-92 - 5.34 mm max height

TRANSISTOR OUTLINE



Images above are just a representation of the package family, actual package may vary.
Refer to the product data sheet for package details.

4040001-2/F

LP0003A



PACKAGE OUTLINE

TO-92 - 5.34 mm max height

TO-92



4215214/B 04/2017

NOTES:

1. All linear dimensions are in millimeters. Any dimensions in parenthesis are for reference only. Dimensioning and tolerancing per ASME Y14.5M.
2. This drawing is subject to change without notice.
3. Lead dimensions are not controlled within this area.
4. Reference JEDEC TO-226, variation AA.
5. Shipping method:
 - a. Straight lead option available in bulk pack only.
 - b. Formed lead option available in tape and reel or ammo pack.
 - c. Specific products can be offered in limited combinations of shipping medium and lead options.
 - d. Consult product folder for more information on available options.

EXAMPLE BOARD LAYOUT

LP0003A

TO-92 - 5.34 mm max height

TO-92

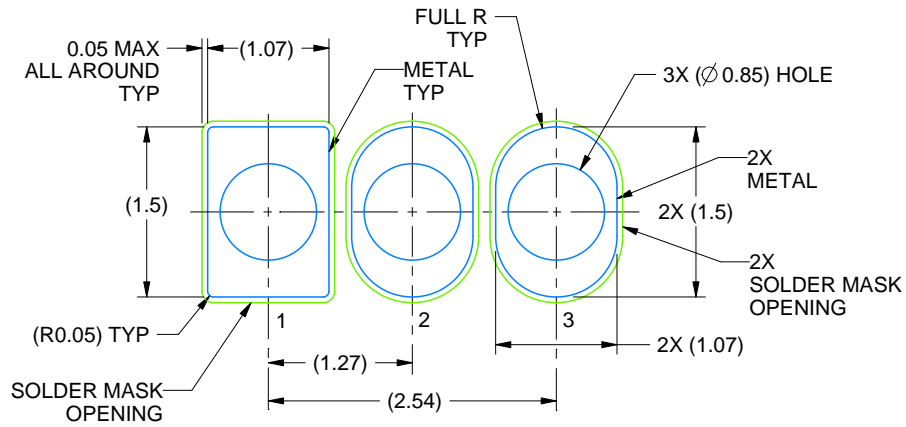

LAND PATTERN EXAMPLE
STRAIGHT LEAD OPTION
NON-SOLDER MASK DEFINED
SCALE:15X



LAND PATTERN EXAMPLE
FORMED LEAD OPTION
NON-SOLDER MASK DEFINED
SCALE:15X

4215214/B 04/2017

TAPE SPECIFICATIONS

LP0003A

TO-92 - 5.34 mm max height

TO-92

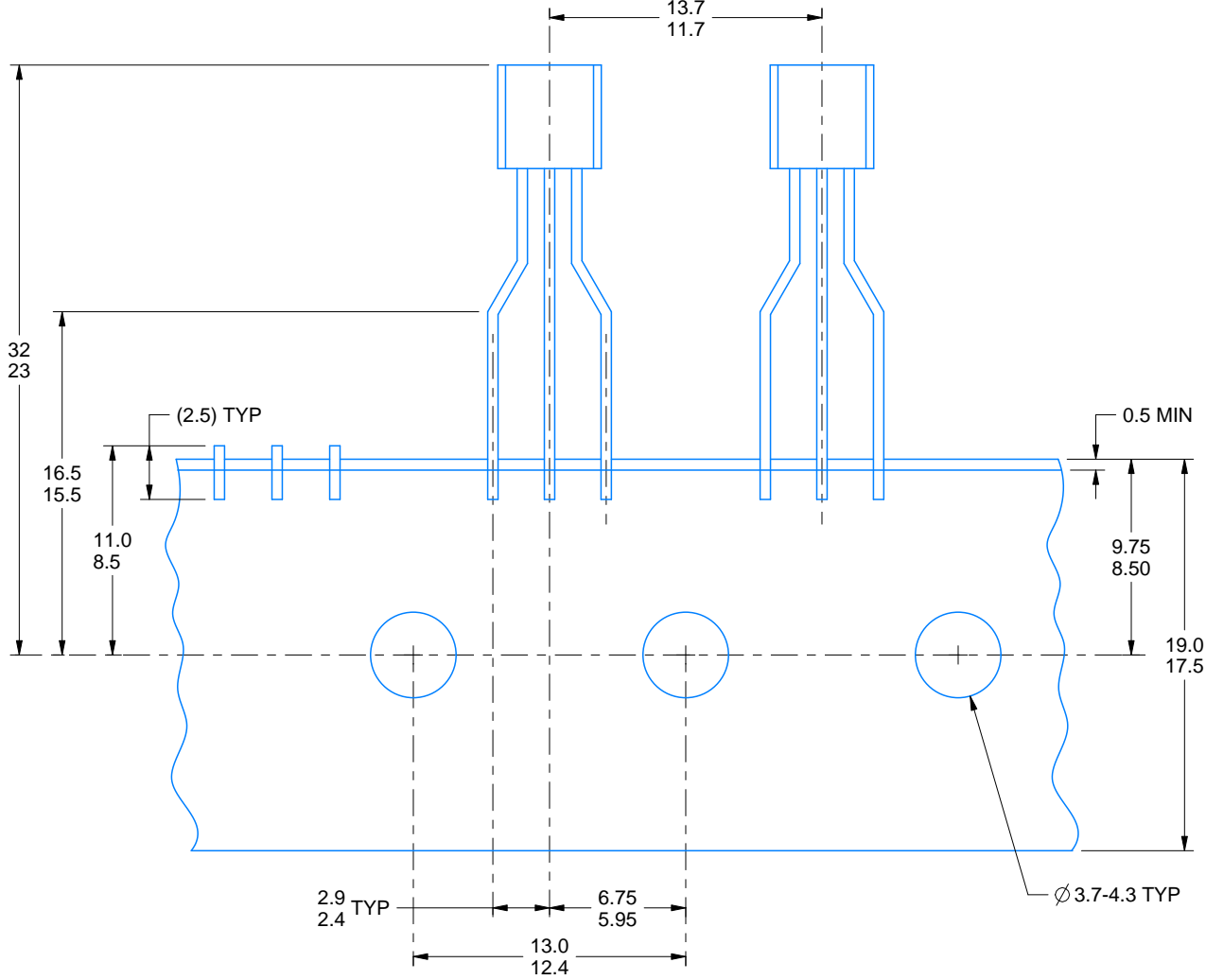

FOR FORMED LEAD OPTION PACKAGE

4215214/B 04/2017

IMPORTANT NOTICE

Texas Instruments Incorporated (TI) reserves the right to make corrections, enhancements, improvements and other changes to its semiconductor products and services per JESD46, latest issue, and to discontinue any product or service per JESD48, latest issue. Buyers should obtain the latest relevant information before placing orders and should verify that such information is current and complete.

TI's published terms of sale for semiconductor products (<http://www.ti.com/sc/docs/stdterms.htm>) apply to the sale of packaged integrated circuit products that TI has qualified and released to market. Additional terms may apply to the use or sale of other types of TI products and services.

Reproduction of significant portions of TI information in TI data sheets is permissible only if reproduction is without alteration and is accompanied by all associated warranties, conditions, limitations, and notices. TI is not responsible or liable for such reproduced documentation. Information of third parties may be subject to additional restrictions. Resale of TI products or services with statements different from or beyond the parameters stated by TI for that product or service voids all express and any implied warranties for the associated TI product or service and is an unfair and deceptive business practice. TI is not responsible or liable for any such statements.

Buyers and others who are developing systems that incorporate TI products (collectively, "Designers") understand and agree that Designers remain responsible for using their independent analysis, evaluation and judgment in designing their applications and that Designers have full and exclusive responsibility to assure the safety of Designers' applications and compliance of their applications (and of all TI products used in or for Designers' applications) with all applicable regulations, laws and other applicable requirements. Designer represents that, with respect to their applications, Designer has all the necessary expertise to create and implement safeguards that (1) anticipate dangerous consequences of failures, (2) monitor failures and their consequences, and (3) lessen the likelihood of failures that might cause harm and take appropriate actions. Designer agrees that prior to using or distributing any applications that include TI products, Designer will thoroughly test such applications and the functionality of such TI products as used in such applications.

TI's provision of technical, application or other design advice, quality characterization, reliability data or other services or information, including, but not limited to, reference designs and materials relating to evaluation modules, (collectively, "TI Resources") are intended to assist designers who are developing applications that incorporate TI products; by downloading, accessing or using TI Resources in any way, Designer (individually or, if Designer is acting on behalf of a company, Designer's company) agrees to use any particular TI Resource solely for this purpose and subject to the terms of this Notice.

TI's provision of TI Resources does not expand or otherwise alter TI's applicable published warranties or warranty disclaimers for TI products, and no additional obligations or liabilities arise from TI providing such TI Resources. TI reserves the right to make corrections, enhancements, improvements and other changes to its TI Resources. TI has not conducted any testing other than that specifically described in the published documentation for a particular TI Resource.

Designer is authorized to use, copy and modify any individual TI Resource only in connection with the development of applications that include the TI product(s) identified in such TI Resource. NO OTHER LICENSE, EXPRESS OR IMPLIED, BY ESTOPPEL OR OTHERWISE TO ANY OTHER TI INTELLECTUAL PROPERTY RIGHT, AND NO LICENSE TO ANY TECHNOLOGY OR INTELLECTUAL PROPERTY RIGHT OF TI OR ANY THIRD PARTY IS GRANTED HEREIN, including but not limited to any patent right, copyright, mask work right, or other intellectual property right relating to any combination, machine, or process in which TI products or services are used. Information regarding or referencing third-party products or services does not constitute a license to use such products or services, or a warranty or endorsement thereof. Use of TI Resources may require a license from a third party under the patents or other intellectual property of the third party, or a license from TI under the patents or other intellectual property of TI.

TI RESOURCES ARE PROVIDED "AS IS" AND WITH ALL FAULTS. TI DISCLAIMS ALL OTHER WARRANTIES OR REPRESENTATIONS, EXPRESS OR IMPLIED, REGARDING RESOURCES OR USE THEREOF, INCLUDING BUT NOT LIMITED TO ACCURACY OR COMPLETENESS, TITLE, ANY EPIDEMIC FAILURE WARRANTY AND ANY IMPLIED WARRANTIES OF MERCHANTABILITY, FITNESS FOR A PARTICULAR PURPOSE, AND NON-INFRINGEMENT OF ANY THIRD PARTY INTELLECTUAL PROPERTY RIGHTS. TI SHALL NOT BE LIABLE FOR AND SHALL NOT DEFEND OR INDEMNIFY DESIGNER AGAINST ANY CLAIM, INCLUDING BUT NOT LIMITED TO ANY INFRINGEMENT CLAIM THAT RELATES TO OR IS BASED ON ANY COMBINATION OF PRODUCTS EVEN IF DESCRIBED IN TI RESOURCES OR OTHERWISE. IN NO EVENT SHALL TI BE LIABLE FOR ANY ACTUAL, DIRECT, SPECIAL, COLLATERAL, INDIRECT, PUNITIVE, INCIDENTAL, CONSEQUENTIAL OR EXEMPLARY DAMAGES IN CONNECTION WITH OR ARISING OUT OF TI RESOURCES OR USE THEREOF, AND REGARDLESS OF WHETHER TI HAS BEEN ADVISED OF THE POSSIBILITY OF SUCH DAMAGES.

Unless TI has explicitly designated an individual product as meeting the requirements of a particular industry standard (e.g., ISO/TS 16949 and ISO 26262), TI is not responsible for any failure to meet such industry standard requirements.



Where TI specifically promotes products as facilitating functional safety or as compliant with industry functional safety standards, such products are intended to help enable customers to design and create their own applications that meet applicable functional safety standards and requirements. Using products in an application does not by itself establish any safety features in the application. Designers must ensure compliance with safety-related requirements and standards applicable to their applications. Designer may not use any TI products in life-critical medical equipment unless authorized officers of the parties have executed a special contract specifically governing such use. Life-critical medical equipment is medical equipment where failure of such equipment would cause serious bodily injury or death (e.g., life support, pacemakers, defibrillators, heart pumps, neurostimulators, and implantables). Such equipment includes, without limitation, all medical devices identified by the U.S. Food and Drug Administration as Class III devices and equivalent classifications outside the U.S.

TI may expressly designate certain products as completing a particular qualification (e.g., Q100, Military Grade, or Enhanced Product). Designers agree that it has the necessary expertise to select the product with the appropriate qualification designation for their applications and that proper product selection is at Designers' own risk. Designers are solely responsible for compliance with all legal and regulatory requirements in connection with such selection.

Designer will fully indemnify TI and its representatives against any damages, costs, losses, and/or liabilities arising out of Designer's non-compliance with the terms and provisions of this Notice.

Looking for pricing, stock, or lifecycle information?

Click below to explore more details on WIN SOURCE:

-  [View LM431BCM/NOPB on WIN SOURCE](#)
-  [Texas Instruments](#) Information

Optimize Your Supply Chain with WIN SOURCE Solutions

-  Global Sourcing Solution
-  Obsolete Management
-  Cost Control Management
-  Shortage Management
-  Alternative Solution
-  Excess Inventory Management