



THE DATASHEET OF
3709





Adafruit SGP30 TVOC/eCO2 Gas Sensor

Created by lady ada

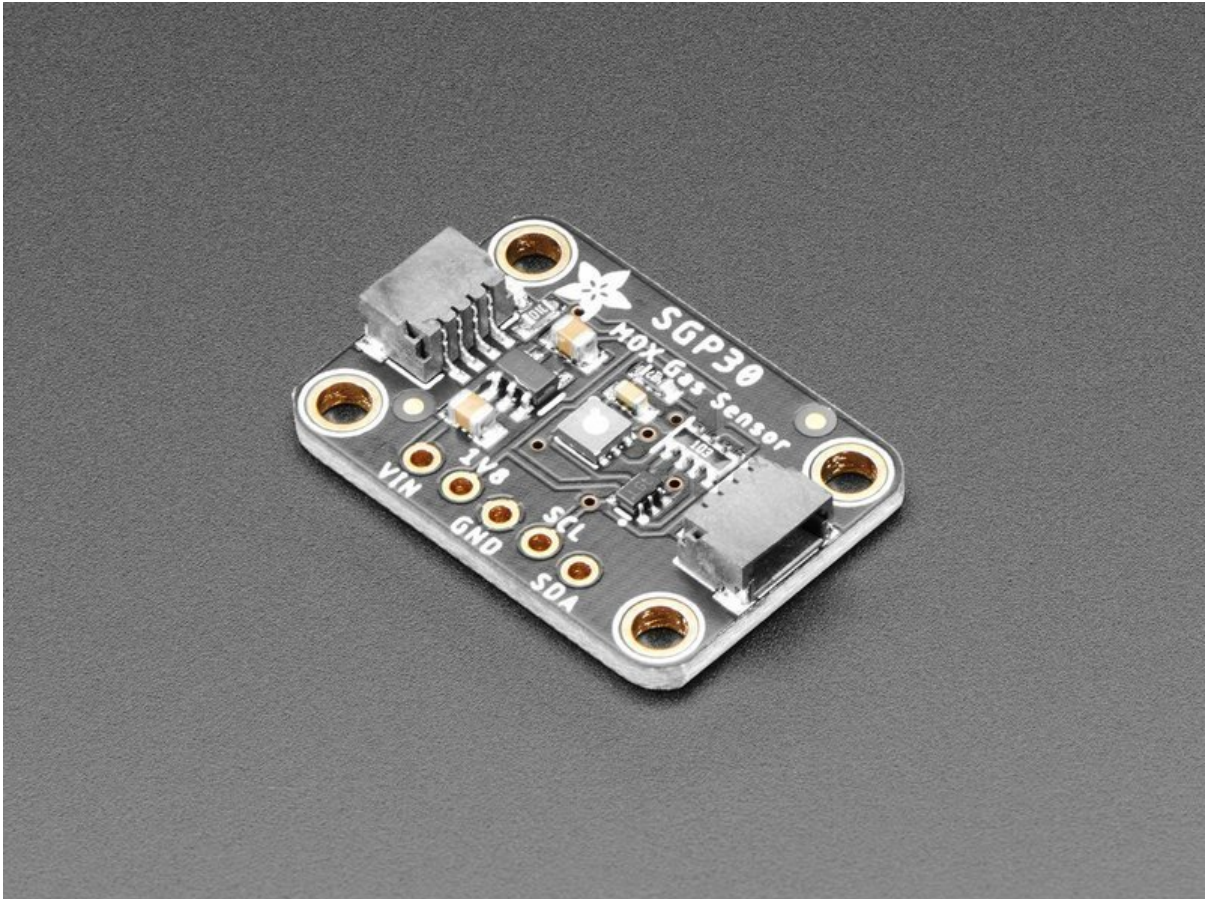

<https://learn.adafruit.com/adafruit-sgp30-gas-tvoc-eco2-mox-sensor>

Last updated on 2024-06-03 02:16:53 PM EDT

Table of Contents

Overview	3
Pinouts	6
<ul style="list-style-type: none">• Data Pins• Power Pins:	
Arduino Test	7
<ul style="list-style-type: none">• Wiring• Install Adafruit_SGP30 library• Load Demo• Baseline Set & Get	
Arduino Library Docs	13
Python & CircuitPython Test	13
<ul style="list-style-type: none">• CircuitPython MicroController Wiring• Python Computer Wiring• CircuitPython Installation of SGP30 Library• Python Installation of SGP30 Library• CircuitPython & Python Usage• Baseline Set & Get	
Python Library Docs	20
WipperSnapper	20
<ul style="list-style-type: none">• What is WipperSnapper• Wiring• Usage	
Download	27
<ul style="list-style-type: none">• Files:• Schematic STEMMA QT Version• Fabrication Print STEMMA QT Version• Schematic & Fabrication Print Original Version	

Overview

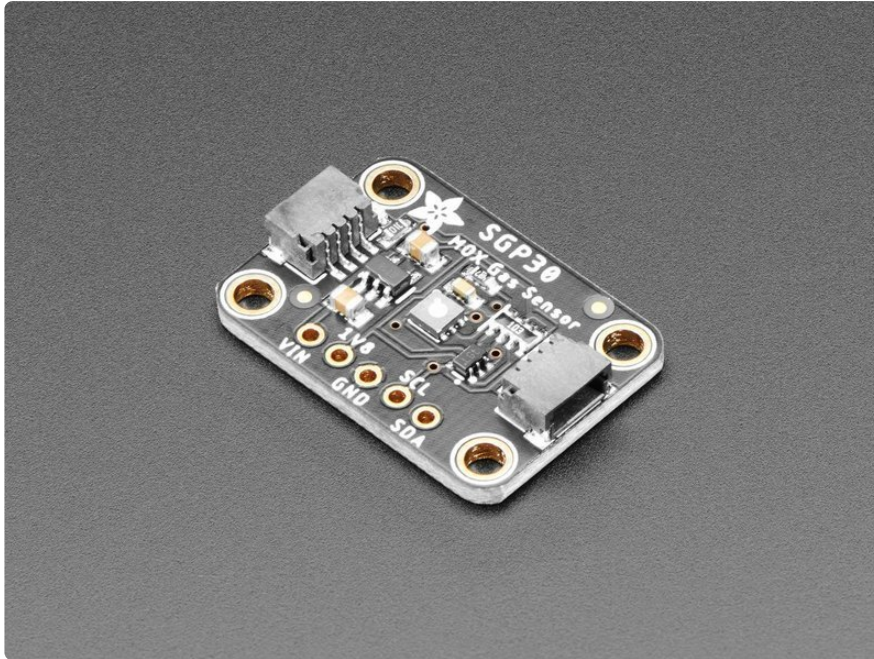

Breathe easy with the SGP30 Multi-Pixel Gas Sensor, a fully integrated MOX gas sensor. This is a very fine air quality sensor from the sensor experts at Sensirion, with I2C interfacing and fully calibrated output signals with a typical accuracy of 15% within measured values. The SGP combines multiple metal-oxide sensing elements on one chip to provide more detailed air quality signals.

This is a gas sensor that can detect a wide range of Volatile Organic Compounds (VOCs) and H₂ and is intended for indoor air quality monitoring. When connected to your microcontroller (running our library code) it will return a Total Volatile Organic Compound (TVOC) reading and an equivalent carbon dioxide reading (eCO₂) over I2C.

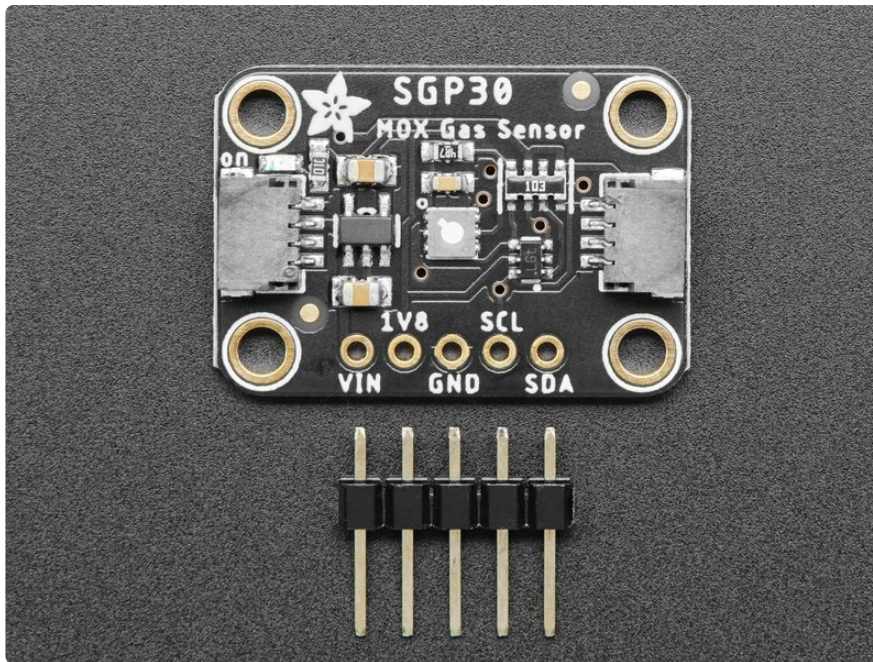

The SGP30 has a 'standard' hot-plate MOX sensor, as well as a small microcontroller that controls power to the plate, reads the analog voltage, tracks the baseline calibration, calculates TVOC and eCO₂ values, and provides an I²C interface to read from. Unlike the CCS811, this sensor does not require I²C clock stretching.

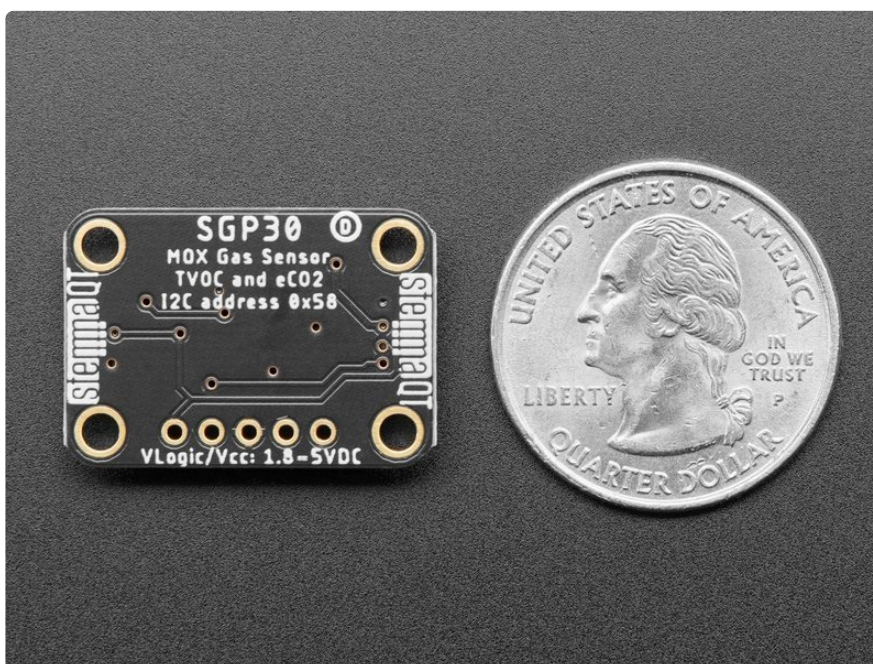

This part will measure **eCO₂** (equivalent calculated carbon-dioxide) concentration within a range of 400 to 60,000 parts per million (ppm), and **TVOC** (Total Volatile Organic Compound) concentration within a range of 0 to 60,000 parts per billion (ppb).

Please note, this sensor, like all VOC/gas sensors, has variability and to get precise measurements you will want to calibrate it against known sources! That said, for

general environmental sensors, it will give you a good idea of trends and comparison. The SGP30 does have built in calibration capabilities, note that eCO2 is calculated based on H2 concentration, it is not a 'true' CO2 sensor for laboratory use.

Another nice element to this sensor is the ability to set humidity compensation for better accuracy. An external humidity sensor is required and then the RH% is written over I2C to the sensor, so it can better calculate the TVOC/eCO2 values.

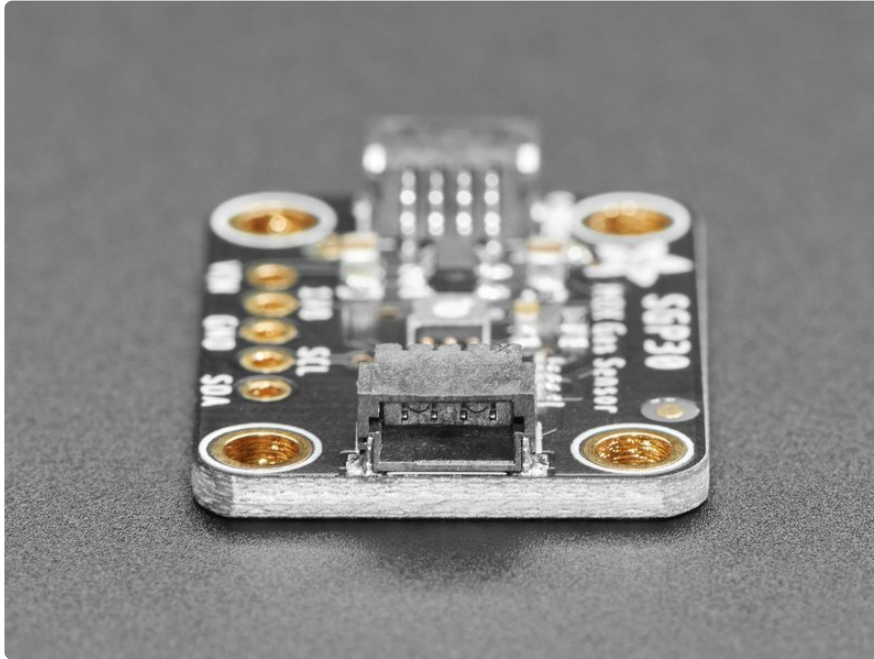

Nice sensor right? So we made it easy for you to get right into your next project. The surface-mount sensor is soldered onto a custom made PCB in the [STEMMA QT form factor \(https://adafru.it/LBQ\)](https://adafru.it/LBQ), making them easy to interface with. The [STEMMA QT connectors \(https://adafru.it/JqB\)](https://adafru.it/JqB) on either side are compatible with the [SparkFun Qwiic \(https://adafru.it/Fpw\)](https://adafru.it/Fpw) I2C connectors. This allows you to make solderless connections between your development board and the SGP30 or to chain it with a wide range of other sensors and accessories using a [compatible cable \(https://adafru.it/JnB\)](https://adafru.it/JnB).

We've of course broken out all the pins to standard headers and added a 1.8V voltage regulator and level shifting so allow you to use it with either 3.3V or 5V systems such as the Raspberry Pi, or Metro M4 or Arduino Uno.

There are two versions of this board - the STEMMA QT version shown above, and the original header-only version shown below. Code works the same on both!

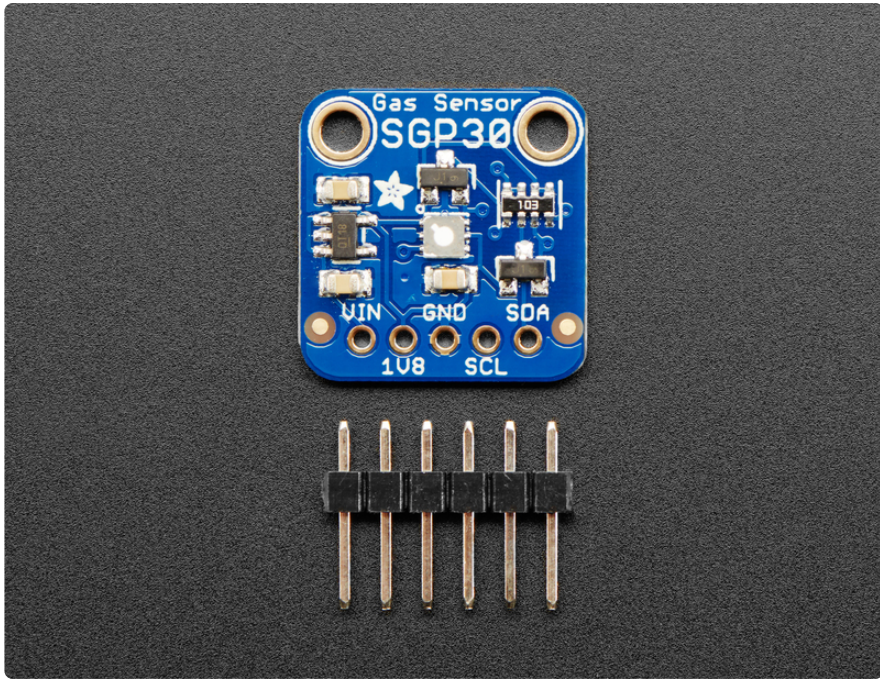

Pinouts

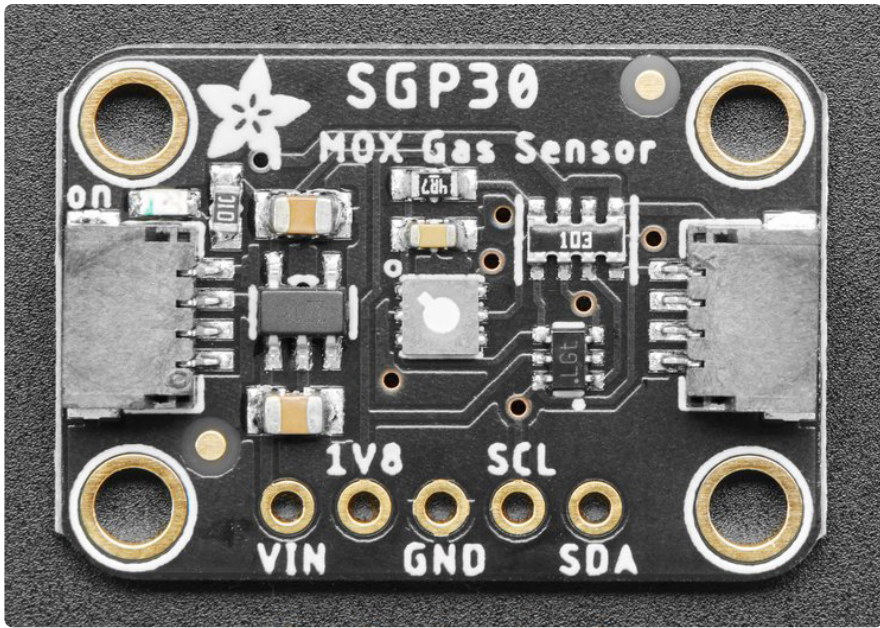

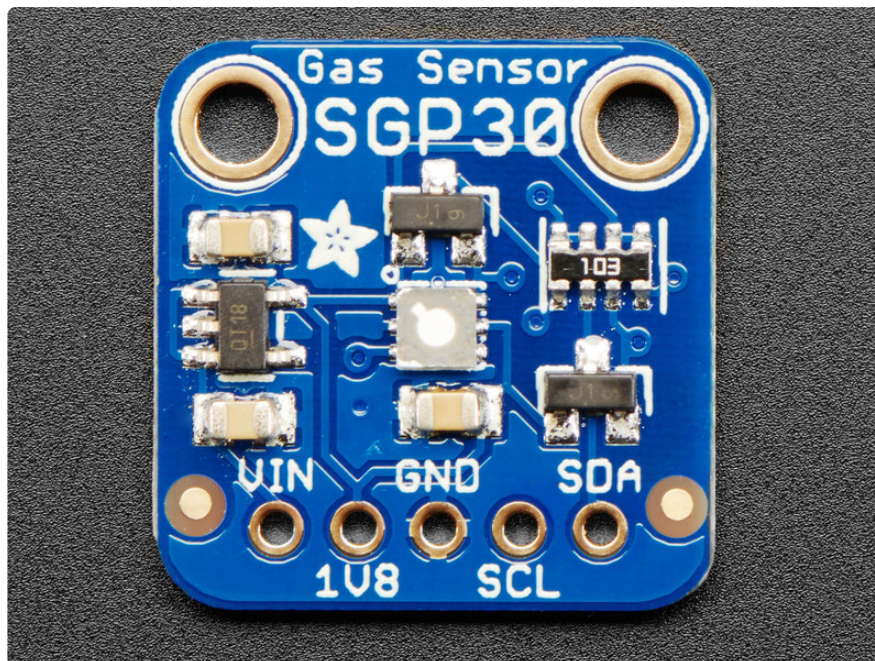

Power Pins:

- **Vin** - this is the power pin. Since the sensor chip uses 3 VDC for logic, we have included a voltage regulator on board that will take 3-5VDC and safely convert it down. To power the board, give it the same power as the logic level of your microcontroller - e.g. for a 5V micro like Arduino, use 5V
- **1V8** - this is the 1.8V output from the voltage regulator, you can grab up to 50mA from this if you like
- **GND** - common ground for power and logic

Data Pins

- **SCL** - I2C clock pin, connect to your microcontrollers I2C clock line. Can use 3V or 5V logic, and has a 10K pullup to **Vin**
- **SDA** - I2C data pin, connect to your microcontrollers I2C data line. Can use 3V or 5V logic, and has a 10K pullup to **Vin**
- **STEMMA QT** (<https://adafru.it/Ft4>) - These connectors allow you to connect to dev boards with **STEMMA QT** connectors or to other things with [various associated accessories](https://adafru.it/Ft6) (<https://adafru.it/Ft6>)

Arduino Test

You can easily wire this breakout to any microcontroller; we'll be using an Arduino.

Start by soldering the headers to the SGP30 breakout board. Check out the [Adafruit guide to excellent soldering \(https://adafru.it/dxy\)](https://adafru.it/dxy) if you're new to soldering. Then continue on below to learn how to wire it to a Metro.

The sensor uses I2C address 0x58 and cannot be changed.

Wiring

Connect the SGP30 breakout to your board using an I2C connection. Here's an example with an Arduino-compatible Metro:

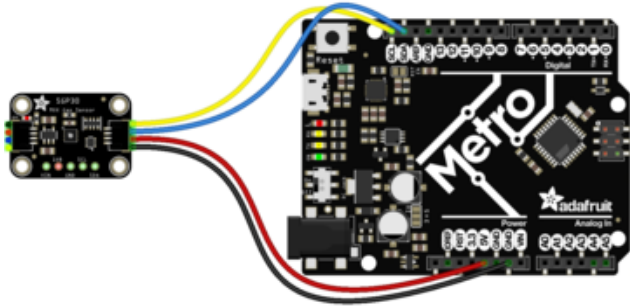

fritzing

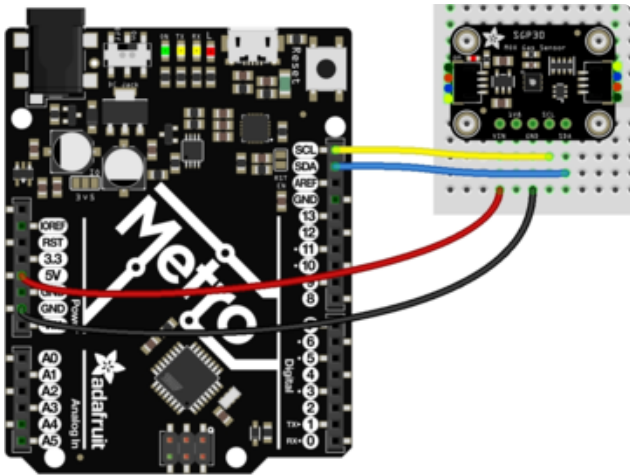

Board 5V to Sensor Vin (red wire on STEMMA QT version). (Metro is a 5V logic chip)

Board ground / GND to sensor ground / GND (black wire on STEMMA QT version). Board SCL to sensor SCL (yellow wire on STEMMA QT version).

Board SDA to sensor SDA (blue wire on STEMMA QT version).

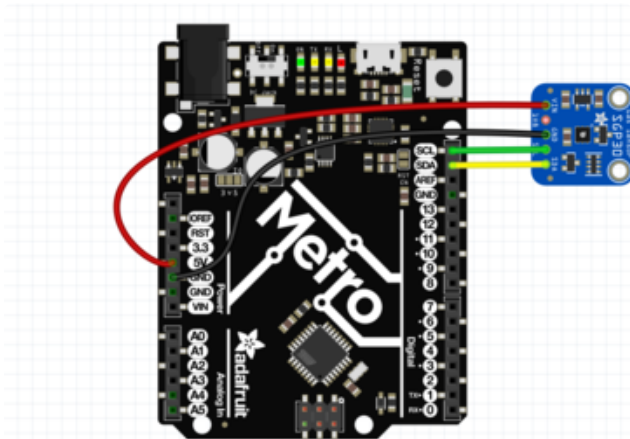

ing

Metro Original Fritzing File

<https://adafru.it/At6>

Install Adafruit_SGP30 library

To begin reading sensor data, you will need to [install the Adafruit_SGP30 library \(code on our github repository\)](https://adafru.it/BnZ) (<https://adafru.it/BnZ>). It is available from the Arduino library manager so we recommend using that.

From the IDE open up the library manager...

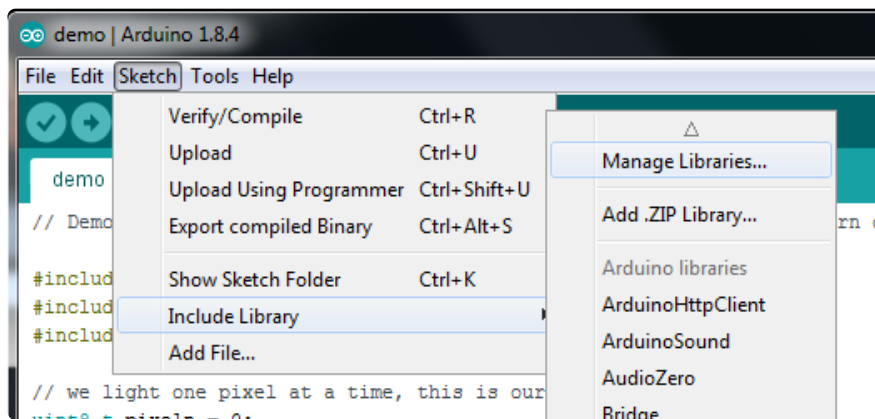

And type in **adafruit sgp30** to locate the library. Click **Install**

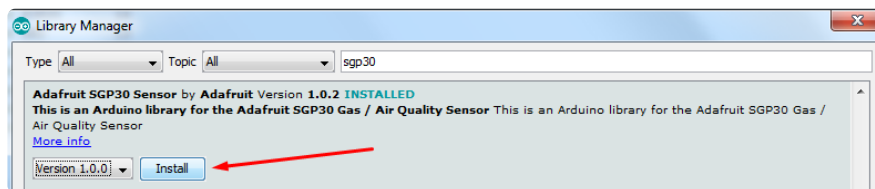

Load Demo

Open up **File->Examples->Adafruit_SGP30->sgp30test** and upload to your microcontroller wired up to the sensor

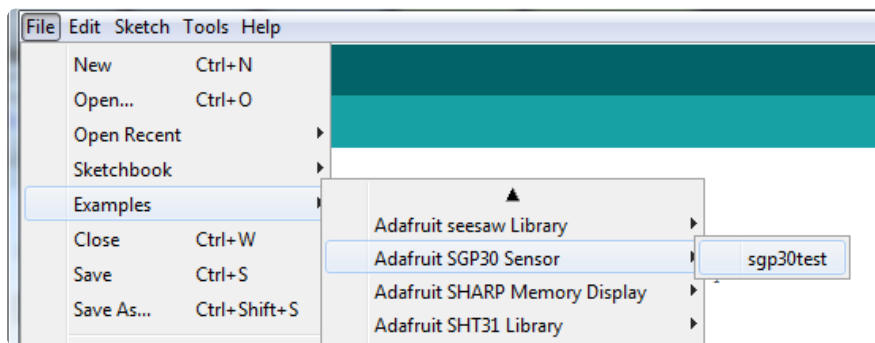

Then open up the serial console at **115200 baud**, you'll see the **serial number** printed out - this is a unique 48-bit number burned into each chip. Since you may want to do per-chip calibration, this can help keep your calibration detail separate

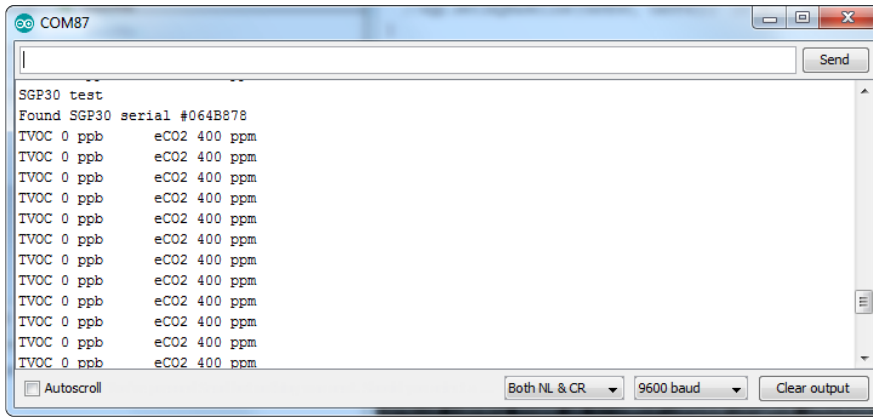

The first 10-20 readings will always be **TVOC 0 ppb eCO2 400 ppm**. That's because the sensor is warming up, so it will have 'null' readings.

After a few seconds, you will see the TVOC and eCO2 readings fluctuate:

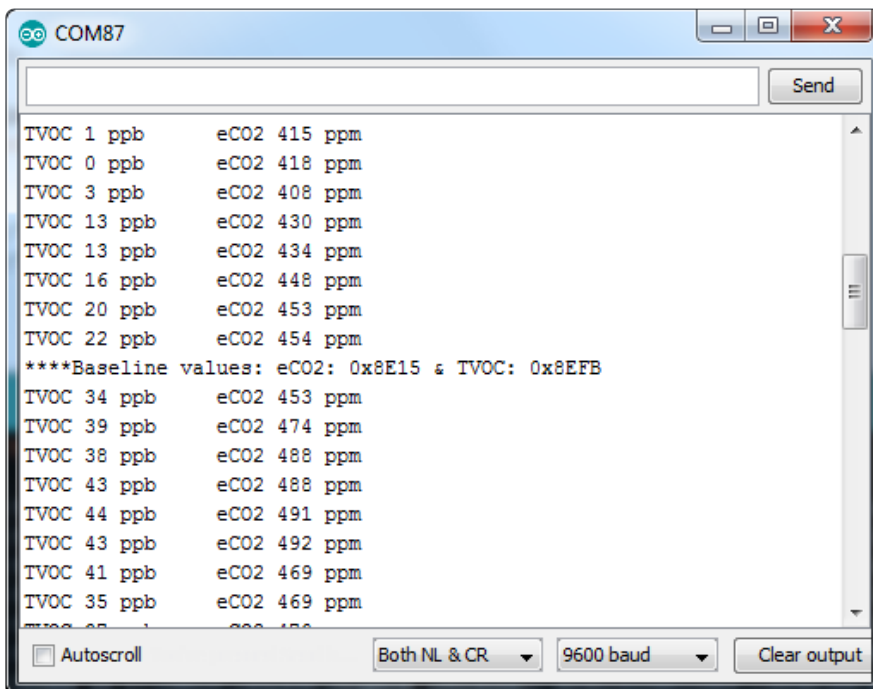

Every minute or so you'll also get a **Baseline value** printed out. More about that later!

You can take a bit of alcohol on a swap and swipe it nearby to get the readings to spike

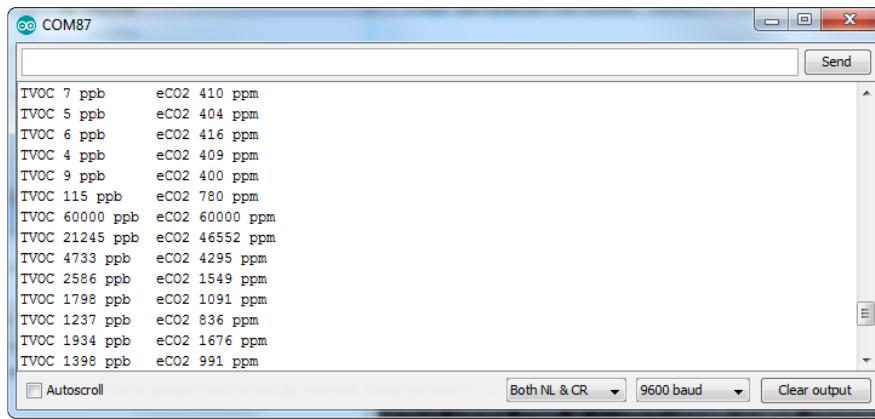

That's it! The sensor pretty much only does that - all the calculations for the TVOC and eCO2 are done within the sensor itself, no other data is exposed beyond the 'baseline' values

Baseline Set & Get

All VOC/gas sensors use the same underlying technology: a tin oxide element that, when exposed to organic compounds, changes resistance. The 'problem' with these sensors is that the baseline changes, often with humidity, temperature, and other non-gas-related-events. To keep the values coming out reasonable, you'll need to calibrate the sensor.

If no stored baseline is available after initializing the baseline algorithm, the sensor has to run for 12 hours until the baseline can be stored. This will ensure an optimal behavior for the next time it starts up. Reading out the baseline prior should be avoided unless a valid baseline is restored first. Once the baseline is properly initialized or restored, the current baseline value should be stored approximately once per hour. While the sensor is off, baseline values are valid for a maximum of seven days.

Restarting the sensor without reading back a previously stored baseline will result in the sensor trying to determine a new baseline. The adjustment algorithm will be accelerated for 12hrs which is the Maximum time required to find a new baseline.

The sensor adjusts to the best value it has been exposed to. So keeping it indoors the sensor thinks this is the best value and sets it to ~0ppb tVOC and 400ppm CO2eq. As soon as you expose the sensor to outside air it can adjust to the global H2 Background Signal. For normal Operation exposing the sensor to outside air for 10min cumulative time should be sufficient.

If you're experienced with sensors that don't have a baseline, you either won't be able to measure absolute values or you'll have to implement your own baseline algorithm.

The sensor to sensor variation of SGP30 in terms of sensitivity is very good as each of them is calibrated. But the baseline has to be determined for each sensor individually during the first Operation.

To make that easy, SGP lets you query the 'baseline calibration readings' from the sensor with code like this:

```
uint16_t TVOC_base, eCO2_base;
sgp.getIAQBaseline(&eCO2_base, &TVOC_base);
```

This will grab the two 16-bit sensor calibration words and place them in the variables so-named.

You should store these in EEPROM, FLASH or hard-coded. Then, next time you start up the sensor, you can pre-fill the calibration words with

```
sgp.setIAQBaseline(eCO2_baseline, TVOC_baseline);
```

Arduino Library Docs

[Arduino Library Docs \(https://adafru.it/AuL\)](https://adafru.it/AuL)

Python & CircuitPython Test

It's easy to use the SGP30 sensor with Python or CircuitPython and the [Adafruit CircuitPython SGP30 \(https://adafru.it/Bn-\)](https://adafru.it/Bn-) module. This module allows you to easily write Python code that reads the TVOC, eCO2, and more from the sensor.

You can use this sensor with any CircuitPython microcontroller board or with a computer that has GPIO and Python [thanks to Adafruit_Blinka, our CircuitPython-for-Python compatibility library \(https://adafru.it/BSN\)](https://adafru.it/BSN).

CircuitPython MicroController Wiring

Connect the SGP30 breakout to your board using an I2C connection, exactly as shown on the previous page for Arduino. Here's an example with a Feather M0:

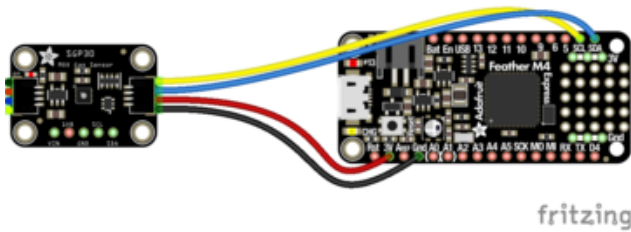

fritzing

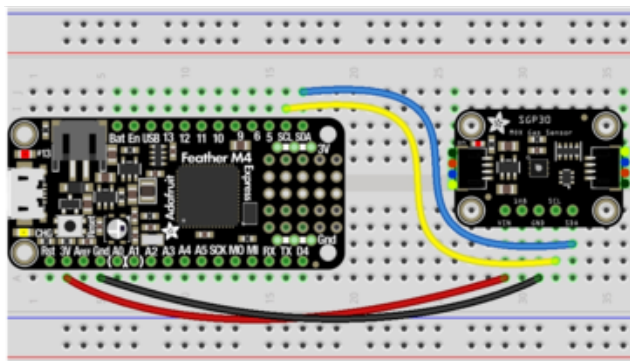

Board 3.3V to sensor Vin (red wire on STEMMA QT version) (Feather is 3.3V logic)

Board ground / GND to sensor ground / GND (black wire on STEMMA QT version).
Board SCL to sensor SCL (yellow wire on STEMMA QT version).

Board SDA to sensor SDA (blue wire on STEMMA QT version).

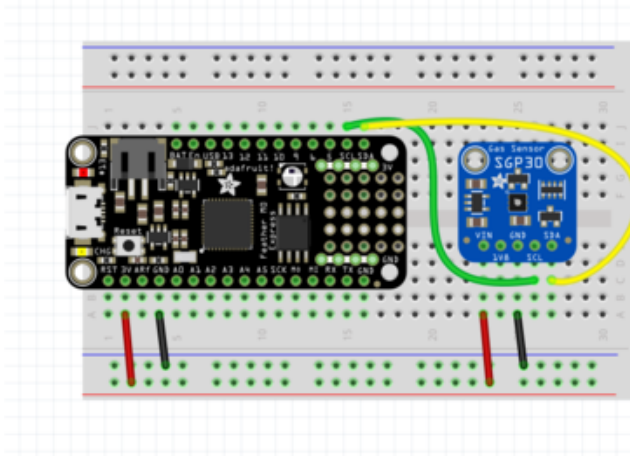

Feather Original Fritzing file

<https://adafru.it/At8>

Python Computer Wiring

Since there's dozens of Linux computers/boards you can use we will show wiring for Raspberry Pi. For other platforms, [please visit the guide for CircuitPython on Linux to see whether your platform is supported \(https://adafru.it/BSN\)](https://adafru.it/BSN).

Here's the Raspberry Pi wired with I2C:

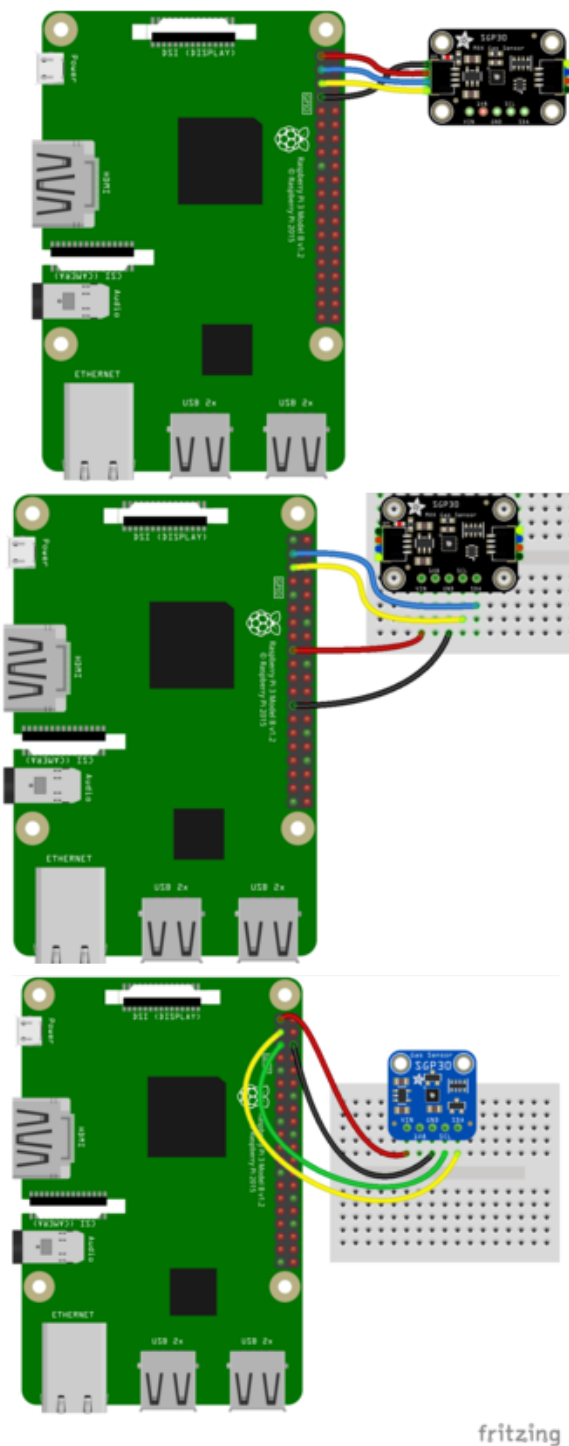

Pi 3V3 to sensor VIN (red wire on STEMMA QT version)
Pi GND to sensor GND (black wire on STEMMA QT version)
Pi SCL to sensor SCL (yellow wire on STEMMA QT version)
Pi SDA to sensor SDA (blue wire on STEMMA QT version)

CircuitPython Installation of SGP30 Library

To use the SGP30 you'll need to install the [Adafruit CircuitPython SGP30 \(https://adafru.it/Bn-\)](https://adafru.it/Bn-) library on your CircuitPython board.

First make sure you are running the [latest version of Adafruit CircuitPython \(https://adafru.it/Amd\)](https://adafru.it/Amd) for your board.

Next you'll need to install the necessary libraries to use the hardware--carefully follow the steps to find and install these libraries from [Adafruit's CircuitPython library bundle \(https://adafru.it/zdx\)](https://adafru.it/zdx). Our introduction guide has [a great page on how to install the library bundle \(https://adafru.it/ABU\)](https://adafru.it/ABU) for both express and non-express boards.

Remember for non-express boards like the, you'll need to manually install the necessary libraries from the bundle:

- `adafruit_sgp30.mpy`
- `adafruit_bus_device`

You can also download the `adafruit_sgp.mpy` from [its releases page on Github \(https://adafru.it/Bo0\)](https://adafru.it/Bo0).

Before continuing make sure your board's lib folder or root filesystem has the `adafruit_sgp30.mpy`, and `adafruit_bus_device` files and folders copied over.

Next [connect to the board's serial REPL \(https://adafru.it/Awz\)](https://adafru.it/Awz) so you are at the CircuitPython >>> prompt.

Python Installation of SGP30 Library

You'll need to install the Adafruit_Blinka library that provides the CircuitPython support in Python. This may also require enabling I2C on your platform and verifying you are running Python 3. [Since each platform is a little different, and Linux changes often, please visit the CircuitPython on Linux guide to get your computer ready \(https://adafru.it/BSN\)](https://adafru.it/BSN)!

Once that's done, from your command line run the following command:

- `sudo pip3 install adafruit-circuitpython-sgp30`

If your default Python is version 3 you may need to run 'pip' instead. Just make sure you aren't trying to use CircuitPython on Python 2.x, it isn't supported!

CircuitPython & Python Usage

To demonstrate the usage of the sensor we'll initialize it and read the eCO2 and TVOC data and print it to the REPL

Save this example sketch as **main.py** on your CircuitPython board:

```
# SPDX-FileCopyrightText: 2021 ladyada for Adafruit Industries
# SPDX-License-Identifier: MIT

""" Example for using the SGP30 with CircuitPython and the Adafruit library"""

import time
import board
import busio
import adafruit_sgp30

i2c = busio.I2C(board.SCL, board.SDA, frequency=100000)

# Create library object on our I2C port
sgp30 = adafruit_sgp30.Adafruit_SGP30(i2c)

print("SGP30 serial #", [hex(i) for i in sgp30.serial])

sgp30.set_iaq_baseline(0x8973, 0x8AAE)
sgp30.set_iaq_relative_humidity(celsius=22.1, relative_humidity=44)

elapsed_sec = 0

while True:
    print("eCO2 = %d ppm \t TVOC = %d ppb" % (sgp30.eCO2, sgp30.TVOC))
    time.sleep(1)
    elapsed_sec += 1
    if elapsed_sec > 10:
        elapsed_sec = 0
        print(
            "**** Baseline values: eCO2 = 0x%x, TVOC = 0x%x"
            % (sgp30.baseline_eCO2, sgp30.baseline_TVOC)
        )
```

In the REPL you'll see the **serial number** printed out: **[0x0, 0x64, 0xb878]** in this case. This is a unique 48-bit number burned into each chip. Since you may want to do per-chip calibration, this can help keep your calibration detail separate

gas-related-events. To keep the values coming out reasonable, you'll need to calibrate the sensor.

If no stored baseline is available after initializing the baseline algorithm, the sensor has to run for 12 hours until the baseline can be stored. This will ensure an optimal behavior for preceding startups. Reading out the baseline prior should be avoided unless a valid baseline is restored first. Once the baseline is properly initialized or restored, the current baseline value should be stored approximately once per hour. While the sensor is off, baseline values are valid for a maximum of seven days.

Restarting the sensor without reading back a previously stored baseline will result in the sensor trying to determine a new baseline. The adjustment algorithm will be accelerated for 12hrs which is the Maximum time required to find a new baseline.

The sensor adjusts to the best value it has been exposed to. So keeping it indoors the sensor thinks this is the best value and sets it to ~0ppb tVOC and 400ppm CO₂eq. As soon as you expose the sensor to outside air it can adjust to the global H₂ Background Signal. For normal Operation exposing the sensor to outside air for 10min cumulative time should be sufficient.

If you're experienced with sensors that don't have a baseline, you either won't be able to measure absolute values or you'll have to implement your own baseline algorithm.

The sensor to sensor variation of SGP30 in terms of sensitivity is very good as each of them is calibrated. But the baseline has to be determined for each sensor individually during the first Operation.

To make that easy, SGP lets you query the 'baseline calibration readings' from the sensor with code like this:

```
co2eq_base, tvoc_base = sgp30.baseline_co2eq, sgp30.baseline_tvoc
```

This will grab the two 16-bit sensor calibration words and place them in the variables so-named.

You should store these in EEPROM, FLASH or hard-coded. Then, next time you start up the sensor, you can pre-fill the calibration words with `sgp30.set_iaq_baseline(co2eq_base, tvoc_base)`

Python Library Docs

[Python Library Docs \(https://adafru.it/C3c\)](https://adafru.it/C3c)

WipperSnapper

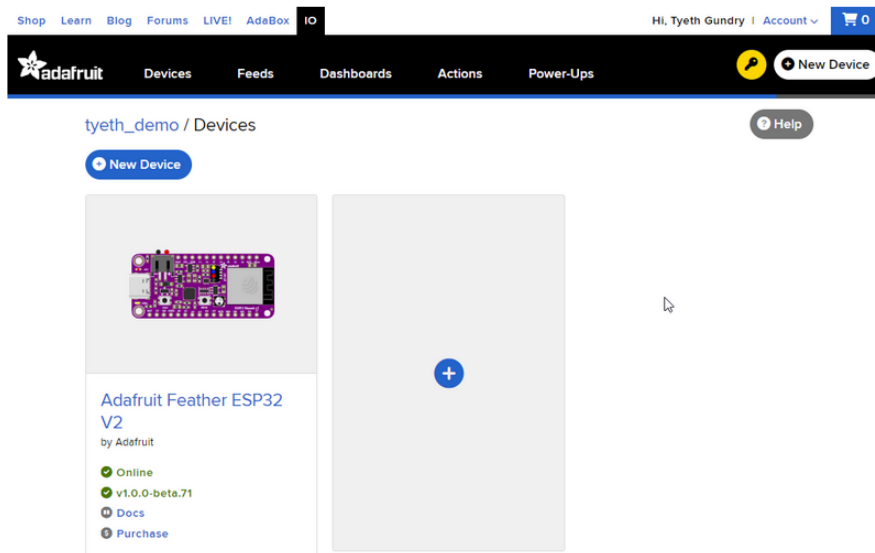

What is WipperSnapper

WipperSnapper is a firmware designed to turn any WiFi-capable board into an Internet-of-Things device without programming a single line of code. WipperSnapper connects to [Adafruit IO \(https://adafru.it/fsU\)](https://adafru.it/fsU), a web platform designed ([by Adafruit! \(https://adafru.it/Bo5\)](https://adafru.it/Bo5)) to display, respond, and interact with your project's data.

Simply load the WipperSnapper firmware onto your board, add credentials, and plug it into power. Your board will automatically register itself with your Adafruit IO account.

From there, you can add components to your board such as buttons, switches, potentiometers, sensors, and more! Components are dynamically added to hardware, so you can immediately start interacting, logging, and streaming the data your projects produce without writing code.

If you've never used WipperSnapper, click below to read through the quick start guide before continuing.

Quickstart: Adafruit IO WipperSnapper

<https://adafru.it/Vfd>

Wiring

First, wire up an SGP-30 to your board exactly as follows. Here is an example of the SGP-30 wired to an [Adafruit ESP32 Feather V2](http://adafru.it/5400) (<http://adafru.it/5400>) using I2C [with a STEMMA QT cable](http://adafru.it/4210) (no soldering required) (<http://adafru.it/4210>)

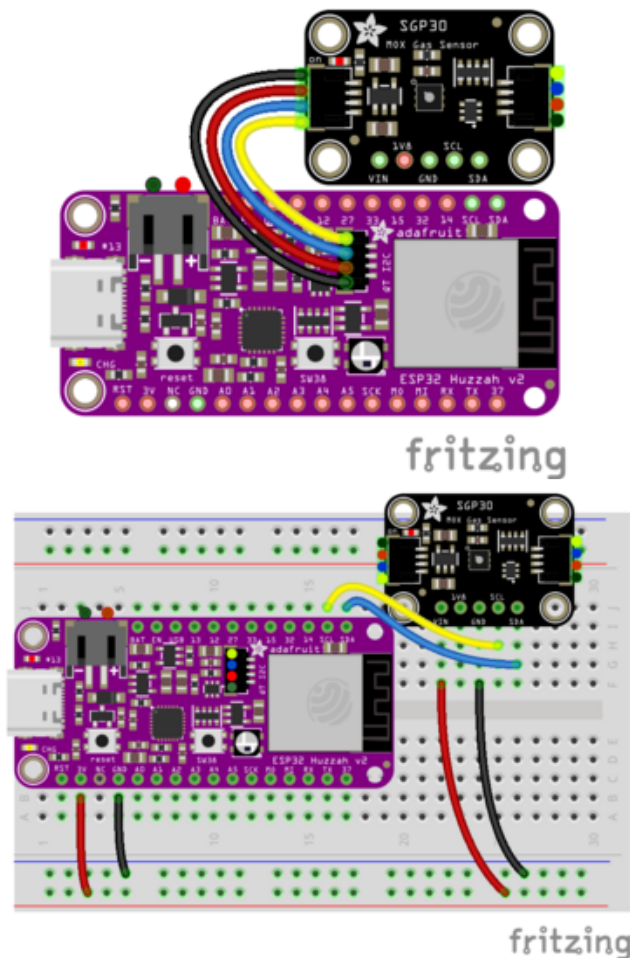

Board 3V to sensor VIN (red wire on STEMMA QT)

Board GND to sensor GND (black wire on STEMMA QT)

Board SCL to sensor SCL (yellow wire on STEMMA QT)

Board SDA to sensor SDA (blue wire on STEMMA QT)

Usage

Connect your board to Adafruit IO Wippersnapper and [navigate to the WipperSnapper board list](https://adafru.it/TAu) (<https://adafru.it/TAu>).

On this page, select the WipperSnapper board you're using to be brought to the board's interface page.

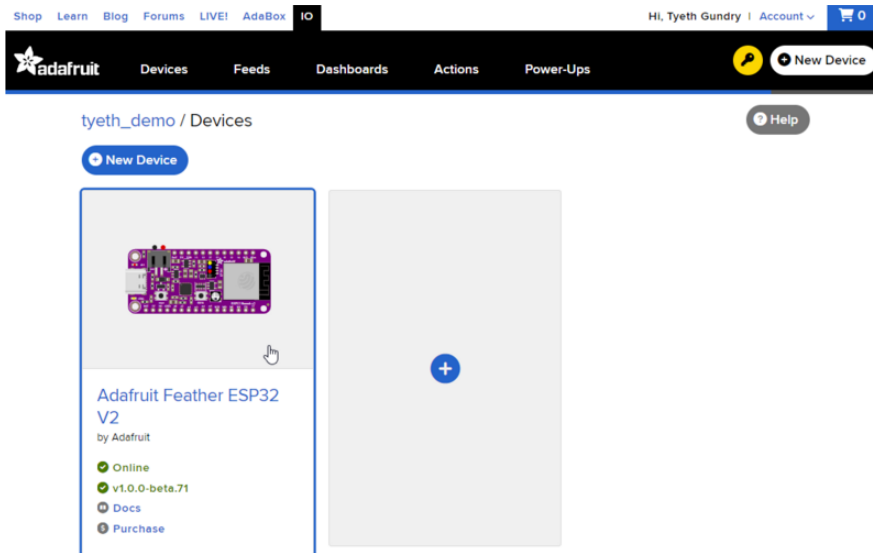

If you do not see your board listed here - you need [to connect your board to Adafruit IO](https://adafru.it/Vfd) first.



On the device page, quickly check that you're running the latest version of the WipperSnapper firmware.

The device tile on the left indicates the version number of the firmware running on the connected board.

If the firmware version is green with a checkmark - continue with this guide. If the firmware version is red with an exclamation mark "!" - [update to the latest WipperSnapper firmware](https://adafru.it/Vfd) before continuing.

Next, make sure the sensor is plugged into your board and click the **I2C Scan** button.

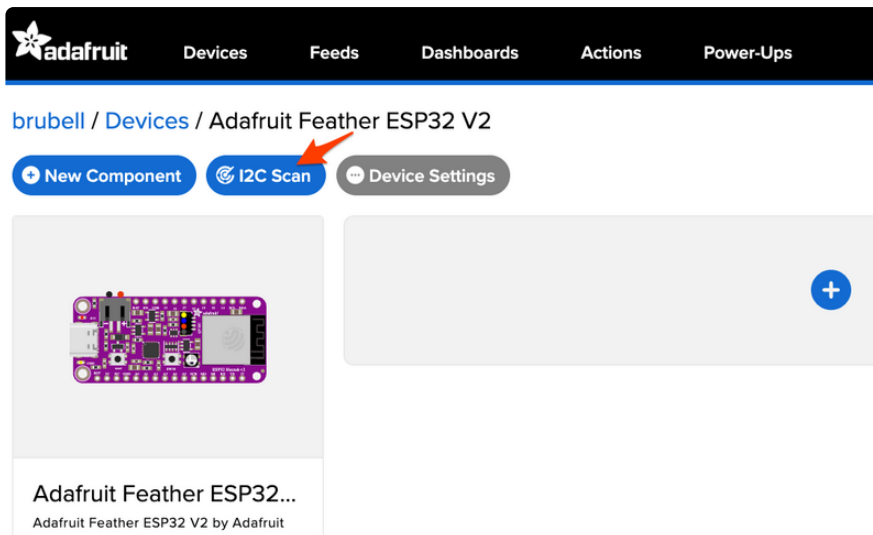

You should see the SGP30's default I2C address of `0x58` pop-up in the I2C scan list.

I2C Scan Complete ✕

	0	1	2	3	4	5	6	7	8	9	a	b	c	d	e	f
00								--	--	--	--	--	--	--	--	--
10	--	--	--	--	--	--	--	--	--	--	--	--	--	--	--	--
20	--	--	--	--	--	--	--	--	--	--	--	--	--	--	--	--
30	--	--	--	--	--	--	--	--	--	--	--	--	--	--	--	--
40	--	--	--	--	--	--	--	--	--	--	--	--	--	--	--	--
50	--	--	--	--	--	--	--	--	58	--	--	--	--	--	--	--
60	--	--	--	--	--	--	--	--	--	--	--	--	--	--	--	--
70	--	--	--	--	--	--	--	--	--	--	--	--	--	--	--	--

Close
Scan Again

I don't see the sensor's I2C address listed!

First, double-check the connection and/or wiring between the sensor and the board.

Then, reset the board and let it re-connect to Adafruit IO WipperSnapper.

With the sensor detected in an I2C scan, you're ready to add the sensor to your board.

Click the **New Component** button or the **+ button** to bring up the component picker.



Adafruit IO supports a large amount of components. To quickly find your sensor, type **SGP30** into the search bar, then select the **SGP30** component.

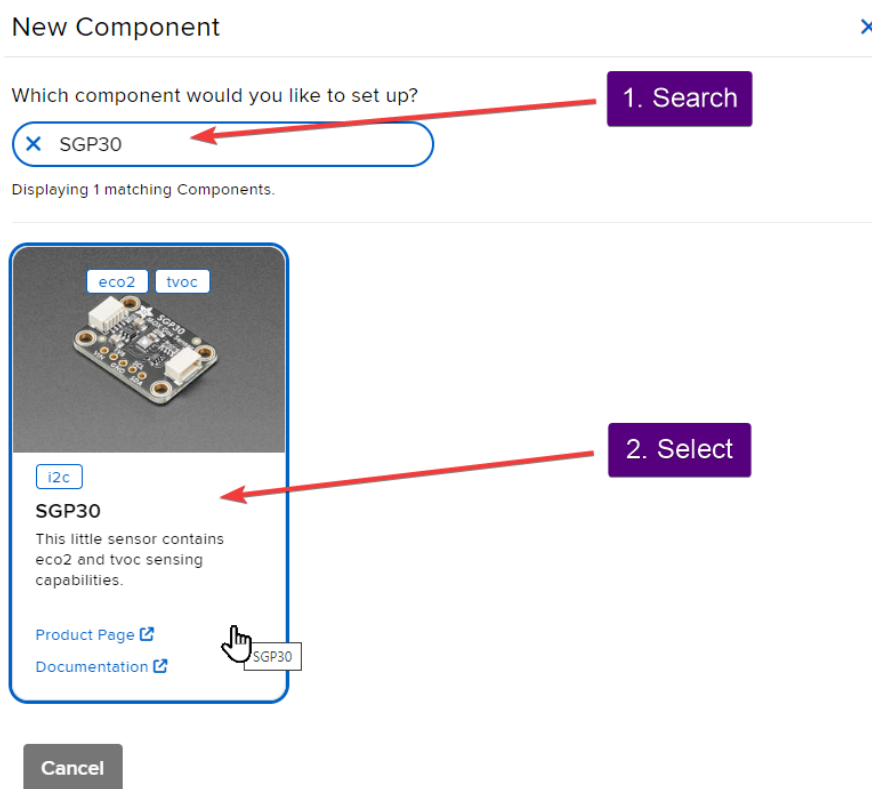

On the component configuration page, the SGP30's sensor address should be listed along with the sensor's settings.

The **Send Every** option is specific to each sensor's measurements. This option will tell the Feather how often it should read from the SGP30 sensor and send the data to Adafruit IO. Measurements can range from every 30 seconds to every 24 hours.

For this example, set the **Send Every** interval to every 30 seconds.

Create SGP30 Component



Select I2C Address:

0x58

Enable SGP30: Estimated CO2?

Name:

SGP30: Estimated CO2

Send Data:

Every 30 seconds

Enable SGP30: Total Volatile Organic Compounds?

Name:

SGP30: Total Volatile Organic Compounds

Send Data:

Every 30 seconds

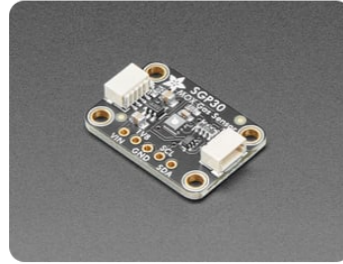

[← Back to Component Type](#)

Create Component

Your device interface should now show the sensor components you created. After the interval you configured elapses, WipperSnapper will automatically read values from the sensor(s) and send them to Adafruit IO.

Note that the SGP30 takes approximately 20minutes to settle after power-up before reliable readings are given. The first 40 readings will always be **eCO2 400 ppm** and **TVOC 0 ppb**. That's because the sensor is warming up, so it will have 'null' readings.

There is also a one-time initial 48hour burn-in period when fresh from the factory / powered for the first time. The sensor will not give reliable reading during this period.

The screenshot shows the Adafruit IO dashboard for a device named 'tyeth_demo'. The navigation bar includes 'Shop', 'Learn', 'Blog', 'Forums', 'LIVE!', 'AdaBox', and 'IO'. The user is logged in as 'Hi, Tyeth Gundry'. The main navigation includes 'Devices', 'Feeds', 'Dashboards', 'Actions', 'Power-Ups', and a '+ New Device' button. The current view is 'tyeth_demo / Devices / Adafruit Feather ESP32 V2'. There are buttons for 'New Component', 'Auto-Config', 'I2C Scan', 'Help', and 'Settings'. Two sensor components are visible: 'SGP30: Estimated CO2' (sgp30.eco2) showing a value of 400.00ppm, and 'SGP30: Total Volatile Organic Compounds' (sgp30.tvoc) showing a value of TVOC: 0.00 ppb. A '+ New Component' button is at the bottom.

After a few seconds, once the sensor has warmed up, you will see the TVOC and eCO2 readings fluctuate

To view the data that has been logged from the sensor, click on the graph next to the sensor name.

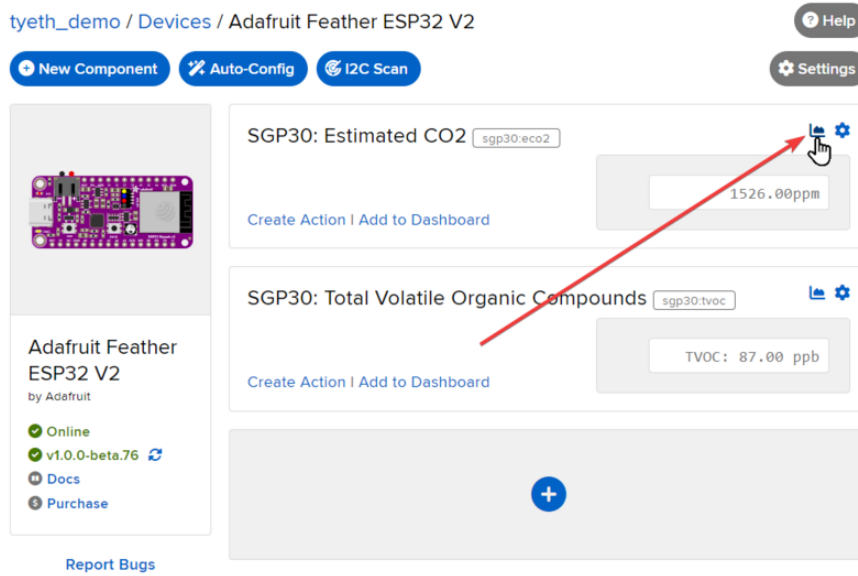

Here you can see the feed history and edit things about the feed such as the name, privacy, webhooks associated with the feed and more. If you want to learn more about how feeds work, [check out this page \(https://adafru.it/10aZ\)](https://adafru.it/10aZ).

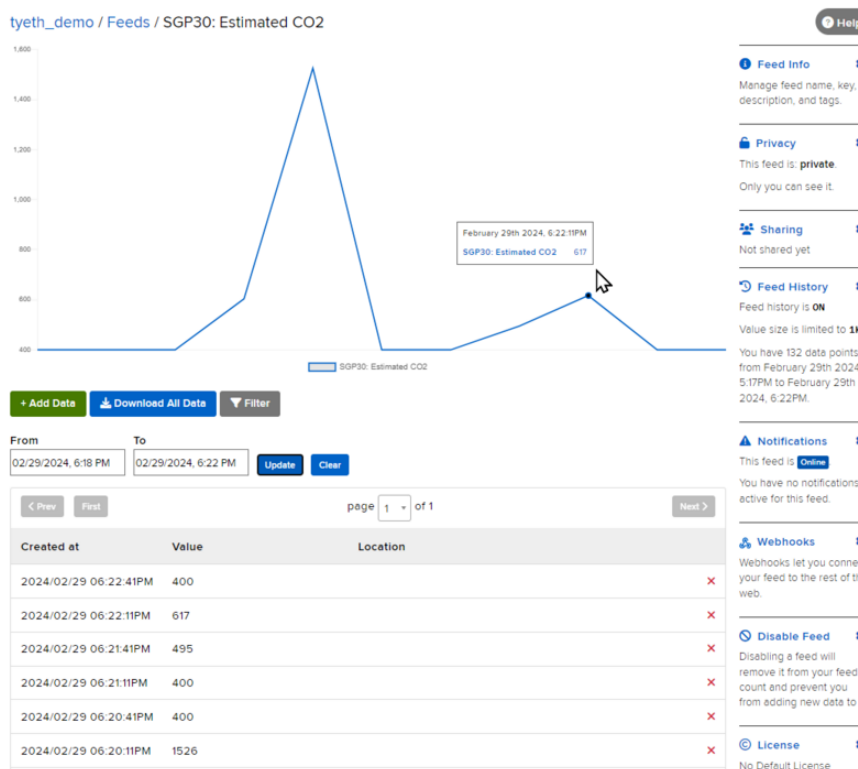

Download

Files:

- [SGP30 Datasheet \(https://adafru.it/Bo1\)](https://adafru.it/Bo1)
- [Fritzing object in Adafruit Fritzing library \(https://adafru.it/aP3\)](https://adafru.it/aP3)
- [EagleCAD files on GitHub \(https://adafru.it/Lle\)](https://adafru.it/Lle)

Schematic STEMMA QT Version

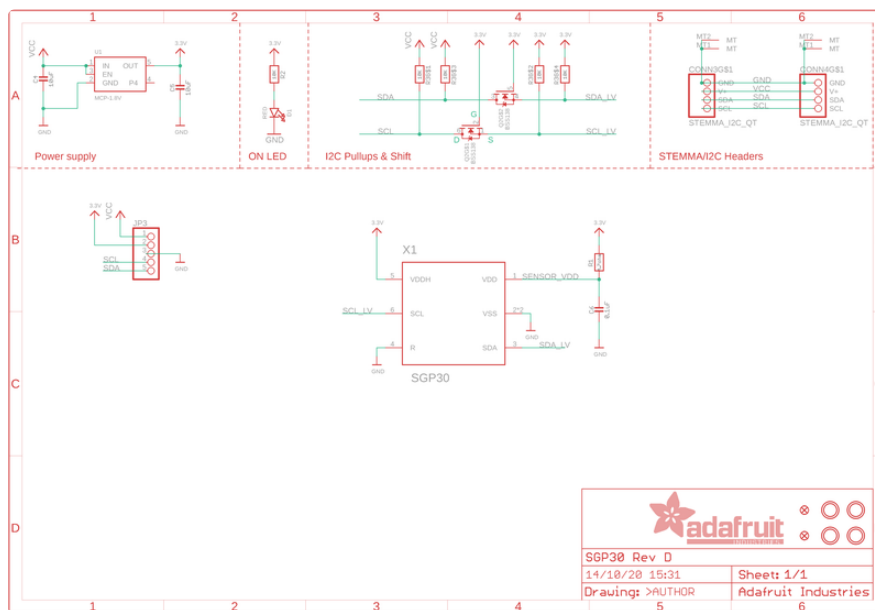

Fabrication Print STEMMMA QT Version

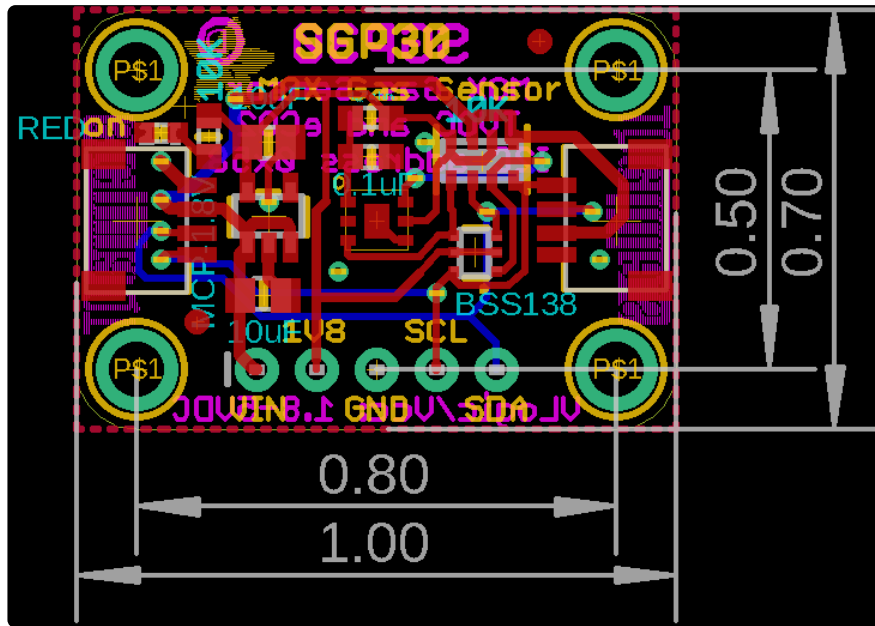

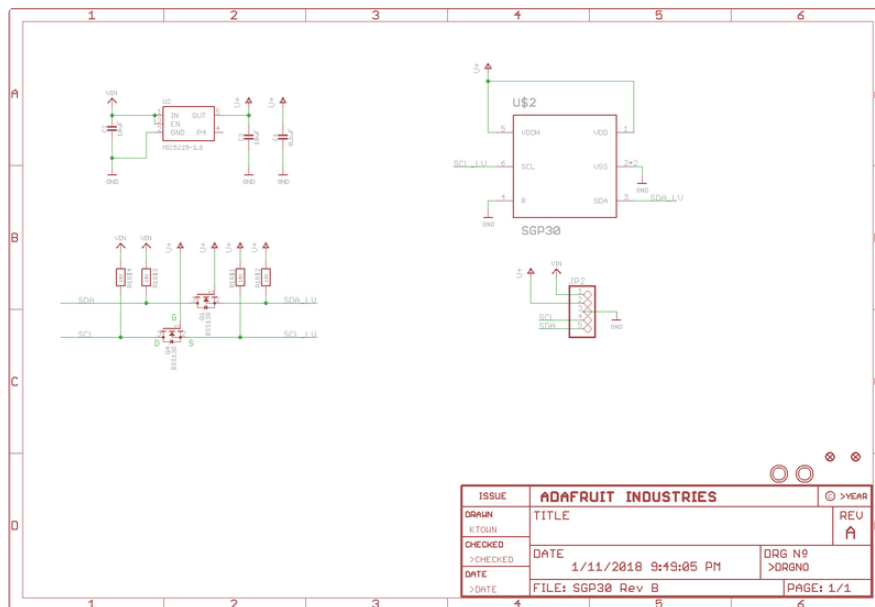

Schematic & Fabrication Print Original Version

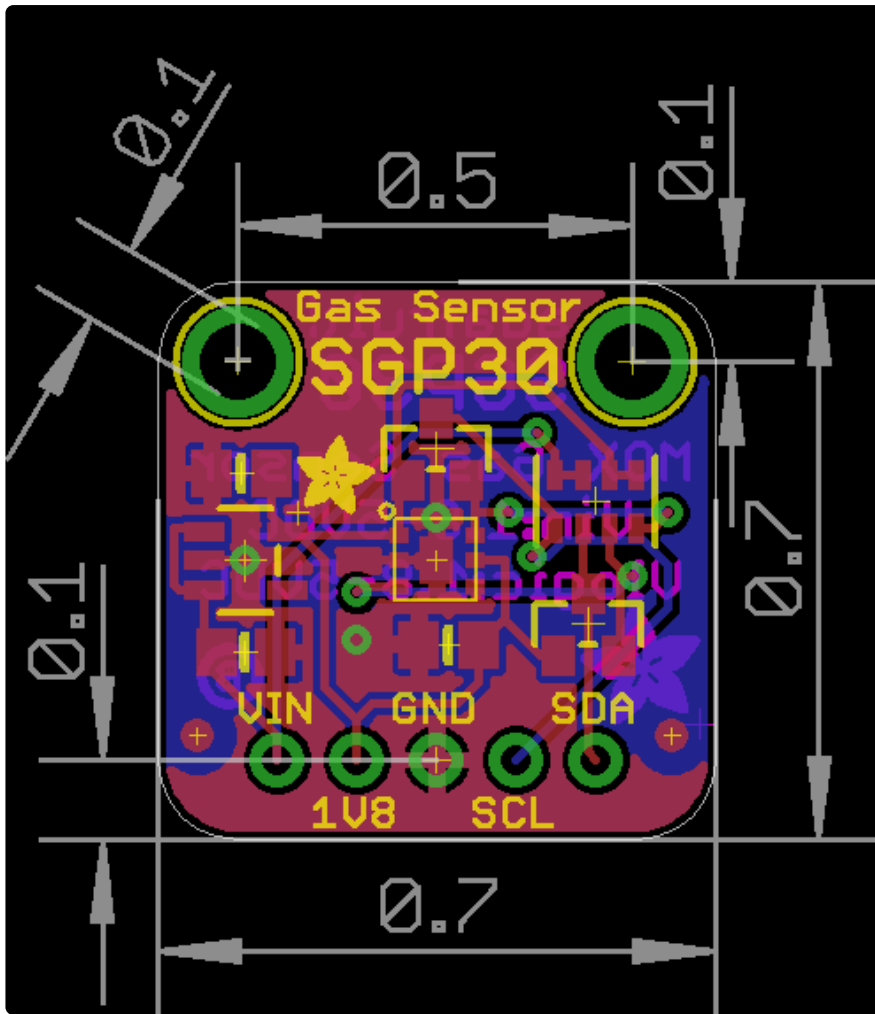







Looking for pricing, stock, or lifecycle information?

Click below to explore more details on WIN SOURCE:

-  [View 3709 on WIN SOURCE](#)
-  [Adafruit Industries LLC Information](#)

Optimize Your Supply Chain with WIN SOURCE Solutions

-  Global Sourcing Solution
-  Obsolete Management
-  Cost Control Management
-  Shortage Management
-  Alternative Solution
-  Excess Inventory Management