



**THE DATASHEET OF  
SN65LVDS180PWRQ1**



## HIGH-SPEED DIFFERENTIAL LINE DRIVERS AND RECEIVERS

Check for Samples: [SN65LVDS180-Q1](#), [SN65LVDS050-Q1](#), [SN65LVDS051-Q1](#)

### FEATURES

- Qualified for Automotive Applications
- ESD Protection Exceeds 2000 V Per MIL-STD-883, Method 3015; Exceeds 200 V Using Machine Model (C = 200 pF, R = 0)
- Meets or Exceeds the Requirements of ANSI TIA/EIA-644-1995 Standard
- Signaling Rates up to 400 Mbps
- Bus-Terminal ESD Exceeds 12 kV
- Operates From a Single 3.3-V Supply
- Low-Voltage Differential Signaling With Typical Output Voltages of 350 mV and a 100-Ω Load
- Propagation Delay Times
  - Driver: 1.7 ns Typ
  - Receiver: 3.7 ns Typ
- Power Dissipation at 200 MHz
  - Driver: 25 mW Typical
  - Receiver: 60 mW Typical
- LVTTTL Input Levels Are 5-V Tolerant
- Receiver Maintains High Input Impedance With  $V_{CC} < 1.5$  V
- Receiver Has Open-Circuit Fail Safe

### DESCRIPTION

The SN65LVDS180, SN65LVDS050, and SN65LVDS051 are differential line drivers and receivers that use low-voltage differential signaling (LVDS) to achieve signaling rates as high as 400 Mbps. The TIA/EIA-644 standard compliant electrical interface provides a minimum differential output voltage magnitude of 247 mV into a 100-Ω load and receipt of 50-mV signals with up to 1 V of ground potential difference between a transmitter and receiver.

The intended application of this device and signaling technique is for point-to-point baseband data transmission over controlled impedance media of approximately 100-Ω characteristic impedance. The transmission media may be printed-circuit board traces, backplanes, or cables. (Note: The ultimate rate and distance of data transfer is dependent upon the attenuation characteristics of the media, the noise coupling to the environment, and other application specific characteristics).

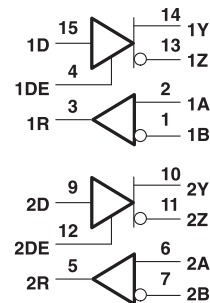
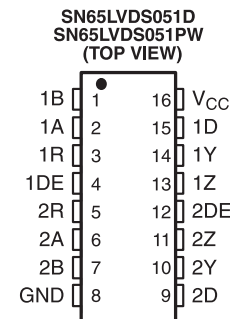
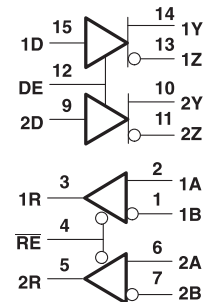
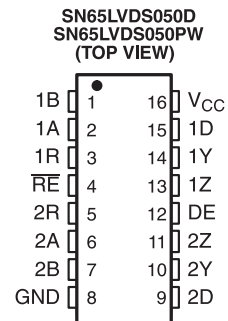
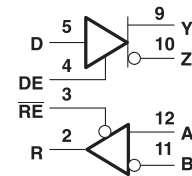
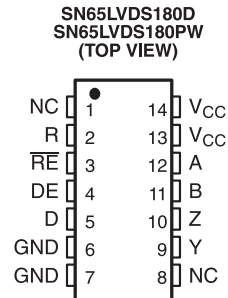

Please be aware that an important notice concerning availability, standard warranty, and use in critical applications of Texas Instruments semiconductor products and disclaimers thereto appears at the end of this data sheet.



These devices have limited built-in ESD protection. The leads should be shorted together or the device placed in conductive foam during storage or handling to prevent electrostatic damage to the MOS gates.

## DESCRIPTION (CONTINUED)

The devices offer various driver, receiver, and enabling combinations in industry standard footprints. Since these devices are intended for use in simplex or distributed simplex bus structures, the driver enable function does not put the differential outputs into a high-impedance state but rather disconnects the input and reduces the quiescent power used by the device. (For these functions with a high-impedance driver output, see the SN65LVDM series of devices.) All devices are characterized for operation from  $-40^{\circ}\text{C}$  to  $85^{\circ}\text{C}$ .

### ORDERING INFORMATION<sup>(1)</sup>

$T_A$	PACKAGE <sup>(2)</sup>		ORDERABLE PART NUMBER	TOP-SIDE MARKING
$-40^{\circ}\text{C}$ to $85^{\circ}\text{C}$	SOIC (D)	Tape and reel	SN65LVDS180DRQ1	VDS180Q
	TSSOP (PW)	Tape and reel	SN65LVDS180PWRQ1	VDS180Q
	SOIC (D)	Tape and reel	SN65LVDS050DRQ1 <sup>(3)</sup>	VDS050Q
	TSSOP (PW)	Tape and reel	SN65LVDS050IPWRQ1	VDS050Q
	SOIC (D)	Tape and reel	SN65LVDS051DRQ1	VDS051Q
	TSSOP (PW)	Tape and reel	SN65LVDS051PWRQ1	VDS051Q

- (1) For the most current package and ordering information, see the Package Option Addendum at the end of this document, or see the TI web site at [www.ti.com](http://www.ti.com).  
 (2) Package drawings, thermal data, and symbolization are available at [www.ti.com/packaging](http://www.ti.com/packaging).  
 (3) Product Preview

## FUNCTION TABLES

### SN65LVDS180, SN65LVDS050, and SN65LVDS051 RECEIVER<sup>(1)</sup>

INPUTS		OUTPUT
$V_{ID} = V_A - V_B$	$\overline{RE}$	R
$V_{ID} \geq 50\text{ mV}$	L	H
$-50\text{ mV} < V_{ID} < 50\text{ mV}$	L	?
$V_{ID} \leq -50\text{ mV}$	L	L
Open	L	H
X	H	Z

- (1) H = high level, L = low level, Z = high impedance, X = don't care, ? = indeterminate

### SN65LVDS180, SN65LVDS050, and SN65LVDS051 DRIVER<sup>(1)</sup>

INPUTS		OUTPUTS	
D	DE	Y	Z
L	H	L	H
H	H	H	L
Open	H	L	H
X	L	OFF	OFF

- (1) H = high level, L = low level, Z = high impedance, X = don't care, OFF = no output

**EQUIVALENT INPUT AND OUTPUT SCHEMATIC DIAGRAMS**

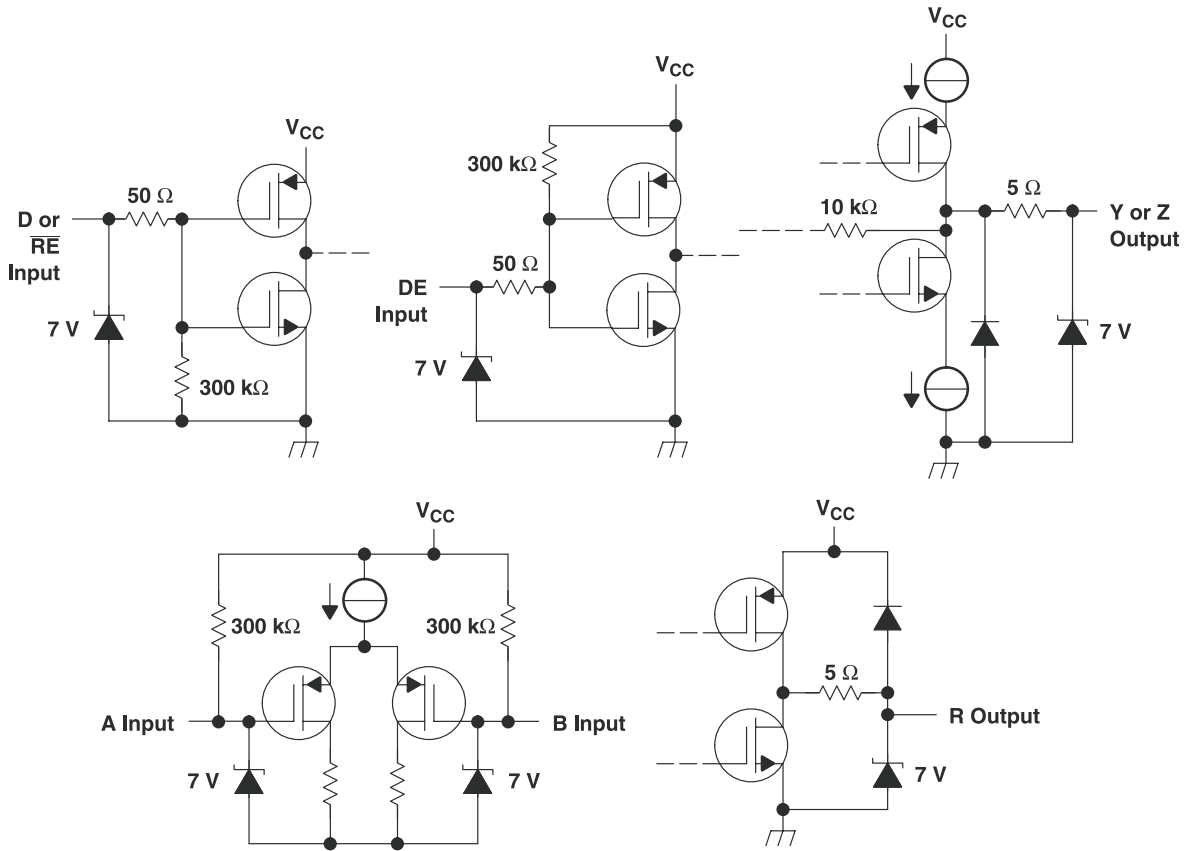

## ABSOLUTE MAXIMUM RATINGS<sup>(1)</sup>

over operating free-air temperature range (unless otherwise noted)

		UNIT
V <sub>CC</sub>	Supply voltage range <sup>(2)</sup>	–0.5 V to 4 V
Voltage range	D, R, DE, $\overline{RE}$	–0.5 V to 6 V
	Y, Z, A, and B	–0.5 V to 4 V
V <sub>OD</sub>	Differential output voltage	1 V
Electrostatic discharge	Y, Z, A, B, and GND (see <sup>(3)</sup> )	Class 3, A:12 kV, B:600 V
	All	Class 3, A:7 kV, B:500 V
Continuous power dissipation		See Dissipation Rating Table
Storage temperature range		–65°C to 150°C
Lead temperature 1,6 mm (1/16 inch) from case for 10 seconds		250°C

- (1) Stresses beyond those listed under absolute maximum ratings may cause permanent damage to the device. These are stress ratings only, and functional operation of the device at these or any other conditions beyond those indicated under recommended operating conditions is not implied. Exposure to absolute-maximum-rated conditions for extended periods may affect device reliability.
- (2) All voltage values, except differential I/O bus voltages are with respect to network ground terminal.
- (3) Tested in accordance with MIL-STD-883C Method 3015.7.

## DISSIPATION RATING TABLE

PACKAGE	T <sub>A</sub> ≤ 25°C POWER RATING	DERATING FACTOR ABOVE T <sub>A</sub> = 25°C <sup>(1)</sup>	T <sub>A</sub> = 85°C POWER RATING
PW(14)	736 mW	5.9 mW/°C	383 mW
PW(16)	839 mW	6.7 mW/°C	437 mW
D(8)	635 mW	5.1 mW/°C	330 mW/°C
D(14)	987 mW	7.9 mW/°C	513 mW/°C
D(16)	1110 mW	8.9 mW/°C	577 mW/°C

- (1) This is the inverse of the junction-to-ambient thermal resistance when board-mounted and with no airflow.

## RECOMMENDED OPERATING CONDITIONS

		MIN	NOM	MAX	UNIT
V <sub>CC</sub>	Supply voltage	3	3.3	3.6	V
V <sub>IH</sub>	High-level input voltage	2			V
V <sub>IL</sub>	Low-level input voltage			0.8	V
V <sub>ID</sub>	Magnitude of differential input voltage	0.1		0.6	V
V <sub>OD(dis)</sub>	Magnitude of differential output voltage with disabled driver			520	mV
V <sub>OY</sub> or V <sub>OZ</sub>	Driver output voltage	0		2.4	V
V <sub>IC</sub>	Common-mode input voltage (see <a href="#">Figure 5</a> )	$\frac{ V_{ID} }{2}$	2.4 – $\frac{ V_{ID} }{2}$	V <sub>CC</sub> – 0.8	V
T <sub>A</sub>	Operating free-air temperature	–40		85	°C

## DEVICE ELECTRICAL CHARACTERISTICS

over recommended operating conditions (unless otherwise noted)

PARAMETER		TEST CONDITIONS	MIN	TYP <sup>(1)</sup>	MAX	UNIT	
I <sub>CC</sub>	Supply current	SN65LVDS180	Driver and receiver enabled, no receiver load, driver R <sub>L</sub> = 100 Ω		9	12	mA
			Driver enabled, receiver disabled, R <sub>L</sub> = 100 Ω		5	7	
			Driver disabled, receiver enabled, no load		1.5	2	
			Disabled		0.5	1	
	SN65LVDS050	Drivers and receivers enabled, no receiver loads, driver R <sub>L</sub> = 100 Ω		12	20	mA	
		Drivers enabled, receivers disabled, R <sub>L</sub> = 100 Ω		10	16		
		Drivers disabled, receivers enabled, no loads		3	6		
		Disabled		0.5	1		
	SN65LVDS051	Drivers enabled, No receiver loads, driver R <sub>L</sub> = 100 Ω		12	20	mA	
		Drivers disabled, no loads		3	6		

(1) All typical values are at 25°C and with a 3.3-V supply.

## DRIVER ELECTRICAL CHARACTERISTICS

over recommended operating conditions (unless otherwise noted)

PARAMETER		TEST CONDITIONS	MIN	TYP	MAX	UNIT
V <sub>OD</sub>	Differential output voltage magnitude	R <sub>L</sub> = 100 Ω, See <a href="#">Figure 3</a> and <a href="#">Figure 2</a>	247	340	454	mV
Δ V <sub>OD</sub>	Change in differential output voltage magnitude between logic states		-50		50	
V <sub>OC(SS)</sub>	Steady-state common-mode output voltage	See <a href="#">Figure 3</a>	1.125	1.2	1.375	V
ΔV <sub>OC(SS)</sub>	Change in steady-state common-mode output voltage between logic states		-50		50	mV
V <sub>OC(PP)</sub>	Peak-to-peak common-mode output voltage		50		150	mV
I <sub>IH</sub>	High-level input current	DE	V <sub>IH</sub> = 5 V	-0.5	-20	μA
		D		2	20	
I <sub>IL</sub>	Low-level input current	DE	V <sub>IL</sub> = 0.8 V	-0.5	-10	μA
		D		2	10	
I <sub>OS</sub>	Short-circuit output current	V <sub>OY</sub> or V <sub>OZ</sub> = 0 V		3	10	mA
		V <sub>OD</sub> = 0 V		3	10	
I <sub>O(OFF)</sub>	Off-state output current	DE = 0V V <sub>OY</sub> = V <sub>OZ</sub> = 0V	-1		1	μA
		DE = V <sub>CC</sub> V <sub>OY</sub> = V <sub>OZ</sub> = 0V, V <sub>CC</sub> < 1.5 V				
C <sub>IN</sub>	Input capacitance			3		pF

## RECEIVER ELECTRICAL CHARACTERISTICS

over recommended operating conditions (unless otherwise noted)

PARAMETER		TEST CONDITIONS	MIN	TYP <sup>(1)</sup>	MAX	UNIT
V <sub>IT+</sub>	Positive-going differential input voltage threshold	See Figure 5 and			50	mV
V <sub>IT-</sub>	Negative-going differential input voltage threshold			-50		
V <sub>OH</sub>	High-level output voltage	I <sub>OH</sub> = -8 mA	2.4			V
		I <sub>OH</sub> = -4 mA	2.8			
V <sub>OL</sub>	Low-level output voltage	I <sub>OL</sub> = 8 mA			0.4	V
I <sub>I</sub>	Input current (A or B inputs)	V <sub>I</sub> = 0	-2	-11	-20	μA
		V <sub>I</sub> = 2.4 V	-1.2	-3		
I <sub>I(OFF)</sub>	Power-off input current (A or B inputs)	V <sub>CC</sub> = 0			±20	μA
I <sub>IH</sub>	High-level input current (enables)	V <sub>IH</sub> = 5 V			±10	μA
I <sub>IL</sub>	Low-level input current (enables)	V <sub>IL</sub> = 0.8 V			±10	μA
I <sub>OZ</sub>	High-impedance output current	V <sub>O</sub> = 0 or 5 V			±10	μA
C <sub>I</sub>	Input capacitance			5		pF

(1) All typical values are at 25°C and with a 3.3-V supply.

## DRIVER SWITCHING CHARACTERISTICS

over recommended operating conditions (unless otherwise noted)

PARAMETER		TEST CONDITIONS	MIN	TYP <sup>(1)</sup>	MAX	UNIT
t <sub>PLH</sub>	Propagation delay time, low-to-high-level output	R <sub>L</sub> = 100 Ω, C <sub>L</sub> = 10 pF, See Figure 2		1.7	2.7	ns
t <sub>PHL</sub>	Propagation delay time, high-to-low-level output			1.7	2.7	ns
t <sub>r</sub>	Differential output signal rise time			0.8	1	ns
t <sub>f</sub>	Differential output signal fall time			0.8	1	ns
t <sub>sk(p)</sub>	Pulse skew ( t <sub>pHL</sub> - t <sub>pLH</sub>  ) <sup>(2)</sup>			300		ps
t <sub>sk(o)</sub>	Channel-to-channel output skew <sup>(3)</sup>			150		ps
t <sub>en</sub>	Enable time	See Figure 4		4.3	10	ns
t <sub>dis</sub>	Disable time			3.1	10	ns

(1) All typical values are at 25°C and with a 3.3-V supply.

(2) t<sub>sk(p)</sub> is the magnitude of the time difference between the high-to-low and low-to-high propagation delay times at an output.

(3) t<sub>sk(o)</sub> is the magnitude of the time difference between the outputs of a single device with all of their inputs connected together.

## RECEIVER SWITCHING CHARACTERISTICS

over recommended operating conditions (unless otherwise noted)

PARAMETER		TEST CONDITIONS	MIN	TYP <sup>(1)</sup>	MAX	UNIT
t <sub>PLH</sub>	Propagation delay time, low-to-high-level output	C <sub>L</sub> = 10 pF, See Figure 6		3.7	4.5	ns
t <sub>PHL</sub>	Propagation delay time, high-to-low-level output			3.7	4.5	ns
t <sub>sk(p)</sub>	Pulse skew ( t <sub>pHL</sub> - t <sub>pLH</sub>  ) <sup>(2)</sup>			0.3		ns
t <sub>r</sub>	Output signal rise time	See Figure 7		0.7	1.5	ns
t <sub>f</sub>	Output signal fall time			0.9	1.5	ns
t <sub>PZH</sub>	Propagation delay time, high-impedance-to-high-level output			2.5		ns
t <sub>PZL</sub>	Propagation delay time, high-impedance-to-low-level output			2.5		ns
t <sub>PHZ</sub>	Propagation delay time, high-level-to-high-impedance output			7		ns
t <sub>PLZ</sub>	Propagation delay time, low-level-to-high-impedance output			4		ns

(1) All typical values are at 25°C and with a 3.3-V supply.

(2) t<sub>sk(p)</sub> is the magnitude of the time difference between the high-to-low and low-to-high propagation delay times at an output.

## PARAMETER MEASUREMENT INFORMATION

### DRIVER

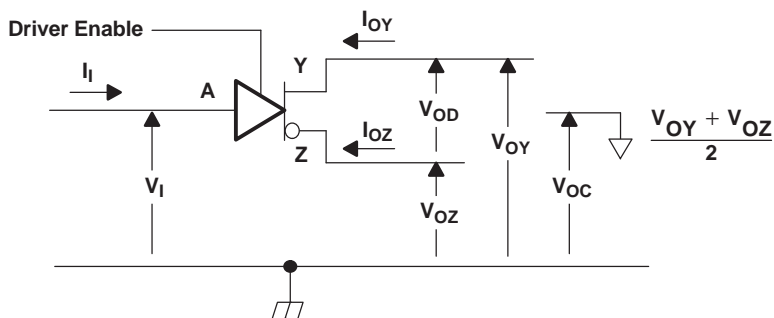
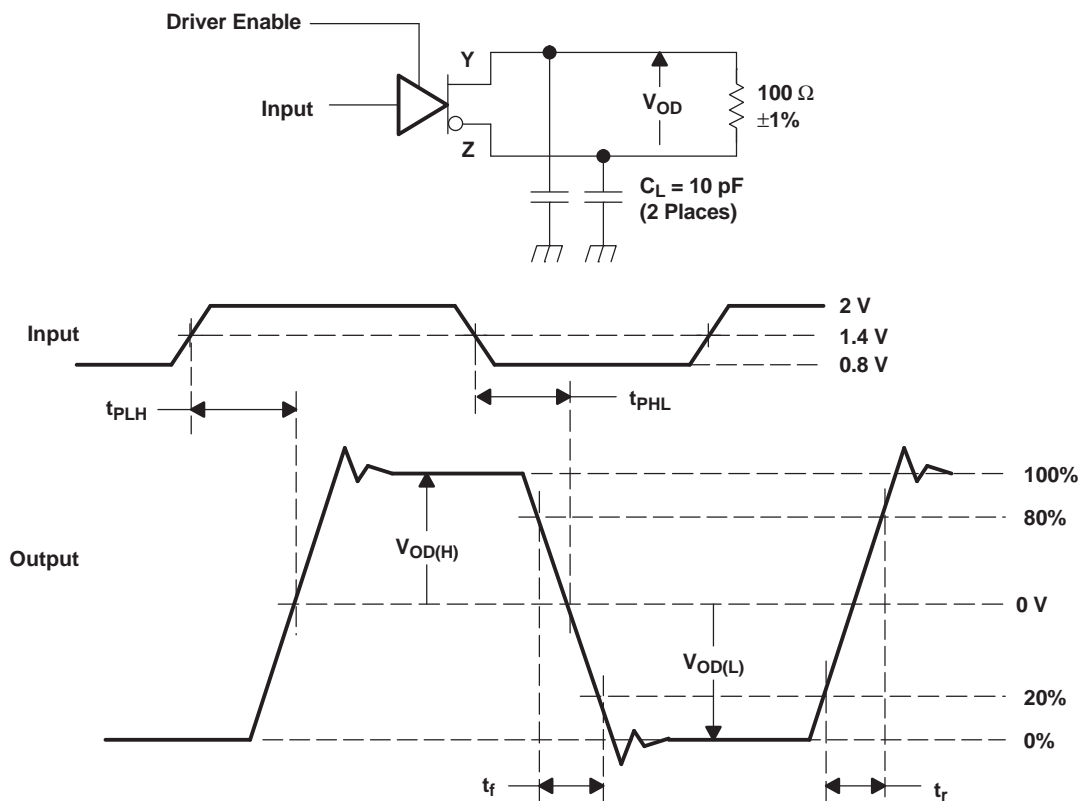

Figure 1. Driver Voltage and Current Definitions



- A. All input pulses are supplied by a generator having the following characteristics:  $t_r$  or  $t_f \leq 1$  ns, pulse repetition rate (PRR) = 50 Mpps, pulse width =  $10 \pm 0.2$  ns.  $C_L$  includes instrumentation and fixture capacitance within 0,06 mm of the D.U.T.

Figure 2. Test Circuit, Timing, and Voltage Definitions for the Differential Output Signal

PARAMETER MEASUREMENT INFORMATION (continued)

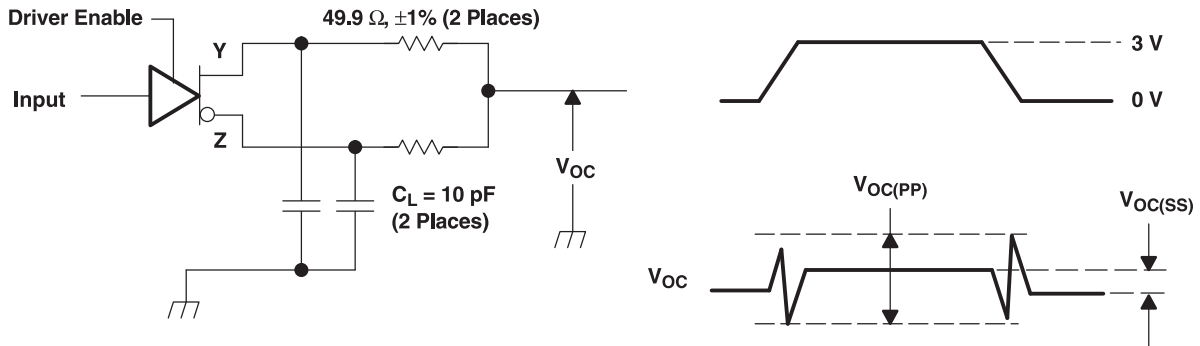

- A. All input pulses are supplied by a generator having the following characteristics:  $t_r$  or  $t_f \leq 1$  ns, pulse repetition rate (PRR) = 50 Mpps, pulse width =  $10 \pm 0.2$  ns.  $C_L$  includes instrumentation and fixture capacitance within 0,06 mm of the D.U.T. The measurement of  $V_{OC(PP)}$  is made on test equipment with a  $-3$ -dB bandwidth of at least 300 MHz.

Figure 3. Test Circuit and Definitions for the Driver Common-Mode Output Voltage

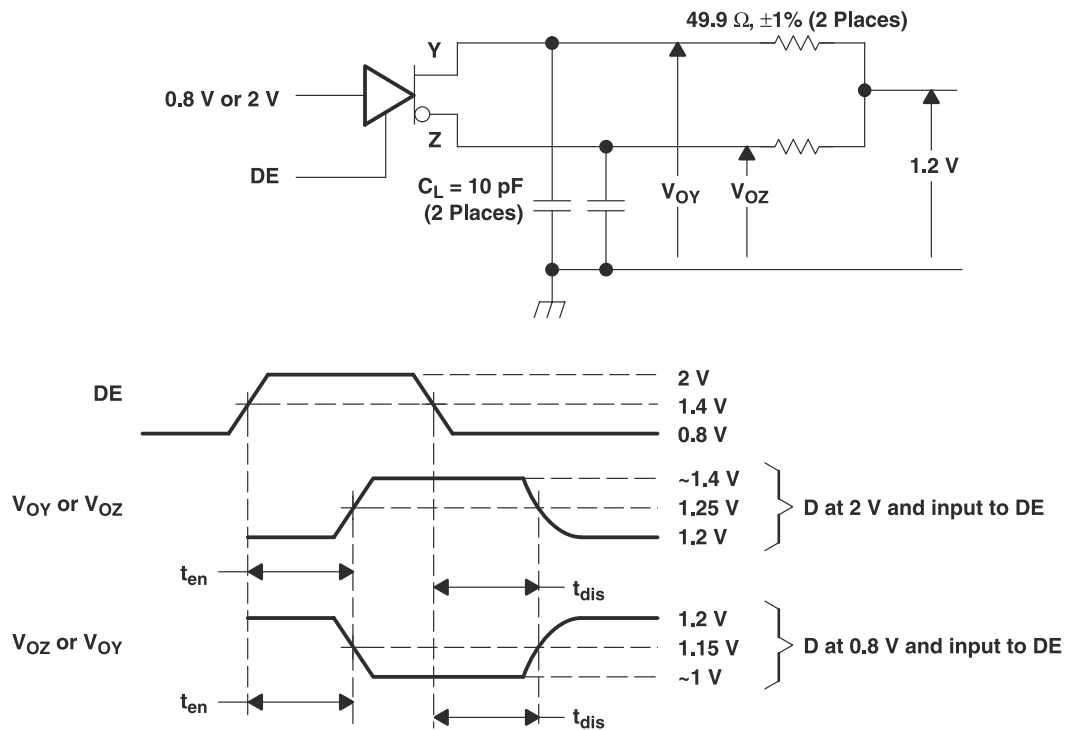

- A. All input pulses are supplied by a generator having the following characteristics:  $t_r$  or  $t_f \leq 1$  ns, pulse repetition rate (PRR) = 0.5 Mpps, pulse width =  $500 \pm 10$  ns.  $C_L$  includes instrumentation and fixture capacitance within 0,06 mm of the D.U.T.

Figure 4. Enable and Disable Time Circuit and Definitions

PARAMETER MEASUREMENT INFORMATION (continued)

RECEIVER

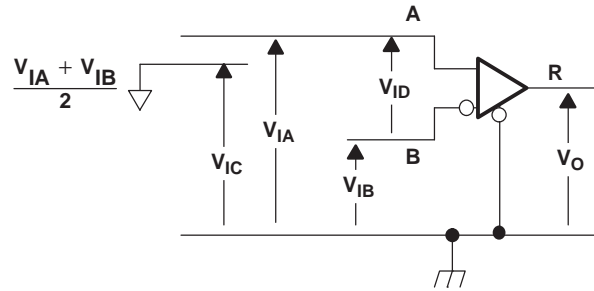
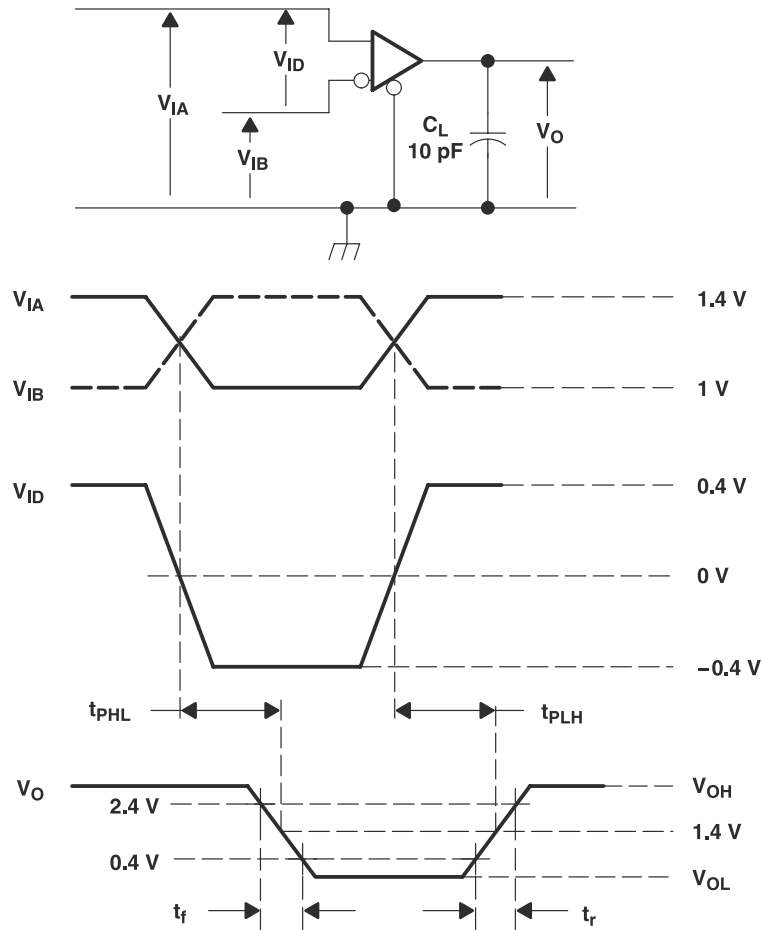

Figure 5. Receiver Voltage Definitions

Receiver Minimum and Maximum Input Threshold Test Voltages

APPLIED VOLTAGES (V)		RESULTING DIFFERENTIAL INPUT VOLTAGE (mV)	RESULTING COMMON-MODE INPUT VOLTAGE (V)
$V_{IA}$	$V_{IB}$	$V_{ID}$	$V_{IC}$
1.25	1.15	100	1.2
1.15	1.25	-100	1.2
2.4	2.3	100	2.35
2.3	2.4	-100	2.35
0.1	0	100	0.05
0	0.1	-100	0.05
1.5	0.9	600	1.2
0.9	1.5	-600	1.2
2.4	1.8	600	2.1
1.8	2.4	-600	2.1
0.6	0	600	0.3
0	0.6	-600	0.3



- A. All input pulses are supplied by a generator having the following characteristics:  $t_r$  or  $t_f \leq 1$  ns, pulse repetition rate (PRR) = 50 Mpps, pulse width =  $10 \pm 0.2$  ns.  $C_L$  includes instrumentation and fixture capacitance within 0,06 m of the D.U.T.

**Figure 6. Timing Test Circuit and Waveforms**

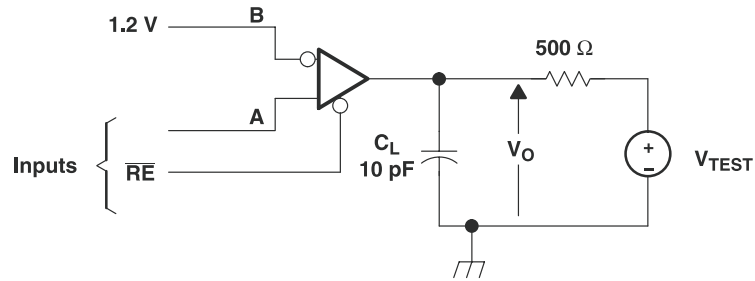

NOTE A: All input pulses are supplied by a generator having the following characteristics:  $t_r$  or  $t_f \leq 1$  ns, pulse repetition rate (PRR) = 0.5 Mpps, pulse width =  $500 \pm 10$  ns.  $C_L$  includes instrumentation and fixture capacitance within 0,06 m of the D.U.T.

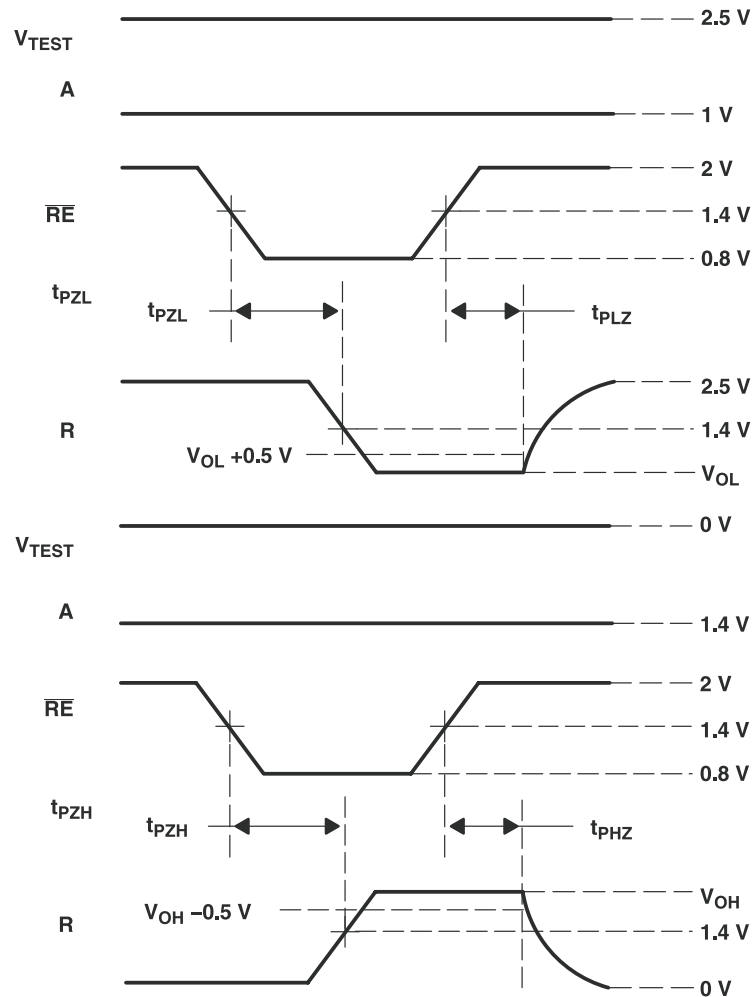
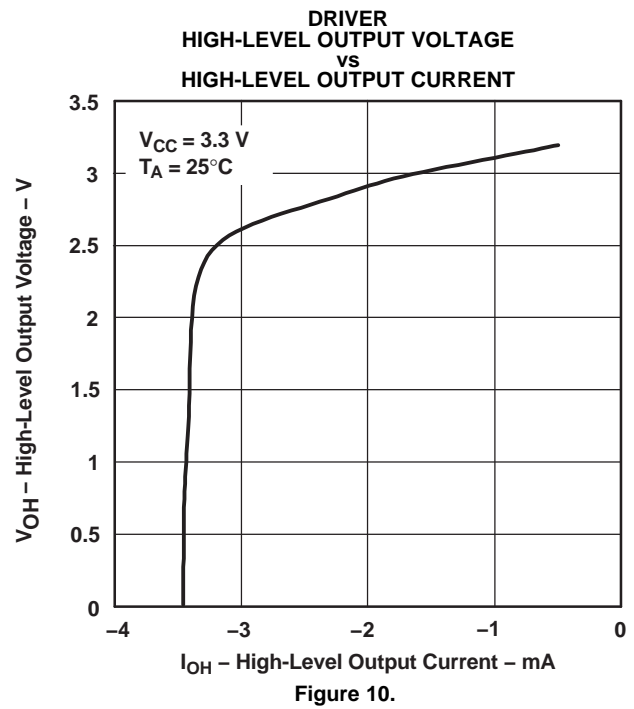
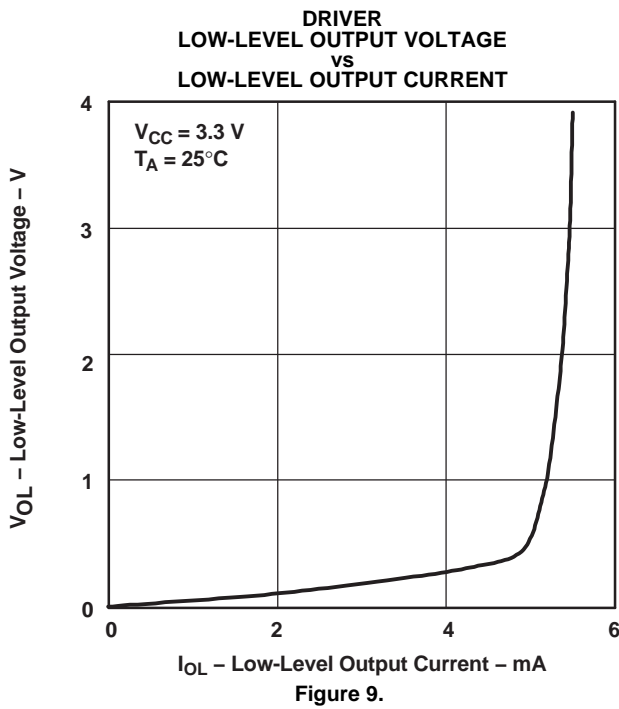
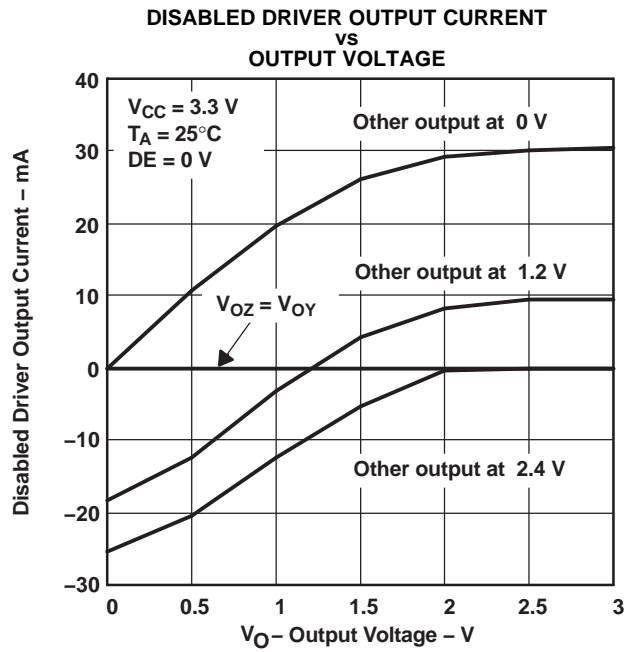

Figure 7. Enable/Disable Time Test Circuit and Waveforms

## TYPICAL CHARACTERISTICS



TYPICAL CHARACTERISTICS (continued)

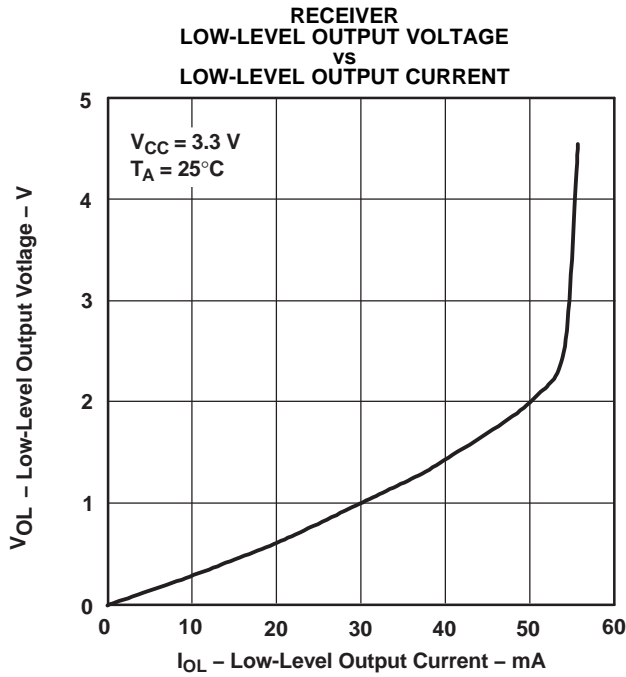

Figure 11.

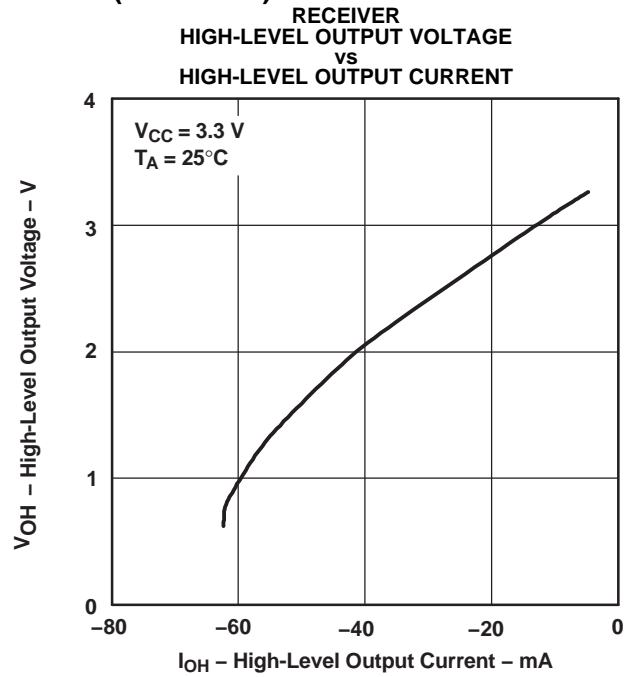

Figure 12.

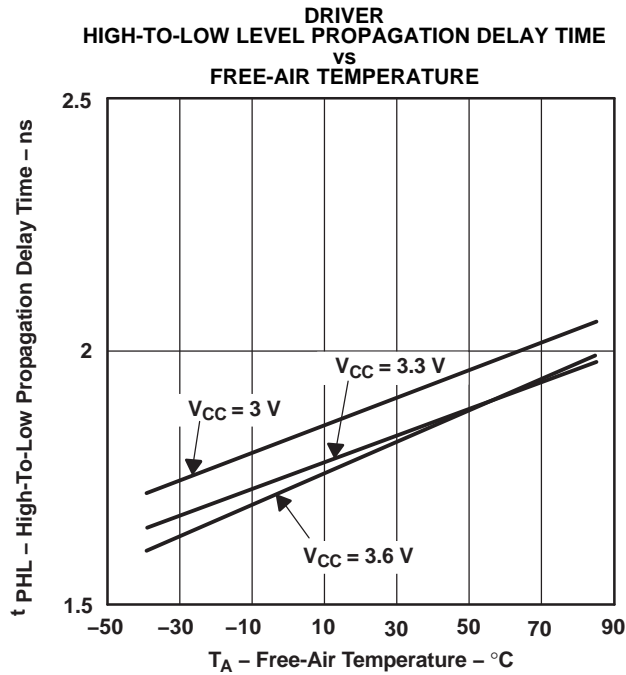

Figure 13.

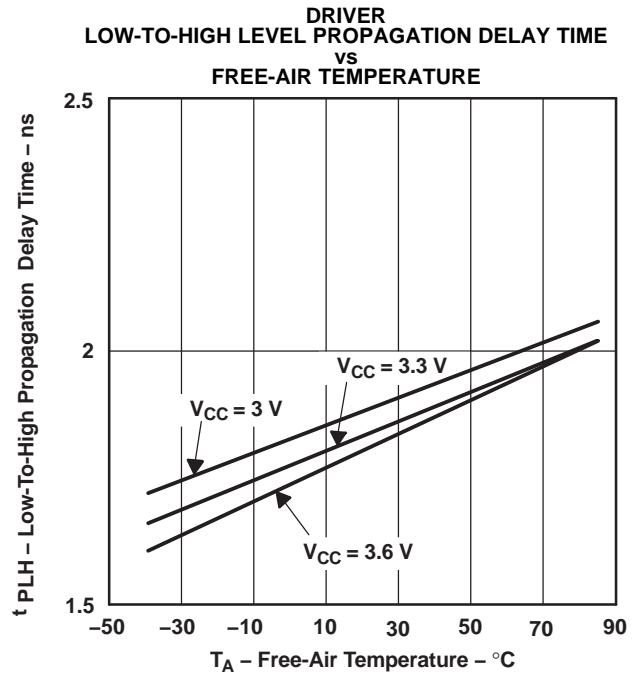

Figure 14.

**TYPICAL CHARACTERISTICS (continued)**  
 RECEIVER  
 HIGH-TO-LOW LEVEL PROPAGATION DELAY TIME  
 VS  
 FREE-AIR TEMPERATURE

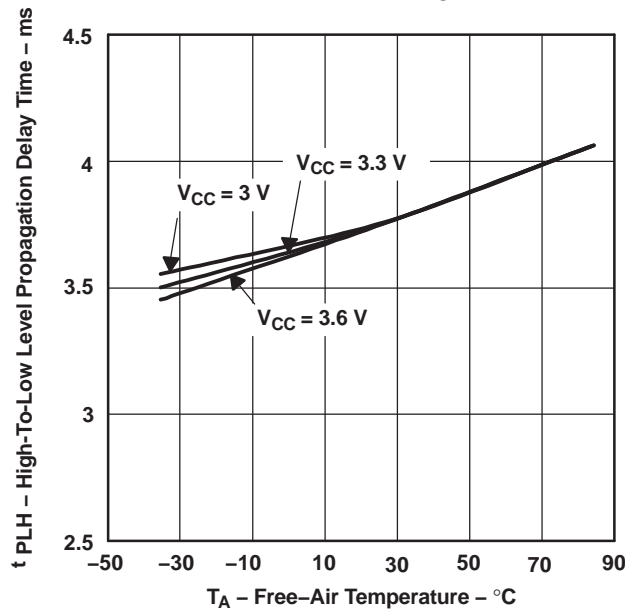

Figure 15.

**TYPICAL CHARACTERISTICS (continued)**  
 RECEIVER  
 LOW-TO-HIGH LEVEL PROPAGATION DELAY TIME  
 VS  
 FREE-AIR TEMPERATURE

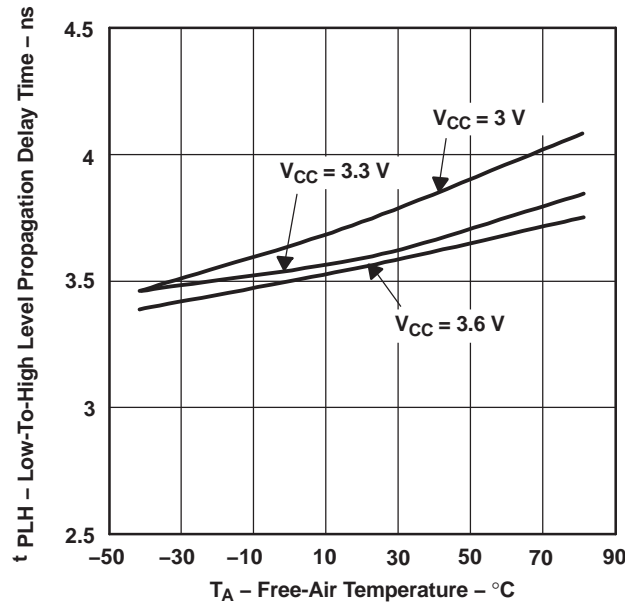

Figure 16.

## APPLICATION INFORMATION

The devices are generally used as building blocks for high-speed point-to-point data transmission. Ground differences are less than 1 V with a low common-mode output and balanced interface for low noise emissions. Devices can interoperate with RS-422, PECL, and IEEE-P1596. Drivers/receivers maintain ECL speeds without the power and dual supply requirements.

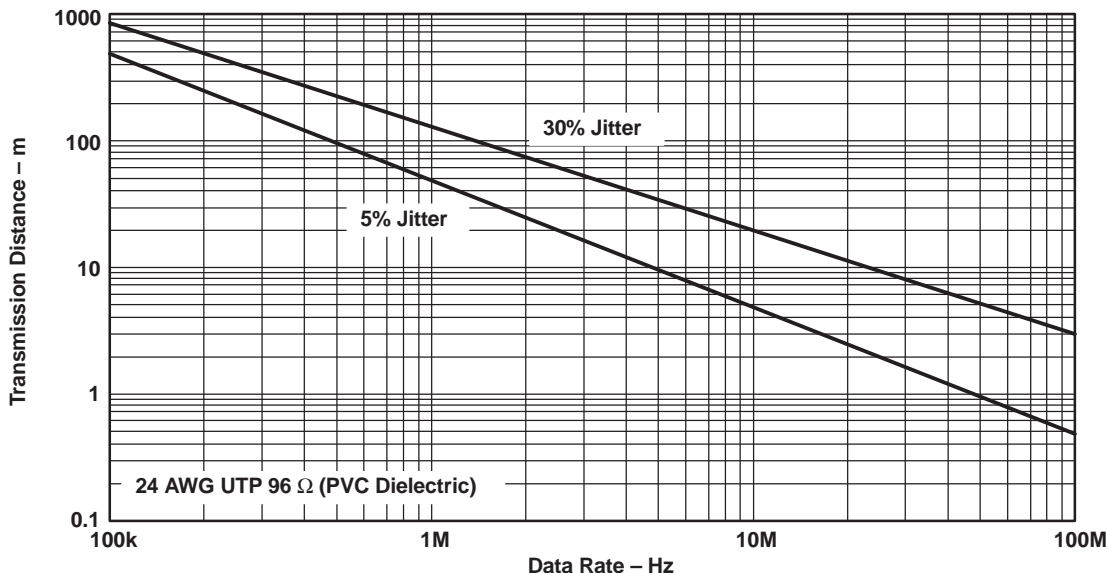

Figure 17. Data Transmission Distance Versus Rate

## FAIL SAFE

One of the most common problems with differential signaling applications is how the system responds when no differential voltage is present on the signal pair. The LVDS receiver is like most differential line receivers, in that its output logic state can be indeterminate when the differential input voltage is between -100 mV and 100 mV and within its recommended input common-mode voltage range. TI's LVDS receiver is different in how it handles the open-input circuit situation, however.

Open-circuit means that there is little or no input current to the receiver from the data line itself. This could be when the driver is in a high-impedance state or the cable is disconnected. When this occurs, the LVDS receiver pulls each line of the signal pair to near  $V_{CC}$  through 300-k $\Omega$  resistors as shown in Figure 11. The fail-safe feature uses an AND gate with input voltage thresholds at about 2.3 V to  $V_{CC} - 0.4$  V to detect this condition and force the output to a high-level regardless of the differential input voltage.

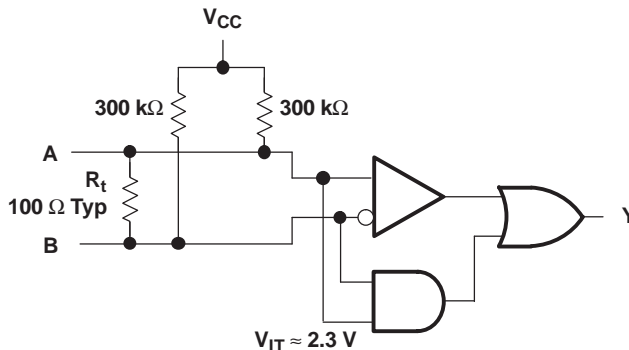

Figure 18. Open-Circuit Fail Safe of the LVDS Receiver

It is only under these conditions that the output of the receiver will be valid with less than a 100-mV differential input voltage magnitude. The presence of the termination resistor,  $R_t$ , does not affect the fail-safe function as long as it is connected as shown in the figure. Other termination circuits may allow a dc current to ground that could defeat the pullup currents from the receiver and the fail-safe feature.

## REVISION HISTORY

---

### Changes from Original (September 2003) to Revision A Page

- Deleted Feature: "Qualification in Accordance With AEC-Q100†" ..... 1
  - Deleted Feature: "Customer-Specific Configuration Control..." ..... 1
- 

### Changes from Revision A (April 2008) to Revision B Page

- Changed device number From: SN65LVDS050PWRQ1 To: SN65LVDS050IPWRQ1. Changed the device status to Production ..... 2
- 

### Changes from Revision B (November 2011) to Revision C Page

- Deleted device SN65LVDS179-Q1 ..... 1
-

**PACKAGING INFORMATION**

Orderable Device	Status (1)	Package Type	Package Drawing	Pins	Package Qty	Eco Plan (2)	Lead/Ball Finish (6)	MSL Peak Temp (3)	Op Temp (°C)	Device Marking (4/5)	Samples
SN65LVDS050IPWRQ1	ACTIVE	TSSOP	PW	16	2000	Green (RoHS & no Sb/Br)	CU NIPDAU	Level-1-260C-UNLIM	-40 to 85	VDS050Q	<a href="#">Samples</a>
SN65LVDS051DRG4Q1	ACTIVE	SOIC	D	16	2500	Green (RoHS & no Sb/Br)	CU NIPDAU	Level-1-260C-UNLIM	-40 to 85	VDS051Q	<a href="#">Samples</a>
SN65LVDS051PWRG4Q1	ACTIVE	TSSOP	PW	16	2000	Green (RoHS & no Sb/Br)	CU NIPDAU	Level-1-260C-UNLIM	-40 to 85	VDS051Q	<a href="#">Samples</a>
SN65LVDS051PWRQ1	ACTIVE	TSSOP	PW	16	2000	Green (RoHS & no Sb/Br)	CU NIPDAU	Level-1-260C-UNLIM	-40 to 85	VDS051Q	<a href="#">Samples</a>
SN65LVDS180PWRG4Q1	ACTIVE	TSSOP	PW	14	2000	Green (RoHS & no Sb/Br)	CU NIPDAU	Level-1-260C-UNLIM	-40 to 85	VDS180Q	<a href="#">Samples</a>
SN65LVDS180PWRQ1	ACTIVE	TSSOP	PW	14	2000	Green (RoHS & no Sb/Br)	CU NIPDAU	Level-1-260C-UNLIM	-40 to 85	VDS180Q	<a href="#">Samples</a>

(1) The marketing status values are defined as follows:

**ACTIVE:** Product device recommended for new designs.

**LIFEBUY:** TI has announced that the device will be discontinued, and a lifetime-buy period is in effect.

**NRND:** Not recommended for new designs. Device is in production to support existing customers, but TI does not recommend using this part in a new design.

**PREVIEW:** Device has been announced but is not in production. Samples may or may not be available.

**OBSELETE:** TI has discontinued the production of the device.

(2) Eco Plan - The planned eco-friendly classification: Pb-Free (RoHS), Pb-Free (RoHS Exempt), or Green (RoHS & no Sb/Br) - please check <http://www.ti.com/productcontent> for the latest availability information and additional product content details.

**TBD:** The Pb-Free/Green conversion plan has not been defined.

**Pb-Free (RoHS):** TI's terms "Lead-Free" or "Pb-Free" mean semiconductor products that are compatible with the current RoHS requirements for all 6 substances, including the requirement that lead not exceed 0.1% by weight in homogeneous materials. Where designed to be soldered at high temperatures, TI Pb-Free products are suitable for use in specified lead-free processes.

**Pb-Free (RoHS Exempt):** This component has a RoHS exemption for either 1) lead-based flip-chip solder bumps used between the die and package, or 2) lead-based die adhesive used between the die and leadframe. The component is otherwise considered Pb-Free (RoHS compatible) as defined above.

**Green (RoHS & no Sb/Br):** TI defines "Green" to mean Pb-Free (RoHS compatible), and free of Bromine (Br) and Antimony (Sb) based flame retardants (Br or Sb do not exceed 0.1% by weight in homogeneous material)

(3) MSL, Peak Temp. - The Moisture Sensitivity Level rating according to the JEDEC industry standard classifications, and peak solder temperature.

(4) There may be additional marking, which relates to the logo, the lot trace code information, or the environmental category on the device.

(5) Multiple Device Markings will be inside parentheses. Only one Device Marking contained in parentheses and separated by a "~" will appear on a device. If a line is indented then it is a continuation of the previous line and the two combined represent the entire Device Marking for that device.

<sup>(6)</sup> Lead/Ball Finish - Orderable Devices may have multiple material finish options. Finish options are separated by a vertical ruled line. Lead/Ball Finish values may wrap to two lines if the finish value exceeds the maximum column width.

**Important Information and Disclaimer:**The information provided on this page represents TI's knowledge and belief as of the date that it is provided. TI bases its knowledge and belief on information provided by third parties, and makes no representation or warranty as to the accuracy of such information. Efforts are underway to better integrate information from third parties. TI has taken and continues to take reasonable steps to provide representative and accurate information but may not have conducted destructive testing or chemical analysis on incoming materials and chemicals. TI and TI suppliers consider certain information to be proprietary, and thus CAS numbers and other limited information may not be available for release.

In no event shall TI's liability arising out of such information exceed the total purchase price of the TI part(s) at issue in this document sold by TI to Customer on an annual basis.

**OTHER QUALIFIED VERSIONS OF SN65LVDS050-Q1, SN65LVDS051-Q1, SN65LVDS180-Q1 :**

- Catalog: [SN65LVDS050](#), [SN65LVDS051](#), [SN65LVDS180](#)

NOTE: Qualified Version Definitions:

- Catalog - TI's standard catalog product

## TAPE AND REEL INFORMATION



### QUADRANT ASSIGNMENTS FOR PIN 1 ORIENTATION IN TAPE



\*All dimensions are nominal

Device	Package Type	Package Drawing	Pins	SPQ	Reel Diameter (mm)	Reel Width W1 (mm)	A0 (mm)	B0 (mm)	K0 (mm)	P1 (mm)	W (mm)	Pin1 Quadrant
SN65LVDS051PWRG4Q1	TSSOP	PW	16	2000	330.0	12.4	6.9	5.6	1.6	8.0	12.0	Q1
SN65LVDS051PWRQ1	TSSOP	PW	16	2000	330.0	12.4	6.9	5.6	1.6	8.0	12.0	Q1
SN65LVDS180PWRG4Q1	TSSOP	PW	14	2000	330.0	12.4	6.9	5.6	1.6	8.0	12.0	Q1
SN65LVDS180PWRQ1	TSSOP	PW	14	2000	330.0	12.4	6.9	5.6	1.6	8.0	12.0	Q1

**TAPE AND REEL BOX DIMENSIONS**

\*All dimensions are nominal

Device	Package Type	Package Drawing	Pins	SPQ	Length (mm)	Width (mm)	Height (mm)
SN65LVDS051PWRG4Q1	TSSOP	PW	16	2000	367.0	367.0	35.0
SN65LVDS051PWRQ1	TSSOP	PW	16	2000	367.0	367.0	35.0
SN65LVDS180PWRG4Q1	TSSOP	PW	14	2000	367.0	367.0	35.0
SN65LVDS180PWRQ1	TSSOP	PW	14	2000	367.0	367.0	35.0

PW (R-PDSO-G14)

PLASTIC SMALL OUTLINE

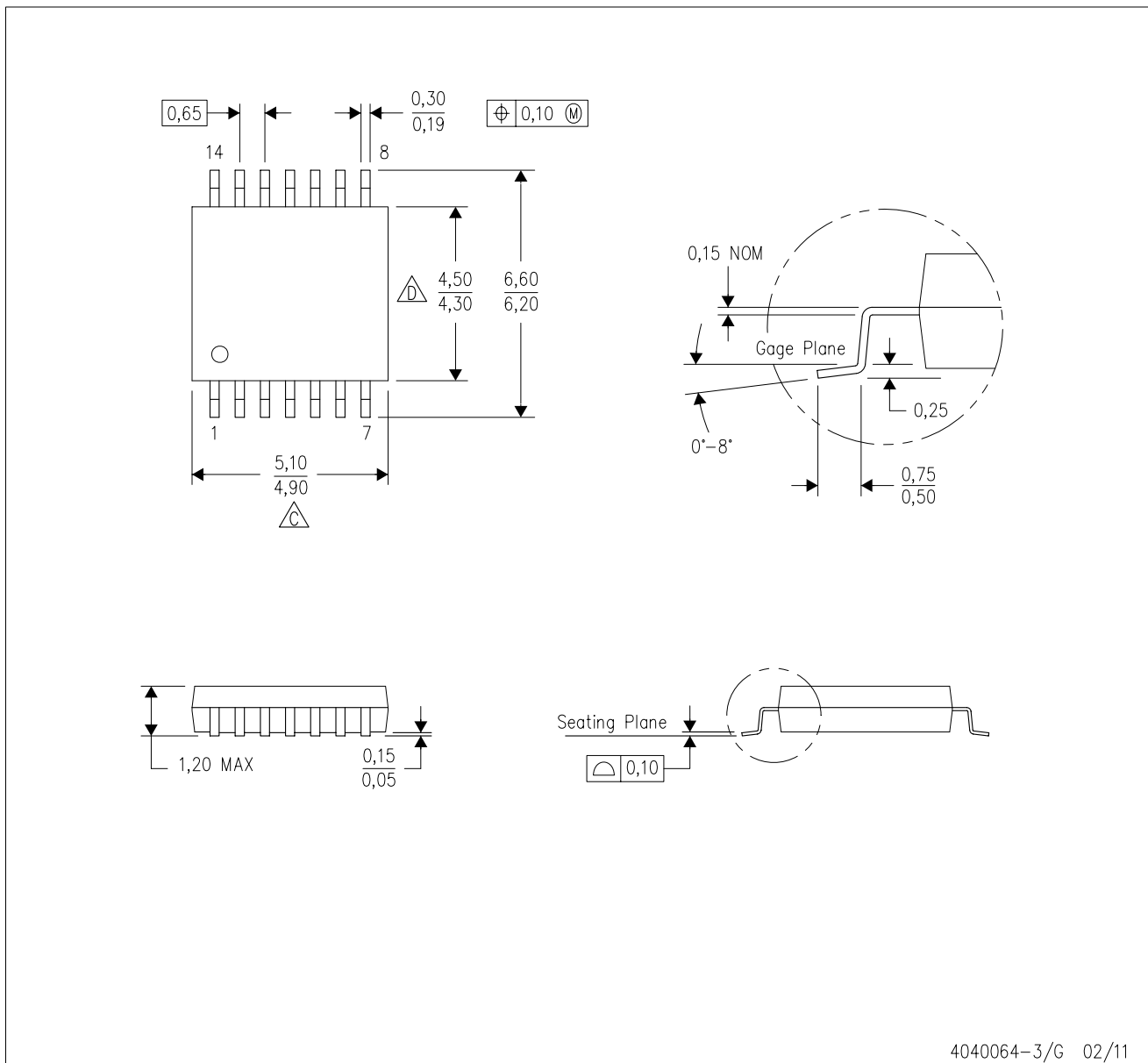

- NOTES:
- A. All linear dimensions are in millimeters. Dimensioning and tolerancing per ASME Y14.5M-1994.
  - B. This drawing is subject to change without notice.
  - C. Body length does not include mold flash, protrusions, or gate burrs. Mold flash, protrusions, or gate burrs shall not exceed 0,15 each side.
  - D. Body width does not include interlead flash. Interlead flash shall not exceed 0,25 each side.
  - E. Falls within JEDEC MO-153

PW (R-PDSO-G14)

PLASTIC SMALL OUTLINE



4211284-2/G 08/15

- NOTES:
- All linear dimensions are in millimeters.
  - This drawing is subject to change without notice.
  - Publication IPC-7351 is recommended for alternate designs.
  - Laser cutting apertures with trapezoidal walls and also rounding corners will offer better paste release. Customers should contact their board assembly site for stencil design recommendations. Refer to IPC-7525 for other stencil recommendations.
  - Customers should contact their board fabrication site for solder mask tolerances between and around signal pads.

D (R-PDSO-G16)

PLASTIC SMALL OUTLINE



- NOTES:
- A. All linear dimensions are in inches (millimeters).
  - B. This drawing is subject to change without notice.
  - C. Body length does not include mold flash, protrusions, or gate burrs. Mold flash, protrusions, or gate burrs shall not exceed 0.006 (0,15) each side.
  - D. Body width does not include interlead flash. Interlead flash shall not exceed 0.017 (0,43) each side.
  - E. Reference JEDEC MS-012 variation AC.

D (R-PDSO-G16)

PLASTIC SMALL OUTLINE



- NOTES:
- All linear dimensions are in millimeters.
  - This drawing is subject to change without notice.
  - Publication IPC-7351 is recommended for alternate designs.
  - Laser cutting apertures with trapezoidal walls and also rounding corners will offer better paste release. Customers should contact their board assembly site for stencil design recommendations. Refer to IPC-7525 for other stencil recommendations.
  - Customers should contact their board fabrication site for solder mask tolerances between and around signal pads.

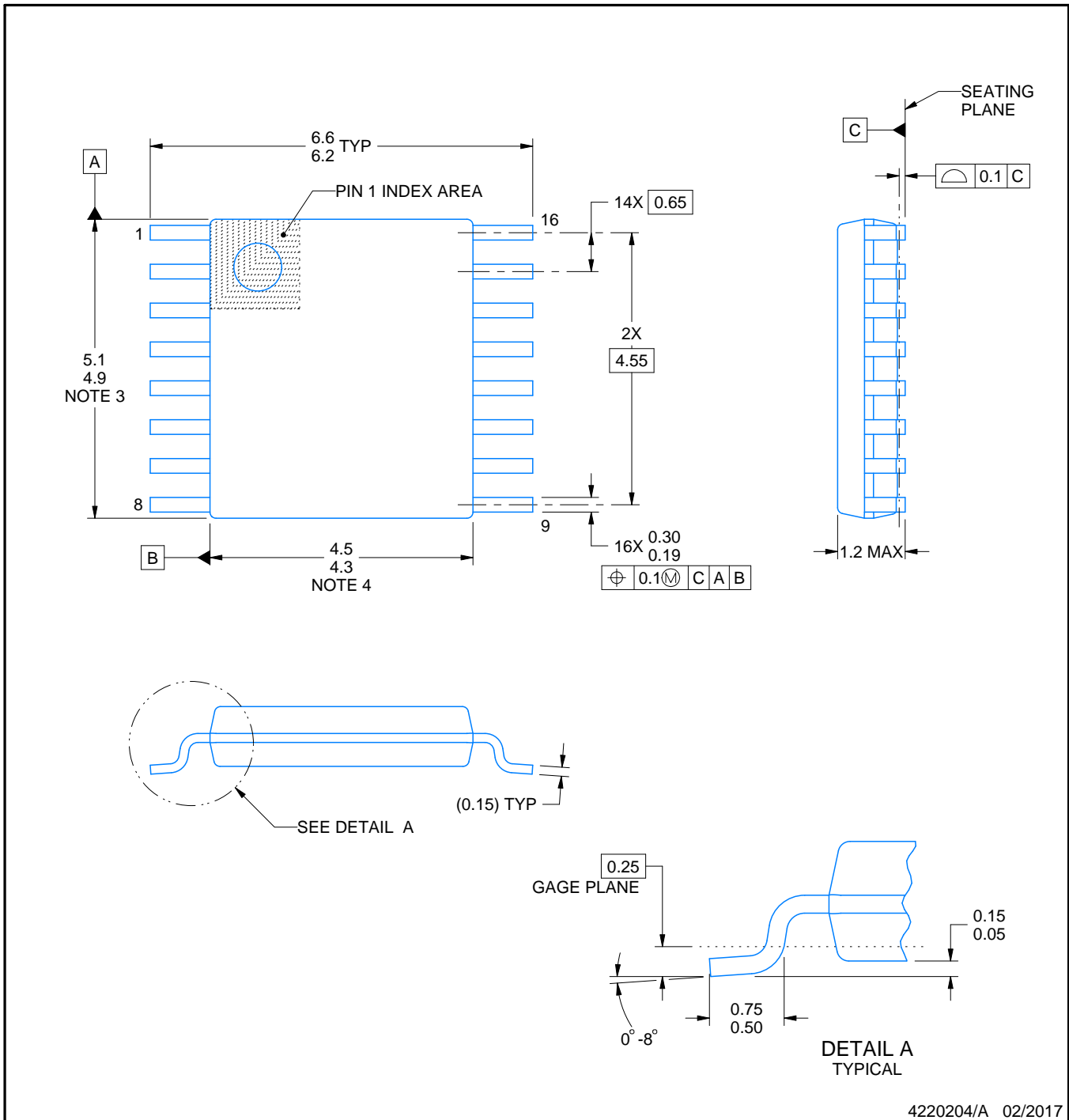

4220204/A 02/2017

NOTES:

1. All linear dimensions are in millimeters. Any dimensions in parenthesis are for reference only. Dimensioning and tolerancing per ASME Y14.5M.
2. This drawing is subject to change without notice.
3. This dimension does not include mold flash, protrusions, or gate burrs. Mold flash, protrusions, or gate burrs shall not exceed 0.15 mm per side.
4. This dimension does not include interlead flash. Interlead flash shall not exceed 0.25 mm per side.
5. Reference JEDEC registration MO-153.

# EXAMPLE BOARD LAYOUT

PW0016A

TSSOP - 1.2 mm max height

SMALL OUTLINE PACKAGE



LAND PATTERN EXAMPLE  
EXPOSED METAL SHOWN  
SCALE: 10X



4220204/A 02/2017

NOTES: (continued)

6. Publication IPC-7351 may have alternate designs.
7. Solder mask tolerances between and around signal pads can vary based on board fabrication site.

# EXAMPLE STENCIL DESIGN

PW0016A

TSSOP - 1.2 mm max height

SMALL OUTLINE PACKAGE

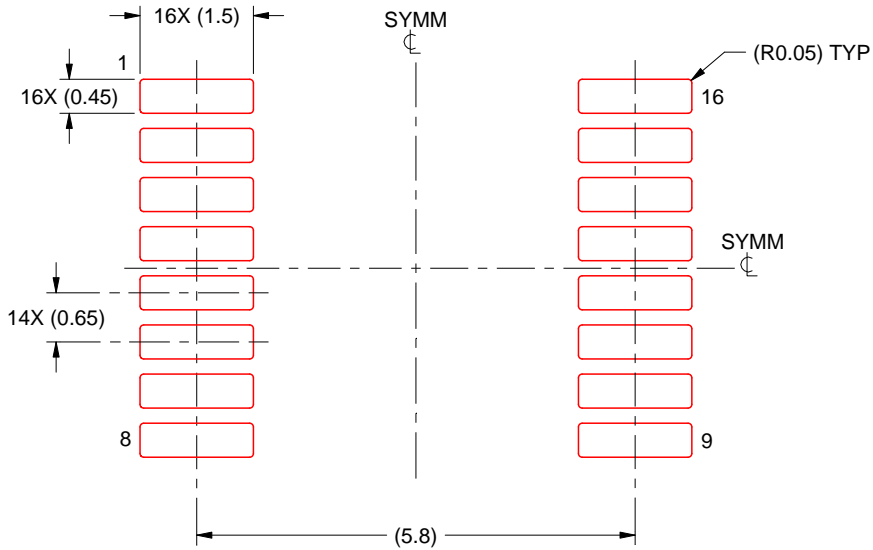

SOLDER PASTE EXAMPLE  
BASED ON 0.125 mm THICK STENCIL  
SCALE: 10X

4220204/A 02/2017

NOTES: (continued)

8. Laser cutting apertures with trapezoidal walls and rounded corners may offer better paste release. IPC-7525 may have alternate design recommendations.
9. Board assembly site may have different recommendations for stencil design.

## IMPORTANT NOTICE AND DISCLAIMER

TI PROVIDES TECHNICAL AND RELIABILITY DATA (INCLUDING DATASHEETS), DESIGN RESOURCES (INCLUDING REFERENCE DESIGNS), APPLICATION OR OTHER DESIGN ADVICE, WEB TOOLS, SAFETY INFORMATION, AND OTHER RESOURCES "AS IS" AND WITH ALL FAULTS, AND DISCLAIMS ALL WARRANTIES, EXPRESS AND IMPLIED, INCLUDING WITHOUT LIMITATION ANY IMPLIED WARRANTIES OF MERCHANTABILITY, FITNESS FOR A PARTICULAR PURPOSE OR NON-INFRINGEMENT OF THIRD PARTY INTELLECTUAL PROPERTY RIGHTS.

These resources are intended for skilled developers designing with TI products. You are solely responsible for (1) selecting the appropriate TI products for your application, (2) designing, validating and testing your application, and (3) ensuring your application meets applicable standards, and any other safety, security, or other requirements. These resources are subject to change without notice. TI grants you permission to use these resources only for development of an application that uses the TI products described in the resource. Other reproduction and display of these resources is prohibited. No license is granted to any other TI intellectual property right or to any third party intellectual property right. TI disclaims responsibility for, and you will fully indemnify TI and its representatives against, any claims, damages, costs, losses, and liabilities arising out of your use of these resources.

TI's products are provided subject to TI's Terms of Sale ([www.ti.com/legal/termsofsale.html](http://www.ti.com/legal/termsofsale.html)) or other applicable terms available either on [ti.com](http://ti.com) or provided in conjunction with such TI products. TI's provision of these resources does not expand or otherwise alter TI's applicable warranties or warranty disclaimers for TI products.

Mailing Address: Texas Instruments, Post Office Box 655303, Dallas, Texas 75265  
Copyright © 2019, Texas Instruments Incorporated

## Looking for pricing, stock, or lifecycle information?

Click below to explore more details on WIN SOURCE:

 [View SN65LVDS180PWRQ1 on WIN SOURCE](#)

 [Texas Instruments](#) Information

## Optimize Your Supply Chain with WIN SOURCE Solutions

-  Global Sourcing Solution
-  Obsolete Management
-  Cost Control Management
-  Shortage Management
-  Alternative Solution
-  Excess Inventory Management