



THE DATASHEET OF LMV712IDGSR



FEATURES

- 5-MHz Gain Bandwidth Product
- 5-V/ μ s Slew Rate
- Low Noise: 20 nV/ $\sqrt{\text{Hz}}$
- 1.22-mA/Channel Supply Current
- $V_{OS} < 3$ mV Max
- Low Supply Voltage: 2.7 V to 5 V
- Rail-to-Rail Inputs and Outputs
- Unity Gain Stable
- 1.5- μ A Shutdown I_{CC}
- 2.2- μ s Turn On

APPLICATIONS

- Power-Amplifier Control Loops
- Cellular Phones
- Portable Equipment
- Wireless LANs
- Radio Systems
- Cordless Phones

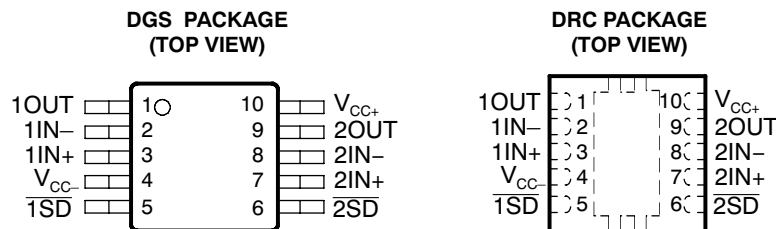

DESCRIPTION/ORDERING INFORMATION

The LMV712 dual operational amplifier is a high-performance BiCMOS operational amplifier intended for applications requiring rail-to-rail inputs, combined with speed and low noise. The device offers a bandwidth of 5 MHz, a slew rate of 5 V/ μ s, and operates with capacitive loads of up to 200 pF without oscillation.

The LMV712 offers two independent shutdown ($\overline{1SD}$, $\overline{2SD}$) pins. This feature allows disabling of each device separately and reduces the supply current to less than 1 μ A typical. The output voltage rapidly and smoothly ramps up with no glitch as the amplifier comes out of the shutdown mode.

The LMV712 is offered in the space-saving SON (DRC) package and in an MSOP (DGS) package. These packages are designed to meet the demands of small size, low power, and low cost required by cellular phones and similar battery-operated portable electronics.

ORDERING INFORMATION

T_A	PACKAGE ⁽¹⁾		ORDERABLE PART NUMBER	TOP-SIDE MARKING
-40°C to 85°C	MSOP – DGS	Reel of 2500	LMV712IDGSR	RNB
		Reel of 250	LMV712IDGST	
	SON – DRC	Reel of 3000	LMV712IDRCR	PREVIEW
		Reel of 250	LMV712IDRCT	

(1) Package drawings, standard packing quantities, thermal data, symbolization, and PCB design guidelines are available at www.ti.com/sc/package.



Please be aware that an important notice concerning availability, standard warranty, and use in critical applications of Texas Instruments semiconductor products and disclaimers thereto appears at the end of this data sheet.

SYMBOL (EACH AMPLIFIER)

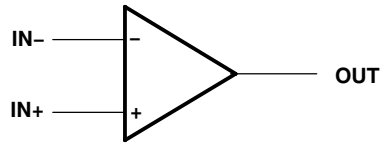

SIMPLIFIED SCHEMATIC (EACH AMPLIFIER)

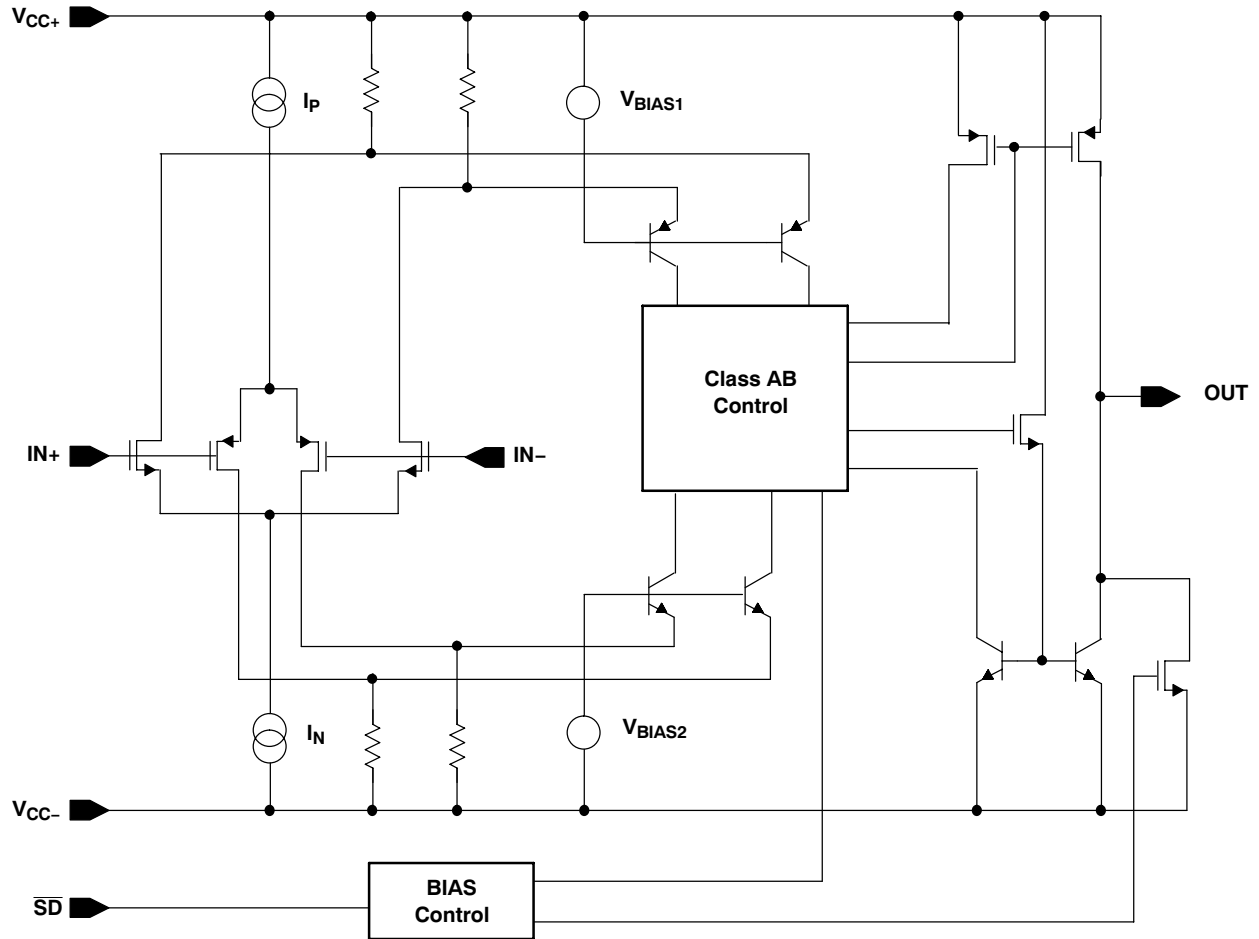

Absolute Maximum Ratings⁽¹⁾

over operating free-air temperature range (unless otherwise noted)

		MIN	MAX	UNIT
$V_{CC+} - V_{CC-}$	Supply voltage ⁽²⁾		5.5	V
V_{ID}	Differential input voltage ⁽³⁾		±Supply voltage	V
V_I	Input voltage range (any input)	$V_{CC-} - 0.4$	$V_{CC+} + 0.4$	V
V_O	Output voltage range	$V_{CC-} - 0.4$	$V_{CC+} + 0.4$	V
I_I	Input current ⁽⁴⁾		±10	mA
I_O	Output current		±50	mA
θ_{JA}	Package thermal impedance ^{(5) (6)}	DGS package	165	°C/W
		DRC package	TBD	
T_J	Operating virtual junction temperature		150	°C
T_{stg}	Storage temperature range	-65	150	°C

- (1) Stresses beyond those listed under “absolute maximum ratings” may cause permanent damage to the device. These are stress ratings only, and functional operation of the device at these or any other conditions beyond those indicated under “recommended operating conditions” is not implied. Exposure to absolute-maximum-rated conditions for extended periods may affect device reliability.
- (2) All voltage values (except differential voltages and V_{CC} specified for the measurement of I_{OS}) are with respect to the network GND.
- (3) Differential voltages are at $IN+$ with respect to $IN-$.
- (4) Excessive input current will flow if a differential input voltage in excess of approximately 0.6 V is applied between the inputs, unless some limiting resistance is used.
- (5) Maximum power dissipation is a function of $T_J(\max)$, θ_{JA} , and T_A . The maximum allowable power dissipation at any allowable ambient temperature is $P_D = (T_J(\max) - T_A)/\theta_{JA}$. Operating at the absolute maximum T_J of 150°C can affect reliability.
- (6) The package thermal impedance is calculated in accordance with JESD 51-7.

ESD Protection

	TYP	UNIT
Human-Body Model	1500	V
Machine Model	150	V

Recommended Operating Conditions

		MIN	MAX	UNIT
$V_{CC+} - V_{CC-}$	Supply voltage	2.7	5	V
T_A	Operating free-air temperature	-40	85	°C

Electrical Characteristics

$V_{CC+} = 2.7\text{ V}$, $V_{CC-} = \text{GND}$, $V_{CM} = 1.35\text{ V}$, and $R_L > 1\text{ M}\Omega$ (unless otherwise noted)

PARAMETER		TEST CONDITIONS		T_A	MIN	TYP	MAX	UNIT
V_{IO}	Input offset voltage	$V_{CM} = 0.85\text{ V}$ and 1.85 V		25°C		0.4	3	mV
				–40°C to 85°C			3.2	
I_{IB}	Input bias current			25°C		5.5	115	pA
				–40°C to 85°C			130	
CMRR	Common-mode rejection ratio	$0 \leq V_{CM} \leq 2.7\text{ V}$		25°C	50	75		dB
				–40°C to 85°C	45			
PSRR	Power-supply rejection ratio	$2.7\text{ V} \leq V_{CC+} \leq 5\text{ V}$	$V_{CM} = 0.85\text{ V}$	25°C	70	90		dB
				–40°C to 85°C	68			
			$V_{CM} = 1.85\text{ V}$	25°C	70	90		
				–40°C to 85°C	68			
CMVR	Common-mode voltage range	CMRR $\geq 50\text{ dB}$		25°C		–0.3	–0.2	V
					2.9	3		
I_{SC}	Output short-circuit current ⁽¹⁾	Sourcing $V_O = 0$		25°C	15	25		mA
				–40°C to 85°C	12			
		Sinking $V_O = 2.7\text{ V}$		25°C	25	50		
				–40°C to 85°C	22			
V_O	Output voltage swing	$R_L = 10\text{ k}\Omega$ to 1.35 V	V_{OH}	25°C	2.62	2.68		V
				–40°C to 85°C	2.6			
			V_{OL}	25°C		0.01	0.12	
				–40°C to 85°C			0.15	
		$R_L = 600\ \Omega$ to 1.35 V	V_{OH}	25°C	2.52	2.55		
				–40°C to 85°C	2.5			
			V_{OL}	25°C		0.05	0.23	
				–40°C to 85°C			0.3	
$V_{O(SD)}$	Output voltage level in shutdown mode			25°C		10	200	mV
I_{CC}	Supply current per channel	ON mode		25°C		1.22	1.7	mA
				–40°C to 85°C			1.9	
		Shutdown mode		25°C		0.12	1.5	μA
				–40°C to 85°C			2	
A_{VOL}	Large-signal voltage gain	Sourcing $R_L = 10\text{ k}\Omega$, $V_O = 1.35\text{ V}$ to 2.3 V		25°C	80	115		dB
				–40°C to 85°C	76			
		Sinking $R_L = 10\text{ k}\Omega$, $V_O = 0.4\text{ V}$ to 1.35 V		25°C	80	113		
				–40°C to 85°C	76			
		Sourcing $R_L = 600\ \Omega$, $V_O = 1.35\text{ V}$ to 2.2 V		25°C	80	97		
				–40°C to 85°C	76			
		Sinking $R_L = 600\ \Omega$, $V_O = 0.5\text{ V}$ to 1.35 V		25°C	80	100		
				–40°C to 85°C	76			
V_{SD}	Shutdown pin voltage	ON mode		25°C	2.4 to 2.7	2 to 2.7		V
		Shutdown mode			0 to 0.8	0 to 1		
GBWP	Gain bandwidth product			25°C		5		MHz
SR ⁽²⁾	Slew rate			25°C		5		V/ μs
Φ_m	Phase margin			25°C		60		°
V_n	Input referred voltage noise	$f = 1\text{ kHz}$		25°C		20		nV/ $\sqrt{\text{Hz}}$

(1) Shorting the output to either supply rail adversely affects reliability.

(2) Number specified is the slower of the positive and negative slew rates.

Electrical Characteristics (continued)

$V_{CC+} = 2.7\text{ V}$, $V_{CC-} = \text{GND}$, $V_{CM} = 1.35\text{ V}$, and $R_L > 1\text{ M}\Omega$ (unless otherwise noted)

PARAMETER		TEST CONDITIONS	T_A	MIN	TYP	MAX	UNIT
$T_{(on)}$	Turn-on time from shutdown		25°C		2.2	4	μs
						4.6	

Electrical Characteristics

$V_{CC+} = 5\text{ V}$, $V_{CC-} = \text{GND}$, $V_{CM} = 2.5\text{ V}$, and $R_L > 1\text{ M}\Omega$ (unless otherwise noted)

PARAMETER		TEST CONDITIONS		T_A	MIN	TYP	MAX	UNIT
V_{IO}	Input offset voltage	$V_{CM} = 0.85\text{ V}$ and 1.85 V		25°C		0.4	3	mV
				–40°C to 85°C			3.2	
I_{IB}	Input bias current			25°C		5.5	115	pA
				–40°C to 85°C			130	
CMRR	Common-mode rejection ratio	$0 \leq V_{CM} \leq 5\text{ V}$		25°C	50	80		dB
				–40°C to 85°C	45			
PSRR	Power-supply rejection ratio	$2.7\text{ V} \leq V_{CC+} \leq 5\text{ V}$	$V_{CM} = 0.85\text{ V}$	25°C	70	90		dB
				–40°C to 85°C	68			
			$V_{CM} = 1.85\text{ V}$	25°C	70	90		
				–40°C to 85°C	68			
CMVR	Common-mode voltage range	CMRR $\geq 50\text{ dB}$		25°C		–0.3	–0.2	V
						5.2	5.3	
I_{SC}	Output short-circuit current ⁽¹⁾	Sourcing $V_O = 0$		25°C	20	35		mA
				–40°C to 85°C	18			
		Sinking $V_O = 5\text{ V}$		25°C	25	50		
				–40°C to 85°C	21			
V_O	Output voltage swing	$R_L = 10\text{ k}\Omega$ to 2.5 V	V_{OH}	25°C	4.92	4.98		V
				–40°C to 85°C	4.9			
			V_{OL}	25°C		0.01	0.12	
				–40°C to 85°C			0.15	
		$R_L = 600\ \Omega$ to 2.5 V	V_{OH}	25°C	4.82	4.85		
				–40°C to 85°C	4.8			
			V_{OL}	25°C		0.05	0.23	
				–40°C to 85°C			0.3	
$V_{O(SD)}$	Output voltage level in shutdown mode			25°C		10	200	mV
I_{CC}	Supply current per channel	ON mode		25°C		1.17	1.7	mA
				–40°C to 85°C			1.9	
		Shutdown mode		25°C		0.12	1.5	μA
				–40°C to 85°C			2	
A_{VOL}	Large-signal voltage gain	Sourcing $R_L = 10\text{ k}\Omega$, $V_O = 2.5\text{ V}$ to 4.6 V		25°C	80	130		dB
				–40°C to 85°C	76			
		Sinking $R_L = 10\text{ k}\Omega$, $V_O = 0.4\text{ V}$ to 2.5 V		25°C	80	130		
				–40°C to 85°C	76			
		Sourcing $R_L = 600\ \Omega$, $V_O = 2.5\text{ V}$ to 4.6 V		25°C	80	110		
				–40°C to 85°C	76			
		Sinking $R_L = 600\ \Omega$, $V_O = 0.4\text{ V}$ to 2.5 V		25°C	80	107		
				–40°C to 85°C	76			
V_{SD}	Shutdown pin voltage	ON mode		25°C	4.5 to 5	3.5 to 5		V
		Shutdown mode			0 to 0.8	0 to 1.5		
GBWP	Gain bandwidth product			25°C		5		MHz
SR ⁽²⁾	Slew rate			25°C		5		V/ μs
Φ_m	Phase margin			25°C		60		°
V_n	Input referred voltage noise	$f = 1\text{ kHz}$		25°C		20		nV/ $\sqrt{\text{Hz}}$

(1) Shorting the output to either supply rail adversely affects reliability.

(2) Number specified is the slower of the positive and negative slew rates.

Electrical Characteristics (continued)

$V_{CC+} = 5\text{ V}$, $V_{CC-} = \text{GND}$, $V_{CM} = 2.5\text{ V}$, and $R_L > 1\text{ M}\Omega$ (unless otherwise noted)

PARAMETER		TEST CONDITIONS	T_A	MIN	TYP	MAX	UNIT
$T_{(on)}$	Turn-on time from shutdown		25°C		1.6	4	μs
						4.6	

TYPICAL CHARACTERISTICS

GRAPH PREVIEWS

Supply Current per Channel vs Supply Voltage (ON Mode)

Supply Current per Channel vs Supply Voltage (Shutdown Mode)

Input Offset Voltage vs Common-Mode Voltage

Bias Current vs Common-Mode Voltage Over Temperature

Output Positive Swing vs Supply Voltage ($R_L = 600 \Omega$)Output Negative Swing vs Supply Voltage ($R_L = 600 \Omega$)Sourcing Current vs Output Voltage ($V_{CC} = 2.7 \text{ V}$)Sourcing Current vs Output Voltage ($V_{CC} = 5 \text{ V}$)Sinking Current vs Output Voltage ($V_{CC} = 2.7 \text{ V}$)Sinking Current vs Output Voltage ($V_{CC} = 5 \text{ V}$)PSRR vs Frequency ($V_{CC} = 2.7 \text{ V}$)PSRR vs Frequency ($V_{CC} = 5 \text{ V}$)CMRR vs Frequency ($V_{CC} = 2.7 \text{ V}$)CMRR vs Frequency ($V_{CC} = 5 \text{ V}$)Open-Loop Frequency Response vs R_L ($V_{CC\pm} = 2.7 \text{ V}$)Open-Loop Frequency Response vs R_L ($V_{CC\pm} = 5 \text{ V}$)Open-Loop Frequency Response vs C_L ($V_{CC\pm} = 2.7 \text{ V}$)Open-Loop Frequency Response vs C_L ($V_{CC\pm} = 5 \text{ V}$)Voltage Noise vs Frequency ($V_{CC} = 2.7 \text{ V}$)Voltage Noise vs Frequency ($V_{CC} = 5 \text{ V}$)Non-Inverting Large Signal Pulse Response ($V_{CC} = 2.7 \text{ V}$)Non-Inverting Large Signal Pulse Response ($V_{CC} = 5 \text{ V}$)Non-Inverting Small Signal Pulse Response ($V_{CC} = 2.7 \text{ V}$)Non-Inverting Small Signal Pulse Response ($V_{CC} = 5 \text{ V}$)Inverting Large Signal Pulse Response ($V_{CC} = 2.7 \text{ V}$)Inverting Large Signal Pulse Response ($V_{CC} = 5 \text{ V}$)Inverting Small Signal Pulse Response ($V_{CC} = 2.7 \text{ V}$)Inverting Small Signal Pulse Response ($V_{CC} = 5 \text{ V}$)Turn-On Response Time ($V_{CC} = 5 \text{ V}$)Input Common-Mode Capacitance vs Common-Mode Voltage ($V_{CC} = 5 \text{ V}$)

PACKAGING INFORMATION

Orderable Device	Status (1)	Package Type	Package Drawing	Pins	Package Qty	Eco Plan (2)	Lead/Ball Finish	MSL Peak Temp (3)	Op Temp (°C)	Top-Side Markings (4)	Samples
LMV712IDGSR	OBSOLETE	VSSOP	DGS	10		TBD	Call TI	Call TI	-40 to 85	RNB	
LMV712IDGSRG4	OBSOLETE	VSSOP	DGS	10		TBD	Call TI	Call TI	-40 to 85		
LMV712IDGST	OBSOLETE	VSSOP	DGS	10		TBD	Call TI	Call TI	-40 to 85	RNB	
LMV712IDGSTG4	OBSOLETE	VSSOP	DGS	10		TBD	Call TI	Call TI	-40 to 85		

(1) The marketing status values are defined as follows:

ACTIVE: Product device recommended for new designs.

LIFEBUY: TI has announced that the device will be discontinued, and a lifetime-buy period is in effect.

NRND: Not recommended for new designs. Device is in production to support existing customers, but TI does not recommend using this part in a new design.

PREVIEW: Device has been announced but is not in production. Samples may or may not be available.

OBSOLETE: TI has discontinued the production of the device.

(2) Eco Plan - The planned eco-friendly classification: Pb-Free (RoHS), Pb-Free (RoHS Exempt), or Green (RoHS & no Sb/Br) - please check <http://www.ti.com/productcontent> for the latest availability information and additional product content details.

TBD: The Pb-Free/Green conversion plan has not been defined.

Pb-Free (RoHS): TI's terms "Lead-Free" or "Pb-Free" mean semiconductor products that are compatible with the current RoHS requirements for all 6 substances, including the requirement that lead not exceed 0.1% by weight in homogeneous materials. Where designed to be soldered at high temperatures, TI Pb-Free products are suitable for use in specified lead-free processes.

Pb-Free (RoHS Exempt): This component has a RoHS exemption for either 1) lead-based flip-chip solder bumps used between the die and package, or 2) lead-based die adhesive used between the die and leadframe. The component is otherwise considered Pb-Free (RoHS compatible) as defined above.

Green (RoHS & no Sb/Br): TI defines "Green" to mean Pb-Free (RoHS compatible), and free of Bromine (Br) and Antimony (Sb) based flame retardants (Br or Sb do not exceed 0.1% by weight in homogeneous material)

(3) MSL, Peak Temp. -- The Moisture Sensitivity Level rating according to the JEDEC industry standard classifications, and peak solder temperature.

(4) Multiple Top-Side Markings will be inside parentheses. Only one Top-Side Marking contained in parentheses and separated by a "~" will appear on a device. If a line is indented then it is a continuation of the previous line and the two combined represent the entire Top-Side Marking for that device.

Important Information and Disclaimer: The information provided on this page represents TI's knowledge and belief as of the date that it is provided. TI bases its knowledge and belief on information provided by third parties, and makes no representation or warranty as to the accuracy of such information. Efforts are underway to better integrate information from third parties. TI has taken and continues to take reasonable steps to provide representative and accurate information but may not have conducted destructive testing or chemical analysis on incoming materials and chemicals. TI and TI suppliers consider certain information to be proprietary, and thus CAS numbers and other limited information may not be available for release.

In no event shall TI's liability arising out of such information exceed the total purchase price of the TI part(s) at issue in this document sold by TI to Customer on an annual basis.

DGS (S-PDSO-G10)

PLASTIC SMALL-OUTLINE PACKAGE

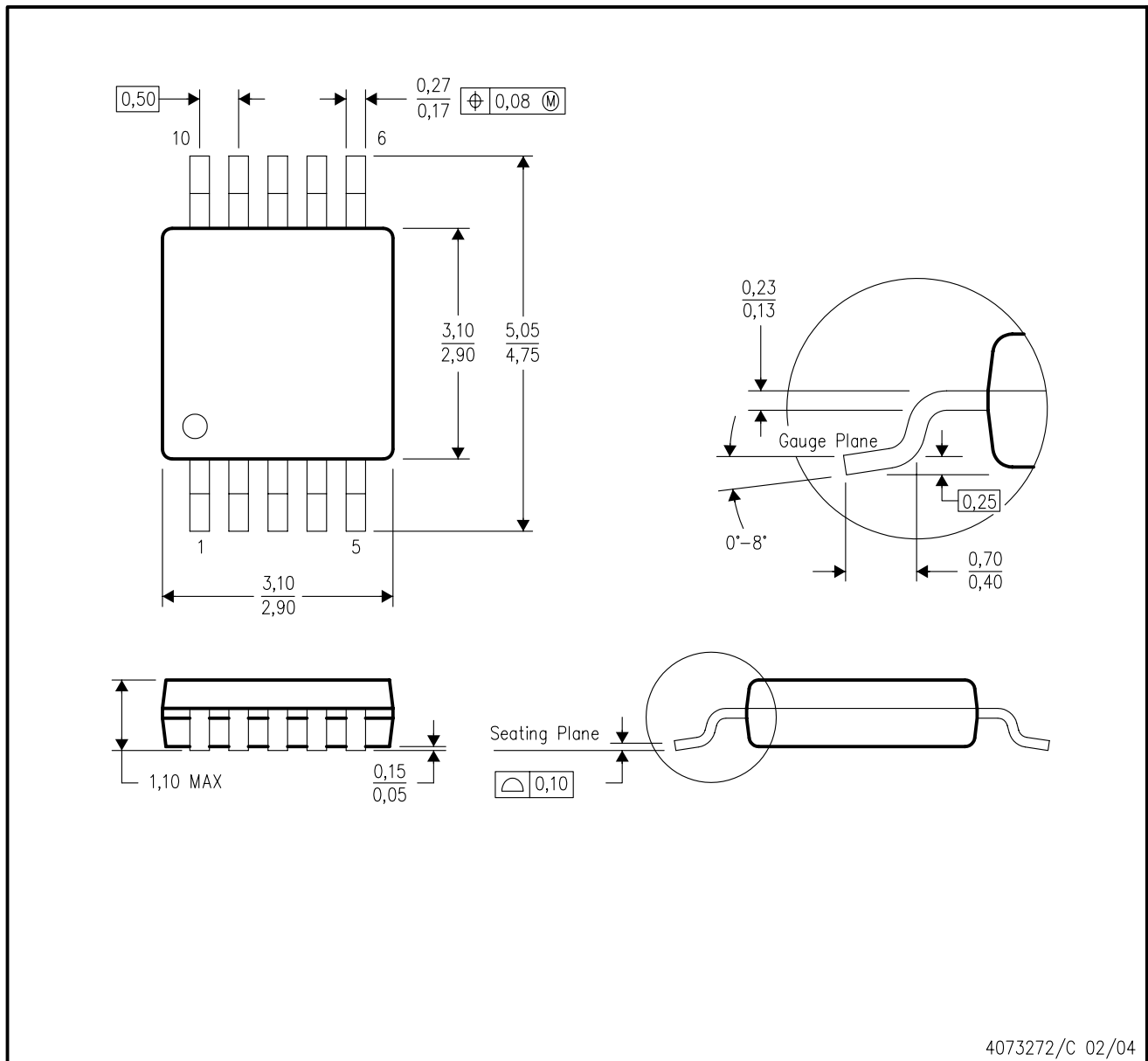

- NOTES:
- A. All linear dimensions are in millimeters.
 - B. This drawing is subject to change without notice.
 - C. Body dimensions do not include mold flash or protrusion.
 - D. Falls within JEDEC MO-187 variation BA.

IMPORTANT NOTICE

Texas Instruments Incorporated and its subsidiaries (TI) reserve the right to make corrections, enhancements, improvements and other changes to its semiconductor products and services per JESD46, latest issue, and to discontinue any product or service per JESD48, latest issue. Buyers should obtain the latest relevant information before placing orders and should verify that such information is current and complete. All semiconductor products (also referred to herein as "components") are sold subject to TI's terms and conditions of sale supplied at the time of order acknowledgment.

TI warrants performance of its components to the specifications applicable at the time of sale, in accordance with the warranty in TI's terms and conditions of sale of semiconductor products. Testing and other quality control techniques are used to the extent TI deems necessary to support this warranty. Except where mandated by applicable law, testing of all parameters of each component is not necessarily performed.

TI assumes no liability for applications assistance or the design of Buyers' products. Buyers are responsible for their products and applications using TI components. To minimize the risks associated with Buyers' products and applications, Buyers should provide adequate design and operating safeguards.

TI does not warrant or represent that any license, either express or implied, is granted under any patent right, copyright, mask work right, or other intellectual property right relating to any combination, machine, or process in which TI components or services are used. Information published by TI regarding third-party products or services does not constitute a license to use such products or services or a warranty or endorsement thereof. Use of such information may require a license from a third party under the patents or other intellectual property of the third party, or a license from TI under the patents or other intellectual property of TI.

Reproduction of significant portions of TI information in TI data books or data sheets is permissible only if reproduction is without alteration and is accompanied by all associated warranties, conditions, limitations, and notices. TI is not responsible or liable for such altered documentation. Information of third parties may be subject to additional restrictions.

Resale of TI components or services with statements different from or beyond the parameters stated by TI for that component or service voids all express and any implied warranties for the associated TI component or service and is an unfair and deceptive business practice. TI is not responsible or liable for any such statements.

Buyer acknowledges and agrees that it is solely responsible for compliance with all legal, regulatory and safety-related requirements concerning its products, and any use of TI components in its applications, notwithstanding any applications-related information or support that may be provided by TI. Buyer represents and agrees that it has all the necessary expertise to create and implement safeguards which anticipate dangerous consequences of failures, monitor failures and their consequences, lessen the likelihood of failures that might cause harm and take appropriate remedial actions. Buyer will fully indemnify TI and its representatives against any damages arising out of the use of any TI components in safety-critical applications.

In some cases, TI components may be promoted specifically to facilitate safety-related applications. With such components, TI's goal is to help enable customers to design and create their own end-product solutions that meet applicable functional safety standards and requirements. Nonetheless, such components are subject to these terms.

No TI components are authorized for use in FDA Class III (or similar life-critical medical equipment) unless authorized officers of the parties have executed a special agreement specifically governing such use.

Only those TI components which TI has specifically designated as military grade or "enhanced plastic" are designed and intended for use in military/aerospace applications or environments. Buyer acknowledges and agrees that any military or aerospace use of TI components which have **not** been so designated is solely at the Buyer's risk, and that Buyer is solely responsible for compliance with all legal and regulatory requirements in connection with such use.

TI has specifically designated certain components as meeting ISO/TS16949 requirements, mainly for automotive use. In any case of use of non-designated products, TI will not be responsible for any failure to meet ISO/TS16949.

Products

Audio	www.ti.com/audio
Amplifiers	amplifier.ti.com
Data Converters	dataconverter.ti.com
DLP® Products	www.dlp.com
DSP	dsp.ti.com
Clocks and Timers	www.ti.com/clocks
Interface	interface.ti.com
Logic	logic.ti.com
Power Mgmt	power.ti.com
Microcontrollers	microcontroller.ti.com
RFID	www.ti-rfid.com
OMAP Applications Processors	www.ti.com/omap
Wireless Connectivity	www.ti.com/wirelessconnectivity

Applications

Automotive and Transportation	www.ti.com/automotive
Communications and Telecom	www.ti.com/communications
Computers and Peripherals	www.ti.com/computers
Consumer Electronics	www.ti.com/consumer-apps
Energy and Lighting	www.ti.com/energy
Industrial	www.ti.com/industrial
Medical	www.ti.com/medical
Security	www.ti.com/security
Space, Avionics and Defense	www.ti.com/space-avionics-defense
Video and Imaging	www.ti.com/video

TI E2E Community

e2e.ti.com

Looking for pricing, stock, or lifecycle information?

Click below to explore more details on WIN SOURCE:

 [View LMV712IDGSR](#) on WIN SOURCE

 [Texas Instruments](#) Information

Optimize Your Supply Chain with WIN SOURCE Solutions

-  Global Sourcing Solution
-  Obsolete Management
-  Cost Control Management
-  Shortage Management
-  Alternative Solution
-  Excess Inventory Management