



**THE DATASHEET OF
LSF0204DPWR**



LSF0204x 4-Bits Bidirectional Multi-Voltage Level Translator for Open-Drain and Push-Pull Application

1 Features

- Provides Bidirectional Voltage Translation With No Direction Terminal
- Supports up to 100-MHz up Translation and Greater Than 100-MHz Down Translation at ≤ 30 -pF Capacitor Load and up to 40-MHz Up/Down Translation at 50-pF Capacitor Load
- Supports I_{off} , Partial Power Down Mode (Refer to [Feature Description](#))
- Allows Bidirectional Voltage Level Translation Between
 - 0.8 V \leftrightarrow 1.8, 2.5, 3.3, 5 V
 - 1.2 V \leftrightarrow 1.8, 2.5, 3.3, 5 V
 - 1.8 V \leftrightarrow 2.5, 3.3, 5 V
 - 2.5 V \leftrightarrow 3.3, 5 V
 - 3.3 V \leftrightarrow 5 V
- Low Standby Current
- 5 V Tolerance I/O Port to Support TTL
- Low R_{on} Provides Less Signal Distortion
- High-Impedance I/O Terminals For EN = Low
- Flow-Through Pinout for Ease PCB Trace Routing
- Latch-Up Performance Exceeds 100 mA Per JESD17
- -40°C to 125°C Operating Temperature Range
- ESD Performance Tested Per JESD 22
 - 2000-V Human-Body Model (A114-B, Class II)
 - 200-V Machine Model (A115-A)
 - 1000-V Charged-Device Model (C101)

2 Applications

- GPIO, MDIO, PMBus, SMBus, SDIO, UART, I²C, and Other Interfaces in Telecom Infrastructure
- Industrial
- Automotive
- Personal Computing

3 Description

The LSF family consists of bidirectional voltage level translators that operate from 0.8 V to 4.5 V (V_{ref_A}) and 1.8 V to 5.5 V (V_{ref_B}). This range allows for bidirectional voltage translations between 0.8 V and 5.0 V without the need for a direction terminal in open-drain or push-pull applications. The LSF family supports level translation applications with transmission speeds greater than 100 MHz for open-drain systems that utilize a 15-pF capacitance and 165- Ω pull-up resistor.

When the An or Bn port is LOW, the switch is in the ON-state and a low resistance connection exists between the An and Bn ports. The low R_{on} of the switch allows connections to be made with minimal propagation delay and signal distortion. The voltage on the A or B side will be limited to V_{ref_A} and can be pulled up to any level between V_{ref_A} and 5 V. This functionality allows a seamless translation between higher and lower voltages selected by the user without the need for directional control.

Device Information⁽¹⁾

PART NUMBER	PACKAGE	BODY SIZE (NOM)
LSF0204x	TSSOP (14)	5.00 mm x 4.40 mm
	UQFN (12)	2.00 mm x 1.70 mm
	VQFN (14)	3.50 mm x 3.50 mm
	DSBGA (12)	1.90 mm x 1.40 mm

(1) For all available packages, see the orderable addendum at the end of the datasheet.

Simplified Schematic

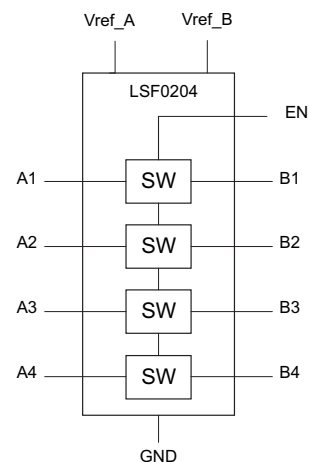

Table of Contents

1 Features	1	8.1 Load Circuit AC Waveform for Outputs	9
2 Applications	1	9 Detailed Description	10
3 Description	1	9.1 Overview	10
4 Revision History	2	9.2 Functional Block Diagram	10
5 Description (continued)	3	9.3 Feature Description	11
6 Pin Configuration and Functions	3	9.4 Device Functional Modes	11
7 Specifications	5	10 Application and Implementation	12
7.1 Absolute Maximum Ratings	5	10.1 Application Information	12
7.2 ESD Ratings	5	10.2 Typical Applications	12
7.3 Recommended Operating Conditions	5	11 Power Supply Recommendations	18
7.4 Thermal Information	5	12 Layout	18
7.5 Electrical Characteristics	6	12.1 Layout Guidelines	18
7.6 Switching Characteristics: AC Performance (Translating Down, 3.3 V to 1.8 V)	6	12.2 Layout Example	18
7.7 Switching Characteristics: AC Performance (Translating Down, 3.3 V to 1.2 V)	7	13 Device and Documentation Support	20
7.8 Switching Characteristics: AC Performance (Translating Up, 1.8 V to 3.3 V)	7	13.1 Related Links	20
7.9 Switching Characteristics: AC Performance (Translating Up, 1.2 V to 1.8 V)	7	13.2 Community Resources	20
7.10 Typical Characteristics	7	13.3 Trademarks	20
8 Parameter Measurement Information	8	13.4 Electrostatic Discharge Caution	20
		13.5 Glossary	20
		14 Mechanical, Packaging, and Orderable Information	20
		14.1 Package Option Addendum	21

4 Revision History

NOTE: Page numbers for previous revisions may differ from page numbers in the current version.

Changes from Revision E (December 2018) to Revision F	Page
• Changed location of YZP-package indicator dot to A3 position.	3
• Added YZP package to <i>Thermal Information</i> table	5
Changes from Revision D (December 2015) to Revision E	Page
• Changed location of YZP-package A1-pin indicator dot. View is looking through the device, as in an X-ray.	3
Changes from Revision C (August 2015) to Revision D	Page
• Added Type Column to <i>Pin Functions</i> table	4
• Added Junction Temperatures to <i>Thermal Information</i> table	5
Changes from Revision B (April 2015) to Revision C	Page
• Removed "Less than 1.5 ns max propagation delay" from Features.	1
• Updated "Supports High Speed Translation, Greater Than 100 MHz" bullet in Features.	1
Changes from Revision A (December 2014) to Revision B	Page
• Added YZP package to device.	1

Changes from Original (November 2014) to Revision A

Page

- Changed From a first page Product Preview To a full datasheet 1
- Changed text in the *Description* From: "transmission speeds greater than 100 Mbps" To: "transmission speeds greater than 100 MHz" 1

5 Description (continued)

The supply voltage ($V_{pu\#}$) for each channel may be individually set up with a pull up resistor. For example, CH1 may be used in up-translation mode (1.2 V ↔ 3.3 V) and CH2 in down-translation mode (2.5 V ↔ 1.8 V).

When EN is HIGH, the translator switch is on, and the An I/O is connected to the Bn I/O, respectively, allowing bidirectional data flow between ports. When EN is LOW, the translator switch is off, and a high-impedance state exists between ports. The EN input circuit is designed to be supplied by Vref_A. EN must be LOW to ensure the high-impedance state during power-up or power-down.

Device Comparison Table

PART NUMBER	EN	An	Bn	DESCRIPTION
LSF0204D	H	Place all data pins in 3 state mode (Hi-Z)	Place all data pins in 3 state mode (Hi-Z)	3-state output mode enable (active Low; referenced to Vref_A)
LSF0204D	L	Input or output	Input or output	
LSF0204	H	Input or output	Input or output	3-state output mode enable (active High, referenced to Vref_A)
LSF0204	L	Place all data pins in 3 state mode (Hi-Z)	Place all data pins in 3 state mode (Hi-Z)	

6 Pin Configuration and Functions

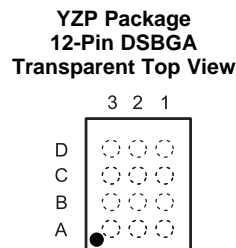
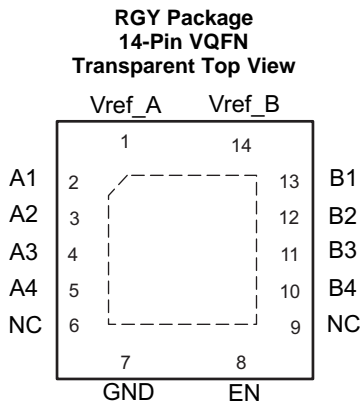
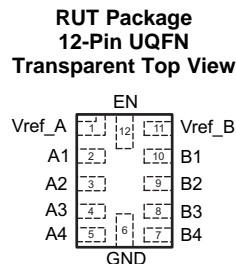
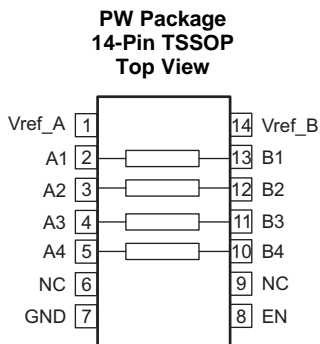

Pin Functions

NAME	PIN			TYPE	DESCRIPTION
	NO.				
	PW, RGY	RUT	YZP		
V _{ref_A}	1	1	B2	--	Reference supply voltage; see Application and Implementation section
A1	2	2	A3	I/O	Input/output 1.
A2	3	3	B3	I/O	Input/output 2.
A3	4	4	C3	I/O	Input/output 3.
A4	5	5	D3	I/O	Input/output 4.
NC	6	–	–	--	No connection. Not internally connected.
GND	7	6	D2	--	Ground
EN	8	12	C2	I	Switch enable input; LSF0204: EN is high-active; LSF0204D: EN is low-active
NC	9	–	–	--	No connection. Not internally connected.
B4	10	7	D1	I/O	Input/output 4.
B3	11	8	C1	I/O	Input/output 3.
B2	12	9	B1	I/O	Input/output 2.
B1	13	10	A1	I/O	Input/output 1.
V _{ref_B}	14	11	A2	--	Reference supply voltage; see Application and Implementation section

7 Specifications

7.1 Absolute Maximum Ratings

over operating free-air temperature range (unless otherwise noted) ⁽¹⁾

	MIN	MAX	UNIT
V _I Input voltage ⁽²⁾	-0.5	7	V
V _{I/O} Input/output voltage ⁽²⁾	-0.5	7	V
Continuous channel current		128	mA
I _{IK} Input clamp current	VI < 0	-50	mA
T _J Junction temperature		150	°C
T _{stg} Storage temperature	-65	150	°C

- Stresses beyond those listed under *Absolute Maximum Ratings* may cause permanent damage to the device. These are stress ratings only, which do not imply functional operation of the device at these or any other conditions beyond those indicated under *Recommended Operating Conditions*. Exposure to absolute-maximum-rated conditions for extended periods may affect device reliability.
- The input and input/output negative-voltage ratings may be exceeded if the input and input/output clamp-current ratings are observed.

7.2 ESD Ratings

	VALUE	UNIT
V _(ESD) Electrostatic discharge	Human-body model (HBM), per ANSI/ESDA/JEDEC JS-001 ⁽¹⁾	±2000
	Charged-device model (CDM), per JEDEC specification JESD22-C101 ⁽²⁾	±1000

- JEDEC document JEP155 states that 500-V HBM allows safe manufacturing with a standard ESD control process. Manufacturing with less than 500-V HBM is possible with the necessary precautions.
- JEDEC document JEP157 states that 250-V CDM allows safe manufacturing with a standard ESD control process. Manufacturing with less than 250-V CDM is possible with the necessary precautions.

7.3 Recommended Operating Conditions

over operating free-air temperature range (unless otherwise noted)

	MIN	MAX	UNIT
V _{I/O} Input/output voltage	0	5	V
V _{ref_A/B/EN} Reference voltage	0	5	V
I _{PASS} Pass transistor current		64	mA
T _A Operating free-air temperature	-40	125	°C

7.4 Thermal Information

THERMAL METRIC ⁽¹⁾	LSF0204				UNIT
	RGY (VQFN)	RUT (UQFN)	PW (TSSOP)	YZP (DSBGA)	
	14 PINS	12 PINS	14 PINS	12 BALLS	
R _{θJA} Junction-to-ambient thermal resistance	83.2	195.8	157.9	83.7	°C
R _{θJC(top)} Junction-to-case (top) thermal resistance	98.2	98.7	82.3	0.6	°C
R _{θJB} Junction-to-board thermal resistance	59.2	122.6	100.0	23.7	°C
ψ _{JT} Junction-to-top characterization parameter	17.4	6.2	22.9	0.4	°C
ψ _{JB} Junction-to-board characterization parameter	59.4	122.6	99.0	23.7	°C
R _{θJC(bot)} Junction-to-case (bottom) thermal resistance	38.7	N/A	N/A	N/A	°C

- For more information about traditional and new thermal metrics, see the *Semiconductor and IC Package Thermal Metrics* application report, [SPRA953](#).

7.5 Electrical Characteristics

over recommended operating free-air temperature range (unless otherwise noted)

PARAMETER		TEST CONDITIONS	MIN	TYP ⁽¹⁾	MAX	UNIT
V_{IK}		$I_I = -18 \text{ mA}$, $V_{EN} = 0$			-1.2	V
I_{IH}		$V_I = 5 \text{ V}$, $V_{EN} = 0$			5.0	μA
I_{CCBA}	Leakage from Vref_B to Vref_A	$V_{ref_B} = 3.3 \text{ V}$, $V_{ref_A} = 1.8 \text{ V}$, $V_{EN} = V_{ref_A}$, $I_O = 0$, $V_I = 3.3 \text{ V}$ or GND			3.5	μA
$I_{CCA} + I_{CCB}$ ⁽²⁾	Total Current through GND	$V_{ref_B} = 3.3 \text{ V}$, $V_{ref_A} = 1.8 \text{ V}$, $V_{EN} = V_{ref_A}$, $I_O = 0$, $V_I = 3.3 \text{ V}$ or GND		0.2		μA
I_{IN}	Control pin current	$V_{ref_B} = 5.5 \text{ V}$, $V_{ref_A} = 4.5 \text{ V}$, $V_{EN} = 0$ to V_{ref_A} , $I_O = 0$			± 1	μA
I_{off}	Power Off Leakage Current	$V_{ref_B} = V_{ref_A} = 0 \text{ V}$, $V_{EN} = \text{GND}$, $I_O = 0$, $V_I = 5 \text{ V}$ or GND			± 1	μA
$C_{I(ref_A/B/EN)}$		$V_I = 3 \text{ V}$ or 0		7		pF
$C_{Io(off)}$		$V_O = 3 \text{ V}$ or 0, $V_{EN} = 0$		5.0	6.0	pF
$C_{Io(on)}$		$V_O = 3 \text{ V}$ or 0, $V_{EN} = V_{ref_A}$		10.5	13	pF
⁽³⁾ V_{IH} (EN pin)	High-level input voltage	$V_{ref_A} = 1.5 \text{ V}$ to 4.5 V		$0.7 \times V_{ref_A}$		V
V_{IL} (EN pin)	Low-level input voltage	$V_{ref_A} = 1.5 \text{ V}$ to 4.5 V			$0.3 \times V_{ref_A}$	V
V_{IH} (EN pin)	High-level input voltage	$V_{ref_A} = 1.0 \text{ V}$ to 1.5 V		$0.8 \times V_{ref_A}$		V
V_{IL} (EN pin)	Low-level input voltage	$V_{ref_A} = 1.0 \text{ V}$ to 1.5 V			$0.3 \times V_{ref_A}$	V
$\Delta t/\Delta v$ (EN pin)	Input transition rise or fall rate for EN pin			10		ns/V
r_{on} ⁽⁴⁾	$V_I = 0$, $I_O = 64 \text{ mA}$	$V_{ref_A} = V_{EN} = 3.3 \text{ V}$; $V_{ref_B} = 5 \text{ V}$		3		Ω
		$V_{ref_A} = V_{EN} = 1.8 \text{ V}$; $V_{ref_B} = 5 \text{ V}$		4		
	$V_I = 0$, $I_O = 32 \text{ mA}$	$V_{ref_A} = V_{EN} = 1.0 \text{ V}$; $V_{ref_B} = 5 \text{ V}$		9		Ω
		$V_{ref_A} = V_{EN} = 1.8 \text{ V}$; $V_{ref_B} = 5 \text{ V}$		4		
	$V_I = 0$, $I_O = 32 \text{ mA}$, $V_{ref_A} = V_{EN} = 2.5 \text{ V}$; $V_{ref_B} = 5 \text{ V}$			10		Ω
	$V_I = 1.8 \text{ V}$, $I_O = 15 \text{ mA}$, $V_{ref_A} = V_{EN} = 3.3 \text{ V}$; $V_{ref_B} = 5 \text{ V}$			5		Ω
	$V_I = 1.0 \text{ V}$, $I_O = 10 \text{ mA}$, $V_{ref_A} = V_{EN} = 1.8 \text{ V}$; $V_{ref_B} = 3.3 \text{ V}$			8		Ω
	$V_I = 0 \text{ V}$, $I_O = 10 \text{ mA}$, $V_{ref_A} = V_{EN} = 1.0 \text{ V}$; $V_{ref_B} = 3.3 \text{ V}$			6		Ω
$V_I = 0 \text{ V}$, $I_O = 10 \text{ mA}$, $V_{ref_A} = V_{EN} = 1.0 \text{ V}$; $V_{ref_B} = 1.8 \text{ V}$			6		Ω	

 (1) All typical values are at $T_A = 25^\circ\text{C}$.

 (2) The actual supply current for LSF0204 is $I_{CCA} + I_{CCB}$; the leakage from Vref_B to Vref_A can be measured on Vref_A and Vref_B pin

(3) Enable pin test conditions are for the LSF0204. The enable pin test conditions for LSF0204D are oppositely set.

(4) Measured by the voltage drop between the A and B terminals at the indicated current through the switch. On-state resistance is determined by the lowest voltage of the two (A or B) terminals.

7.6 Switching Characteristics: AC Performance (Translating Down, 3.3 V to 1.8 V)

 over recommended operating free-air temperature range, $V_{rev-A} = 1.8 \text{ V}$, $V_{rev-B} = 3.3 \text{ V}$, $V_{EN} = 1.8 \text{ V}$, $V_{pu_1} = 3.3 \text{ V}$, $V_{pu_2} = 1.8 \text{ V}$, $R_L = \text{NA}$, $V_{IH} = 3.3 \text{ V}$, $V_{IL} = 0 \text{ V}$, $V_M = 1.15 \text{ V}$ (unless otherwise noted)

PARAMETER	FROM (INPUT)	TO (OUTPUT)	$C_L = 50 \text{ pF}$		$C_L = 30 \text{ pF}$		$C_L = 15 \text{ pF}$		UNIT
			TYP	MAX	TYP	MAX	TYP	MAX	
t_{PLH}	A or B	B or A	0.7	5.49	0.5	5.29	0.3	5.19	ns
t_{PHL}			0.9	4.9	0.7	4.7	0.5	4.5	ns
t_{PLZ}			13	18	12	16.5	11	15	ns
t_{PZL}			33	45	30	40	23	37	ns
f_{MAX}			50		100		100		MHz

7.7 Switching Characteristics: AC Performance (Translating Down, 3.3 V to 1.2 V)

over recommended operating free-air temperature range $V_{rev-A} = 1.2\text{ V}$, $V_{rev-B} = 3.3\text{ V}$, $V_{EN} = 1.2\text{ V}$, $V_{pu_1} = 3.3\text{ V}$, $V_{pu_2} = 1.2\text{ V}$, $R_L = NA$, $V_{IH} = 3.3\text{ V}$, $V_{IL} = 0\text{ V}$, $V_M = 0.85\text{ V}$ (unless otherwise noted)

PARAMETER	FROM (INPUT)	TO (OUTPUT)	$C_L = 50\text{ pF}$		$C_L = 30\text{ pF}$		$C_L = 15\text{ pF}$		UNIT
			TYP	MAX	TYP	MAX	TYP	MAX	
t_{PLH}	A or B	B or A	0.8	4.1	0.5	3.9	0.3	3.8	ns
t_{PHL}			0.9	4.7	0.7	4.5	0.6	4.3	ns
f_{MAX}			50		100		100		MHz

7.8 Switching Characteristics: AC Performance (Translating Up, 1.8 V to 3.3 V)

over recommended operating free-air temperature range $V_{rev-A} = 1.8\text{ V}$, $V_{rev-B} = 3.3\text{ V}$, $V_{EN} = 1.8\text{ V}$, $V_{pu_1} = 3.3\text{ V}$, $V_{pu_2} = 1.8\text{ V}$, $R_L = 500\ \Omega$, $V_{IH} = 1.8\text{ V}$, $V_{IL} = 0\text{ V}$, $V_M = 0.9\text{ V}$ (unless otherwise noted)

PARAMETER	FROM (INPUT)	TO (OUTPUT)	$C_L = 50\text{ pF}$		$C_L = 30\text{ pF}$		$C_L = 15\text{ pF}$		UNIT
			TYP	MAX	TYP	MAX	TYP	MAX	
t_{PLH}	A or B	B or A	0.6	5.7	0.4	5.3	0.2	5.13	ns
t_{PHL}			1.3	6.7	1	6.4	0.7	5.3	ns
t_{PLZ}			13	18	12	16.5	11	15	ns
t_{PZL}			33	45	30	40	23	37	ns
f_{MAX}			50		100		100		MHz

7.9 Switching Characteristics: AC Performance (Translating Up, 1.2 V to 1.8 V)

over recommended operating free-air temperature range, $V_{rev-A} = 1.2\text{ V}$, $V_{rev-B} = 1.8\text{ V}$, $V_{EN} = 1.2\text{ V}$, $V_{pu_1} = 1.8\text{ V}$, $V_{pu_2} = 1.2\text{ V}$, $R_L = 500\ \Omega$, $V_{IH} = 1.2\text{ V}$, $V_{IL} = 0\text{ V}$, $V_M = 0.6\text{ V}$ (unless otherwise noted)

PARAMETER	FROM (INPUT)	TO (OUTPUT)	$C_L = 50\text{ pF}$		$C_L = 30\text{ pF}$		$C_L = 15\text{ pF}$		UNIT
			TYP	MAX	TYP	MAX	TYP	MAX	
t_{PLH}	A or B	B or A	0.65	7.25	0.4	7.05	0.2	6.85	ns
t_{PHL}			1.6	7.03	1.3	6.5	1	5.4	ns
f_{MAX}			50		100		100		MHz

7.10 Typical Characteristics

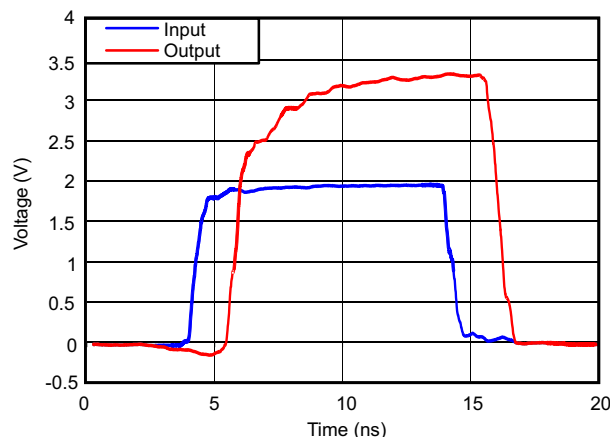
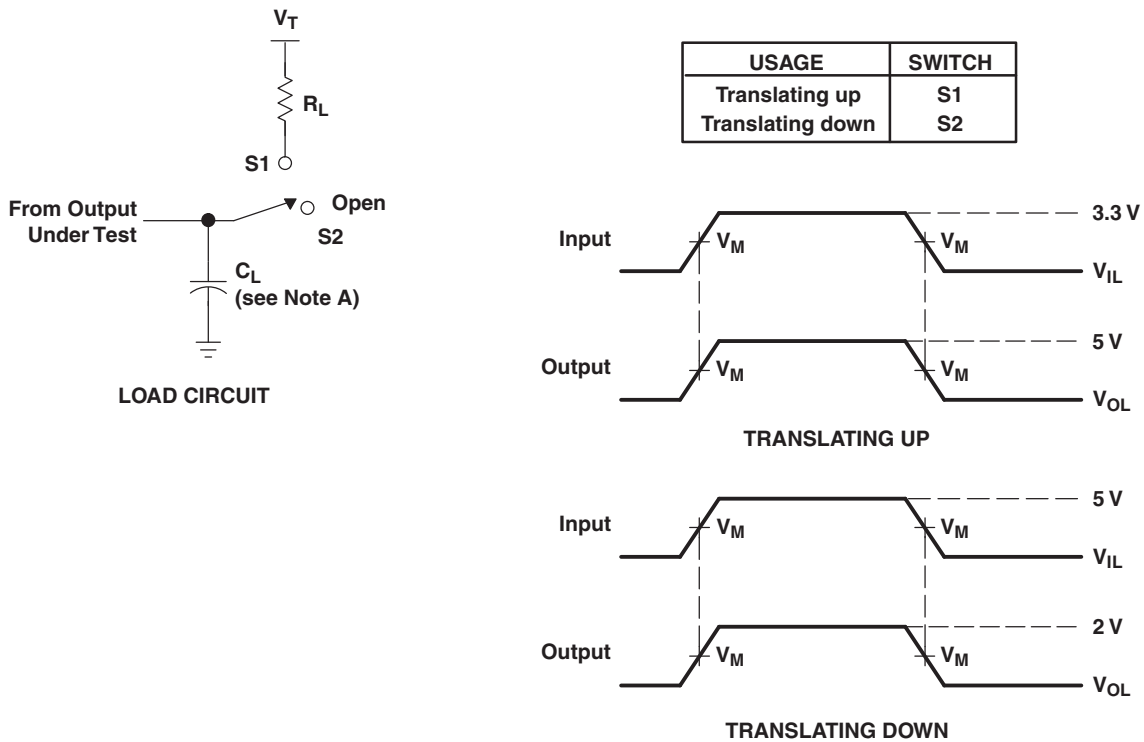

Figure 1. Signal Integrity (1.8 V to 3.3 V Translation Up at 50 MHz)

8 Parameter Measurement Information



- NOTES: A. C_L includes probe and jig capacitance.
 B. All input pulses are supplied by generators having the following characteristics: $PRR \leq 10 \text{ MHz}$, $Z_O = 50 \Omega$, $t_r \leq 2 \text{ ns}$, $t_f \leq 2 \text{ ns}$.
 C. The outputs are measured one at a time, with one transition per measurement.

Figure 2. Load Circuit for Outputs

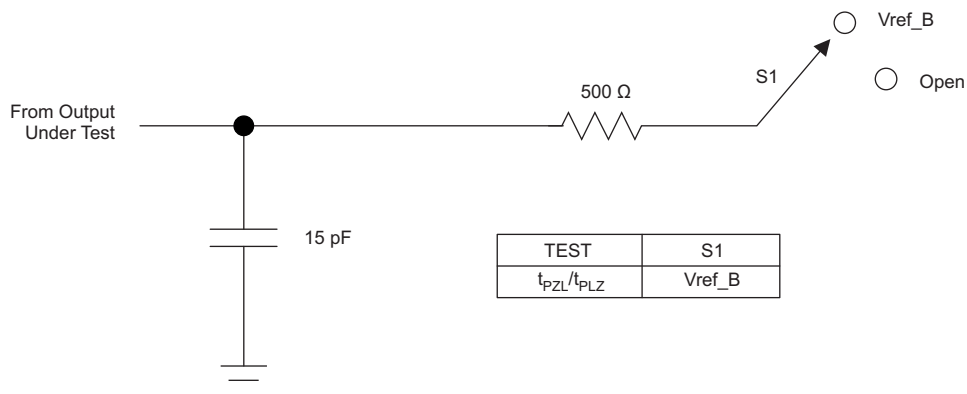

Figure 3. Load Circuit for Enable/Disable Time Measurement

8.1 Load Circuit AC Waveform for Outputs

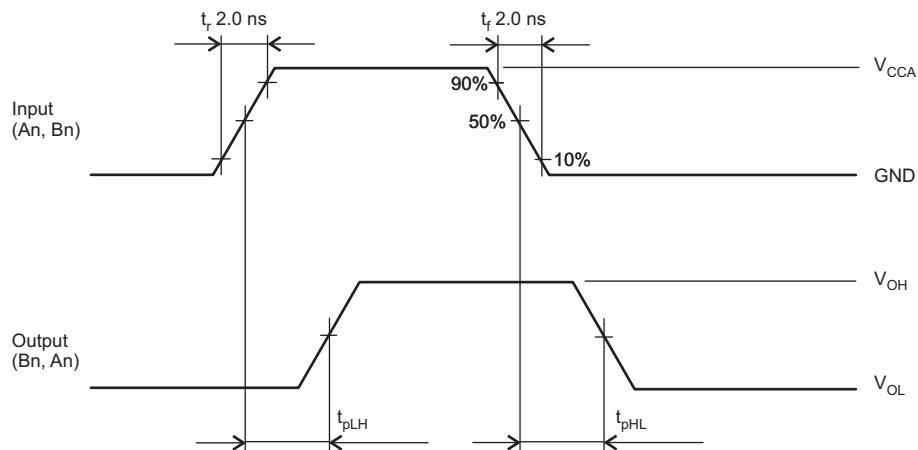

Figure 4. t_{pLH} , t_{pHL}

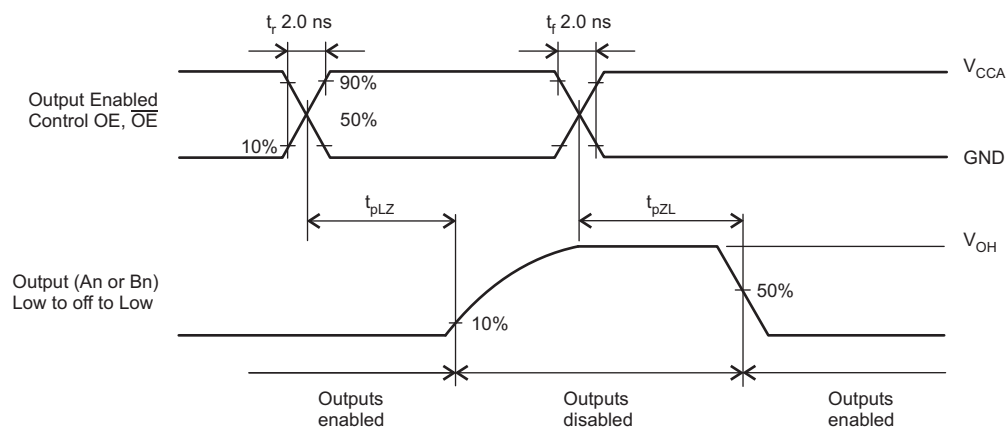

Figure 5. t_{pLZ} , t_{pZL}

9 Detailed Description

9.1 Overview

The LSF Family may be used in level translation applications for interfacing devices or systems operating at different interface voltages with one another. The LSF Family is ideal for use in applications where an open-drain driver is connected to the data I/Os. LSF can achieve 100 MHz with the appropriate pull-up resistors and layout. The LSF Family may also be used in applications where a push-pull driver is connected to the data I/Os.

9.2 Functional Block Diagram

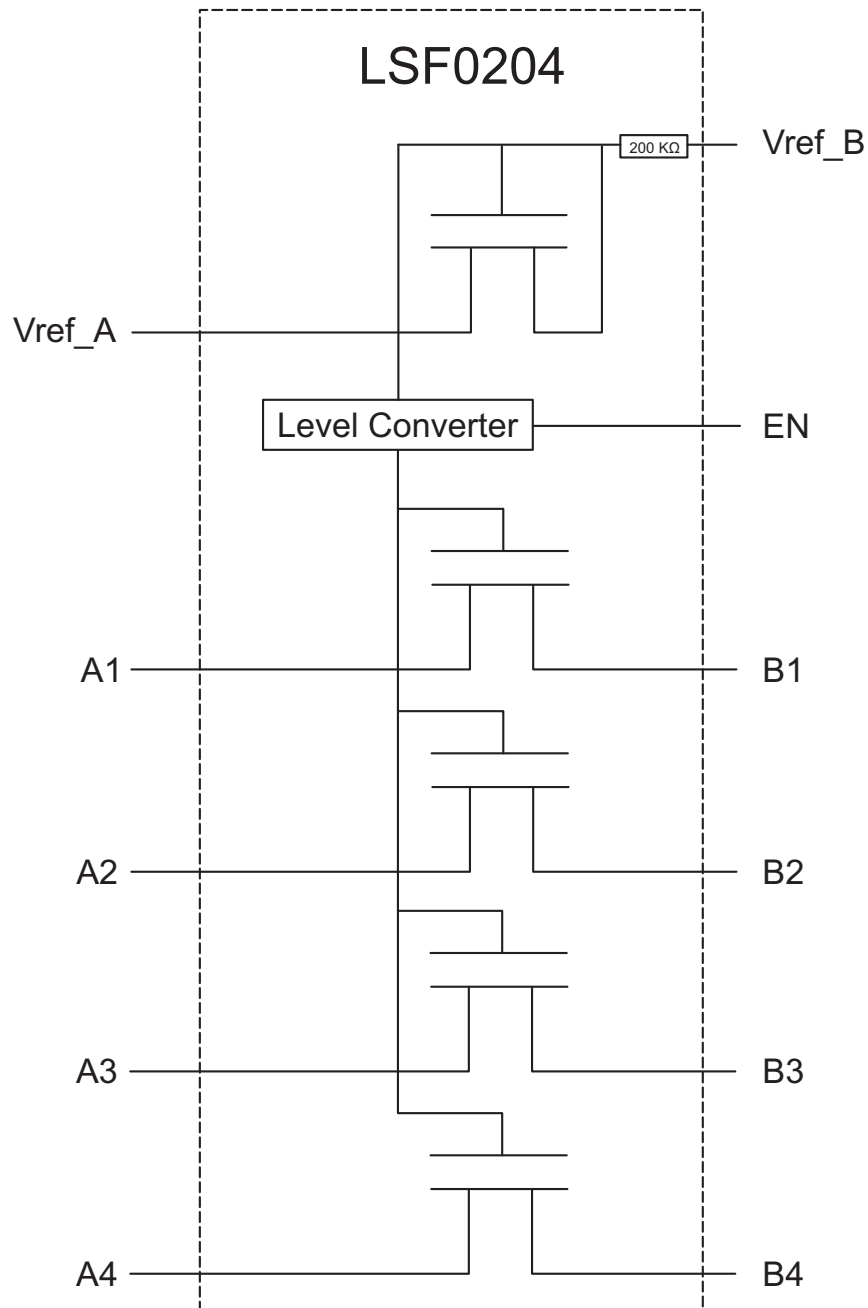

9.3 Feature Description

9.3.1 Support High Speed Translation, Greater than 100 MHz

Allows the LSF family to support more consumer or telecom interfaces (MDIO or SDIO).

9.3.2 Bidirectional Voltage Translation Without DIR Terminal

Minimizes system effort to develop voltage translation for bidirectional interface (PMBus, I2C, or SMBus).

9.3.3 5-V Tolerance on IO Port and 125°C Support

The LSF family, with 5-V tolerance and 125°C support, is flexible and compliant with TTL levels in industrial and telecom applications.

9.3.4 Channel Specific Translation

The LSF family is able to set up different voltage translation levels on each channel.

9.3.5 Ioff, Partial Power Down Mode

When V_{ref_A} , $V_{ref_B} = 0$, all of data pins and EN pin are Hi-Z.

EN logic circuit is supplied by V_{ref_A} , once V_{ref_A} power up first and all of data pins are unknown state until V_{ref_B} and EN ready. No power sequence is required to enable LSF0204 and operate function normally.

9.4 Device Functional Modes

[Table 1](#) lists the device functional modes of the LSF0204x family of devices.

Table 1. Function Table

INPUT EN ⁽¹⁾ TERMINAL	FUNCTION
H	An = Bn
L	Hi-Z

(1) EN is controlled by V_{ref_A} logic levels.

10 Application and Implementation

NOTE

Information in the following applications sections is not part of the TI component specification, and TI does not warrant its accuracy or completeness. TI's customers are responsible for determining suitability of components for their purposes. Customers should validate and test their design implementation to confirm system functionality.

10.1 Application Information

LSF performs voltage translation for open-drain or push-pull interface. [Table 2](#) provides some consumer/telecom interfaces as reference in regards to the different channel numbers that are supported by the LSF family.

Table 2. Voltage Translator for Consumer/Telecom Interface

PART NAME	CH#	INTERFACE
LSF0101	1	GPIO
LSF0102	2	GPIO, MDIO, SMBus, PMBus, I2C
LSF0204	4	GPIO, SPI, MDIO, SMBus, PMBus, I2C, UART, SVID
LSF0108	8	GPIO, MDIO, SDIO, SVID, UART, SMBus, PMBus, I2C, SPI

10.2 Typical Applications

10.2.1 I²C PMBus, SMBus, GPIO, Application

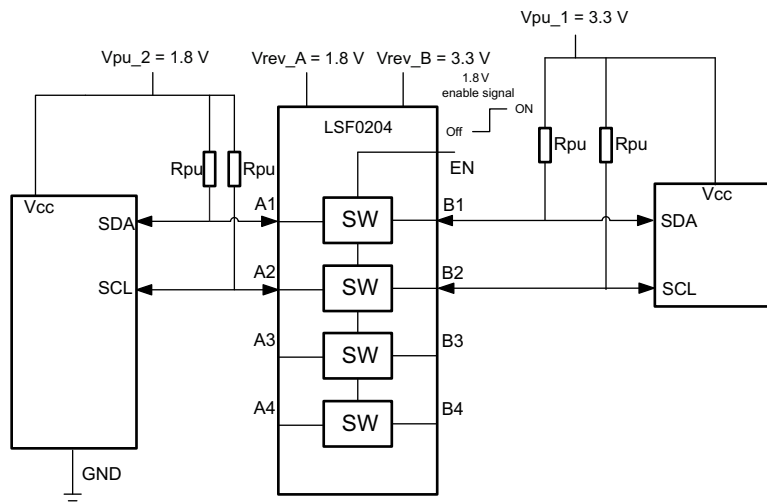

Figure 6. Bidirectional Translation to Multiple Voltage Levels

10.2.1.1 Design Requirements

10.2.1.1.1 Enable, Disable, and Reference Voltage Guidelines

The LSF family has an EN input that is used to disable the device by setting EN LOW, which places all I/Os in the high-impedance state. Since LSF family is switch-type voltage translator, the power consumption is very low. It is recommended to always enable LSF family for bidirectional application (I2C, SMBus, PMBus, or MDIO).

Typical Applications (continued)

Table 3. Application Operating Condition

SYMBOL	PARAMETER	MIN	TYP	MAX	UNIT
Vref_A	Reference voltage (A)	0.8		4.5	V
Vref_B	Reference voltage (B)	Vref_A + 0.8		5.5	V
V _{I(EN)} ⁽¹⁾	Input voltage on EN terminal	0		Vref_A	V
Vpu	Pull-up supply voltage	0		Vref_B	V

(1) Refer V_{IH} and V_{IL} for V_{I(EN)}

Also Vref_B is recommended to be at 1.0 V higher than Vref_A for best signal integrity.

The LSF Family is able to set different voltage translation level on each channel.

NOTE

Vref_A must be set as lowest voltage level.

10.2.1.2 Detailed Design Procedure

10.2.1.2.1 Bidirectional Translation

The master output driver may be push-pull or open-drain (pull-up resistors may be required) and the slave device output can be push-pull or open-drain (pull-up resistors are required to pull the Bn outputs to Vpu).

NOTE

However, if either output is push-pull, data must be unidirectional or the outputs must be 3-state and be controlled by some direction-control mechanism to prevent HIGH-to-LOW contentions in either direction. If both outputs are open-drain, no direction control is needed.

In [Figure 6](#), the reference supply voltage (Vref_A) is connected to the processor core power supply voltage. When Vref_B is connected through to a 3.3 V Vpu power supply, and Vref_A is set 1.0V. The output of A3 and B4 has a maximum output voltage equal to Vref_A, and the bidirectional interface (Ch1/2, MDIO) has a maximum output voltage equal to Vpu.

10.2.1.2.1.1 Pull-up Resistor Sizing

The pull-up resistor value needs to limit the current through the pass transistor when it is in the ON state to about 15 mA. This ensures a pass voltage of 260 mV to 350 mV. If the current through the pass transistor is higher than 15 mA, the pass voltage also is higher in the ON state. To set the current through each pass transistor at 15 mA, to calculate the pull-up resistor value use [Equation 1](#).

$$R_{pu} = (V_{pu} - 0.35 \text{ V}) / 0.015 \text{ A} \quad (1)$$

[Table 4](#) summarizes resistor values, reference voltages, and currents at 15 mA, 10 mA, and 3 mA. The resistor value shown in the +10% column (or a larger value) should be used to ensure that the pass voltage of the transistor is 350 mV or less. The external driver must be able to sink the total current from the resistors on both sides of the LSF family device at 0.175 V, although the 15 mA applies only to current flowing through the LSF family device.

Table 4. Pullup Resistor Values⁽¹⁾⁽²⁾

V _{DPU}	PULLUP RESISTOR VALUE (Ω)					
	15 mA NOMINAL	10 mA +10% ⁽³⁾	3 mA NOMINAL	3 mA +10% ⁽³⁾	NOMINAL	+10% ⁽³⁾
5 V	310	341	465	512	1550	1705
3.3 V	197	217	295	325	983	1082
2.5 V	143	158	215	237	717	788
1.8 V	97	106	145	160	483	532
1.5 V	77	85	115	127	383	422
1.2 V	57	63	85	94	283	312

- (1) Calculated for V_{OL} = 0.35 V
- (2) Assumes output driver V_{OL} = 0.175 V at stated current
- (3) +10% to compensate for V_{DD} range and resistor tolerance

10.2.1.2.2 LS Family Bandwidth

The maximum frequency of the LSF family is dependent on the application. The device may operate at speeds of >100MHz given the correct conditions. The maximum frequency is dependent upon the loading of the application. The LSF family behaves like a standard switch where the bandwidth of the device is dictated by the on resistance and on capacitance of the device.

Figure 7 shows a bandwidth measurement of the LSF family using a two-port network analyzer.

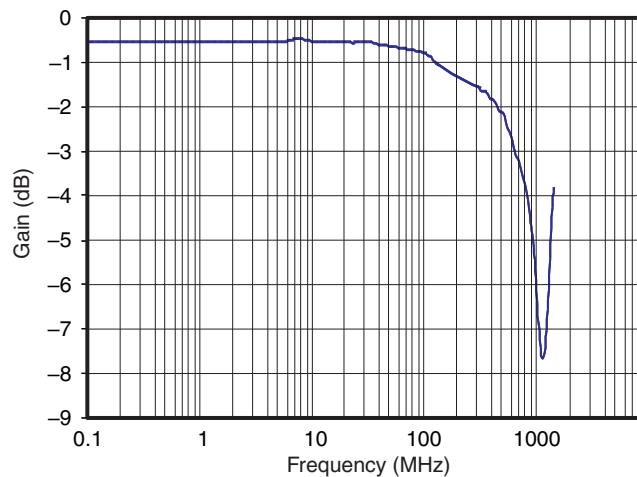

Figure 7. 3-dB Bandwidth

The 3-dB point of the LSF family is ≈600MHz; however, this measurement is an analog type of measurement. For digital applications, the signal should not degrade up to the fifth harmonic of the digital signal. The frequency bandwidth should be at least five times the maximum digital clock rate. This component of the signal is important in determining the overall shape of the digital signal. In the case of the LSF family, a digital clock frequency of greater than 100 MHz may be achieved.

The LSF family does not provide any drive capability. Therefore higher frequency applications will require higher drive strength from the host side. No pullup resistor is needed on the host side (3.3 V) if the LSF family is being driven by standard CMOS totem pole output driver. Best practice is to minimize the trace length from the LSF family on the sink side (1.8 V) to minimize signal degradation.

All fast edges have an infinite spectrum of frequency components; however, there is an inflection (or *knee*) in the frequency spectrum of fast edges where frequency components higher than f_{knee} are insignificant in determining the shape of the signal.

To calculate the maximum *practical* frequency component, or the *knee* frequency (f_{knee}), use the following equations:

$$f_{knee} = 0.5/RT \text{ (10–80\%)} \tag{2}$$

$$f_{knee} = 0.4/RT \text{ (20–80\%)} \tag{3}$$

For signals with rise time characteristics based on 10- to 90-percent thresholds, f_{knee} is equal to 0.5 divided by the rise time of the signal. For signals with rise time characteristics based on 20% to 80% thresholds, which is very common in many of today's device specifications, f_{knee} is equal to 0.4 divided by the rise time of the signal.

Some guidelines to follow that will help maximize the performance of the device:

- Keep trace length to a minimum by placing the LSF family close to the I²C output of the processor.
- The trace length should be less than half the time of flight to reduce ringing and line reflections or non-monotonic behavior in the switching region.
- To reduce overshoots, a pullup resistor can be added on the 1.8 V side; be aware that a slower fall time is to be expected.

10.2.1.3 Application Curve

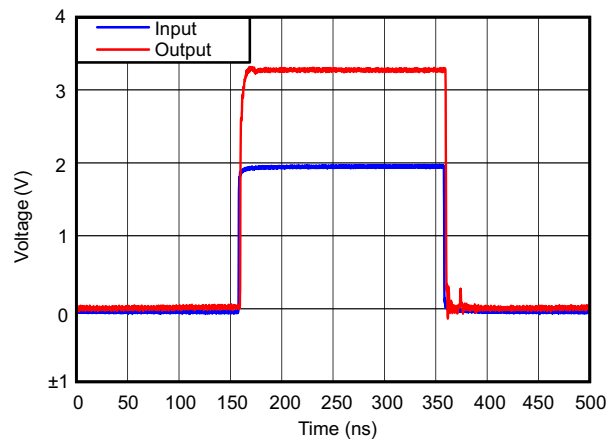

Figure 8. Captured Waveform From Above I²C Set-Up (1.8 V to 3.3 V at 2.5 MHz)

10.2.2 MDIO Application

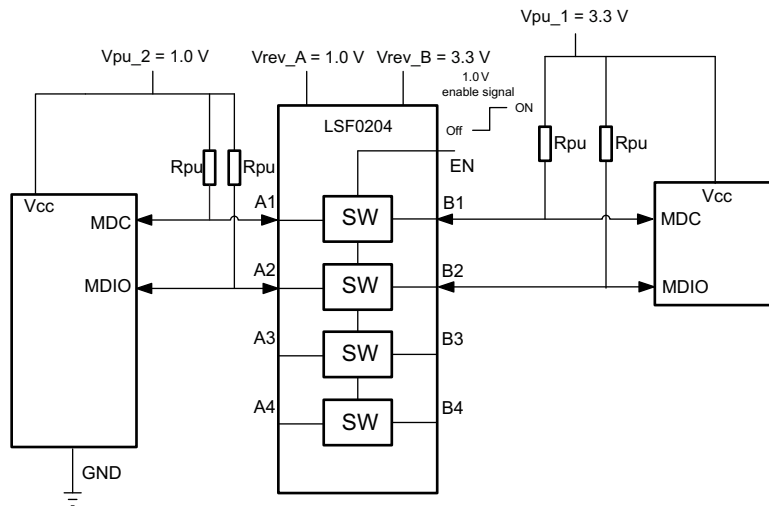

Figure 9. Typical Application Circuit (MDIO/Bidirectional Interface)

10.2.2.1 Design Requirements

Refer to [Design Requirements](#).

10.2.2.2 Detailed Design Procedure

Refer to [Detailed Design Procedure](#)

10.2.2.3 Application Curve

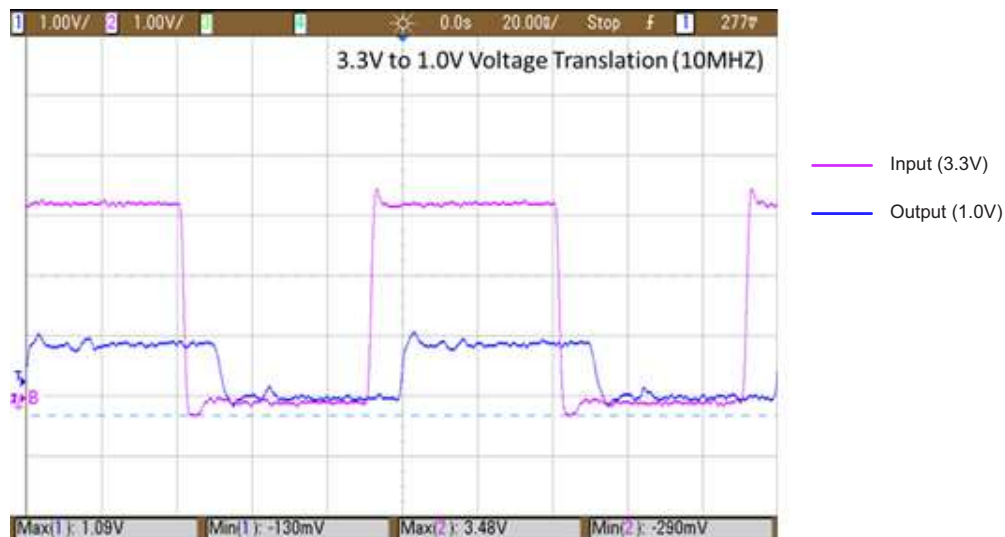
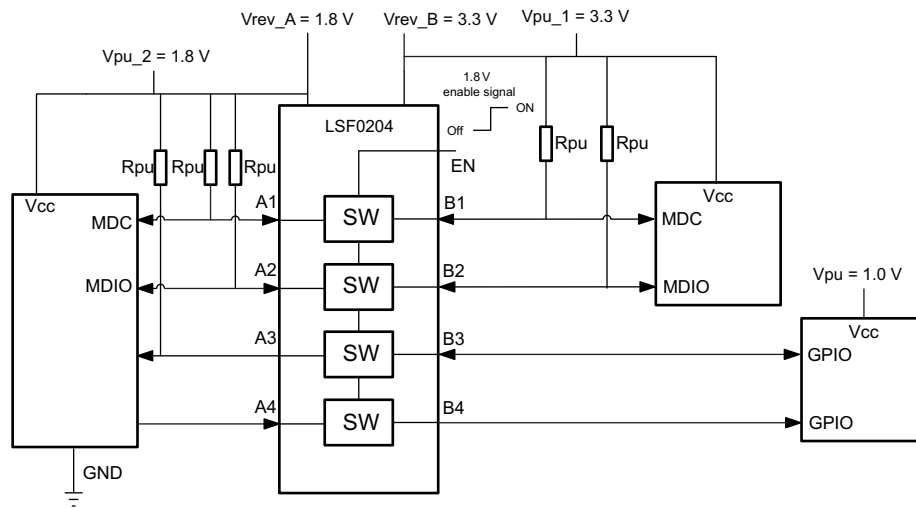

Figure 10. Captured Waveform From Above MDIO Setup

10.2.3 Multiple Voltage Translation in Single Device, Application



10.2.3.1 Design Requirements

Refer to [Design Requirements](#).

10.2.3.2 Detailed Design Procedure

Refer to [Detailed Design Procedure](#)

10.2.3.3 Application Curve

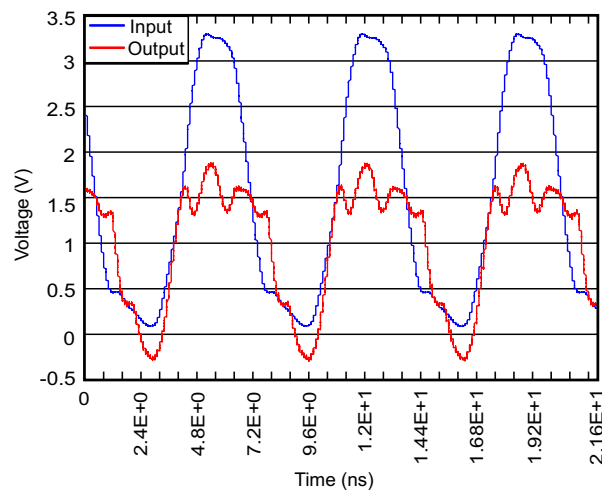

Figure 11. Translation Down (3.3 V to 1.8 V) at 150 MHz

11 Power Supply Recommendations

There are no power sequence requirements for the LSF Family. Refer to the [Enable, Disable, and Reference Voltage Guidelines](#) for enabling and reference voltage guidelines.

12 Layout

12.1 Layout Guidelines

The signal integrity is highly related with pull-up resistor and PCB capacitance condition because LSF Family is switch-type level translator

- Short signal trace as possible to reduce capacitance and minimize stub from pull-up resistor.
- Place LSF close to high voltage side.
- Select the appropriate pull-up resistor that applies to translation levels and driving capability of transmitter.

12.2 Layout Example

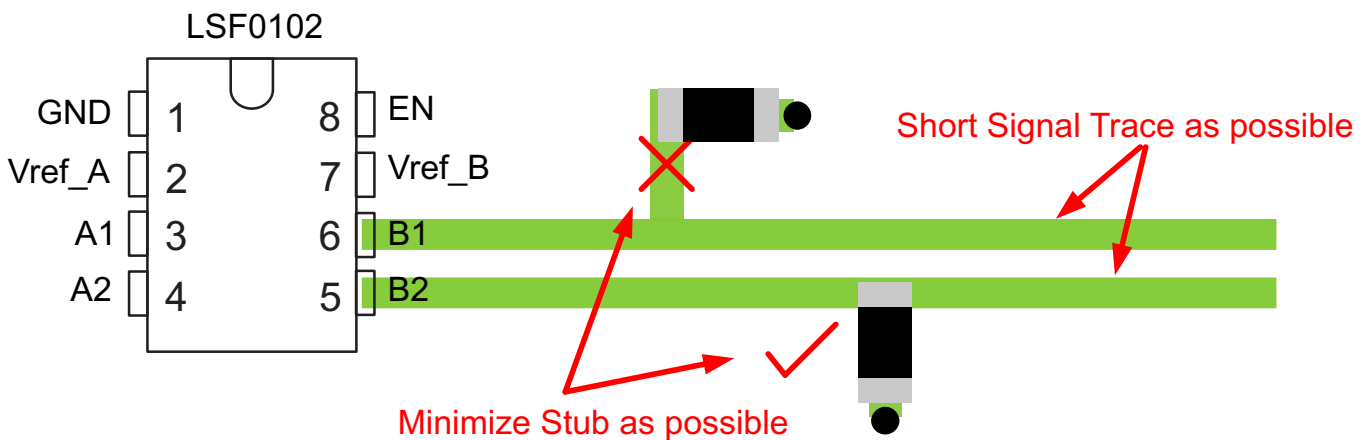

Figure 12. Short Trace Layout

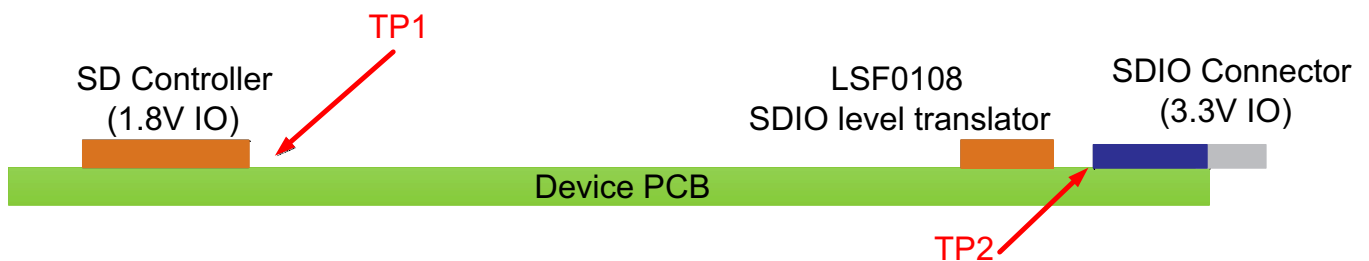
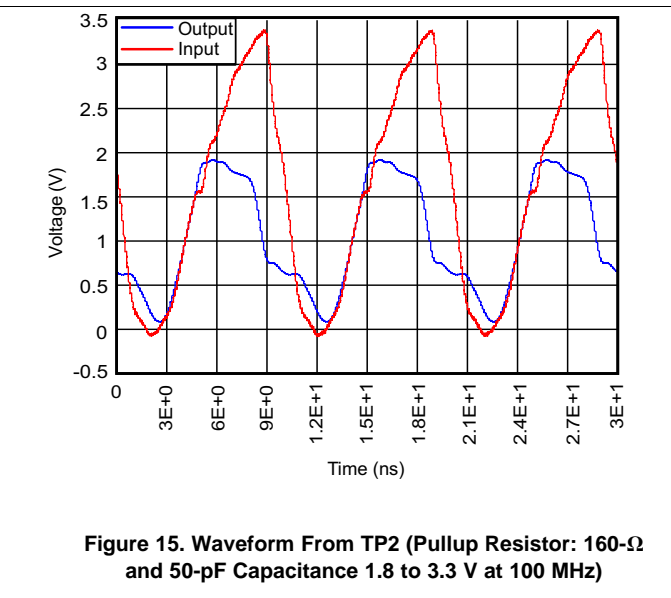
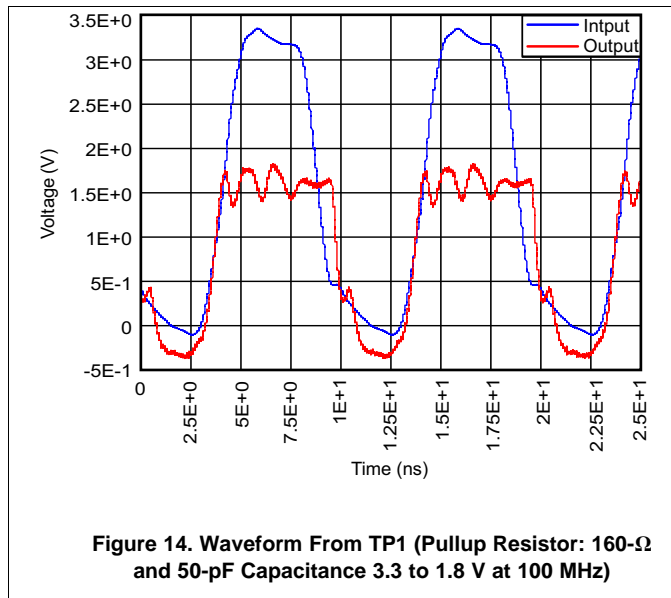

Figure 13. Device Placement

Layout Example (continued)



13 Device and Documentation Support

13.1 Related Links

The table below lists quick access links. Categories include technical documents, support and community resources, tools and software, and quick access to sample or buy.

Table 5. Related Links

PARTS	PRODUCT FOLDER	SAMPLE & BUY	TECHNICAL DOCUMENTS	TOOLS & SOFTWARE	SUPPORT & COMMUNITY
LSF0204	Click here	Click here	Click here	Click here	Click here
LSF0204D	Click here	Click here	Click here	Click here	Click here

13.2 Community Resources

The following links connect to TI community resources. Linked contents are provided "AS IS" by the respective contributors. They do not constitute TI specifications and do not necessarily reflect TI's views; see TI's [Terms of Use](#).

TI E2E™ Online Community *TI's Engineer-to-Engineer (E2E) Community*. Created to foster collaboration among engineers. At e2e.ti.com, you can ask questions, share knowledge, explore ideas and help solve problems with fellow engineers.

Design Support *TI's Design Support* Quickly find helpful E2E forums along with design support tools and contact information for technical support.

13.3 Trademarks

E2E is a trademark of Texas Instruments.
All other trademarks are the property of their respective owners.

13.4 Electrostatic Discharge Caution



These devices have limited built-in ESD protection. The leads should be shorted together or the device placed in conductive foam during storage or handling to prevent electrostatic damage to the MOS gates.

13.5 Glossary

SLYZ022 — *TI Glossary*.

This glossary lists and explains terms, acronyms, and definitions.

14 Mechanical, Packaging, and Orderable Information

The following pages include mechanical, packaging, and orderable information. This information is the most current data available for the designated devices. This data is subject to change without notice and revision of this document. For browser-based versions of this data sheet, refer to the left-hand navigation.

14.1 Package Option Addendum

14.1.1 Packaging Information

Orderable Device	Status ⁽¹⁾	Package Type	Package Drawing	Pins	Package Qty	Eco Plan ⁽²⁾	Lead/Ball Finish ⁽³⁾	MSL Peak Temp ⁽⁴⁾	Op Temp (°C)	Device Marking ⁽⁵⁾⁽⁶⁾
LSF0204DPWR	ACTIVE	TSSOP	PW	14	2000	Green (RoHS & no Sb/Br)	CU SN	Level-1-260C-UNLIM	-40 to 125	LSF204D
LSF0204DRGYR	ACTIVE	VQFN	RGY	14	3000	Green (RoHS & no Sb/Br)	CU NIPDAU	Level-2-260C-UNLIM	-40 to 125	LSF24D
LSF0204DRUTR	ACTIVE	UQFN	RUT	12	3000	Green (RoHS & no Sb/Br)	CU NIPDAU	Level-1-260C-UNLIM	-40 to 125	SIO
LSF0204DYZPR	ACTIVE	DSBGA	YZP	12	3000	Green (RoHS & no Sb/Br)	SNAGCU	Level-1-260C-UNLIM	-40 to 125	G6
LSF0204PWR	ACTIVE	TSSOP	PW	14	2000	Green (RoHS & no Sb/Br)	CU SN	Level-1-260C-UNLIM	-40 to 125	LSF204
LSF0204RGYR	ACTIVE	VQFN	RGY	14	3000	Green (RoHS & no Sb/Br)	CU NIPDAU	Level-2-260C-UNLIM	-40 to 125	LSF24
LSF0204RUTR	ACTIVE	UQFN	RUT	12	3000	Green (RoHS & no Sb/Br)	CU NIPDAU	Level-1-260C-UNLIM	-40 to 125	SIN
LSF0204YZPR	ACTIVE	DSBGA	YZP	12	3000	Green (RoHS & no Sb/Br)	SNAGCU	Level-1-260C-UNLIM	-40 to 125	G5

- (1) The marketing status values are defined as follows:
ACTIVE: Product device recommended for new designs.
LIFEBUY: TI has announced that the device will be discontinued, and a lifetime-buy period is in effect.
NRND: Not recommended for new designs. Device is in production to support existing customers, but TI does not recommend using this part in a new design.
PRE_PROD Unannounced device, not in production, not available for mass market, nor on the web, samples not available.
PREVIEW: Device has been announced but is not in production. Samples may or may not be available.
OBSOLETE: TI has discontinued the production of the device.
- (2) **RoHS:** TI defines "RoHS" to mean semiconductor products that are compliant with the current EU RoHS requirements for all 10 RoHS substances, including the requirement that RoHS substance do not exceed 0.1% by weight in homogeneous materials. Where designed to be soldered at high temperatures, "RoHS" products are suitable for use in specified lead-free processes. TI may reference these types of products as "Pb-Free".
RoHS Exempt: TI defines "RoHS Exempt" to mean products that contain lead but are compliant with EU RoHS pursuant to a specific EU RoHS exemption.
Green: TI defines "Green" to mean the content of Chlorine (Cl) and Bromine (Br) based flame retardants meet JS709B low halogen requirements of <=1000ppm threshold. Antimony trioxide based flame retardants must also meet the <=1000ppm threshold requirement
- (3) Lead/Ball Finish - Orderable Devices may have multiple material finish options. Finish options are separated by a vertical ruled line. Lead/Ball Finish values may wrap to two lines if the finish value exceeds the maximum column width.
- (4) MSL, Peak Temp. -- The Moisture Sensitivity Level rating according to the JEDEC industry standard classifications, and peak solder temperature.
- (5) There may be additional marking, which relates to the logo, the lot trace code information, or the environmental category on the device
- (6) Multiple Device markings will be inside parentheses. Only one Device Marking contained in parentheses and separated by a "-" will appear on a device. If a line is indented then it is a continuation of the previous line and the two combined represent the entire Device Marking for that device.

LSF0204, LSF0204D

SLVSCP5F –JULY 2014–REVISED JANUARY 2019

www.ti.com

Important Information and Disclaimer: The information provided on this page represents TI's knowledge and belief as of the date that it is provided. TI bases its knowledge and belief on information provided by third parties, and makes no representation or warranty as to the accuracy of such information. Efforts are underway to better integrate information from third parties. TI has taken and continues to take reasonable steps to provide representative and accurate information but may not have conducted destructive testing or chemical analysis on incoming materials and chemicals. TI and TI suppliers consider certain information to be proprietary, and thus CAS numbers and other limited information may not be available for release.

In no event shall TI's liability arising out of such information exceed the total purchase price of the TI part(s) at issue in this document sold by TI to Customer on an annual basis.

OTHER QUALIFIED VERSIONS OF LSF0204:

– Automotive: LSF0204-Q1

NOTE: Qualified Version Definitions:

Automotive - Q100 devices qualified for high-reliability automotive applications targeting zero defects

LSF0204/LSF0204D
YZP0012-C01

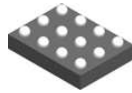

PACKAGE OUTLINE
DSBGA - 0.5 mm max height

DIE SIZE BALL GRID ARRAY

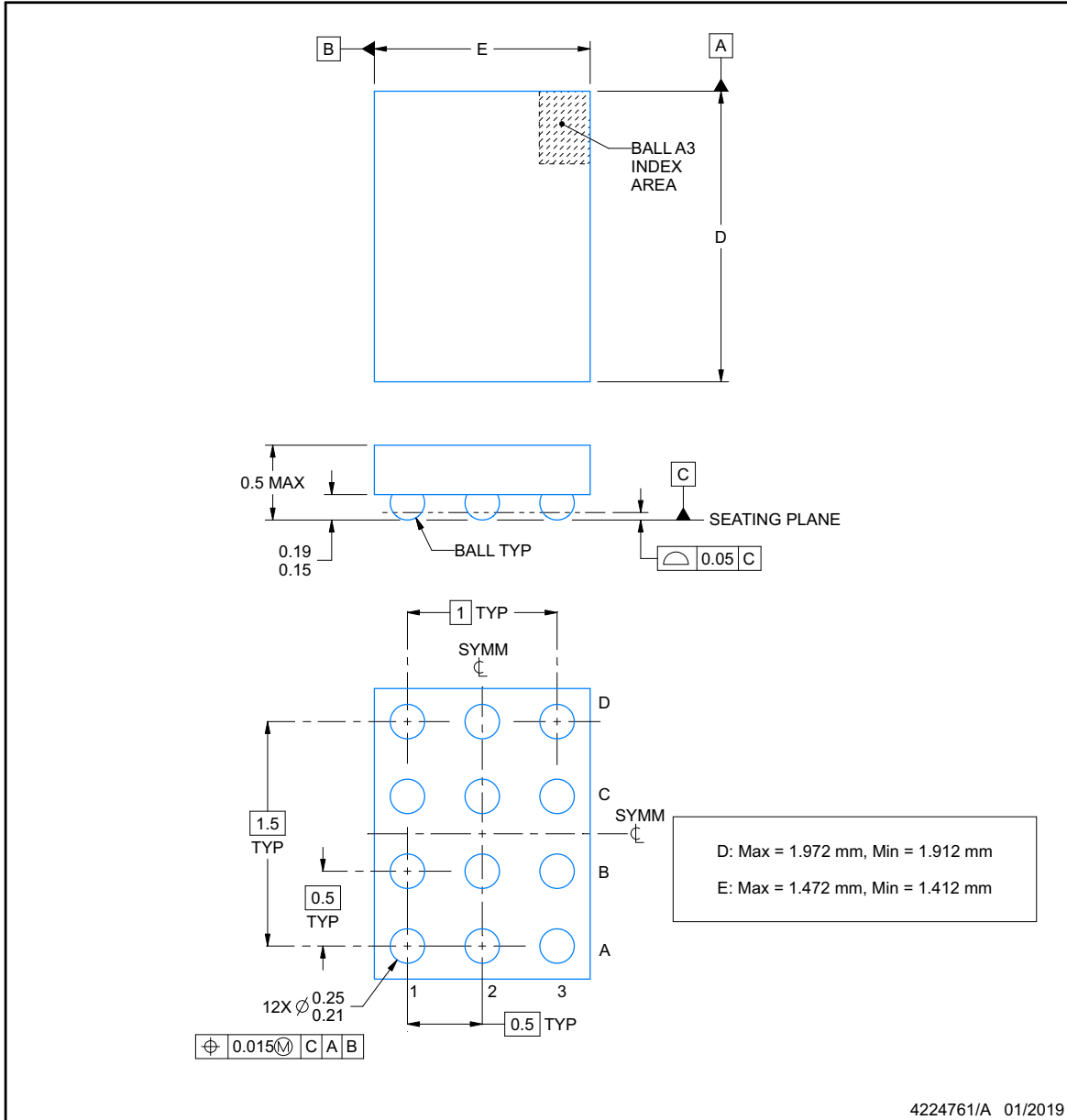

NOTES:

1. All linear dimensions are in millimeters. Any dimensions in parenthesis are for reference only. Dimensioning and tolerancing per ASME Y14.5M.
2. This drawing is subject to change without notice.

**LSF0204/LSF0204D
YZP0012-C01**

EXAMPLE BOARD LAYOUT

DSBGA - 0.5 mm max height

DIE SIZE BALL GRID ARRAY

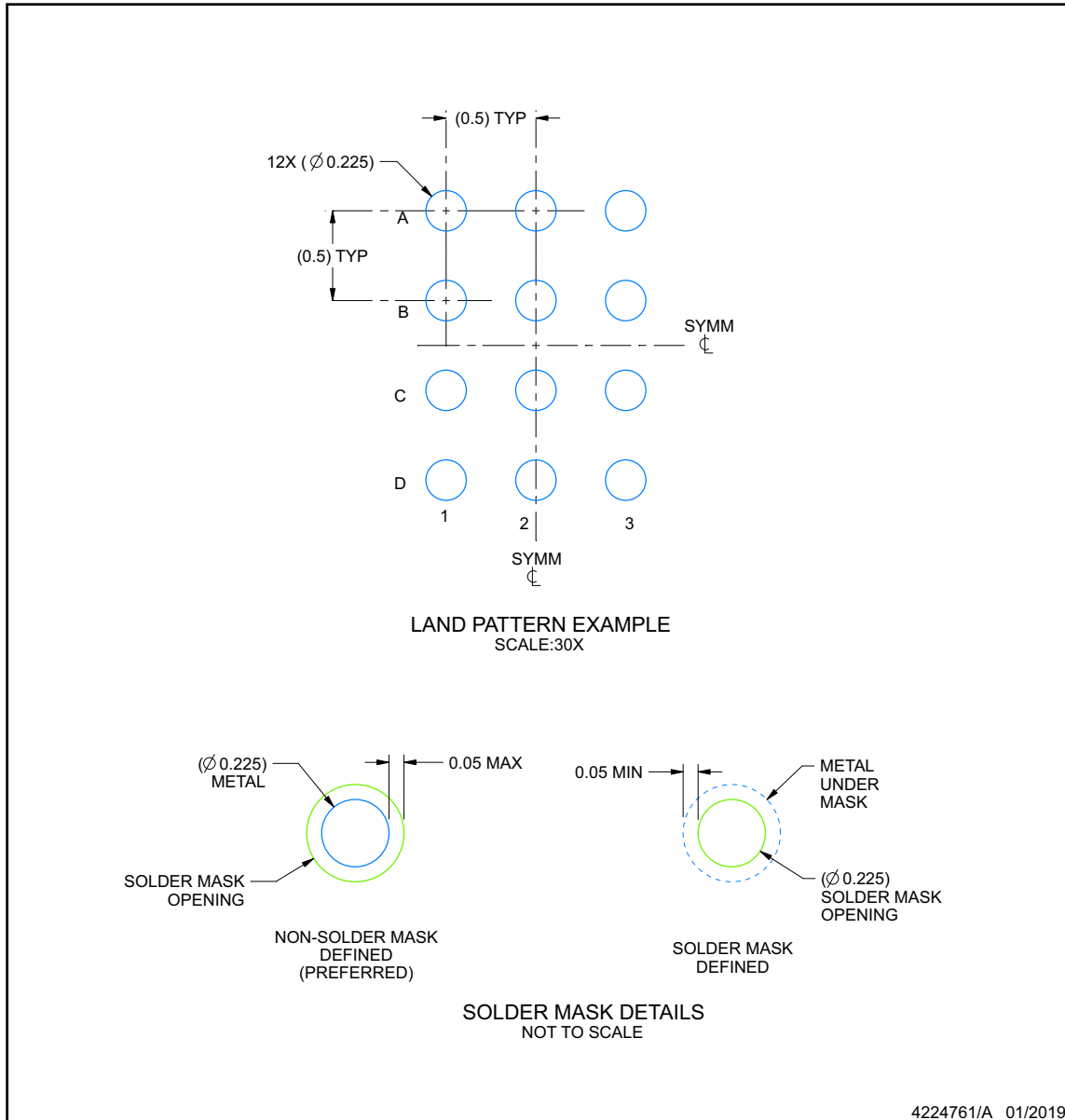

NOTES: (continued)

- 3. Final dimensions may vary due to manufacturing tolerance considerations and also routing constraints. For more information, see Texas Instruments literature number SBVA017 (www.ti.com/lit/sbva017).

**LSF0204/LSF0204D
YZP0012-C01**

EXAMPLE STENCIL DESIGN

DSBGA - 0.5 mm max height

DIE SIZE BALL GRID ARRAY

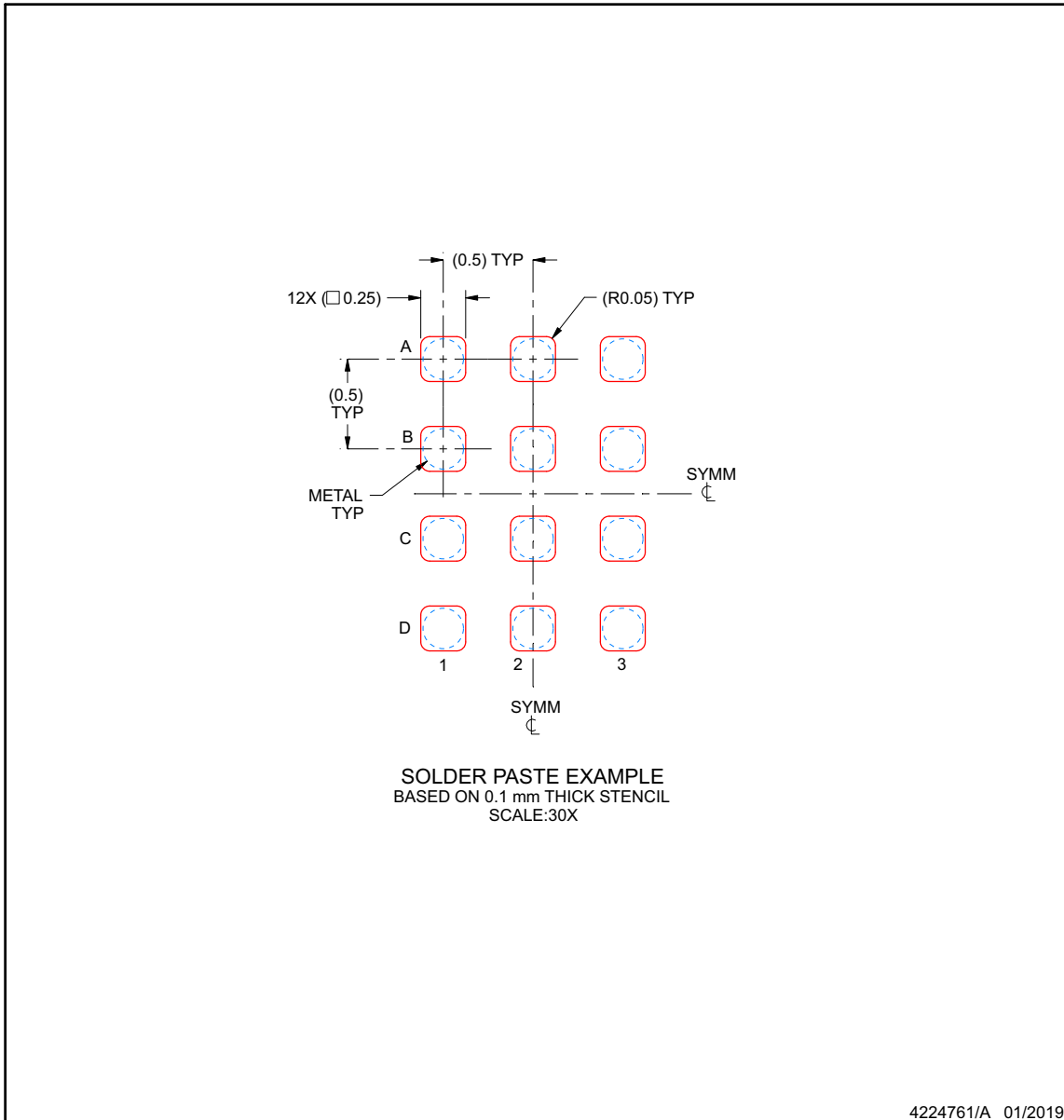

NOTES: (continued)

- 4. Laser cutting apertures with trapezoidal walls and rounded corners may offer better paste release.

TAPE AND REEL INFORMATION

QUADRANT ASSIGNMENTS FOR PIN 1 ORIENTATION IN TAPE

*All dimensions are nominal

Device	Package Type	Package Drawing	Pins	SPQ	Reel Diameter (mm)	Reel Width W1 (mm)	A0 (mm)	B0 (mm)	K0 (mm)	P1 (mm)	W (mm)	Pin1 Quadrant
LSF0204DPWR	TSSOP	PW	14	2000	330.0	12.4	6.9	5.6	1.6	8.0	12.0	Q1
LSF0204DRGYR	VQFN	RGY	14	3000	330.0	12.4	3.75	3.75	1.15	8.0	12.0	Q2
LSF0204DRUTR	UQFN	RUT	12	3000	180.0	9.5	1.9	2.3	0.75	4.0	8.0	Q1
LSF0204DYZPR	DSBGA	YZP	12	3000	180.0	8.4	1.63	2.08	0.69	4.0	8.0	Q2
LSF0204PWR	TSSOP	PW	14	2000	330.0	12.4	6.9	5.6	1.6	8.0	12.0	Q1
LSF0204RUTR	UQFN	RUT	12	3000	180.0	9.5	1.9	2.3	0.75	4.0	8.0	Q1
LSF0204YZPR	DSBGA	YZP	12	3000	180.0	8.4	1.63	2.08	0.69	4.0	8.0	Q2

TAPE AND REEL BOX DIMENSIONS

*All dimensions are nominal

Device	Package Type	Package Drawing	Pins	SPQ	Length (mm)	Width (mm)	Height (mm)
LSF0204DPWR	TSSOP	PW	14	2000	364.0	364.0	27.0
LSF0204DRGYR	VQFN	RGY	14	3000	367.0	367.0	35.0
LSF0204DRUTR	UQFN	RUT	12	3000	184.0	184.0	19.0
LSF0204DYZPR	DSBGA	YZP	12	3000	182.0	182.0	20.0
LSF0204PWR	TSSOP	PW	14	2000	364.0	364.0	27.0
LSF0204RUTR	UQFN	RUT	12	3000	184.0	184.0	19.0
LSF0204YZPR	DSBGA	YZP	12	3000	182.0	182.0	20.0

RGY (S-PVQFN-N14)

PLASTIC QUAD FLATPACK NO-LEAD

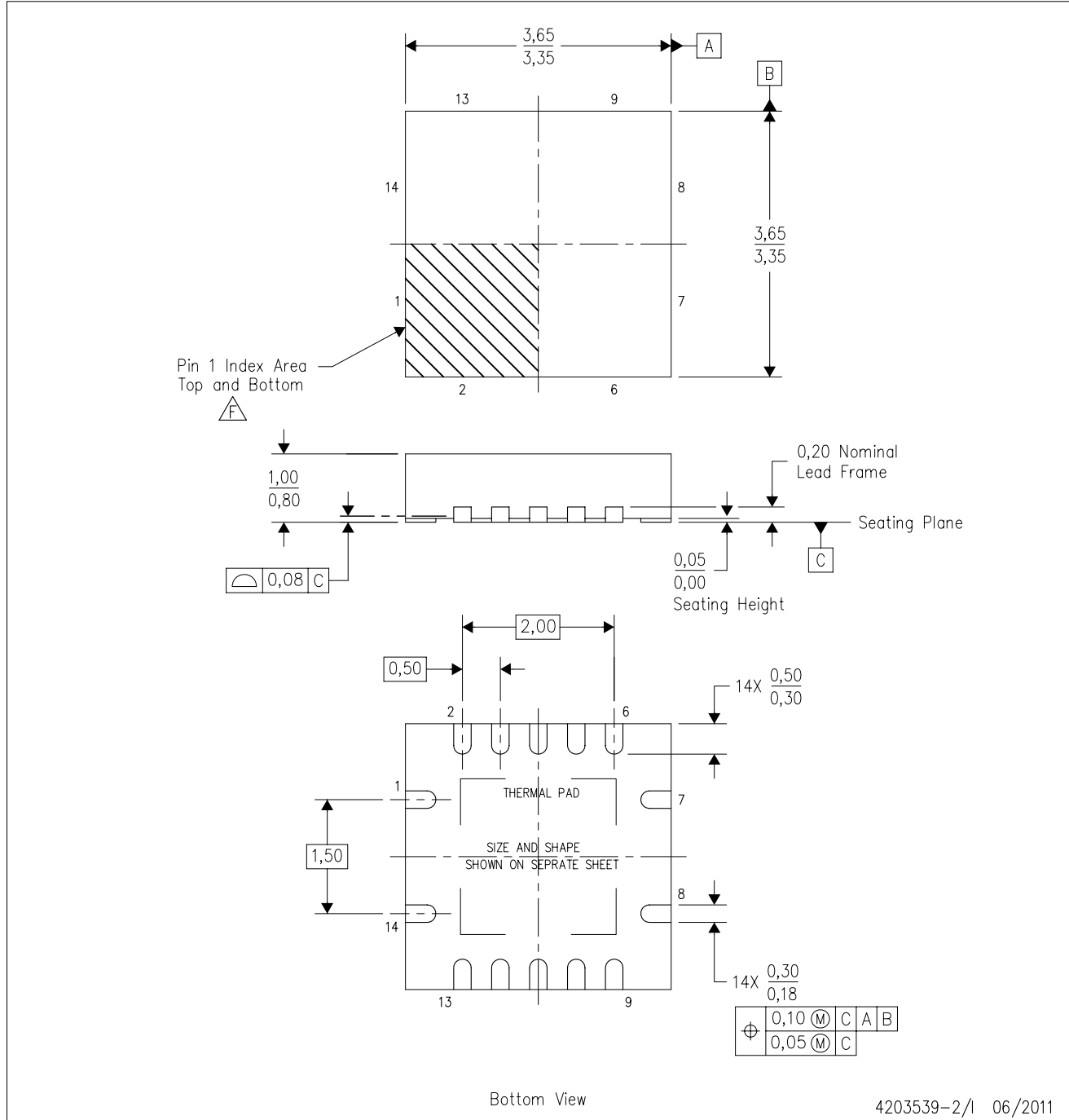

- NOTES:
- All linear dimensions are in millimeters. Dimensioning and tolerancing per ASME Y14.5M-1994.
 - This drawing is subject to change without notice.
 - QFN (Quad Flatpack No-Lead) package configuration.
 - The package thermal pad must be soldered to the board for thermal and mechanical performance.
 - See the additional figure in the Product Data Sheet for details regarding the exposed thermal pad features and dimensions.
 - Pin 1 identifiers are located on both top and bottom of the package and within the zone indicated. The Pin 1 identifiers are either a molded, marked, or metal feature.
 - Package complies to JEDEC MO-241 variation BA.

RGY (S-PVQFN-N14)

PLASTIC QUAD FLATPACK NO-LEAD

THERMAL INFORMATION

This package incorporates an exposed thermal pad that is designed to be attached directly to an external heatsink. The thermal pad must be soldered directly to the printed circuit board (PCB). After soldering, the PCB can be used as a heatsink. In addition, through the use of thermal vias, the thermal pad can be attached directly to the appropriate copper plane shown in the electrical schematic for the device, or alternatively, can be attached to a special heatsink structure designed into the PCB. This design optimizes the heat transfer from the integrated circuit (IC).

For information on the Quad Flatpack No-Lead (QFN) package and its advantages, refer to Application Report, QFN/SON PCB Attachment, Texas Instruments Literature No. SLUA271. This document is available at www.ti.com.

The exposed thermal pad dimensions for this package are shown in the following illustration.

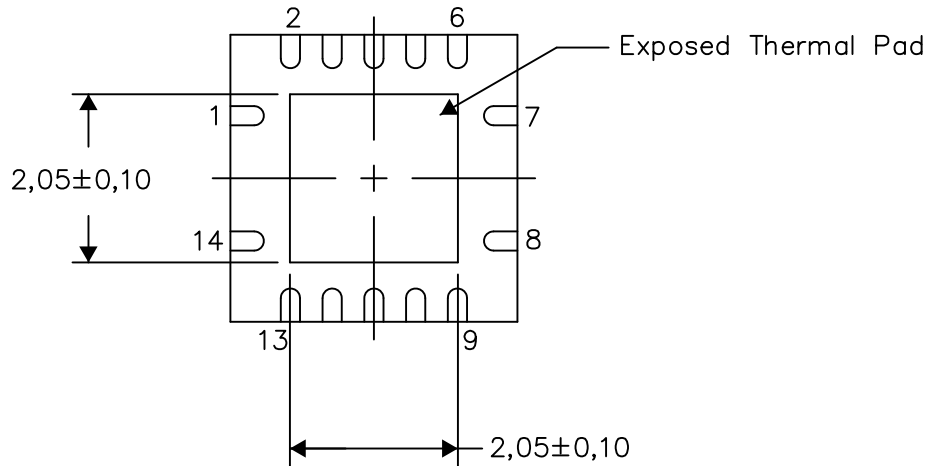

Bottom View

Exposed Thermal Pad Dimensions

4206353-2/P 03/14

NOTE: All linear dimensions are in millimeters

RGY (S-PVQFN-N14)

PLASTIC QUAD FLATPACK NO-LEAD

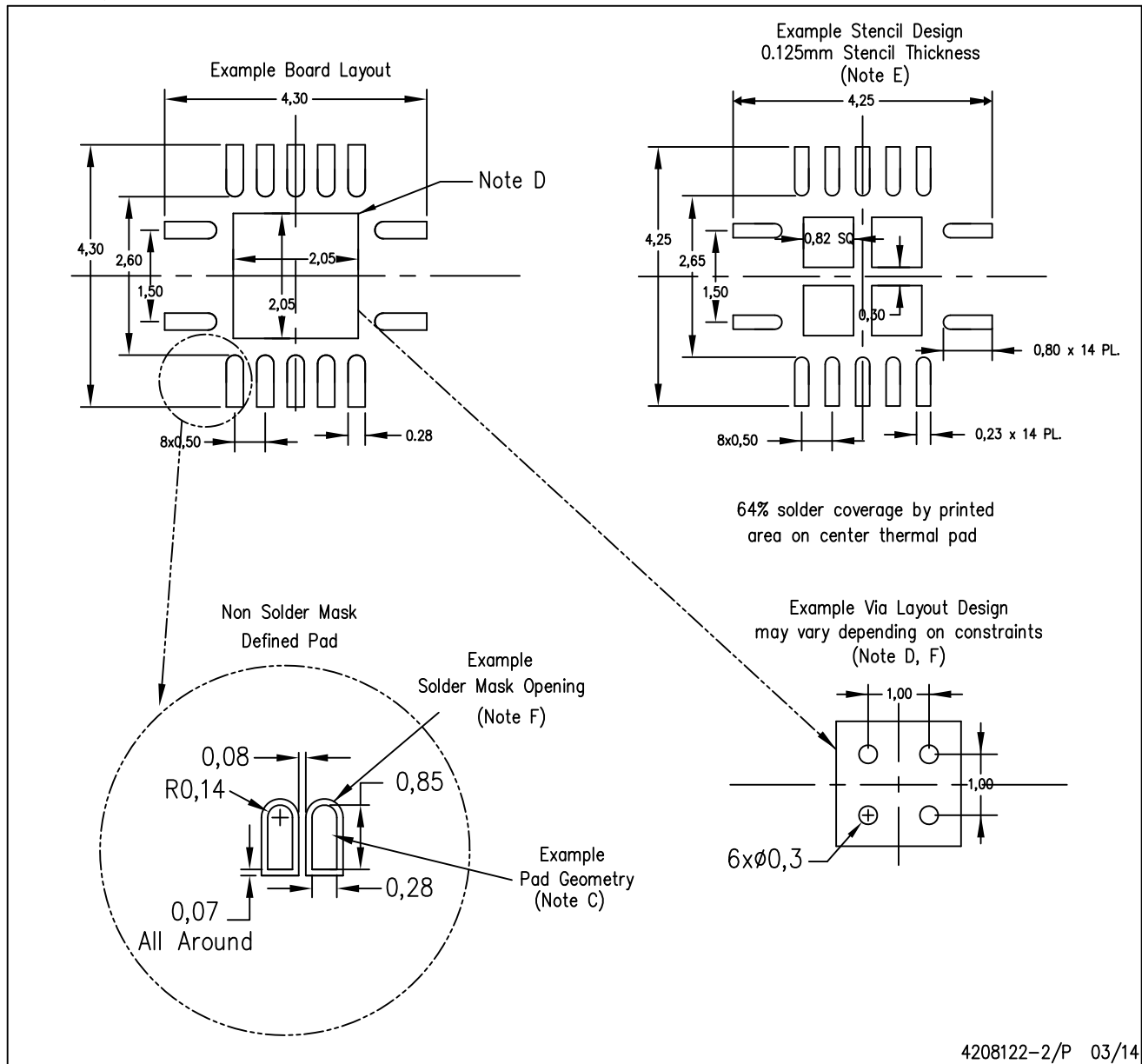

4208122-2/P 03/14

- NOTES:
- All linear dimensions are in millimeters.
 - This drawing is subject to change without notice.
 - Publication IPC-7351 is recommended for alternate designs.
 - This package is designed to be soldered to a thermal pad on the board. Refer to Application Note, Quad Flat-Pack QFN/SON PCB Attachment, Texas Instruments Literature No. SLUA271, and also the Product Data Sheets for specific thermal information, via requirements, and recommended board layout. These documents are available at www.ti.com <<http://www.ti.com>>.
 - Laser cutting apertures with trapezoidal walls and also rounding corners will offer better paste release. Customers should contact their board assembly site for stencil design recommendations. Refer to IPC 7525 for stencil design considerations.
 - Customers should contact their board fabrication site for minimum solder mask web tolerances between signal pads.

RUT (R-PUQFN-N12)

PLASTIC QUAD FLATPACK NO-LEAD

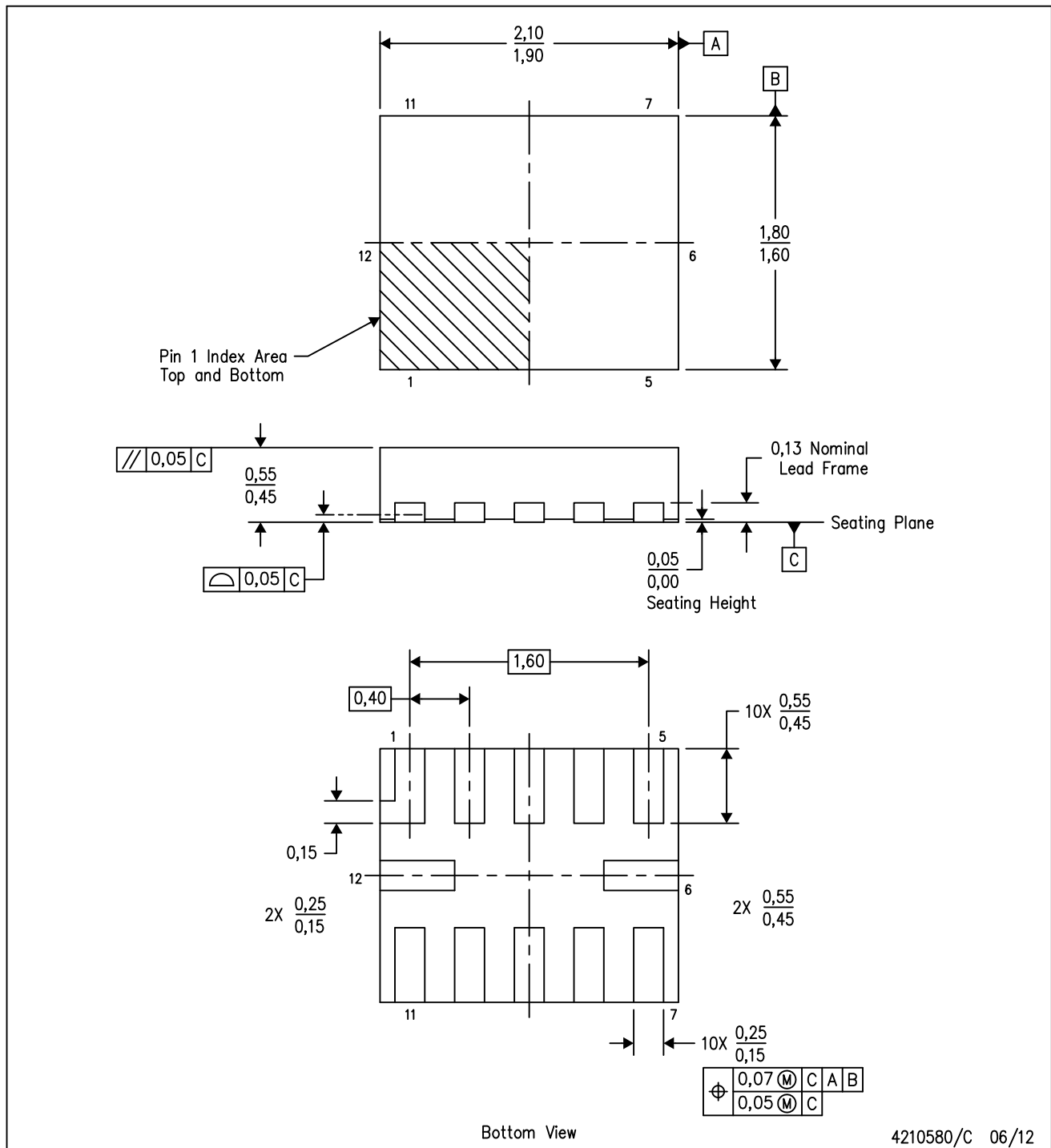

- NOTES:
- All linear dimensions are in millimeters. Dimensioning and tolerancing per ASME Y14.5M-1994.
 - This drawing is subject to change without notice.
 - QFN (Quad Flatpack No-Lead) package configuration.

RUT (R-PUQFN-N12)

PLASTIC QUAD FLATPACK NO-LEAD

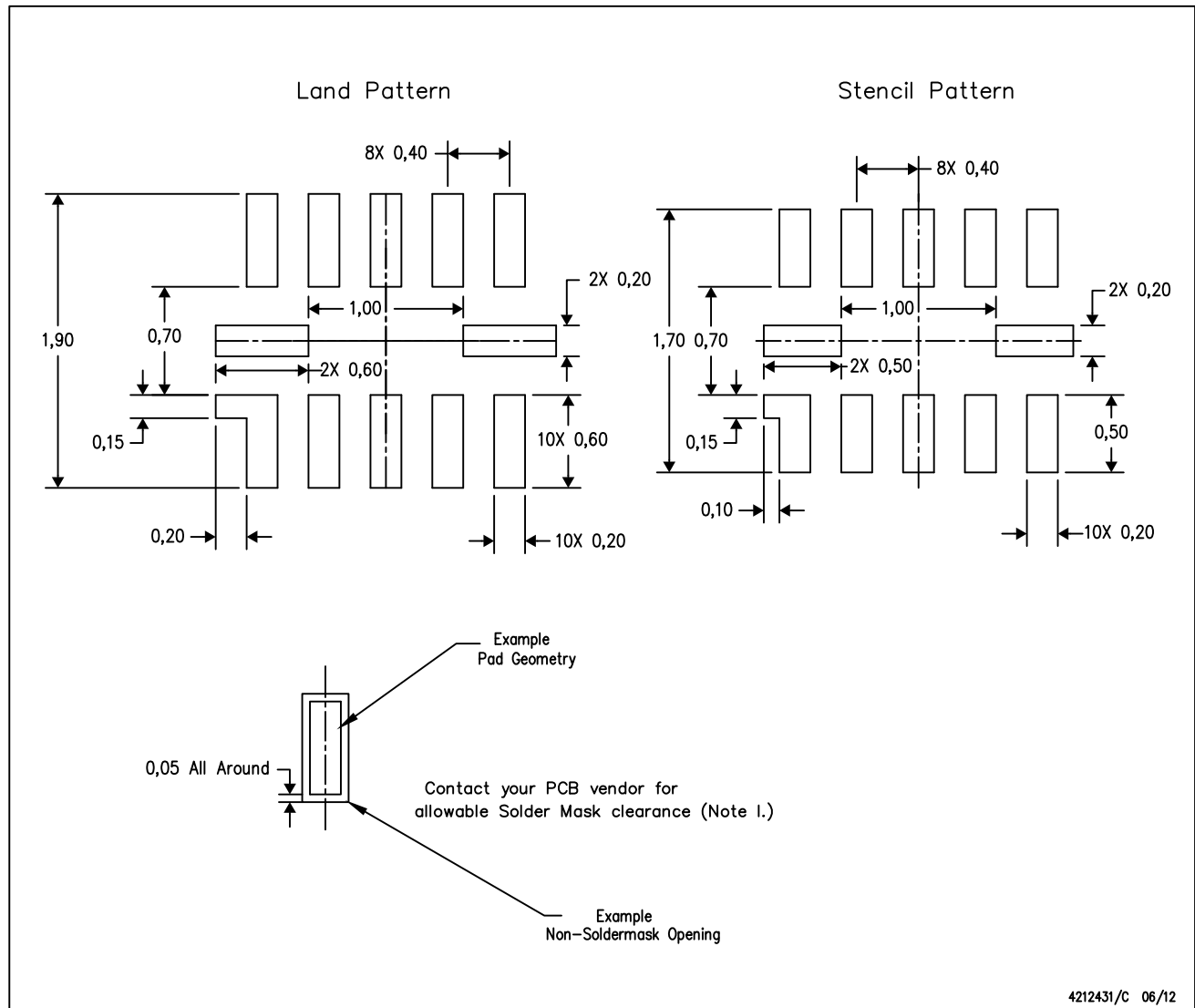

4212431/C 06/12

- NOTES:
- A. All linear dimensions are in millimeters.
 - B. This drawing is subject to change without notice.
 - C. Publication IPC-7351 is recommended for alternate designs.
 - D. Customers should contact their board fabrication site for minimum solder mask web tolerances between signal pads.
 - E. Maximum stencil thickness 0,1016 mm (4 mils). All linear dimensions are in millimeters.
 - F. Laser cutting apertures with trapezoidal walls and also rounding corners will offer better paste release. Customers should contact their board assembly site for stencil design recommendations. Refer to IPC 7525 for stencil design considerations.
 - G. Over-printing land for larger area ratio is not advised due to land width and bridging potential. Exercise extreme caution.
 - H. Suggest stencils cut with lasers such as Fiber Laser that produce the greatest positional accuracy.
 - I. Component placement force should be minimized to prevent excessive paste block deformation.

PW (R-PDSO-G14)

PLASTIC SMALL OUTLINE

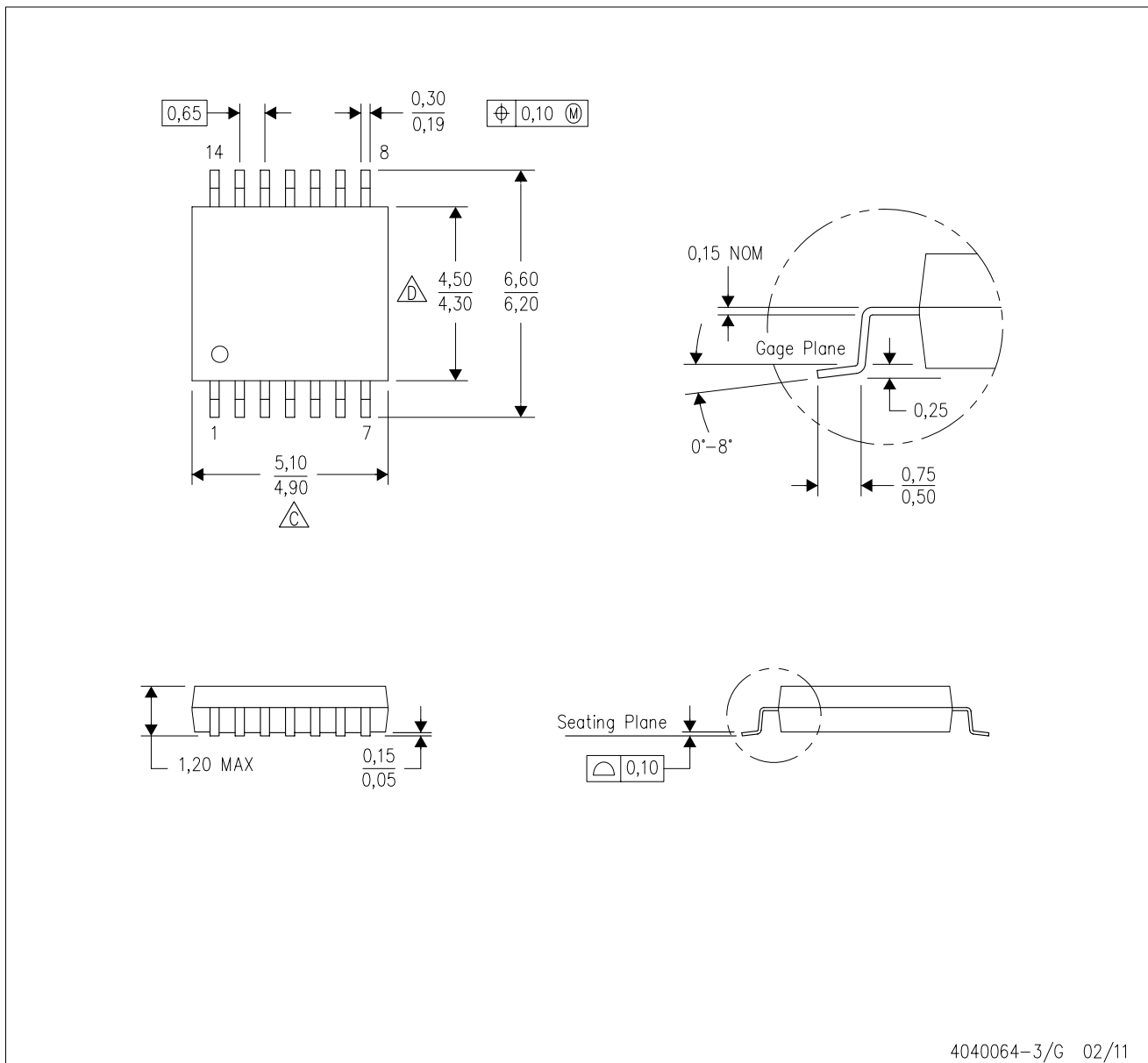

- NOTES:
- A. All linear dimensions are in millimeters. Dimensioning and tolerancing per ASME Y14.5M-1994.
 - B. This drawing is subject to change without notice.
 - C. Body length does not include mold flash, protrusions, or gate burrs. Mold flash, protrusions, or gate burrs shall not exceed 0,15 each side.
 - D. Body width does not include interlead flash. Interlead flash shall not exceed 0,25 each side.
 - E. Falls within JEDEC MO-153

PW (R-PDSO-G14)

PLASTIC SMALL OUTLINE



- NOTES:
- All linear dimensions are in millimeters.
 - This drawing is subject to change without notice.
 - Publication IPC-7351 is recommended for alternate designs.
 - Laser cutting apertures with trapezoidal walls and also rounding corners will offer better paste release. Customers should contact their board assembly site for stencil design recommendations. Refer to IPC-7525 for other stencil recommendations.
 - Customers should contact their board fabrication site for solder mask tolerances between and around signal pads.

IMPORTANT NOTICE AND DISCLAIMER

TI PROVIDES TECHNICAL AND RELIABILITY DATA (INCLUDING DATASHEETS), DESIGN RESOURCES (INCLUDING REFERENCE DESIGNS), APPLICATION OR OTHER DESIGN ADVICE, WEB TOOLS, SAFETY INFORMATION, AND OTHER RESOURCES "AS IS" AND WITH ALL FAULTS, AND DISCLAIMS ALL WARRANTIES, EXPRESS AND IMPLIED, INCLUDING WITHOUT LIMITATION ANY IMPLIED WARRANTIES OF MERCHANTABILITY, FITNESS FOR A PARTICULAR PURPOSE OR NON-INFRINGEMENT OF THIRD PARTY INTELLECTUAL PROPERTY RIGHTS.

These resources are intended for skilled developers designing with TI products. You are solely responsible for (1) selecting the appropriate TI products for your application, (2) designing, validating and testing your application, and (3) ensuring your application meets applicable standards, and any other safety, security, or other requirements. These resources are subject to change without notice. TI grants you permission to use these resources only for development of an application that uses the TI products described in the resource. Other reproduction and display of these resources is prohibited. No license is granted to any other TI intellectual property right or to any third party intellectual property right. TI disclaims responsibility for, and you will fully indemnify TI and its representatives against, any claims, damages, costs, losses, and liabilities arising out of your use of these resources.

TI's products are provided subject to TI's Terms of Sale (www.ti.com/legal/termsofsale.html) or other applicable terms available either on ti.com or provided in conjunction with such TI products. TI's provision of these resources does not expand or otherwise alter TI's applicable warranties or warranty disclaimers for TI products.

Mailing Address: Texas Instruments, Post Office Box 655303, Dallas, Texas 75265
Copyright © 2019, Texas Instruments Incorporated

Looking for pricing, stock, or lifecycle information?

Click below to explore more details on WIN SOURCE:

 [View LSF0204DPWR](#) on WIN SOURCE

 [Texas Instruments](#) Information

Optimize Your Supply Chain with WIN SOURCE Solutions

-  Global Sourcing Solution
-  Obsolete Management
-  Cost Control Management
-  Shortage Management
-  Alternative Solution
-  Excess Inventory Management