



**THE DATASHEET OF
CY7C1011DV33-10BVI**



2-Mbit (128 K × 16) Static RAM

Features

- Pin-and function-compatible with CY7C1011CV33
- High speed
 - $t_{AA} = 10 \text{ ns}$
- Low active power
 - $I_{CC} = 90 \text{ mA @ } 10 \text{ ns (Industrial)}$
- Low CMOS standby power
 - $I_{SB2} = 10 \text{ mA}$
- Data Retention at 2.0 V
- Automatic power-down when deselected
- Independent control of upper and lower bits
- Easy memory expansion with \overline{CE} and \overline{OE} features
- Available in Pb-free 44-pin TSOP II, and 48-ball VFBGA

Functional Description

The CY7C1011DV33^[1] is a high-performance CMOS Static RAM organized as 128 K words by 16 bits.

Writing to the device is accomplished by taking Chip Enable (\overline{CE}) and Write Enable (\overline{WE}) inputs LOW. If Byte Low Enable (\overline{BLE}) is LOW, then data from I/O pins (I/O₀ through I/O₇), is written into the location specified on the address pins (A₀ through A₁₆). If Byte High Enable (\overline{BHE}) is LOW, then data from I/O pins (I/O₈ through I/O₁₅) is written into the location specified on the address pins (A₀ through A₁₆).

Reading from the device is accomplished by taking Chip Enable (\overline{CE}) and Output Enable (\overline{OE}) LOW while forcing the Write Enable (\overline{WE}) HIGH. If Byte Low Enable (\overline{BLE}) is LOW, then data from the memory location specified by the address pins will appear on I/O₀ to I/O₇. If Byte High Enable (\overline{BHE}) is LOW, then data from memory will appear on I/O₈ to I/O₁₅. See the truth table at the back of this data sheet for a complete description of read and write modes.

The input/output pins (I/O₀ through I/O₁₅) are placed in a high-impedance state when the device is deselected (\overline{CE} HIGH), the outputs are disabled (\overline{OE} HIGH), the \overline{BHE} and \overline{BLE} are disabled (\overline{BHE} , \overline{BLE} HIGH), or during a write operation (\overline{CE} LOW, and \overline{WE} LOW).

The CY7C1011DV33 is available in standard Pb-free 44-pin TSOP II with center power and ground pinout, as well as 48-ball very fine-pitch ball grid array (VFBGA) packages.

For a complete list of related resources, [click here](#).

Logic Block Diagram

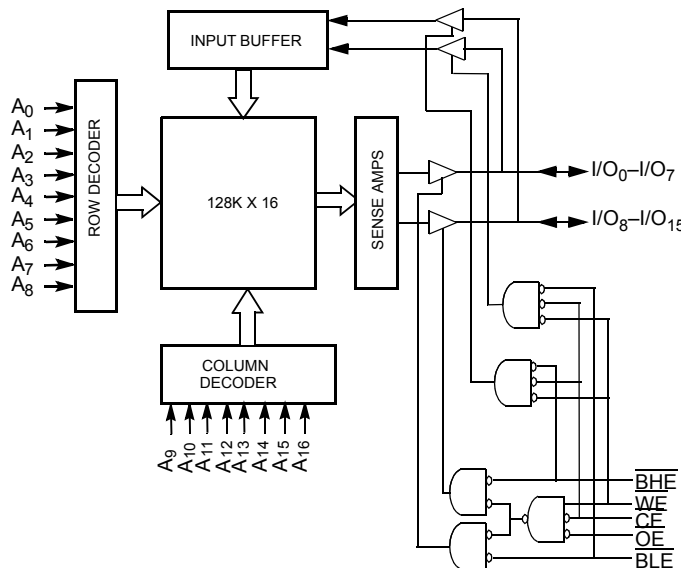

Note

1. For guidelines on SRAM system design, please refer to the "System Design Guidelines" Cypress application note, available on the internet at www.cypress.com

Contents

Selection Guide	3	Ordering Information	12
Pin Configurations	3	Ordering Code Definitions	12
Maximum Ratings	4	Package Diagrams	13
Operating Range	4	Acronyms	14
DC Electrical Characteristics	4	Document Conventions	14
Capacitance	5	Units of Measure	14
Thermal Resistance	5	Document History	15
AC Test Loads and Waveforms	5	Sales, Solutions, and Legal Information	17
Data Retention Characteristics	6	Worldwide Sales and Design Support	17
Data Retention Waveform	6	Products	17
AC Switching Characteristics	7	PSoC® Solutions	17
Switching Waveforms	8	Cypress Developer Community	17
Truth Table	11	Technical Support	17

Selection Guide

Description	-10	Unit
Maximum Access Time	10	ns
Maximum Operating Current	90	mA
Maximum CMOS Standby Current	10	mA

Pin Configurations

Figure 1. 44-pin TSOP II pinout (Top View)

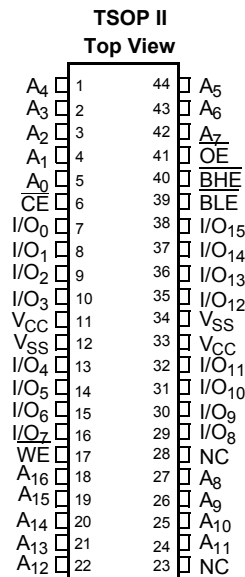
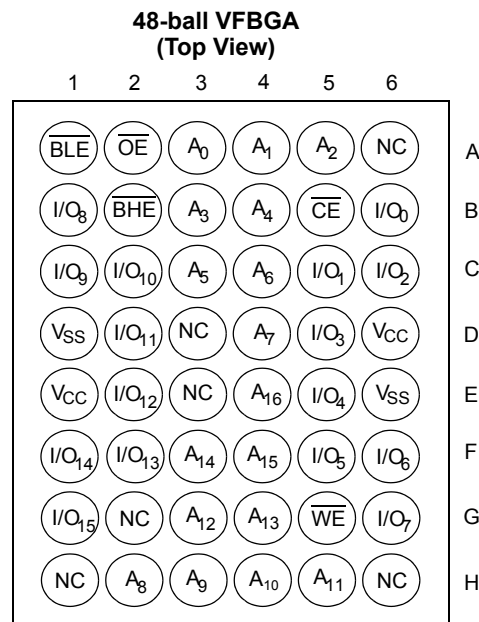

Figure 2. 48-ball VFBGA pinout (Top View)



Maximum Ratings

Exceeding maximum ratings may shorten the useful life of the device. User guidelines are not tested.

Storage temperature -65 °C to +150 °C

Ambient temperature with power applied -55 °C to +125 °C

Supply voltage on V_{CC} to relative GND ^[2] -0.3 V to +4.6 V

DC voltage applied to outputs in high Z State ^[2] -0.3 V to $V_{CC} + 0.3$ V

DC input voltage ^[2] -0.3 V to $V_{CC} + 0.3$ V

Current into outputs (LOW) 20 mA

Static discharge voltage (per MIL-STD-883, method 3015) > 2001 V

Latch-up current > 200 mA

Operating Range

Range	Ambient Temperature	V_{CC}
Industrial	-40 °C to +85 °C	3.3 V ± 0.3 V

DC Electrical Characteristics

Over the Operating Range

Parameter	Description	Test Conditions	-10		Unit	
			Min	Max		
V_{OH}	Output HIGH voltage	$V_{CC} = \text{Min}, I_{OH} = -4.0 \text{ mA}$	2.4	-	V	
V_{OL}	Output LOW voltage	$V_{CC} = \text{Min}, I_{OL} = 8.0 \text{ mA}$	-	0.4	V	
V_{IH}	Input HIGH voltage		2.0	$V_{CC} + 0.3$	V	
V_{IL}	Input LOW voltage ^[3]		-0.3	0.8	V	
I_{IX}	Input leakage current	$GND \leq V_I \leq V_{CC}$	-1	+1	μA	
I_{OZ}	Output leakage current	$GND \leq V_{OUT} \leq V_{CC}$, Output Disabled	-1	+1	μA	
I_{CC}	V_{CC} operating supply current	$V_{CC} = \text{Max}, f = f_{MAX} = 1/t_{RC}$	100 MHz	-	90	mA
			83 MHz	-	80	
			66 MHz	-	70	
			40 MHz	-	60	
I_{SB1}	Automatic CE Power-down Current — TTL Inputs	$\text{Max } V_{CC}, \overline{CE} \geq V_{IH}, V_{IN} \geq V_{IH} \text{ or } V_{IN} \leq V_{IL}, f = f_{MAX}$	-	20	mA	
I_{SB2}	Automatic CE Power-down Current — CMOS Inputs	$\text{Max } V_{CC}, \overline{CE} \geq V_{CC} - 0.3 \text{ V}, V_{IN} \geq V_{CC} - 0.3 \text{ V}, \text{ or } V_{IN} \leq 0.3 \text{ V}, f = 0$	-	10	mA	

Notes

2. Tested initially and after any design or process changes that may affect these parameters.
3. $V_{IL}(\text{min}) = -2.0 \text{ V}$ and $V_{IH}(\text{max}) = V_{CC} + 2 \text{ V}$ for pulse durations of less than 20 ns.

Capacitance

Parameter ^[4]	Description	Test Conditions	Max	Unit
C _{IN}	Input capacitance	T _A = 25 °C, f = 1 MHz, V _{CC} = 3.3 V	8	pF
C _{OUT}	I/O capacitance		8	pF

Thermal Resistance

Parameter ^[4]	Description	Test Conditions	TSOP II	VFBGA	Unit
Θ _{JA}	Thermal resistance (junction to ambient)	Still air, soldered on a 3 × 4.5 inch, four-layer printed circuit board	50.66	27.89	°C/W
Θ _{JC}	Thermal resistance (junction to case)		17.17	14.74	°C/W

AC Test Loads and Waveforms

Figure 3. AC Test Loads and Waveforms ^[5]

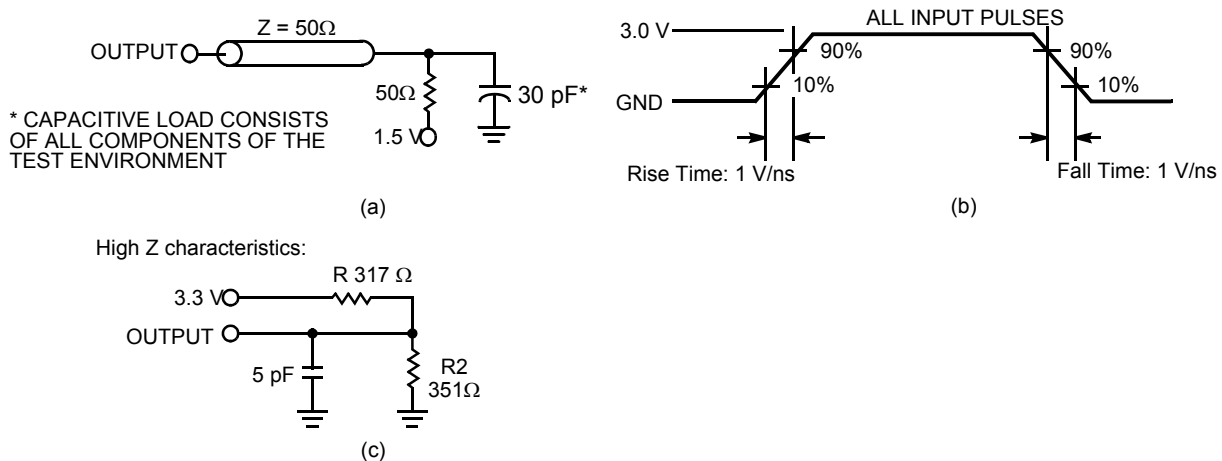

Note

- 4. Tested initially and after any design or process changes that may affect these parameters.
- 5. AC characteristics (except high Z) are tested using the load conditions shown in (a). High Z characteristics are tested for all speeds using the test load shown in (c).

Data Retention Characteristics

Over the Operating Range

Parameter	Description	Conditions ^[6]	Min	Max	Unit
V_{DR}	V_{CC} for data retention		2.0	–	V
I_{CCDR}	Data retention current		–	10	mA
$t_{CDR}^{[7]}$	Chip deselect to data retention time	$V_{CC} = V_{DR} = 2.0\text{ V}$, $\overline{CE} \geq V_{CC} - 0.3\text{ V}$, $V_{IN} \geq V_{CC} - 0.3\text{ V}$ or $V_{IN} \leq 0.3\text{ V}$	0	–	ns
$t_R^{[8]}$	Operation recovery time		t_{RC}	–	ns

Data Retention Waveform

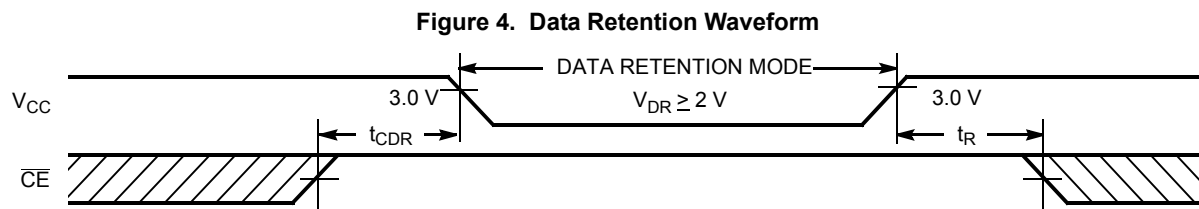

Notes

6. No input may exceed $V_{CC} + 0.3\text{ V}$.
7. Tested initially and after any design or process changes that may affect these parameters.
8. Full device operation requires linear V_{CC} ramp from V_{DR} to $V_{CC(\text{min.})} \geq 50\ \mu\text{s}$ or stable at $V_{CC(\text{min.})} \geq 50\ \mu\text{s}$.

AC Switching Characteristics

Over the Operating Range

Parameter ^[9]	Description	-10		Unit
		Min	Max	
Read Cycle				
$t_{power}^{[10]}$	V_{CC} (typical) to the first access	100	–	μ s
t_{RC}	Read cycle time	10	–	ns
t_{AA}	Address to data valid	–	10	ns
t_{OHA}	Data hold from address change	3	–	ns
t_{ACE}	\overline{CE} LOW to data valid	–	10	ns
t_{DOE}	\overline{OE} LOW to data valid	–	5	ns
t_{LZOE}	\overline{OE} LOW to low Z ^[11]	0	–	ns
t_{HZOE}	\overline{OE} HIGH to high Z ^[11, 12]	–	5	ns
t_{LZCE}	\overline{CE} LOW to low Z ^[11]	3	–	ns
t_{HZCE}	\overline{CE} HIGH to high Z ^[11, 12]	–	5	ns
t_{PU}	\overline{CE} LOW to power-up	0	–	ns
t_{PD}	\overline{CE} HIGH to power-down	–	10	ns
t_{DBE}	Byte enable to data valid	–	5	ns
t_{LZBE}	Byte enable to low Z	0	–	ns
t_{HZBE}	Byte disable to high Z	–	6	ns
Write Cycle ^[13, 14]				
t_{WC}	Write cycle time	10	–	ns
t_{SCE}	\overline{CE} LOW to write end	7	–	ns
t_{AW}	Address set-up to write end	7	–	ns
t_{HA}	Address hold from write end	0	–	ns
t_{SA}	Address set-up to write start	0	–	ns
t_{PWE}	\overline{WE} pulse width	7	–	ns
t_{SD}	Data set-up to write end	5	–	ns
t_{HD}	Data hold from write end	0	–	ns
t_{LZWE}	\overline{WE} HIGH to low Z ^[11]	3	–	ns
t_{HZWE}	\overline{WE} LOW to high Z ^[11, 12]	–	5	ns
t_{BW}	Byte enable to end of write	7	–	ns

Notes

9. Test conditions assume signal transition time of 3 ns or less, timing reference levels of 1.5 V, input pulse levels of 0 to 3.0 V.
10. t_{POWER} gives the minimum amount of time that the power supply should be at typical V_{CC} values until the first memory access is performed.
11. At any given temperature and voltage condition, t_{HZCE} is less than t_{LZCE} , t_{HZOE} is less than t_{LZOE} , t_{HZBE} is less than t_{LZBE} , and t_{HZWE} is less than t_{LZWE} for any given device.
12. t_{HZOE} , t_{HZCE} , t_{HZBE} and t_{HZWE} are specified with a load capacitance of 5 pF as in part (d) of AC Test Loads. Transition is measured when the outputs enter a high impedance state.
13. The internal write time of the memory is defined by the overlap of \overline{CE} LOW, and \overline{WE} LOW. \overline{CE} and \overline{WE} must be LOW to initiate a write, and the transition of either of these signals can terminate the write. The input data set-up and hold timing should be referenced to the leading edge of the signal that terminates the write.
14. The minimum write cycle pulse width for Write Cycle No. 4 (\overline{WE} Controlled, \overline{OE} LOW) should be the sum of t_{SD} and t_{HZWE} .

Switching Waveforms

Figure 5. Read Cycle No. 1 [15, 16]

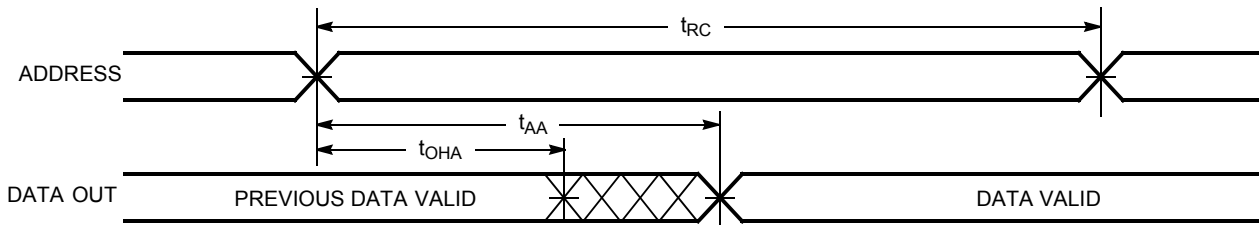
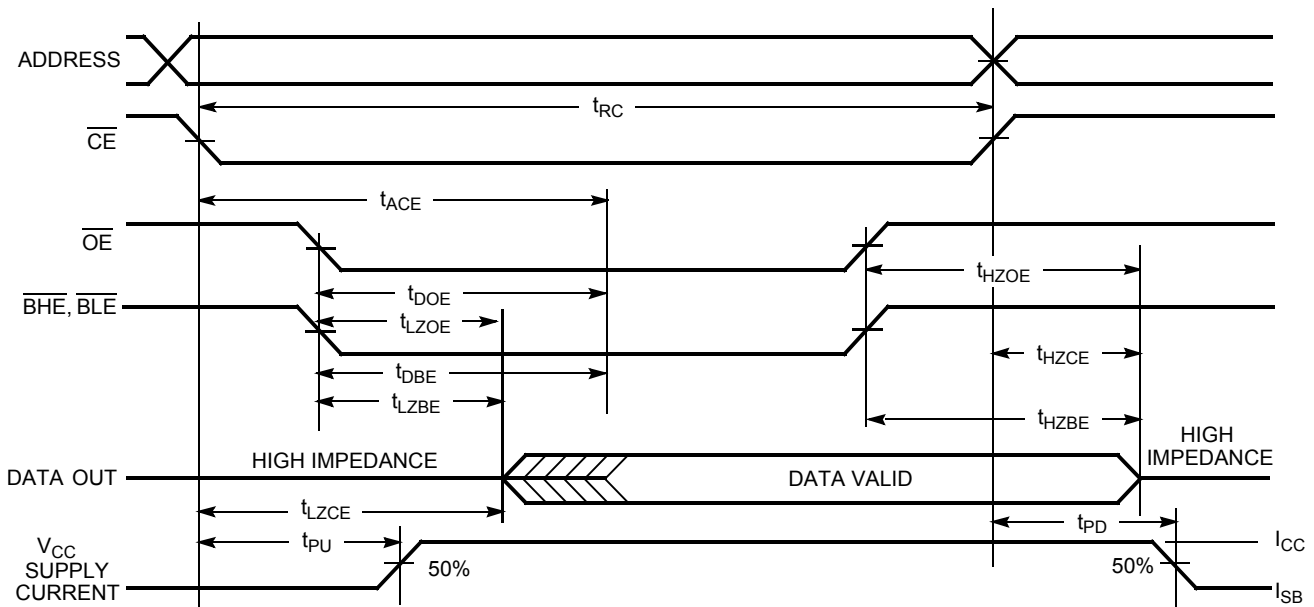

Figure 6. Read Cycle No. 2 (\overline{OE} Controlled) [16, 17]



Notes

- 15. Device is continuously selected. \overline{OE} , \overline{CE} , \overline{BHE} and/or \overline{BLE} = V_{IL} .
- 16. \overline{WE} is HIGH for read cycle.
- 17. Address valid prior to or coincident with \overline{CE} transition LOW.

Switching Waveforms (continued)

Figure 7. Write Cycle No. 1 ($\overline{\text{CE}}$ Controlled) [18, 19]

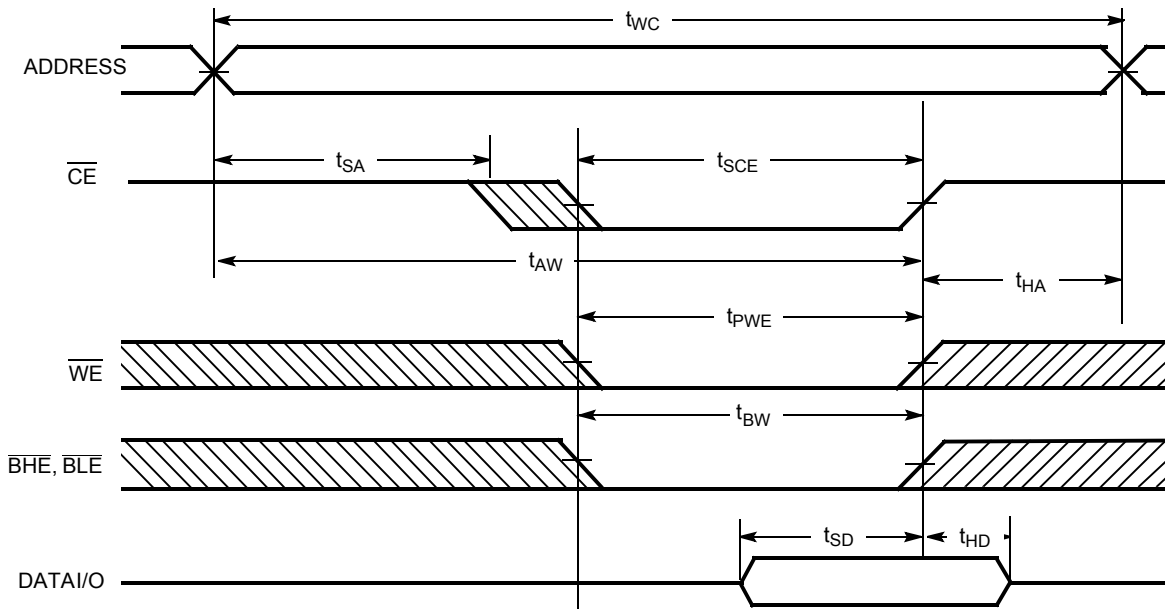
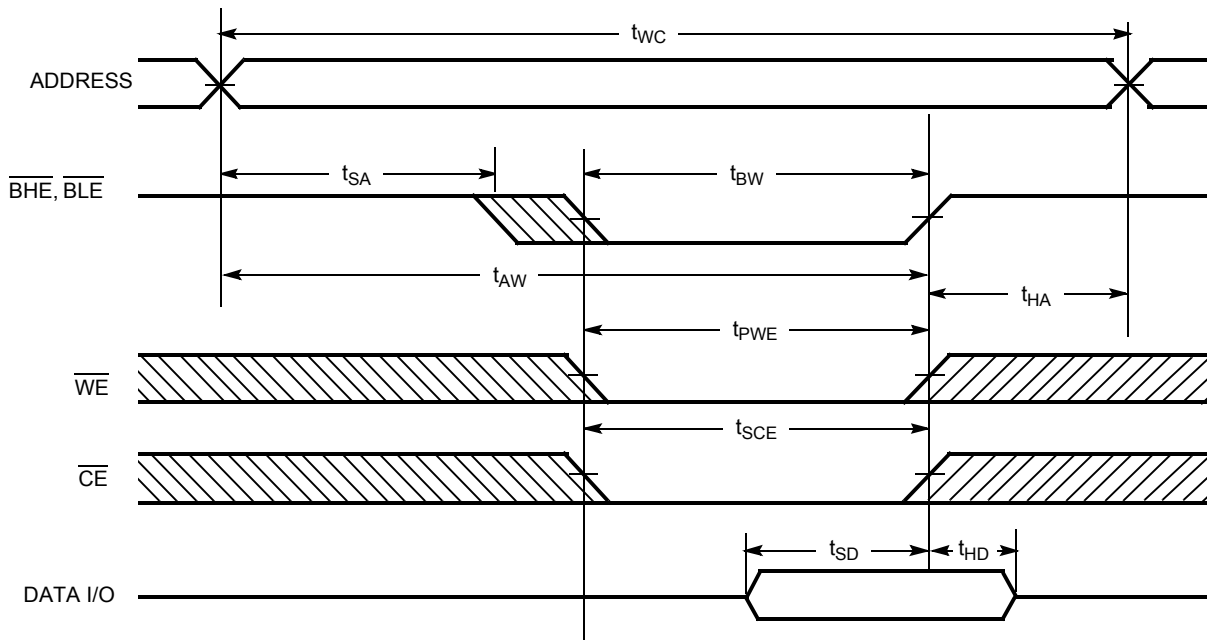

Figure 8. Write Cycle No. 2 ($\overline{\text{BLE}}$ or $\overline{\text{BHE}}$ Controlled)



Notes

- 18. Data I/O is high-impedance if $\overline{\text{OE}}$ or $\overline{\text{BHE}}$ and/or $\overline{\text{BLE}} = V_{IH}$.
- 19. If $\overline{\text{CE}}$ goes HIGH simultaneously with $\overline{\text{WE}}$ going HIGH, the output remains in a high-impedance state.

Switching Waveforms (continued)

Figure 9. Write Cycle No. 3 (\overline{WE} Controlled, \overline{OE} HIGH During Write) [20, 21]

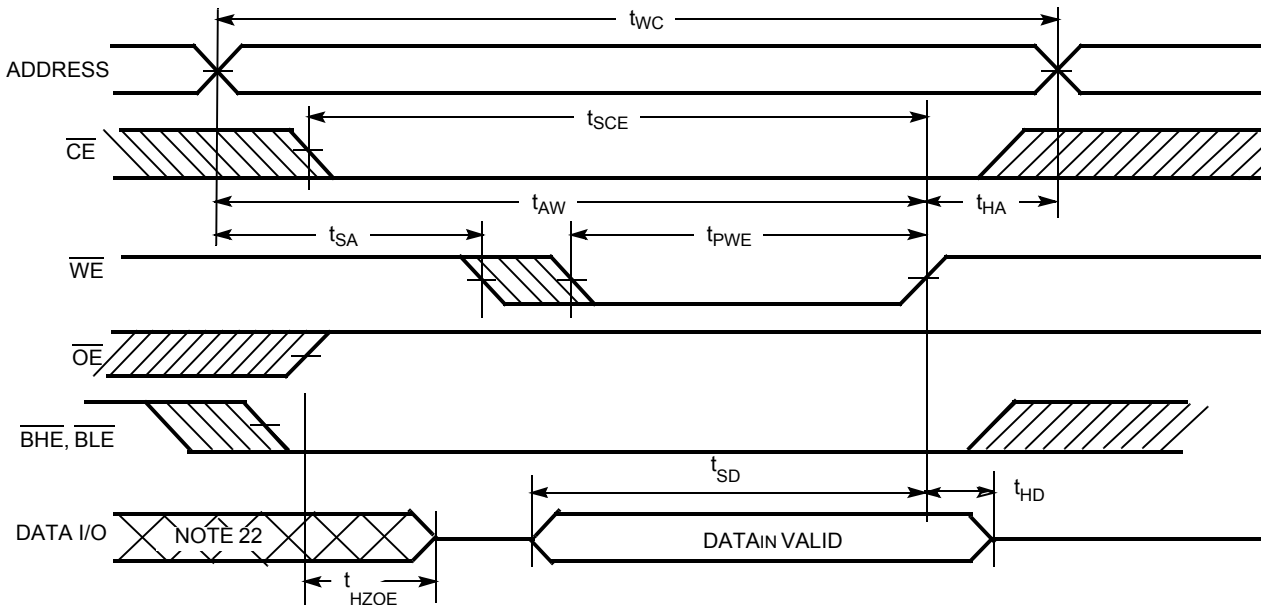
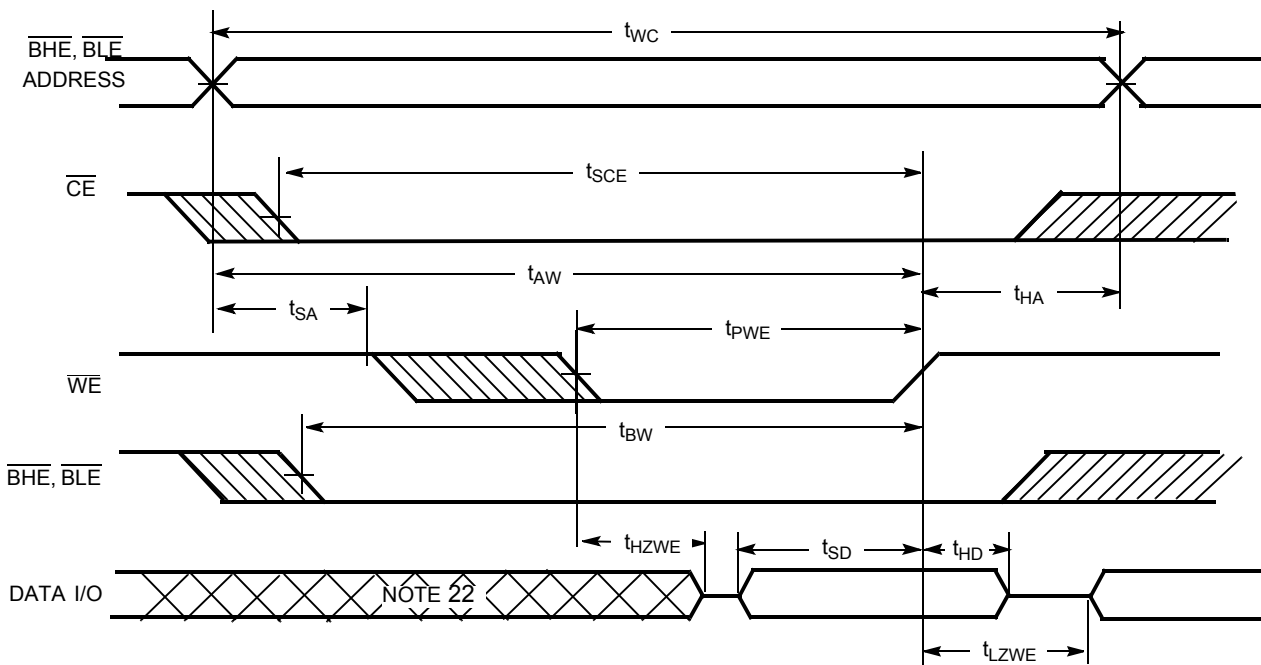

Figure 10. Write Cycle No. 4 (\overline{WE} Controlled, \overline{OE} LOW) [23]



Notes

- 20. Data I/O is high-impedance if \overline{OE} or \overline{BHE} and/or $\overline{BLE} = V_{IH}$.
- 21. If \overline{CE} goes HIGH simultaneously with \overline{WE} going HIGH, the output remains in a high-impedance state.
- 22. During this period the I/Os are in the output state and input signals should not be applied.
- 23. The minimum write pulse width for Write Cycle No. 4 (\overline{WE} controlled, \overline{OE} LOW) should be the sum of t_{SD} and t_{HZWE} .

Truth Table

$\overline{\text{CE}}$	$\overline{\text{OE}}$	$\overline{\text{WE}}$	$\overline{\text{BLE}}$	$\overline{\text{BHE}}$	I/O ₀ –I/O ₇	I/O ₈ –I/O ₁₅	Mode	Power
H	X	X	X	X	High Z	High Z	Power-down	Standby (I _{SB})
L	L	H	L	L	Data Out	Data Out	Read all bits	Active (I _{CC})
L	L	H	L	H	Data Out	High Z	Read lower bits only	Active (I _{CC})
L	L	H	H	L	High Z	Data Out	Read upper bits only	Active (I _{CC})
L	X	L	L	L	Data In	Data In	Write all bits	Active (I _{CC})
L	X	L	L	H	Data In	High Z	Write lower bits only	Active (I _{CC})
L	X	L	H	L	High Z	Data In	Write upper bits only	Active (I _{CC})
L	H	H	X	X	High Z	High Z	Selected, outputs disabled	Active (I _{CC})

Ordering Information

Speed (ns)	Ordering Code	Package Diagram	Package Type	Operating Range
10	CY7C1011DV33-10ZSXI	51-85087	44-pin TSOP II (Pb-free)	Industrial
	CY7C1011DV33-10BVXI	51-85150	48-ball VFBGA (Pb-free)	

Please contact your local Cypress sales representative for availability of these parts

Ordering Code Definitions

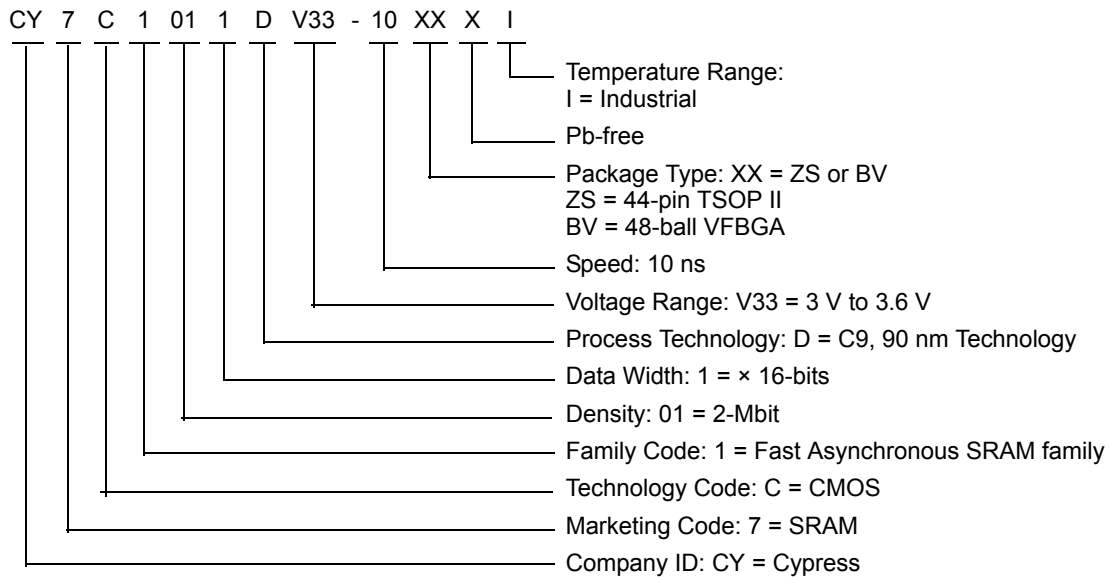

Acronyms

Acronym	Description
CMOS	Complementary Metal Oxide Semiconductor
\overline{CE}	Chip Enable
I/O	Input/Output
\overline{OE}	Output Enable
SRAM	Static Random Access Memory
TSOP	Thin Small Outline Package
TTL	Transistor-Transistor Logic
VFBGA	Very Fine-Pitch Ball Grid Array
\overline{WE}	Write Enable

Document Conventions

Units of Measure

Symbol	Unit of Measure
°C	degree Celsius
MHz	megahertz
μs	microsecond
μA	microampere
mA	milliampere
ns	nanosecond
%	percent
pF	picofarad
V	volt
W	watt

Document History

Document Title: CY7C1011DV33, 2-Mbit (128 K × 16) Static RAM				
Document Number: 38-05609				
Rev.	ECN No.	Issue Date	Orig. of Change	Description of Change
**	250650	See ECN	RKF	New data sheet.
*A	399070	See ECN	NXR	<p>Changed from Advance to Preliminary</p> <p>Changed address of Cypress Semiconductor Corporation on Page# 1 from "3901 North First Street" to "198 Champion Court"</p> <p>Removed TQFP Package from product offering</p> <p>Removed -15 speed bin</p> <p>Corrected DC voltage limits in maximum ratings section from -0.5 to -0.3V and $V_{CC} +0.5V$ to $V_{CC} +0.3V$</p> <p>Redefined I_{CC} values for Com'l and Ind'l temperature ranges</p> <p>I_{CC} (Com'l): Changed from 100, 80 and 70 mA to 90, 80 and 75 mA for 8, 10 and 12ns speed bins respectively</p> <p>I_{CC} (Ind'l): Changed from 80 and 70 mA to 90 and 85 mA for 10 and 12ns speed bins respectively</p> <p>Modified Note# 4 on AC Test Loads</p> <p>Added Static Discharge Voltage and latch-up current spec</p> <p>Added $V_{IH(max)}$ spec in Note# 2</p> <p>Changed reference voltage level for measurement of Hi-Z parameters from ± 500 mV to ± 200 mV</p> <p>Added Data Retention Characteristics Table and footnote on t_R</p> <p>Added Write Cycle (WE Controlled, OE HIGH During Write) Timing Diagram</p> <p>Changed package name for 44-pin TSOP II from Z to ZS</p> <p>Added 8 ns parts in the Ordering Information table</p> <p>Shaded Ordering Information Table</p>
*B	459073	See ECN	NXR	<p>Converted Preliminary to Final.</p> <p>Removed -8 and -12 Speed bins</p> <p>Removed Commercial Operating Range from product offering.</p> <p>Changed the description of I_{IX} from "Input Load Current" to "Input Leakage Current"</p> <p>Updated the Thermal Resistance table.</p> <p>Changed t_{HZBE} from 5 ns to 6 ns.</p> <p>Updated footnote #7 on High-Z parameter measurement</p> <p>Added footnote #12.</p> <p>Updated the Ordering Information and replaced Package Name column with Package Diagram in the Ordering Information table.</p>
*C	480177	See ECN	VKN	Added -10BVI product ordering code in the Ordering Information table.
*D	3059162	10/14/2010	PRAS	<p>Added Ordering Code Definitions.</p> <p>Updated Package Diagrams.</p>
*E	3098812	12/01/2010	PRAS	<p>Added Acronyms and Units of Measure.</p> <p>Minor edits and updated in new template.</p>
*F	3861347	01/08/2013	TAVA	<p>Updated Ordering Information (Updated part numbers).</p> <p>Updated Package Diagrams:</p> <p>spec 51-85087 – Changed revision from *C to *E.</p> <p>spec 51-85150 – Changed revision from *F to *H.</p>
*G	4187715	11/10/2013	MEMJ	<p>Updated in new template.</p> <p>Completing Sunset Review.</p>

Document History *(continued)*

Document Title: CY7C1011DV33, 2-Mbit (128 K × 16) Static RAM				
Document Number: 38-05609				
Rev.	ECN No.	Issue Date	Orig. of Change	Description of Change
*H	4567909	11/12/2014	MEMJ	<p>Updated Functional Description: Added "For a complete list of related resources, click here." at the end.</p> <p>Updated Switching Waveforms: Added Note 23 and referred the same note in Figure 10.</p> <p>Competing Sunset Review.</p>

Sales, Solutions, and Legal Information

Worldwide Sales and Design Support

Cypress maintains a worldwide network of offices, solution centers, manufacturer's representatives, and distributors. To find the office closest to you, visit us at [Cypress Locations](#).

Products

Automotive	cypress.com/go/automotive
Clocks & Buffers	cypress.com/go/clocks
Interface	cypress.com/go/interface
Lighting & Power Control	cypress.com/go/powerpsoc cypress.com/go/plc
Memory	cypress.com/go/memory
PSoC	cypress.com/go/psoc
Touch Sensing	cypress.com/go/touch
USB Controllers	cypress.com/go/USB
Wireless/RF	cypress.com/go/wireless

PSoC[®] Solutions

[psoc.cypress.com/solutions](#)
[PSoC 1](#) | [PSoC 3](#) | [PSoC 4](#) | [PSoC 5LP](#)

Cypress Developer Community

[Community](#) | [Forums](#) | [Blogs](#) | [Video](#) | [Training](#)

Technical Support

[cypress.com/go/support](#)

© Cypress Semiconductor Corporation, 2004-2014. The information contained herein is subject to change without notice. Cypress Semiconductor Corporation assumes no responsibility for the use of any circuitry other than circuitry embodied in a Cypress product. Nor does it convey or imply any license under patent or other rights. Cypress products are not warranted nor intended to be used for medical, life support, life saving, critical control or safety applications, unless pursuant to an express written agreement with Cypress. Furthermore, Cypress does not authorize its products for use as critical components in life-support systems where a malfunction or failure may reasonably be expected to result in significant injury to the user. The inclusion of Cypress products in life-support systems application implies that the manufacturer assumes all risk of such use and in doing so indemnifies Cypress against all charges.

Any Source Code (software and/or firmware) is owned by Cypress Semiconductor Corporation (Cypress) and is protected by and subject to worldwide patent protection (United States and foreign), United States copyright laws and international treaty provisions. Cypress hereby grants to licensee a personal, non-exclusive, non-transferable license to copy, use, modify, create derivative works of, and compile the Cypress Source Code and derivative works for the sole purpose of creating custom software and or firmware in support of licensee product to be used only in conjunction with a Cypress integrated circuit as specified in the applicable agreement. Any reproduction, modification, translation, compilation, or representation of this Source Code except as specified above is prohibited without the express written permission of Cypress.

Disclaimer: CYPRESS MAKES NO WARRANTY OF ANY KIND, EXPRESS OR IMPLIED, WITH REGARD TO THIS MATERIAL, INCLUDING, BUT NOT LIMITED TO, THE IMPLIED WARRANTIES OF MERCHANTABILITY AND FITNESS FOR A PARTICULAR PURPOSE. Cypress reserves the right to make changes without further notice to the materials described herein. Cypress does not assume any liability arising out of the application or use of any product or circuit described herein. Cypress does not authorize its products for use as critical components in life-support systems where a malfunction or failure may reasonably be expected to result in significant injury to the user. The inclusion of Cypress' product in a life-support systems application implies that the manufacturer assumes all risk of such use and in doing so indemnifies Cypress against all charges.

Use may be limited by and subject to the applicable Cypress software license agreement.

Looking for pricing, stock, or lifecycle information?

Click below to explore more details on WIN SOURCE:

 [View CY7C1011DV33-10BVI on WIN SOURCE](#)

 [Infineon Technologies](#) Information

Optimize Your Supply Chain with WIN SOURCE Solutions

-  Global Sourcing Solution
-  Obsolete Management
-  Cost Control Management
-  Shortage Management
-  Alternative Solution
-  Excess Inventory Management