



**THE DATASHEET OF  
CY62138FLL-45SXI**





**Please note that Cypress is an Infineon Technologies Company.**

The document following this cover page is marked as “Cypress” document as this is the company that originally developed the product. Please note that Infineon will continue to offer the product to new and existing customers as part of the Infineon product portfolio.

**Continuity of document content**

The fact that Infineon offers the following product as part of the Infineon product portfolio does not lead to any changes to this document. Future revisions will occur when appropriate, and any changes will be set out on the document history page.

**Continuity of ordering part numbers**

Infineon continues to support existing part numbers. Please continue to use the ordering part numbers listed in the datasheet for ordering.

## Features

- High speed: 45 ns
- Wide voltage range: 4.5 V to 5.5 V
- Pin compatible with CY62138V
- Ultra low standby power
  - Typical standby current: 1 μA
  - Maximum standby current: 5 μA
- Ultra low active power
  - Typical active current: 1.6 mA @ f = 1 MHz
- Easy memory expansion with  $\overline{CE}_1$ ,  $CE_2$ , and  $\overline{OE}$  features
- Automatic power down when deselected
- Complementary metal oxide semiconductor (CMOS) for optimum speed and power
- Available in Pb-free 32-pin SOIC and 32-pin thin small outline package (TSOP) II packages

## Functional Description

The CY62138F is a high performance CMOS static RAM organized as 256K words by 8 bits. This device features advanced circuit design to provide ultra low active current. This is ideal for providing More Battery Life™ (MoBL®) in portable applications. The device also has an automatic power down feature that significantly reduces power consumption when addresses are not toggling. Placing the device into standby mode reduces power consumption by more than 99% when deselected ( $\overline{CE}_1$  HIGH or  $CE_2$  LOW).

To write to the device, take Chip Enable ( $\overline{CE}_1$  LOW and  $CE_2$  HIGH) and Write Enable ( $\overline{WE}$ ) inputs LOW. Data on the eight I/O pins ( $I/O_0$  through  $I/O_7$ ) is then written into the location specified on the address pins ( $A_0$  through  $A_{17}$ ).

To read from the device, take Chip Enable ( $\overline{CE}_1$  LOW and  $CE_2$  HIGH) and output enable ( $\overline{OE}$ ) LOW while forcing Write Enable ( $\overline{WE}$ ) HIGH. Under these conditions, the contents of the memory location specified by the address pins appear on the I/O pins.

The eight input and output pins ( $I/O_0$  through  $I/O_7$ ) are placed in a high impedance state when the device is deselected ( $\overline{CE}_1$  HIGH or  $CE_2$  LOW), the outputs are disabled ( $\overline{OE}$  HIGH), or during a write operation ( $\overline{CE}_1$  LOW and  $CE_2$  HIGH and  $\overline{WE}$  LOW).

The CY62138F device is suitable for interfacing with processors that have TTL I/P levels. It is not suitable for processors that require CMOS I/P levels. Please see [Electrical Characteristics on page 4](#) for more details and suggested alternatives.

For a complete list of related documentation, click [here](#).

## Logic Block Diagram

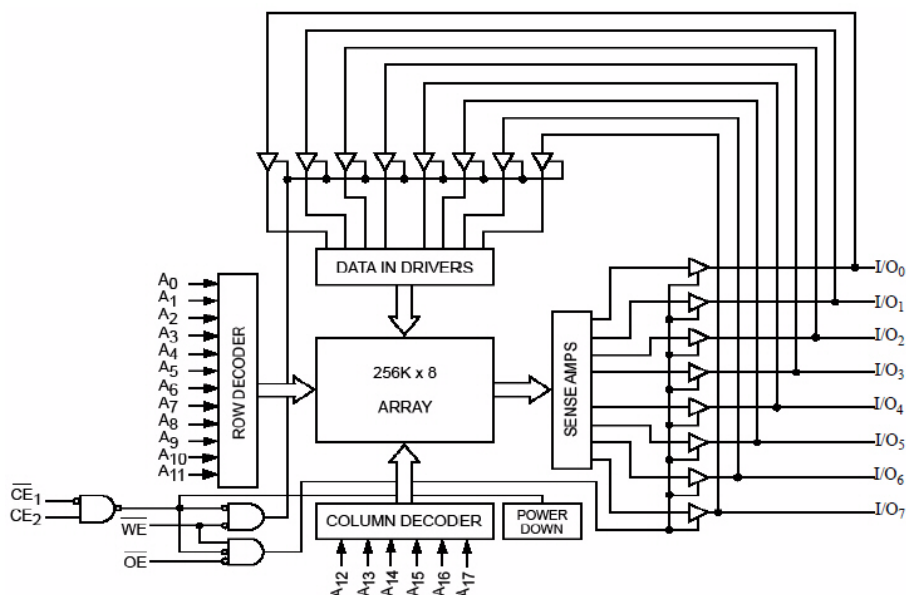

## Contents

<b>Pin Configurations</b> .....	<b>3</b>	<b>Ordering Information</b> .....	<b>12</b>
<b>Product Portfolio</b> .....	<b>3</b>	Ordering Code Definitions .....	12
<b>Maximum Ratings</b> .....	<b>4</b>	<b>Package Diagrams</b> .....	<b>13</b>
<b>Operating Range</b> .....	<b>4</b>	<b>Acronyms</b> .....	<b>15</b>
<b>Electrical Characteristics</b> .....	<b>4</b>	<b>Documents Conventions</b> .....	<b>15</b>
<b>Capacitance</b> .....	<b>5</b>	Units of Measure .....	15
<b>Thermal Resistance</b> .....	<b>5</b>	<b>Document History Page</b> .....	<b>16</b>
<b>AC Test Loads and Waveforms</b> .....	<b>5</b>	<b>Sales, Solutions, and Legal Information</b> .....	<b>18</b>
<b>Data Retention Characteristics</b> .....	<b>6</b>	Worldwide Sales and Design Support .....	18
<b>Data Retention Waveform</b> .....	<b>6</b>	Products .....	18
<b>Switching Characteristics</b> .....	<b>7</b>	PSoC <sup>®</sup> Solutions .....	18
<b>Switching Waveforms</b> .....	<b>8</b>	Cypress Developer Community .....	18
<b>Truth Table</b> .....	<b>11</b>	Technical Support .....	18

## Pin Configurations

Figure 1. 32-pin SOIC/TSOP II pinout (Top View)

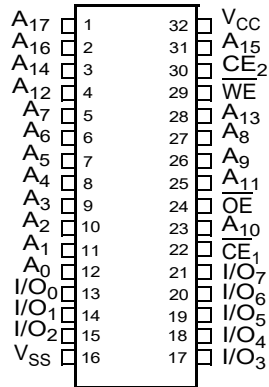

## Product Portfolio

Product	V <sub>CC</sub> Range (V)			Speed (ns)	Power Dissipation					
					Operating I <sub>CC</sub> (mA)				Standby I <sub>SB2</sub> (μA)	
	f = 1 MHz		f = f <sub>max</sub>							
	Min	Typ <sup>[1]</sup>	Max		Typ <sup>[1]</sup>	Max	Typ <sup>[1]</sup>	Max	Typ <sup>[1]</sup>	Max
CY62138FLL	4.5 V	5.0 V	5.5 V	45	1.6	2.5	13	18	1	5

**Note**

1. Typical values are included for reference only and are not guaranteed or tested. Typical values are measured at V<sub>CC</sub> = V<sub>CC(typ)</sub>, T<sub>A</sub> = 25 °C.

## Maximum Ratings

Exceeding maximum ratings may impair the useful life of the device. These user guidelines are not tested.

Storage temperature .....	-65 °C to + 150 °C
Ambient temperature with power applied .....	-55 °C to + 125 °C
Supply voltage to ground potential .....	-0.5 V to 6.0 V ( $V_{CCmax} + 0.5 V$ )
DC voltage applied to outputs in High Z state <sup>[2, 3]</sup> .....	-0.5 V to 6.0 V ( $V_{CCmax} + 0.5 V$ )

DC Input Voltage <sup>[2, 3]</sup> .....	-0.5 V to 6.0 V ( $V_{CCmax} + 0.5 V$ )
Output Current into Outputs (LOW) .....	20 mA
Static Discharge Voltage (MIL-STD-883, Method 3015) .....	> 2001 V
Latch-up Current .....	> 200 mA

## Operating Range

Device	Range	Ambient Temperature	$V_{CC}$ <sup>[4]</sup>
CY62138FLL	Industrial	-40 °C to +85 °C	4.5 V to 5.5 V

## Electrical Characteristics

Over the Operating Range

Parameter	Description	Test Conditions		45 ns			Unit
				Min	Typ <sup>[5]</sup>	Max	
$V_{OH}$	Output HIGH voltage	$V_{CC} = 4.5 V$	$I_{OH} = -1.0 mA$	2.4	-	-	V
		$V_{CC} = 5.5 V$	$I_{OH} = -0.1 mA$	-	-	3.4 <sup>[6]</sup>	
$V_{OL}$	Output LOW voltage	$I_{OL} = 2.1 mA$		-	-	0.4	V
$V_{IH}$	Input HIGH voltage	$V_{CC} = 4.5 V$ to 5.5 V		2.2	-	$V_{CC} + 0.5$	V
$V_{IL}$	Input LOW voltage	$V_{CC} = 4.5 V$ to 5.5 V		-0.5	-	0.8	V
$I_{IX}$	Input leakage current	$GND \leq V_I \leq V_{CC}$		-1	-	+1	$\mu A$
$I_{OZ}$	Output leakage current	$GND \leq V_O \leq V_{CC}$ , Output disabled		-1	-	+1	$\mu A$
$I_{CC}$	$V_{CC}$ operating supply Current	$f = f_{max} = 1/t_{RC}$	$V_{CC} = V_{CC(max)}$ , $I_{OUT} = 0 mA$ , CMOS levels	-	13	18	mA
		$f = 1 MHz$		-	1.6	2.5	
$I_{SB2}$ <sup>[7]</sup>	Automatic CE Power-down current CMOS inputs	$\overline{CE}_1 \geq V_{CC} - 0.2 V$ or $CE_2 \leq 0.2 V$ , $V_{IN} \geq V_{CC} - 0.2 V$ or $V_{IN} \leq 0.2 V$ , $f = 0$ , $V_{CC} = V_{CC(max)}$		-	1	5	$\mu A$

### Notes

- $V_{IL(min)}$  = -2.0 V for pulse durations less than 20 ns.
- $V_{IH(max)}$  =  $V_{CC} + 0.75 V$  for pulse durations less than 20 ns.
- Full device AC operation assumes a 100  $\mu s$  ramp time from 0 to  $V_{CC(min)}$  and 200  $\mu s$  wait time after  $V_{CC}$  stabilization.
- Typical values are included for reference only and are not guaranteed or tested. Typical values are measured at  $V_{CC} = V_{CC(typ)}$ ,  $T_A = 25^\circ C$ .
- Please note that the maximum  $V_{OH}$  limit does not exceed minimum CMOS  $V_{IH}$  of 3.5 V. If you are interfacing this SRAM with 5 V legacy processors that require a minimum  $V_{IH}$  of 3.5 V, please refer to Application Note AN6081 for technical details and options you may consider.
- Chip enables ( $CE_1$  and  $CE_2$ ) must be at CMOS level to meet the  $I_{SB2} / I_{CCDR}$  spec. Other inputs can be left floating.

## Capacitance

Parameter <sup>[8]</sup>	Description	Test Conditions	Max	Unit
C <sub>IN</sub>	Input capacitance	T <sub>A</sub> = 25 °C, f = 1 MHz, V <sub>CC</sub> = V <sub>CC(typ)</sub>	10	pF
C <sub>OUT</sub>	Output capacitance		10	pF

## Thermal Resistance

Parameter <sup>[8]</sup>	Description	Test Conditions	32-pin SOIC	32-pin TSOP II	Unit
Θ <sub>JA</sub>	Thermal resistance (junction to ambient)	Still Air, soldered on a 3 × 4.5 inch, four-layer printed circuit board	59.0	56.0	°C/W
Θ <sub>JC</sub>	Thermal resistance (junction to case)		30.0	14.0	°C/W

## AC Test Loads and Waveforms

Figure 2. AC Test Loads and Waveforms

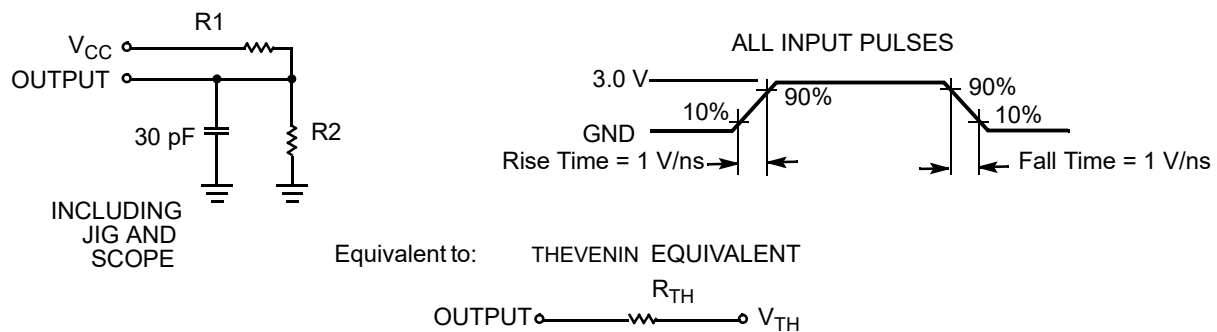

Parameters	5.0 V	Unit
R <sub>1</sub>	1800	Ω
R <sub>2</sub>	990	Ω
R <sub>TH</sub>	639	Ω
V <sub>TH</sub>	1.77	V

### Note

8. Tested initially and after any design or process changes that may affect these parameters.

## Data Retention Characteristics

Over the Operating Range

Parameter	Description	Conditions	Min	Typ <sup>[9]</sup>	Max	Unit
$V_{DR}$	$V_{CC}$ for Data retention	–	2.0	–	–	V
$I_{CCDR}$ <sup>[10]</sup>	Data retention current	$V_{CC} = V_{DR}$ , $\overline{CE}_1 \geq V_{CC} - 0.2\text{ V}$ or $CE_2 \leq 0.2\text{ V}$ , $V_{IN} \geq V_{CC} - 0.2\text{ V}$ or $V_{IN} \leq 0.2\text{ V}$	–	1	5	$\mu\text{A}$
$t_{CDR}$ <sup>[9]</sup>	Chip deselect to data retention time	–	0	–	–	ns
$t_R$ <sup>[11]</sup>	Operation recovery time	–	45	–	–	ns

## Data Retention Waveform

Figure 3. Data Retention Waveform<sup>[12]</sup>

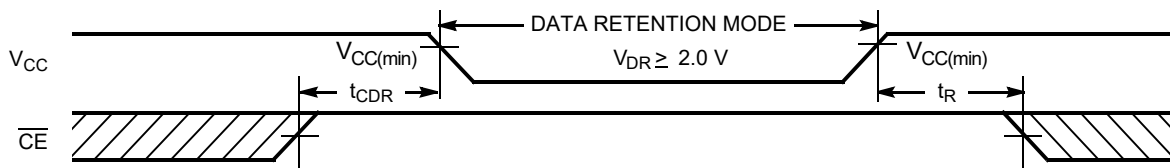

### Notes

9. Tested initially and after any design or process changes that may affect these parameters. Typical values are included for reference only and are not guaranteed or tested. Typical values are measured at  $V_{CC} = V_{CC(typ)}$ ;  $T_A = 25^\circ\text{C}$ .
10. Chip enables ( $CE_1$  and  $CE_2$ ) must be at CMOS level to meet the  $I_{SB2} / I_{CCDR}$  spec. Other inputs can be left floating.
11. Full device AC operation requires linear  $V_{CC}$  ramp from  $V_{DR}$  to  $V_{CC(min)} \geq 100\ \mu\text{s}$  or stable at  $V_{CC(min)} \geq 100\ \mu\text{s}$ .
12.  $\overline{CE}$  is the logical combination of  $CE_1$  and  $CE_2$ . When  $CE_1$  is LOW and  $CE_2$  is HIGH,  $\overline{CE}$  is LOW; when  $CE_1$  is HIGH or  $CE_2$  is LOW,  $\overline{CE}$  is HIGH.

## Switching Characteristics

Over the Operating Range

Parameter <sup>[13, 14]</sup>	Description	45 ns		Unit
		Min	Max	
<b>Read Cycle</b>				
$t_{RC}$	Read cycle time	45	–	ns
$t_{AA}$	Address to data valid	–	45	ns
$t_{OHA}$	Data hold from address change	10	–	ns
$t_{ACE}$	$\overline{CE}_1$ LOW and $\overline{CE}_2$ HIGH to data valid	–	45	ns
$t_{DOE}$	$\overline{OE}$ LOW to data valid	–	22	ns
$t_{LZOE}$	$\overline{OE}$ LOW to low Z <sup>[15]</sup>	5	–	ns
$t_{HZOE}$	$\overline{OE}$ HIGH to high Z <sup>[15, 16]</sup>	–	18	ns
$t_{LZCE}$	$\overline{CE}_1$ LOW and $\overline{CE}_2$ HIGH to low Z <sup>[15]</sup>	10	–	ns
$t_{HZCE}$	$\overline{CE}_1$ HIGH or $\overline{CE}_2$ LOW to high Z <sup>[15, 16]</sup>	–	18	ns
$t_{PU}$	$\overline{CE}_1$ LOW and $\overline{CE}_2$ HIGH to power-up	0	–	ns
$t_{PD}$	$\overline{CE}_1$ HIGH or $\overline{CE}_2$ LOW to power-down	–	45	ns
<b>Write Cycle <sup>[17, 18]</sup></b>				
$t_{WC}$	Write cycle time	45	–	ns
$t_{SCE}$	$\overline{CE}_1$ LOW and $\overline{CE}_2$ HIGH to write end	35	–	ns
$t_{AW}$	Address setup to write end	35	–	ns
$t_{HA}$	Address hold from write end	0	–	ns
$t_{SA}$	Address setup to write start	0	–	ns
$t_{PWE}$	$\overline{WE}$ pulse width	35	–	ns
$t_{SD}$	Data setup to write end	25	–	ns
$t_{HD}$	Data hold from write end	0	–	ns
$t_{HZWE}$	$\overline{WE}$ LOW to high Z <sup>[15, 16]</sup>	–	18	ns
$t_{LZWE}$	$\overline{WE}$ HIGH to low Z <sup>[15]</sup>	10	–	ns

### Notes

13. In an earlier revision of this device, under a specific application condition, READ and WRITE operations were limited to switching of the chip enable signal as described in the Application Note [AN66311](#). However, the issue has been fixed and in production now, and hence, this Application Notes is no longer applicable. It is available for download on our website as it contains information on the date code of the parts, beyond which the fix has been in production.
14. Test conditions for all parameters other than tri-state parameters assume signal transition time of 3 ns (1 V/ns) or less, timing reference levels of  $V_{CC(typ)}/2$ , input pulse levels of 0 to  $V_{CC(typ)}$ , and output loading of the specified  $I_{OL}/I_{OH}$  as shown in the [Figure 2 on page 5](#).
15. At any given temperature and voltage condition,  $t_{HZCE}$  is less than  $t_{LZCE}$ ,  $t_{HZOE}$  is less than  $t_{LZOE}$ , and  $t_{HZWE}$  is less than  $t_{LZWE}$  for any given device.
16.  $t_{HZOE}$ ,  $t_{HZCE}$ , and  $t_{HZWE}$  transitions are measured when the outputs enter a high impedance state.
17. The internal write time of the memory is defined by the overlap of  $\overline{WE}$ ,  $\overline{CE}_1 = V_{IL}$ , and  $\overline{CE}_2 = V_{IH}$ . All signals must be ACTIVE to initiate a write and any of these signals can terminate a write by going INACTIVE. The data input setup and hold timing must be referenced to the edge of the signal that terminates the write.
18. The minimum write cycle pulse width should be equal to the sum of  $t_{HZWE}$  and  $t_{SD}$ .

## Switching Waveforms

Figure 4. Read Cycle No. 1 (Address Transition Controlled) [19, 20]

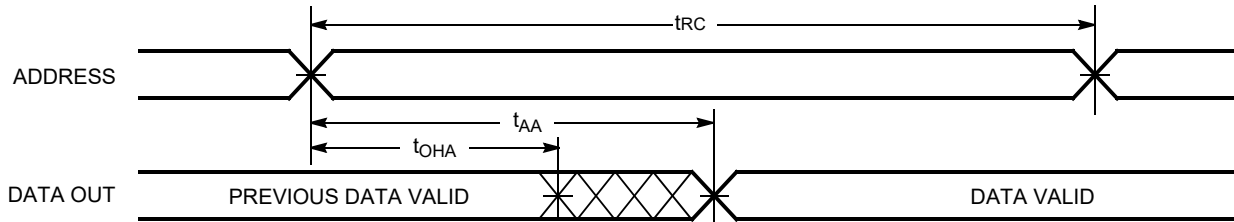
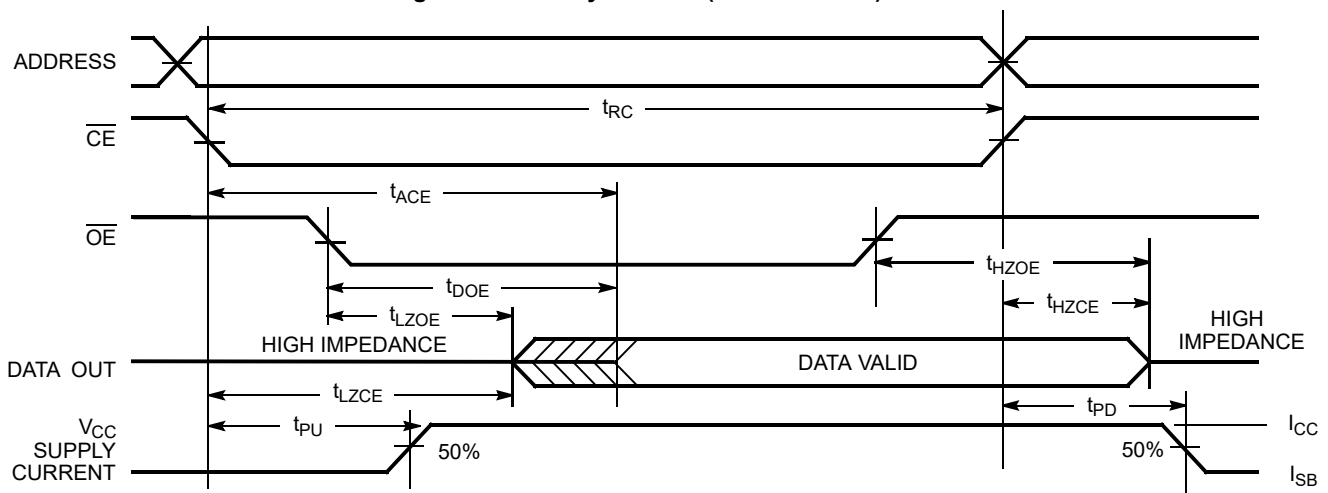

Figure 5. Read Cycle No. 2 ( $\overline{\text{OE}}$  Controlled) [20, 21, 22]



### Notes

19. The device is continuously selected.  $\overline{\text{OE}}$ ,  $\overline{\text{CE}}_1 = V_{\text{IL}}$ ,  $\text{CE}_2 = V_{\text{IH}}$ .

20.  $\overline{\text{WE}}$  is HIGH for read cycle.

21. Address valid before or similar to  $\overline{\text{CE}}_1$  transition LOW and  $\text{CE}_2$  transition HIGH.

22.  $\overline{\text{CE}}$  is the logical combination of  $\overline{\text{CE}}_1$  and  $\text{CE}_2$ . When  $\text{CE}_1$  is LOW and  $\text{CE}_2$  is HIGH,  $\overline{\text{CE}}$  is LOW; when  $\overline{\text{CE}}_1$  is HIGH or  $\text{CE}_2$  is LOW,  $\overline{\text{CE}}$  is HIGH.

Switching Waveforms (continued)

Figure 6. Write Cycle No. 1 ( $\overline{WE}$  Controlled) [23, 24, 25, 26]

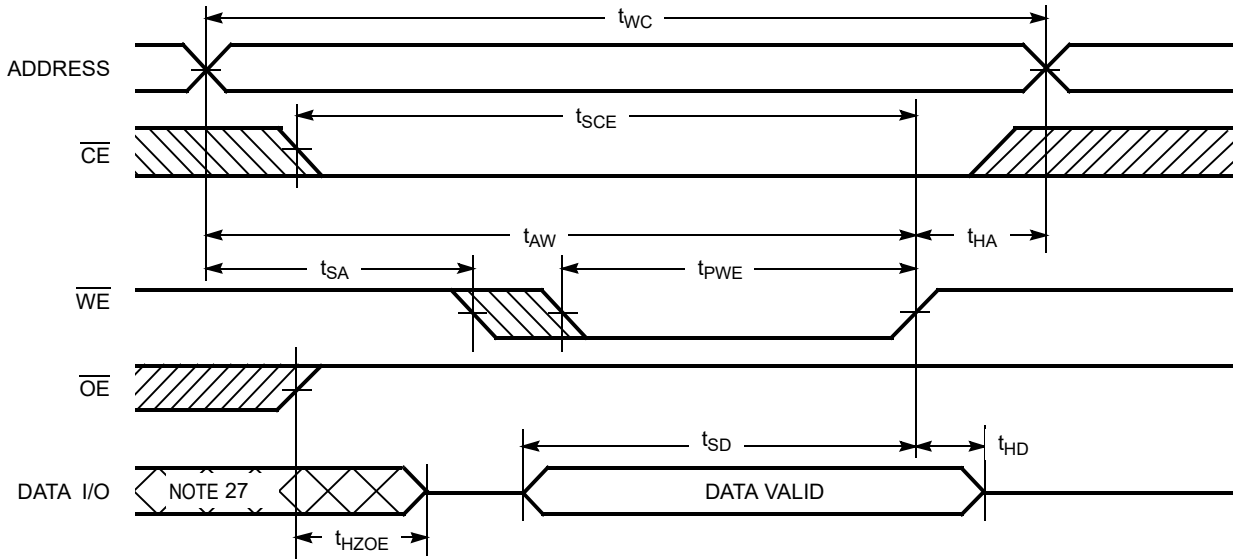
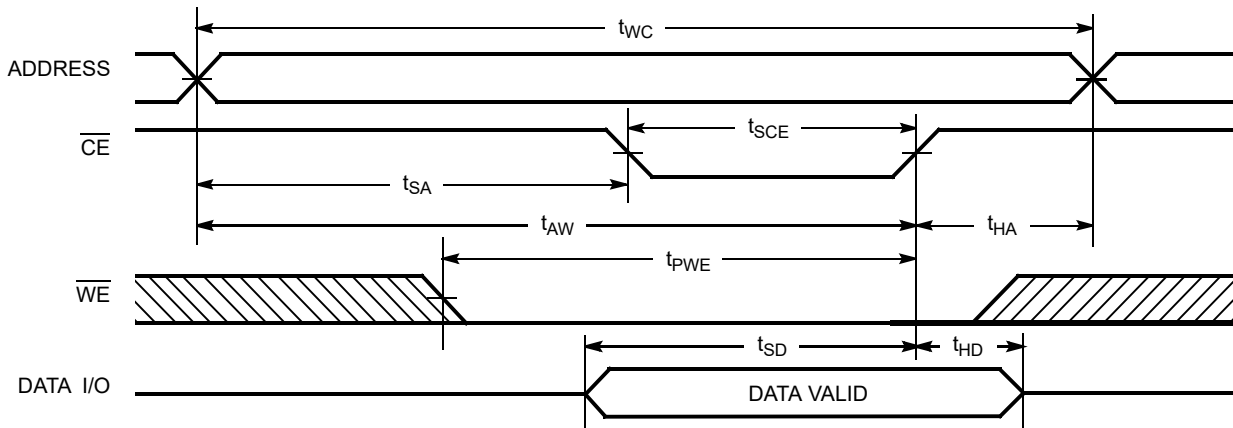

Figure 7. Write Cycle No. 2 ( $\overline{CE}_1$  or  $\overline{CE}_2$  Controlled) [23, 24, 25, 26]



Notes

23.  $\overline{CE}$  is the logical combination of  $\overline{CE}_1$  and  $CE_2$ . When  $\overline{CE}_1$  is LOW and  $CE_2$  is HIGH,  $\overline{CE}$  is LOW; when  $\overline{CE}_1$  is HIGH or  $CE_2$  is LOW,  $\overline{CE}$  is HIGH.
24. The internal write time of the memory is defined by the overlap of  $\overline{WE}$ ,  $\overline{CE}_1 = V_{IL}$ , and  $CE_2 = V_{IH}$ . All signals must be ACTIVE to initiate a write and any of these signals can terminate a write by going INACTIVE. The data input setup and hold timing must be referenced to the edge of the signal that terminates the write.
25. Data I/O is high impedance if  $\overline{OE} = V_{IH}$ .
26. If  $\overline{CE}_1$  goes HIGH or  $CE_2$  goes LOW simultaneously with  $\overline{WE}$  HIGH, the output remains in high impedance state.
27. During this period, the I/Os are in output state. Do not apply input signals.

Switching Waveforms (continued)

Figure 8. Write Cycle No. 3 ( $\overline{WE}$  Controlled,  $\overline{OE}$  LOW) [28, 29, 30]

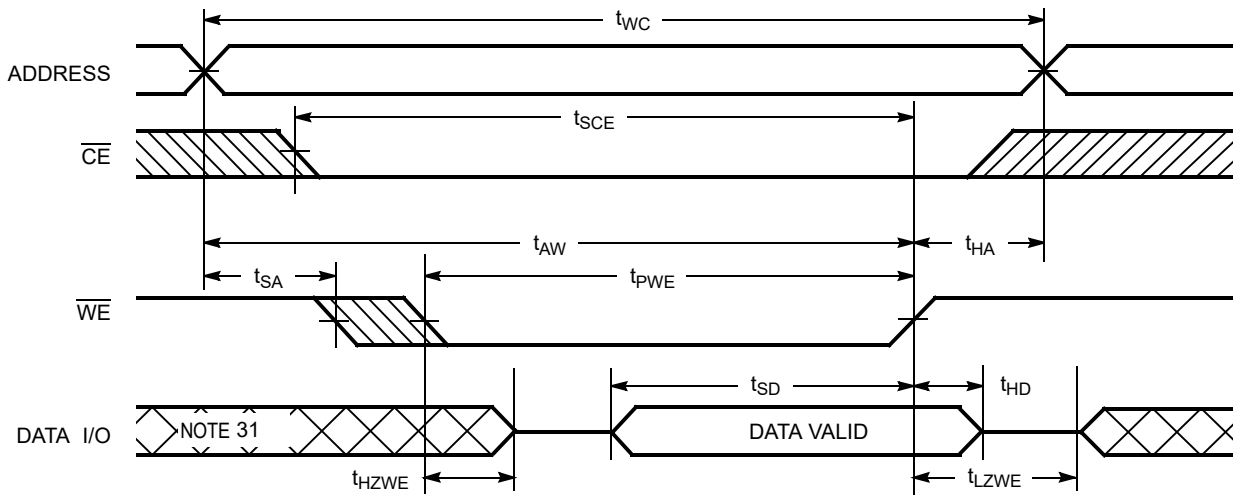

Notes

- 28.  $\overline{CE}$  is the logical combination of  $\overline{CE}_1$  and  $\overline{CE}_2$ . When  $\overline{CE}_1$  is LOW and  $\overline{CE}_2$  is HIGH,  $\overline{CE}$  is LOW; when  $\overline{CE}_1$  is HIGH or  $\overline{CE}_2$  is LOW,  $\overline{CE}$  is HIGH.
- 29. If  $\overline{CE}_1$  goes HIGH or  $\overline{CE}_2$  goes LOW simultaneously with  $\overline{WE}$  HIGH, the output remains in high impedance state.
- 30. The minimum write cycle pulse width should be equal to the sum of  $t_{HZWE}$  and  $t_{SD}$ .
- 31. During this period, the I/Os are in output state. Do not apply input signals.

**Truth Table**

$\overline{CE}_1$	$\overline{CE}_2$	$\overline{WE}$	$\overline{OE}$	Inputs/Outputs	Mode	Power
H	X <sup>[32]</sup>	X	X	High Z	Deselect/Power-down	Standby ( $I_{SB}$ )
X <sup>[32]</sup>	L	X	X	High Z	Deselect/Power-down	Standby ( $I_{SB}$ )
L	H	H	L	Data out	Read	Active ( $I_{CC}$ )
L	H	H	H	High Z	Output disabled	Active ( $I_{CC}$ )
L	H	L	X	Data in	Write	Active ( $I_{CC}$ )

**Note**

32. The 'X' (Don't care) state for the Chip enables ( $\overline{CE}_1$  and  $\overline{CE}_2$ ) in the truth table refer to the logic state (either HIGH or LOW). Intermediate voltage levels on these pins is not permitted.

### Ordering Information

Speed (ns)	Ordering Code	Package Diagram	Package Type	Operating Range
45	CY62138FLL-45SXI	51-85081	32-pin SOIC (Pb-free)	Industrial

Contact your local Cypress sales representative for availability of these parts.

### Ordering Code Definitions

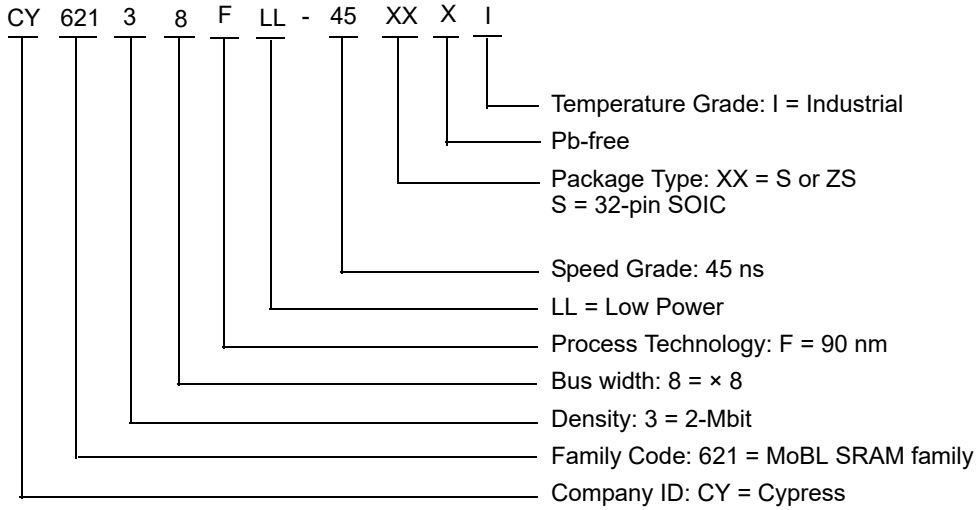

### Package Diagrams

Figure 9. 32-pin SOIC (450 Mils) S32.45/SZ32.45 Package Outline, 51-85081

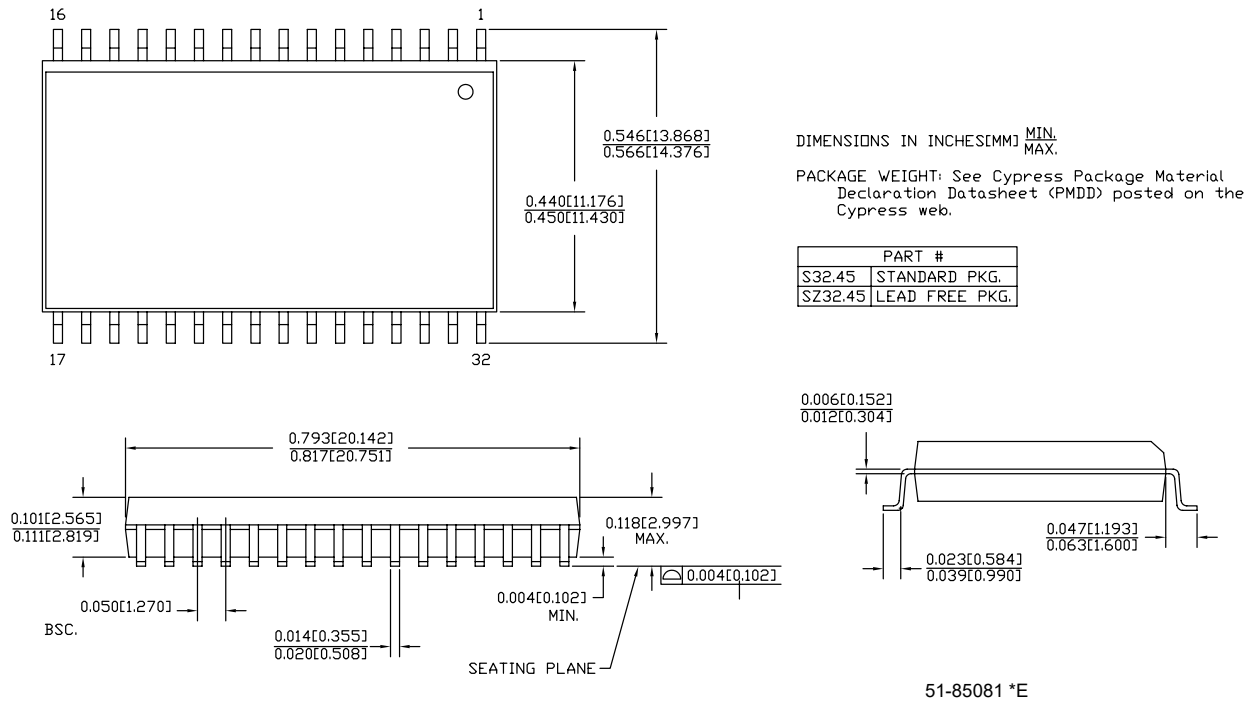

Package Diagrams (continued)

Figure 10. 32-pin TSOP II (20.95 × 11.76 × 1.0 mm) ZS32 Package Outline, 51-85095

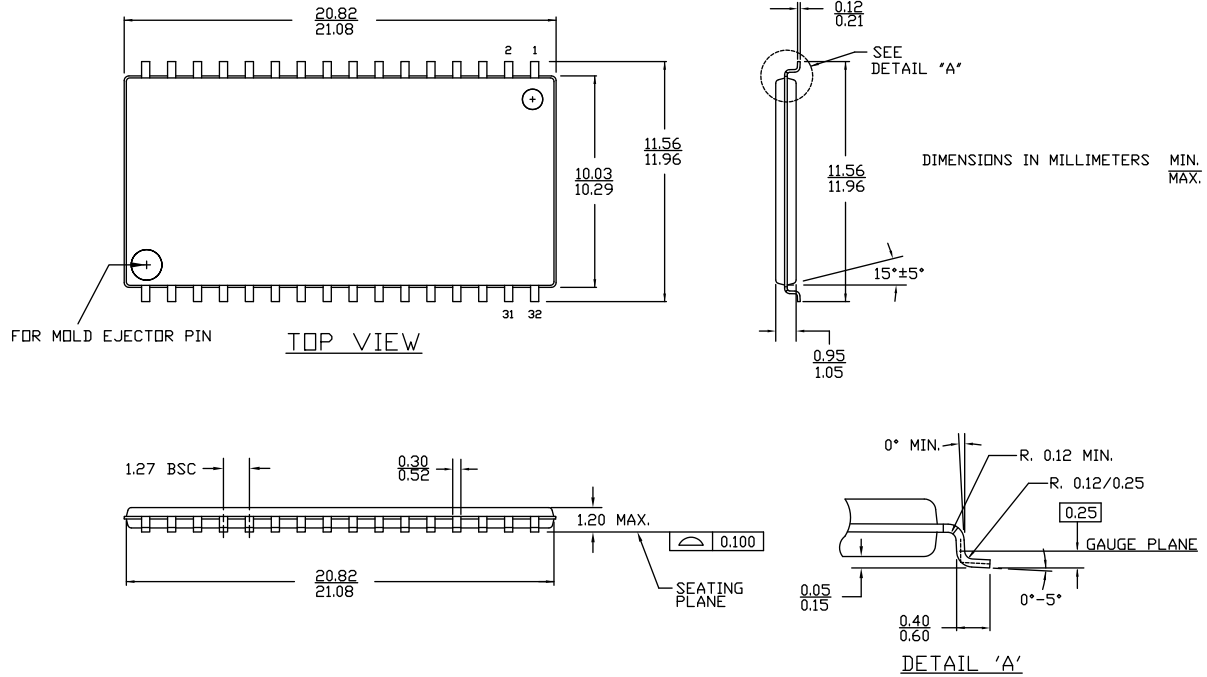

51-85095 \*D

### Acronyms

Acronym	Description
CMOS	Complementary Metal Oxide Semiconductor
I/O	Input/Output
$\overline{OE}$	Output Enable
SOIC	Small Outline Integrated Circuit
SRAM	Static Random Access Memory
TSOP	Thin Small Outline Package
$\overline{WE}$	Write Enable

### Documents Conventions

#### Units of Measure

Symbol	Unit of Measure
°C	degree Celsius
MHz	megahertz
$\mu A$	microampere
$\mu s$	microsecond
mA	milliampere
ns	nanosecond
$\Omega$	ohm
%	percent
pF	picofarad
V	volt
W	watt

**Document History Page**

Document Title: CY62138F MoBL <sup>®</sup> , 2-Mbit (256K × 8) Static RAM Document Number: 001-13194				
Rev.	ECN No.	Orig. of Change	Submission Date	Description of Change
**	797956	VKN	02/23/2007	New data sheet.
*A	940341	VKN	04/10/2007	Updated <a href="#">Electrical Characteristics</a> : Added Note 7 and referred the same note in I <sub>SB2</sub> parameter.
*B	3055174	RAME	13/10/2010	Updated <a href="#">Ordering Information</a> : No change in part numbers. Added <a href="#">Ordering Code Definitions</a> . Updated <a href="#">Package Diagrams</a> : spec 51-85081 – Changed revision from *B to *C. spec 51-85095 – Changed revision from ** to *A. Added <a href="#">Acronyms</a> and <a href="#">Units of Measure</a> . Updated footnotes across the document. Updated to new template.
*C	3061313	RAME	15/10/2010	Minor change: Replaced “I/O” with “I/O” in all instances across the document.
*D	3232735	RAME	04/18/2011	Updated <a href="#">Functional Description</a> : Removed Note “For best practice recommendations, refer to the Cypress application note “System Design Guidelines” at <a href="http://www.cypress.com">http://www.cypress.com</a> link” and its reference. Completing Sunset Review.
*E	3287636	RAME	06/20/2011	Updated <a href="#">Package Diagrams</a> : spec 51-85095 – Changed revision from *A to *B. Updated to new template.
*F	3846281	TAVA	12/19/2012	Updated <a href="#">Ordering Information</a> : Updated part numbers. Updated <a href="#">Package Diagrams</a> : spec 51-85081 – Changed revision from *C to *E.
*G	4013949	MEMJ	06/04/2013	Updated <a href="#">Functional Description</a> : Updated description. Updated <a href="#">Electrical Characteristics</a> : Added one more Test Condition “V <sub>CC</sub> = 5.5 V, I <sub>OH</sub> = -0.1 mA” for V <sub>OH</sub> parameter and added maximum value corresponding to that Test Condition. Added Note 6 and referred the same note in maximum value for V <sub>OH</sub> parameter corresponding to Test Condition “V <sub>CC</sub> = 5.5 V, I <sub>OH</sub> = -0.1 mA”.
*H	4099045	VINI	08/19/2013	Updated <a href="#">Switching Characteristics</a> : Added Note 13 and referred the same note in “Parameter” column. Updated to new template.
*I	4380445	NILE	05/15/2014	Updated <a href="#">Switching Characteristics</a> : Added Note 18 and referred the same note in “Write Cycle”. Updated <a href="#">Switching Waveforms</a> : Added Note 30 and referred the same note in <a href="#">Figure 8</a> . Completing Sunset Review.
*J	4578447	NILE	01/16/2015	Updated <a href="#">Functional Description</a> : Added “For a complete list of related documentation, click <a href="#">here</a> .” at the end. Updated <a href="#">Package Diagrams</a> : spec 51-85095 – Changed revision from *B to *C. Updated to new template.
*K	4753651	NILE	04/05/2015	Updated <a href="#">Thermal Resistance</a> : Updated all values of $\Theta_{JA}$ and $\Theta_{JC}$ parameters. Completing Sunset Review.

**Document History Page** (continued)

Document Title: CY62138F MoBL <sup>®</sup> , 2-Mbit (256K × 8) Static RAM Document Number: 001-13194				
Rev.	ECN No.	Orig. of Change	Submission Date	Description of Change
*L	4780983	NILE	05/29/2015	Updated <a href="#">Package Diagrams</a> : spec 51-85095 – Changed revision from *C to *D.
*M	5732692	NILE	05/10/2017	Updated to new template. Completing Sunset Review.
*N	6526615	NILE	03/29/2019	Updated to new template.

## Sales, Solutions, and Legal Information

### Worldwide Sales and Design Support

Cypress maintains a worldwide network of offices, solution centers, manufacturer's representatives, and distributors. To find the office closest to you, visit us at [Cypress Locations](#).

#### Products

Arm <sup>®</sup> Cortex <sup>®</sup> Microcontrollers	<a href="http://cypress.com/arm">cypress.com/arm</a>
Automotive	<a href="http://cypress.com/automotive">cypress.com/automotive</a>
Clocks & Buffers	<a href="http://cypress.com/clocks">cypress.com/clocks</a>
Interface	<a href="http://cypress.com/interface">cypress.com/interface</a>
Internet of Things	<a href="http://cypress.com/iot">cypress.com/iot</a>
Memory	<a href="http://cypress.com/memory">cypress.com/memory</a>
Microcontrollers	<a href="http://cypress.com/mcu">cypress.com/mcu</a>
PSoC	<a href="http://cypress.com/psoc">cypress.com/psoc</a>
Power Management ICs	<a href="http://cypress.com/pmic">cypress.com/pmic</a>
Touch Sensing	<a href="http://cypress.com/touch">cypress.com/touch</a>
USB Controllers	<a href="http://cypress.com/usb">cypress.com/usb</a>
Wireless Connectivity	<a href="http://cypress.com/wireless">cypress.com/wireless</a>

#### PSoC<sup>®</sup> Solutions

[PSoC 1](#) | [PSoC 3](#) | [PSoC 4](#) | [PSoC 5LP](#) | [PSoC 6 MCU](#)

#### Cypress Developer Community

[Community](#) | [Projects](#) | [Video](#) | [Blogs](#) | [Training](#) | [Components](#)

#### Technical Support

[cypress.com/support](http://cypress.com/support)

© Cypress Semiconductor Corporation, 2007–2019. This document is the property of Cypress Semiconductor Corporation and its subsidiaries ("Cypress"). This document, including any software or firmware included or referenced in this document ("Software"), is owned by Cypress under the intellectual property laws and treaties of the United States and other countries worldwide. Cypress reserves all rights under such laws and treaties and does not, except as specifically stated in this paragraph, grant any license under its patents, copyrights, trademarks, or other intellectual property rights. If the Software is not accompanied by a license agreement and you do not otherwise have a written agreement with Cypress governing the use of the Software, then Cypress hereby grants you a personal, non-exclusive, nontransferable license (without the right to sublicense) (1) under its copyright rights in the Software (a) for Software provided in source code form, to modify and reproduce the Software solely for use with Cypress hardware products, only internally within your organization, and (b) to distribute the Software in binary code form externally to end users (either directly or indirectly through resellers and distributors), solely for use on Cypress hardware product units, and (2) under those claims of Cypress's patents that are infringed by the Software (as provided by Cypress, unmodified) to make, use, distribute, and import the Software solely for use with Cypress hardware products. Any other use, reproduction, modification, translation, or compilation of the Software is prohibited.

TO THE EXTENT PERMITTED BY APPLICABLE LAW, CYPRESS MAKES NO WARRANTY OF ANY KIND, EXPRESS OR IMPLIED, WITH REGARD TO THIS DOCUMENT OR ANY SOFTWARE OR ACCOMPANYING HARDWARE, INCLUDING, BUT NOT LIMITED TO, THE IMPLIED WARRANTIES OF MERCHANTABILITY AND FITNESS FOR A PARTICULAR PURPOSE. No computing device can be absolutely secure. Therefore, despite security measures implemented in Cypress hardware or software products, Cypress shall have no liability arising out of any security breach, such as unauthorized access to or use of a Cypress product. CYPRESS DOES NOT REPRESENT, WARRANT, OR GUARANTEE THAT CYPRESS PRODUCTS, OR SYSTEMS CREATED USING CYPRESS PRODUCTS, WILL BE FREE FROM CORRUPTION, ATTACK, VIRUSES, INTERFERENCE, HACKING, DATA LOSS OR THEFT, OR OTHER SECURITY INTRUSION (collectively, "Security Breach"). Cypress disclaims any liability relating to any Security Breach, and you shall and hereby do release Cypress from any claim, damage, or other liability arising from any Security Breach. In addition, the products described in these materials may contain design defects or errors known as errata which may cause the product to deviate from published specifications. To the extent permitted by applicable law, Cypress reserves the right to make changes to this document without further notice. Cypress does not assume any liability arising out of the application or use of any product or circuit described in this document. Any information provided in this document, including any sample design information or programming code, is provided only for reference purposes. It is the responsibility of the user of this document to properly design, program, and test the functionality and safety of any application made of this information and any resulting product. "High-Risk Device" means any device or system whose failure could cause personal injury, death, or property damage. Examples of High-Risk Devices are weapons, nuclear installations, surgical implants, and other medical devices. "Critical Component" means any component of a High-Risk Device whose failure to perform can be reasonably expected to cause, directly or indirectly, the failure of the High-Risk Device, or to affect its safety or effectiveness. Cypress is not liable, in whole or in part, and you shall and hereby do release Cypress from any claim, damage, or other liability arising from any use of a Cypress product as a Critical Component in a High-Risk Device. You shall indemnify and hold Cypress, its directors, officers, employees, agents, affiliates, distributors, and assigns harmless from and against all claims, costs, damages, and expenses, arising out of any claim, including claims for product liability, personal injury or death, or property damage arising from any use of a Cypress product as a Critical Component in a High-Risk Device. Cypress products are not intended or authorized for use as a Critical Component in any High-Risk Device except to the limited extent that (i) Cypress's published data sheet for the product explicitly states Cypress has qualified the product for use in a specific High-Risk Device, or (ii) Cypress has given you advance written authorization to use the product as a Critical Component in the specific High-Risk Device and you have signed a separate indemnification agreement.

Cypress, the Cypress logo, Spansion, the Spansion logo, and combinations thereof, WICED, PSoC, CapSense, EZ-USB, F-RAM, and Traveo are trademarks or registered trademarks of Cypress in the United States and other countries. For a more complete list of Cypress trademarks, visit [cypress.com](http://cypress.com). Other names and brands may be claimed as property of their respective owners.

## Looking for pricing, stock, or lifecycle information?

Click below to explore more details on WIN SOURCE:

 [View CY62138FLL-45SXI on WIN SOURCE](#)

 [Infineon Technologies](#) Information

## Optimize Your Supply Chain with WIN SOURCE Solutions

-  Global Sourcing Solution
-  Obsolete Management
-  Cost Control Management
-  Shortage Management
-  Alternative Solution
-  Excess Inventory Management