



**THE DATASHEET OF
AD7237AAN**



AD7237A/AD7247A

FEATURES

Complete Dual 12-Bit DAC Comprising
 Two 12-Bit CMOS DACs
 On-Chip Voltage Reference
 Output Amplifiers
 Reference Buffer Amplifiers
Improved AD7237/AD7247:
 12 V to 15 V Operation
 Faster Interface –30 ns typ Data Setup Time
Parallel Loading Structure: AD7247A
(8+4) Loading Structure: AD7237A
 Single or Dual Supply Operation
 Low Power—165 mW typ in Single Supply

GENERAL DESCRIPTION

The AD7237A/AD7247A is an enhanced version of the industry standard AD7237/AD7247. Improvements include operation from 12 V to 15 V supplies, faster interface times and better reference variations with V_{DD} . Additional features include faster settling times.

The AD7237A/AD7247A is a complete, dual, 12-bit, voltage output digital-to-analog converter with output amplifiers and Zener voltage reference on a monolithic CMOS chip. No external user trims are required to achieve full specified performance.

Both parts are microprocessor compatible, with high speed data latches and interface logic. The AD7247A accepts 12-bit parallel data which is loaded into the respective DAC latch using the \overline{WR} input and a separate Chip Select input for each DAC. The AD7237A has a double buffered interface structure and an 8-bit wide data bus with data loaded to the respective input latch in two write operations. An asynchronous \overline{LDAC} signal on the AD7237A updates the DAC latches and analog outputs.

A REF OUT/REF IN function is provided which allows either the on-chip 5 V reference or an external reference to be used as a reference voltage for the part. For single supply operation, two output ranges of 0 V to +5 V and 0 V to +10 V are available, while these two ranges plus an additional ± 5 V range are available with dual supplies. The output amplifiers are capable of developing +10 V across a 2 k Ω load to GND.

The AD7237A/AD7247A is fabricated in Linear Compatible CMOS (LC²MOS), an advanced, mixed technology process that combines precision bipolar circuits with low power CMOS logic. Both parts are available in a 24-pin, 0.3" wide plastic and hermetic dual-in-line package (DIP) and are also packaged in a 24-lead small outline (SOIC) package.

REV. 0

Information furnished by Analog Devices is believed to be accurate and reliable. However, no responsibility is assumed by Analog Devices for its use, nor for any infringements of patents or other rights of third parties which may result from its use. No license is granted by implication or otherwise under any patent or patent rights of Analog Devices.

FUNCTIONAL BLOCK DIAGRAMS

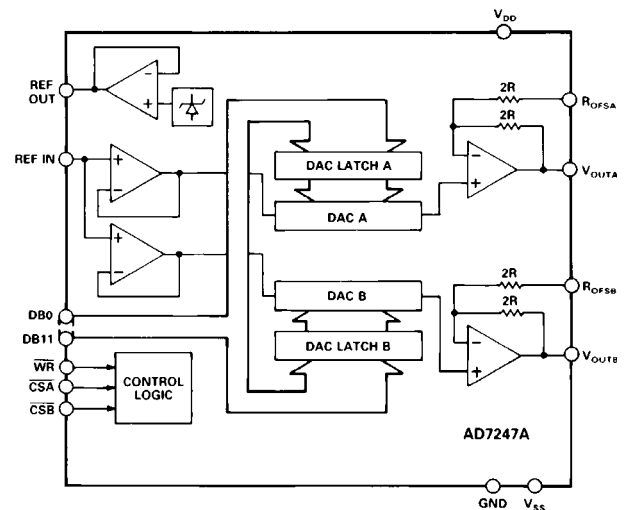
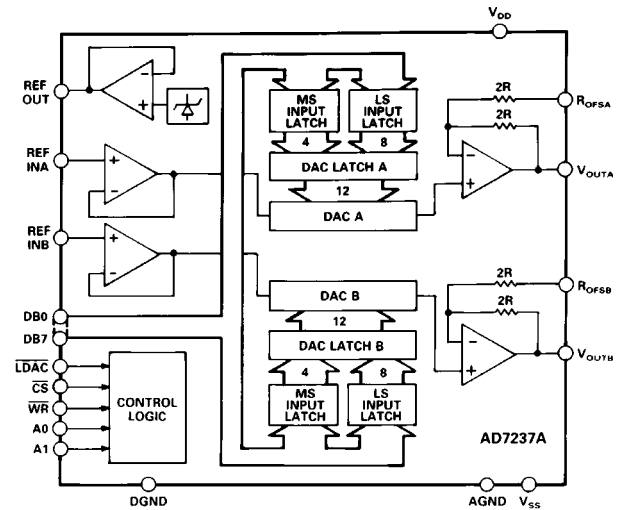

PRODUCT HIGHLIGHTS

1. The AD7237A/AD7247A is a dual 12-bit DACPORT[®] on a single chip. This single chip design and small package size offer considerable space saving and increased reliability over multichip designs.
2. The improved interface times of the parts allow easy, direct interfacing to most modern microprocessors, whether they have 8-bit or 16-bit data bus structures.
3. The AD7237A/AD7247A features a wide power supply range allowing operation from 12 V supplies.

DACPORT is a registered trademark of Analog Devices, Inc.

AD7237A/AD7247A—SPECIFICATIONS

($V_{DD} = +12\text{ V to }+15\text{ V}$, $V_{SS} = 0\text{ V or }-12\text{ V to }-15\text{ V}$,¹ $AGND = DGND = 0\text{ V [AD7237A]}$, $GND = 0\text{ V [AD7247A]}$, $REF\ IN = +5\text{ V}$, $R_L = 2\text{ k}\Omega$, $C_L = 100\text{ pF}$. All specifications T_{MIN} to T_{MAX} unless otherwise noted.)

Parameter	A ²	B ²	T ²	Units	Test Conditions/Comments
STATIC PERFORMANCE					
Resolution	12	12	12	Bits	
Relative Accuracy ³	± 1	$\pm 1/2$	$\pm 1/2$	LSB max	
Differential Nonlinearity ³	± 0.9	± 0.9	± 0.9	LSB max	Guaranteed Monotonic
Unipolar Offset Error ³	± 3	± 3	± 4	LSB max	$V_{SS} = 0\text{ V or }-12\text{ V to }-15\text{ V}$ ⁴ . DAC Latch Contents All 0s
Bipolar Zero Error ³	± 6	± 4	± 6	LSB max	$V_{SS} = -12\text{ V to }-15\text{ V}$ ⁴ . DAC Latch Contents 1000 0000 0000
Full-Scale Error ^{3,5}	± 5	± 5	± 6	LSB max	
Full-Scale Mismatch ⁵	± 1	± 1	± 1	LSB typ	
REFERENCE OUTPUT					
REF OUT	4.97/5.03	4.97/5.03	4.95/5.05	V min/max	
Reference Temperature Coefficient	± 25	± 25	± 25	ppm/ $^{\circ}\text{C}$ typ	
Reference Load Change ($\Delta\text{REF OUT vs. } \Delta\text{I}$)	-1	-1	-1	mV max	Reference Load Current Change (0-100 μA)
REFERENCE INPUT					
Reference Input Range	4.75/5.25	4.75/5.25	4.75/5.25	V min/max	$5\text{ V} \pm 5\%$
Input Current ⁶	± 5	± 5	± 5	μA max	
DIGITAL INPUTS					
Input High Voltage, V_{INH}	2.4	2.4	2.4	V min	
Input Low Voltage, V_{INL}	0.8	0.8	0.8	V max	
Input Current					
I_{IN} (Data Inputs)	± 10	± 10	± 10	μA max	$V_{IN} = 0\text{ V to }V_{DD}$
Input Capacitance ⁶	8	8	8	pF max	
ANALOG OUTPUTS					
Output Range Resistors	15/30	15/30	15/30	k Ω min/max	
Output Voltage Ranges ⁷	+5, +10	+5, +10	+5, +10, ± 5	V	Single Supply; ($V_{SS} = 0\text{ V}$)
Output Voltage Ranges ⁷	+5, +10, ± 5	+5, +10, ± 5	+5, +10, ± 5	V	Dual Supply; ($V_{SS} = -12\text{ V to }-15\text{ V}$ ⁴)
DC Output Impedance	0.5	0.5	0.5	Ω typ	
AC CHARACTERISTICS⁶					
Voltage Output Settling Time					Settling Time to Within $\pm 1/2$ LSB of Final Value
Positive Full-Scale Change	8	8	10	μs max	DAC Latch all 0s to all 1s. Typically 5 μs
Negative Full-Scale Change	8	8	10	μs max	DAC Latch all 1s to all 0s. Typically 5 μs
Digital-to-Analog Glitch Impulse ³	30	30	30	nV secs typ	$V_{SS} = -12\text{ V to }-15\text{ V}$ ⁴ .
Digital Feedthrough ³	10	10	10	nV secs typ	DAC Latch Contents Toggled Between all 0s and all 1s
Digital Crosstalk ³	30	30	30	nV secs typ	
POWER REQUIREMENTS					
V_{DD}	+10.8/+16.5	+11.4/+15.75	+11.4/+15.75	V min/max	For Specified Performance Unless Otherwise Stated
V_{SS}	-10.8/-16.5	-11.4/-15.75	-11.4/-15.75	V min/max	For Specified Performance Unless Otherwise Stated
I_{DD}	15	15	15	mA max	Output Unloaded. Typically 10 mA
I_{SS} (Dual Supplies)	5	5	5	mA max	Output Unloaded. Typically 3 mA

NOTES

¹Power Supply tolerance is $\pm 10\%$ for A version and $\pm 5\%$ for B and T versions.

²Temperature ranges are as follows: A, B Versions, -40°C to $+85^{\circ}\text{C}$; T Version, -55°C to $+125^{\circ}\text{C}$.

³See Terminology.

⁴With appropriate power supply tolerances.

⁵Measured with respect to REF IN and includes unipolar/bipolar offset error.

⁶Sample tested @ $+25^{\circ}\text{C}$ to ensure compliance.

⁷0 V to +10 V range is only available with $V_{DD} \geq 14.25\text{ V}$.

Specifications subject to change without notice.

TIMING CHARACTERISTICS^{1, 2} ($V_{DD} = +12\text{ V to } +15\text{ V}$,³ $V_{SS} = 0\text{ V or } -12\text{ V to } -15\text{ V}$,³ $AGND = DGND = 0\text{ V}$ [AD7237A], $GND = 0\text{ V}$ [AD7247A])

Parameter	Limit at T_{MIN} , T_{MAX} (A, B Versions)	Limit at T_{MIN} , T_{MAX} (T Version)	Units	Conditions/Comments
t_1	0	0	ns min	\overline{CS} to \overline{WR} Setup Time
t_2	0	0	ns min	\overline{CS} to \overline{WR} Hold Time
t_3	80	100	ns min	\overline{WR} Pulse Width
t_4	80	80	ns min	Data Valid to \overline{WR} Setup Time
t_5^4	10	10	ns min	Data Valid to \overline{WR} Hold Time
t_6	0	0	ns min	Address to \overline{WR} Setup Time
t_7	0	0	ns min	Address to \overline{WR} Hold Time
t_8^5	80	100	ns min	LDAC Pulse Width

NOTES

¹Sample tested at +25°C to ensure compliance. All input signals are specified with $t_r = t_f = 5\text{ ns}$ (10% to 90% of 5 V) and timed from a voltage level of 1.6 V.

²See Figures 5 and 7.

³Power Supply tolerance is $\pm 10\%$ for A version and $\pm 5\%$ for B and T versions.

⁴If $0\text{ ns} < t_2 < 10\text{ ns}$, add t_2 to t_5 . If $t_2 \geq 10\text{ ns}$, add 10 ns to t_5 .

⁵AD7237A only.

ABSOLUTE MAXIMUM RATINGS¹

($T_A = +25^\circ\text{C}$ unless otherwise noted)

V_{DD} to GND (AD7247A) -0.3 V to +17 V

V_{DD} to AGND, DGND (AD7237A) -0.3 V to +17 V

V_{DD} to V_{SS} -0.3 V to +34 V

AGND to DGND (AD7237A) -0.3 V, $V_{DD} + 0.3\text{ V}$

V_{OUTA} ,² V_{OUTB} to AGND (GND) $V_{SS} - 0.3\text{ V to } V_{DD} + 0.3\text{ V}$

REF OUT to AGND (GND) 0 V to V_{DD}

REF IN to AGND (GND) -0.3 V to $V_{DD} + 0.3\text{ V}$

Digital Inputs to DGND (GND) -0.3 V to $V_{DD} + 0.3\text{ V}$

Operating Temperature Range

Industrial (A, B Versions) -40°C to +85°C

Extended (T Version) -55°C to +125°C

Storage Temperature Range -65°C to +150°C

Lead Temperature (Soldering, 10 secs) +300°C

Power Dissipation (Any Package) to +75°C 1000 mW

Derates above +75°C by 10 mW/°C

NOTES

¹Stresses above those listed under “Absolute Maximum Ratings” may cause permanent damage to the device. This is a stress rating only and functional operation of the device at these or any other conditions above those listed in the operational sections of this specification is not implied. Exposure to absolute maximum rating conditions for extended periods may affect device reliability.

²Short-circuit current is typically 80 mA. The outputs may be shorted to voltages in this range provided the power dissipation of the package is not exceeded.

ORDERING GUIDE

Model ¹	Temperature Range	Relative Accuracy (LSB)	Package Option ²
AD7237AAN	-40°C to +85°C	$\pm 1\text{ max}$	N-24
AD7237ABN	-40°C to +85°C	$\pm 1/2\text{ max}$	N-24
AD7237AAR	-40°C to +85°C	$\pm 1\text{ max}$	R-24
AD7237ABR	-40°C to +85°C	$\pm 1/2\text{ max}$	R-24
AD7237ATQ	-55°C to +125°C	$\pm 1/2\text{ max}$	Q-24
AD7247AAN	-40°C to +85°C	$\pm 1\text{ max}$	N-24
AD7247ABN	-40°C to +85°C	$\pm 1/2\text{ max}$	N-24
AD7247AAR	-40°C to +85°C	$\pm 1\text{ max}$	R-24
AD7247ABR	-40°C to +85°C	$\pm 1/2\text{ max}$	R-24
AD7247ATQ	-55°C to +125°C	$\pm 1/2\text{ max}$	Q-24

NOTES

¹To order MIL-STD-883, Class B processed parts, add /883B to part number.

Contact local sales office for military data sheet and availability.

²N = Plastic DIP; Q = Cerdip; R = Small Outline (SOIC).

CAUTION

ESD (electrostatic discharge) sensitive device. Electrostatic charges as high as 4000 V readily accumulate on the human body and test equipment and can discharge without detection. Although the AD7237A/AD7247A features proprietary ESD protection circuitry, permanent damage may occur on devices subjected to high energy electrostatic discharges. Therefore, proper ESD precautions are recommended to avoid performance degradation or loss of functionality.



AD7237A/AD7247A

AD7237A PIN FUNCTION DESCRIPTION (DIP PIN NUMBERS)

Pin	Mnemonic	Description
1	REF INA	Voltage Reference Input for DAC A. The reference voltage for DAC A is applied to this pin. It is internally buffered before being applied to the DAC. The nominal reference voltage for correct operation of the AD7237A is 5 V.
2	REF OUT	Voltage Reference Output. The internal 5 V analog reference is provided at this pin. To operate the part with internal reference, REF OUT should be connected to REF INA, REF INB.
3	REF INB	Voltage Reference Input for DAC B. The reference voltage for DAC B is applied to this pin. It is internally buffered before being applied to the DAC. The nominal reference voltage for correct operation of the AD7237A is 5 V.
4	R _{OFFSB}	Output Offset Resistor for DAC B. This input configures the output ranges for DAC B. It is connected to V _{OUTB} for the +5 V range, to AGND for the +10 V range and to REF INB for the ±5 V range.
5	V _{OUTB}	Analog Output Voltage from DAC B. This is the buffer amplifier output voltage. Three different output voltage ranges can be chosen: 0 V to +5 V, 0 V to +10 V and ±5 V. The amplifier is capable of developing +10 V across a 2 kΩ resistor to GND.
6	AGND	Analog Ground. Ground reference for DACs, reference and output buffer amplifiers.
7	DB7	Data Bit 7.
8-10	DB6-DB4	Data Bit 6 to Data Bit 4.
11	DB3	Data Bit 3/Data Bit 11 (MSB).
12	DGND	Digital Ground. Ground reference for digital circuitry.
13	DB2	Data Bit 2/Data Bit 10.
14	DB1	Data Bit 1/Data Bit 9.
15	DB0	Data Bit 0 (LSB)/Data Bit 8.
16	A0	Address Input. Least significant address input for input latches. A0 and A1 select which of the four input latches data is written to (see Table II).
17	A1	Address Input. Most significant address input for input latches.
18	\overline{CS}	Chip Select. Active low logic input. The device is selected when this input is active.
19	\overline{WR}	Write Input. \overline{WR} is an active low logic input which is used in conjunction with \overline{CS} , A0 and A1 to write data to the input latches.
20	\overline{LDAC}	Load DAC. Logic input. A new word is loaded into the DAC latches from the respective input latches on the falling edge of this signal.
21	V _{DD}	Positive Supply (+12 V to +15 V).
22	V _{OUTA}	Analog Output Voltage from DAC A. This is the buffer amplifier output voltage. Three different output voltage ranges can be chosen: 0 V to +5 V, 0 V to +10 V and ±5 V. The amplifier is capable of developing +10 V across a 2 kΩ resistor to GND.
23	V _{SS}	Negative Supply (0 V or -12 V to -15 V).
24	R _{OFFSA}	Output Offset Resistor for DAC A. This input configures the output ranges for DAC A. It is connected to V _{OUTA} for the +5 V range, to AGND for the +10 V range and to REF INA for the ±5 V range.

AD7247A PIN FUNCTION DESCRIPTION (DIP PIN NUMBERS)

Pin	Mnemonic	Description
1	REF OUT	Voltage Reference Output. The internal 5 V analog reference is provided at this pin. To operate the part with internal reference, REF OUT should be connected to REF IN.
2	R _{OFBS}	Output Offset Resistor for DAC B. This input configures the output ranges for DAC B. It is connected to V _{OUTB} for the +5 V range, to GND for the +10 V range and to REF IN for the ±5 V range.
3	V _{OUTB}	Analog Output Voltage from DAC B. This is the buffer amplifier output voltage. Three different output voltage ranges can be chosen: 0 V to +5 V, 0 V to +10 V and ±5 V. The amplifier is capable of developing +10 V across a 2 kΩ resistor to GND.
4	DB11	Data Bit 11 (MSB).
5	DB10	Data Bit 10.
6	GND	Ground. Ground reference for all on-chip circuitry.
7–15	DB9-DB1	Data Bit 9 to Data Bit 1.
16	DB0	Data Bit 0 (LSB).
17	$\overline{\text{CSB}}$	Chip Select Input for DAC B. Active low logic input. DAC B is selected when this input is active.
18	$\overline{\text{CSA}}$	Chip Select Input for DAC A. Active low logic input. DAC A is selected when this input is active.
19	$\overline{\text{WR}}$	Write Input. $\overline{\text{WR}}$ is an active low logic input which is used in conjunction with $\overline{\text{CSA}}$ and $\overline{\text{CSB}}$ to write data to the DAC latches.
20	V _{DD}	Positive Supply (+12 V to +15 V).
21	V _{OUTA}	Analog Output Voltage from DAC A. This is the buffer amplifier output voltage. Three different output voltage ranges can be chosen: 0 V to +5 V, 0 V to +10 V and ±5 V. The amplifier is capable of developing +10 V across a 2 kΩ resistor to GND.
22	V _{SS}	Negative Supply (0 V or -12 V to -15 V).
23	R _{OFSA}	Output Offset Resistor for DAC A. This input configures the output ranges for DAC A. It is connected to V _{OUTA} for the +5 V range, to GND for the +10 V range and to REF IN for the ±5 V range.
24	REF IN	Voltage Reference Input. The common reference voltage for both DACs is applied to this pin. It is internally buffered before being applied to both DACs. The nominal reference voltage for correct operation of the AD7247A is 5 V.

AD7237A PIN CONFIGURATION
DIP and SOIC

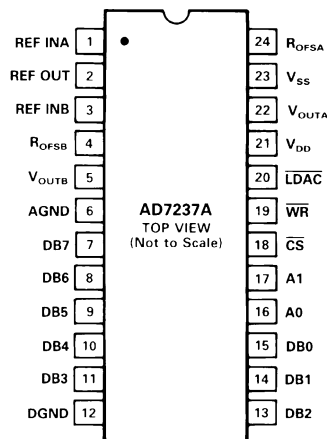

AD7247A PIN CONFIGURATION
DIP and SOIC

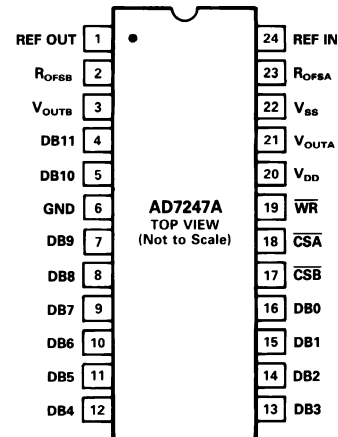

AD7237A/AD7247A

TERMINOLOGY

RELATIVE ACCURACY (LINEARITY)

Relative Accuracy, or endpoint linearity, is a measure of the maximum deviation of the DAC transfer function from a straight line passing through the endpoints of the transfer function. It is measured after allowing for zero and full-scale errors and is expressed in LSBs or as a percentage of full-scale reading.

DIFFERENTIAL NONLINEARITY

Differential Nonlinearity is the difference between the measured change and the ideal 1 LSB change between any two adjacent codes. A specified differential nonlinearity of ± 1 LSB or less over the operating temperature range ensures monotonicity.

SINGLE SUPPLY LINEARITY AND GAIN ERROR

The output amplifiers of the AD7237A/AD7247A can have true negative offsets even when the part is operated from a single +12 V to +15 V supply. However, because the negative supply rail (V_{SS}) is 0 V, the output cannot actually go negative. Instead, when the output offset voltage is negative, the output voltage sits at 0 V, resulting in the transfer function shown in Figure 1. This “knee” is an offset effect, not a linearity error, and the transfer function would have followed the dotted line if the output voltage could have gone negative.

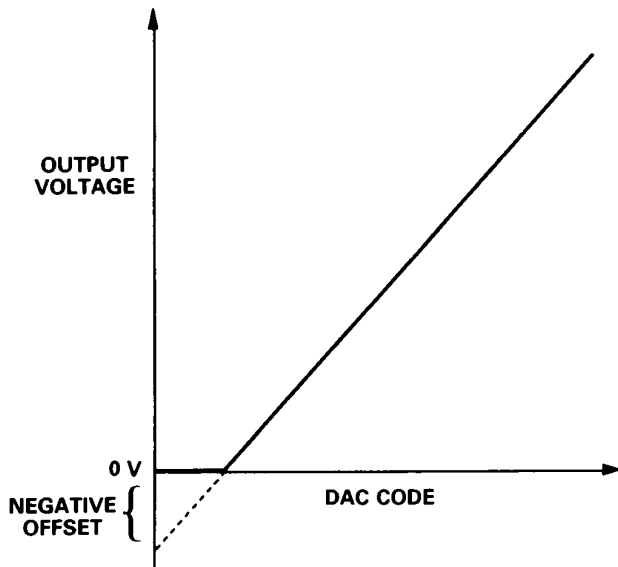

Figure 1. Effect of Negative Offset (Single Supply)

Normally, linearity is measured between zero (all 0s input code) and full scale (all 1s input code) after offset and full scale have been adjusted out or allowed for, but this is not possible in single supply operation if the offset is negative, due to the knee in the transfer function. Instead, linearity of the AD7237A/AD7247A in the unipolar mode is measured between full scale and the lowest code which is guaranteed to produce a positive output voltage. This code is calculated from the maximum specification for negative offset, i.e., linearity is measured between Codes 3 and 4095.

UNIPOLAR OFFSET ERROR

Unipolar Offset Error is the measured output voltage from V_{OUTA} or V_{OUTB} with all zeros loaded into the DAC latches when the DACs are configured for unipolar output. It is a combination of the offset errors of the DAC and output amplifier.

BIPOLAR ZERO ERROR

Bipolar Zero Error is the voltage measured at V_{OUTA} or V_{OUTB} when the DAC is connected in the bipolar mode and loaded with code 2048. It is due to a combination of offset errors in the DAC, amplifier offset and mismatch in the application resistors around the amplifier.

FULL-SCALE ERROR

Full-Scale Error is a measure of the output error when the amplifier output is at full scale (for the bipolar output range full scale is either positive or negative full scale). It is measured with respect to the reference input voltage and includes the offset errors.

DIGITAL FEEDTHROUGH

Digital Feedthrough is the glitch impulse injected for the digital inputs to the analog output when the data inputs change state, but the data in the DAC latches is not changed.

For the AD7237A it is measured with \overline{LDAC} held high. For the AD7247A it is measured with \overline{CSA} and \overline{CSB} held high.

DIGITAL CROSSTALK

Digital crosstalk is the glitch impulse transferred to the output of one converter due to a change in digital code to the DAC latch of the other converter. It is specified in nV secs.

DIGITAL-TO-ANALOG GLITCH IMPULSE

This is the voltage spike that appears at the output of the DAC when the digital code changes before the output settles to its final value. The energy in the glitch is specified in nV secs and is measured for a 1 LSB change around the major carry transition (0111 1111 1111 to 1000 0000 0000).

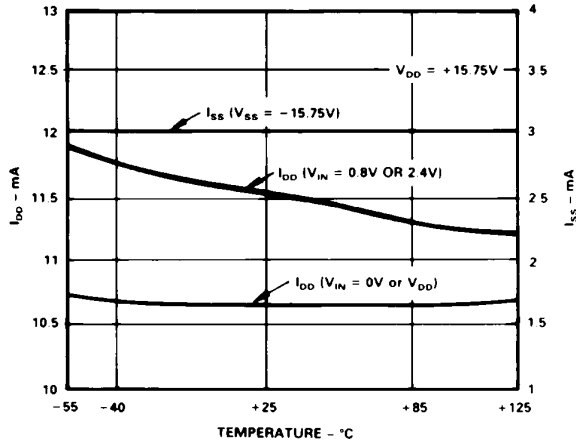

Power Supply Current vs. Temperature

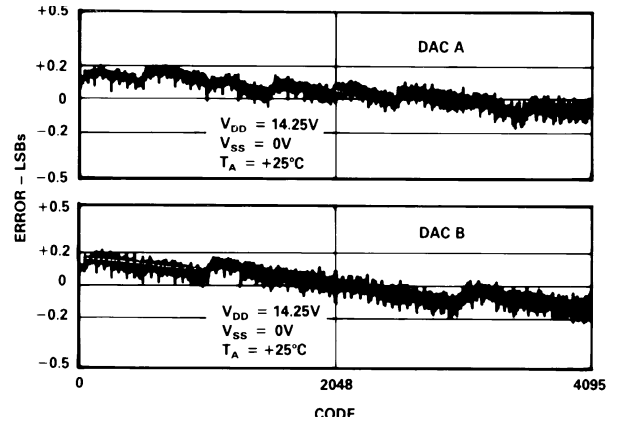

DAC-to-DAC Linearity Matching

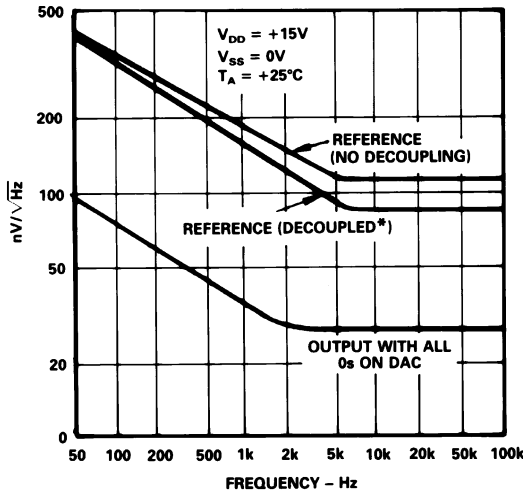

*REFERENCE DECOUPLING COMPONENTS ARE A 200Ω RESISTOR IN SERIES WITH A PARALLEL COMBINATION OF 10μF AND 0.1μF TO GND.

Noise Spectral Density vs. Frequency

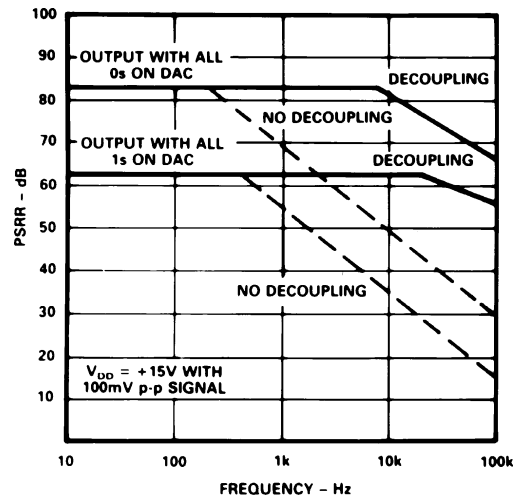

*POWER SUPPLY DECOUPLING CAPACITORS ARE 10μF AND 0.1μF.

Power Supply Rejection Ratio vs. Frequency

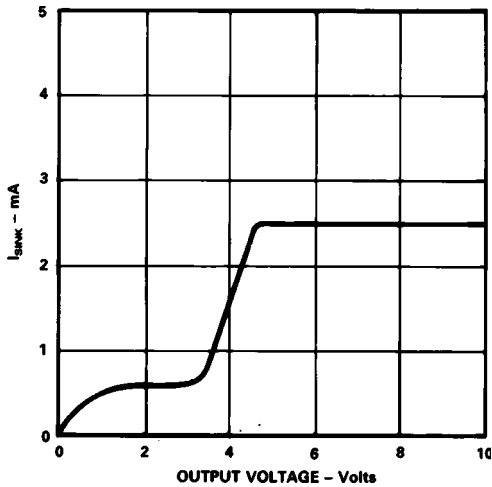

Single Supply Sink Current vs. Output Voltage

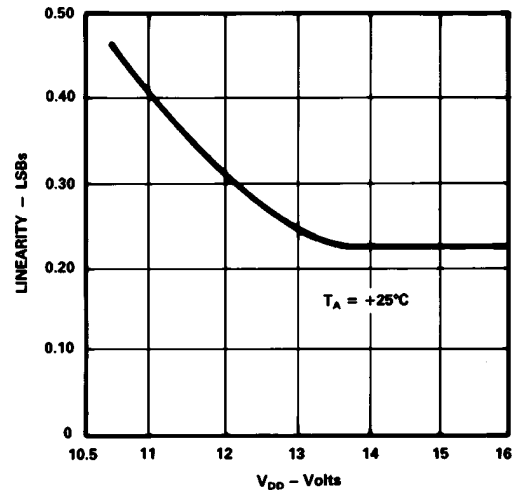

Linearity vs. Power Supply Voltage

AD7237A/AD7247A

CIRCUIT INFORMATION

D/A Section

The AD7237A/AD7247A contains two 12-bit voltage-mode D/A converters consisting of highly stable thin film resistors and high speed NMOS single-pole, double-throw switches. The output voltage from the converters has the same polarity as the reference voltage, REF IN, allowing single supply operation. The simplified circuit diagram for one of the D/A converters is shown in Figure 2.

The REF IN voltage is internally buffered by a unity gain amplifier before being applied to the D/A converters. The D/A converters are configured and scaled for a 5 V reference and the device is tested with 5 V applied to REF IN.

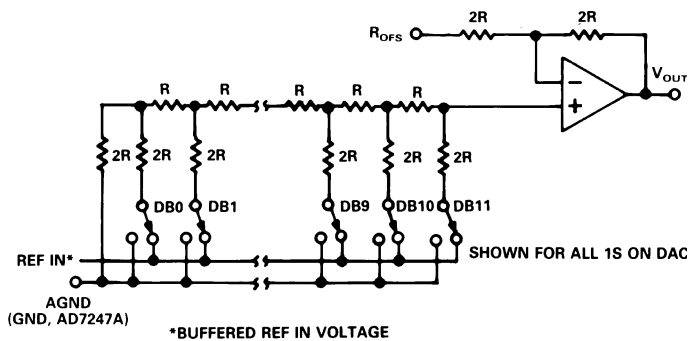

Figure 2. D/A Simplified Circuit Diagram

Internal Reference

The AD7237A/AD7247A has an on-chip temperature compensated buried Zener reference (see Figure 3) which is factory trimmed to 5 V \pm 30 mV (\pm 50 mV for T Version). The reference voltage is provided at the REF OUT pin. This reference can be used to provide the reference voltage for the D/A converter (by connecting the REF OUT pin to the REF IN pin) and the offset voltage for bipolar outputs (by connecting REF OUT to R_{OFS}).

The reference voltage can also be used as a reference for other components and is capable of providing up to 500 μ A to an external load. The maximum recommended capacitance on REF OUT for normal operation is 50 pF. If the reference is required for external use, it should be decoupled to AGND (GND) with a 200 Ω resistor in series with parallel combination of a 10 μ F tantalum capacitor and a 0.1 μ F ceramic capacitor.

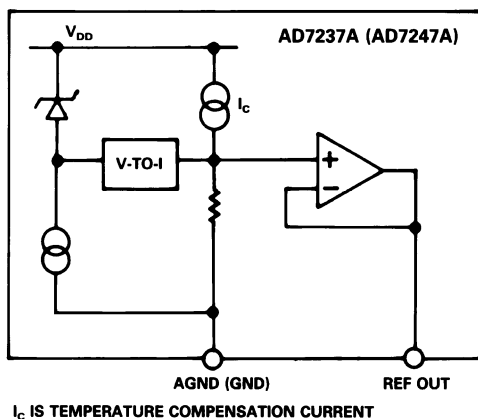

Figure 3. Internal Reference

External Reference

In some applications, the user may require a system reference or some other external reference to drive the AD7237A/AD7247A reference input. References such as the AD586 5 V reference provide the ideal external reference source for the AD7237A/AD7247A (see Figure 9).

Op Amp Section

The output of the voltage-mode D/A converter is buffered by a noninverting CMOS amplifier. The R_{OFS} input allows different output voltage ranges to be selected. The buffer amplifier is capable of developing +10 V across a 2 k Ω load to GND. The output amplifier can be operated from a single +12 V to +15 V supply by tying V_{SS} = 0 V. The amplifier can also be operated from dual supplies (\pm 12 V to \pm 15 V) to allow a bipolar output range of -5 V to +5 V. The advantages of having dual supplies for the unipolar output ranges are faster settling time to voltages near 0 V, full sink capability of 2.5 mA maintained over the entire output range and the elimination of the effects of negative offsets on the transfer characteristic (outlined previously). A plot of the single supply output sink capability of the amplifier is shown in the Typical Performance Graphs section.

INTERFACE LOGIC INFORMATION—AD7247A

Table I shows the truth table for AD7247A operation. The part contains a single, parallel 12-bit latch for each DAC. It can be treated as two independent DACs, each with its own $\overline{\text{CS}}$ input and a common $\overline{\text{WR}}$ input. $\overline{\text{CSA}}$ and $\overline{\text{WR}}$ control the loading of data to the DAC A latch while $\overline{\text{CSB}}$ and $\overline{\text{WR}}$ control the loading of the DAC B latch. If $\overline{\text{CSA}}$ and $\overline{\text{CSB}}$ are both low, with $\overline{\text{WR}}$ low, the same data will be written to both DAC latches. All control signals are level triggered and therefore either or both latches can be made transparent. Input data is latched to the respective latch on the rising edge of $\overline{\text{WR}}$. Figure 4 shows the input control logic for the AD7247A, while the write cycle timing diagram for the part is shown in Figure 5.

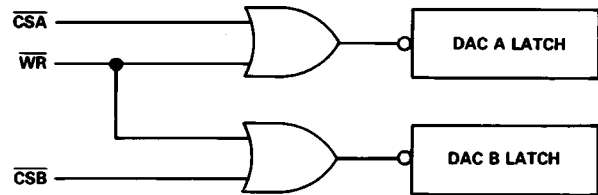

Figure 4. AD7247A Input Control Logic

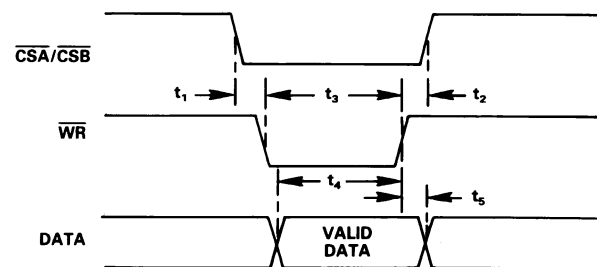

Figure 5. AD7247A Write Cycle Timing Diagram

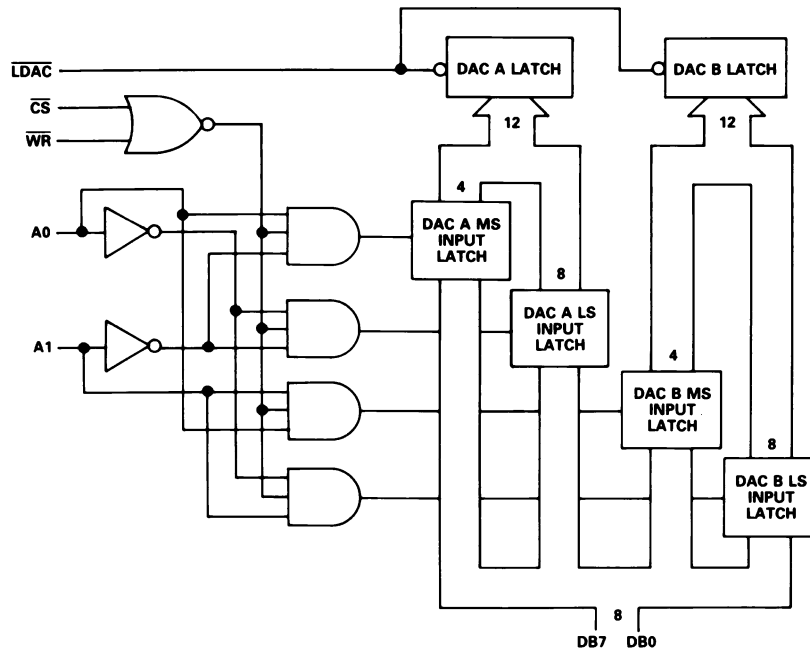

Figure 6. AD7237A Input Control Logic

Table I. AD7247A Truth Table

CSA	CSB	WR	Function
X	X	1	No Data Transfer
1	1	X	No Data Transfer
0	1	0	DAC A Latch Transparent
1	0	0	DAC B Latch Transparent
0	0	0	Both DAC Latches Transparent

X = Don't Care

INTERFACE LOGIC INFORMATION—AD7237A

The input loading structure on the AD7237A is configured for interfacing to microprocessors with an 8-bit-wide data bus. The part contains two 12-bit latches per DAC—an input latch and a DAC latch. Each input latch is further subdivided into a least significant 8-bit latch and a most significant 4-bit latch. Only the data held in the DAC latches determines the outputs from the part. The input control logic for the AD7237A is shown in Figure 6, while the write cycle timing diagram is shown in Figure 7.

$\overline{\text{CS}}$, $\overline{\text{WR}}$, A0 and A1 control the loading of data to the input latches. The eight data inputs accept right-justified data. Data can be loaded to the input latches in any sequence. Provided that $\overline{\text{LDAC}}$ is held high, there is no analog output change as a result of loading data to the input latches. Address lines A0 and A1 determine which latch data is loaded to when $\overline{\text{CS}}$ and $\overline{\text{WR}}$ are low. The selection of the input latches is shown in the truth table for AD7237A operation in Table II.

The $\overline{\text{LDAC}}$ input controls the transfer of 12-bit data from the input latches to the DAC latches. Both DAC latches, and hence both analog outputs, are updated at the same time. The $\overline{\text{LDAC}}$ signal is level triggered, and data is latched into the DAC latch on the rising edge of $\overline{\text{LDAC}}$. The $\overline{\text{LDAC}}$ input is asynchronous and independent of $\overline{\text{WR}}$. This is useful in many applications especially in the simultaneous updating of multiple AD7237As.

Table II. AD7237A Truth Table

CS	WR	A1	A0	LDAC	Function
1	X	X	X	1	No Data Transfer
X	1	X	X	1	No Data Transfer
0	0	0	0	1	DAC A LS Input Latch Transparent
0	0	0	1	1	DAC A MS Input Latch Transparent
0	0	1	0	1	DAC B LS Input Latch Transparent
0	0	1	1	1	DAC B MS Input Latch Transparent
1	1	X	X	0	DAC A and DAC B DAC Latches Updated Simultaneously from the Respective Input Latches

X = Don't Care.

However, care must be taken while exercising $\overline{\text{LDAC}}$ during a write cycle. If an $\overline{\text{LDAC}}$ operation overlaps a $\overline{\text{CS}}$ and $\overline{\text{WR}}$ operation, there is a possibility of invalid data being latched to the output. To avoid this, $\overline{\text{LDAC}}$ must remain low after $\overline{\text{CS}}$ or $\overline{\text{WR}}$ return high for a period equal to or greater than t_8 , the minimum $\overline{\text{LDAC}}$ pulse width.

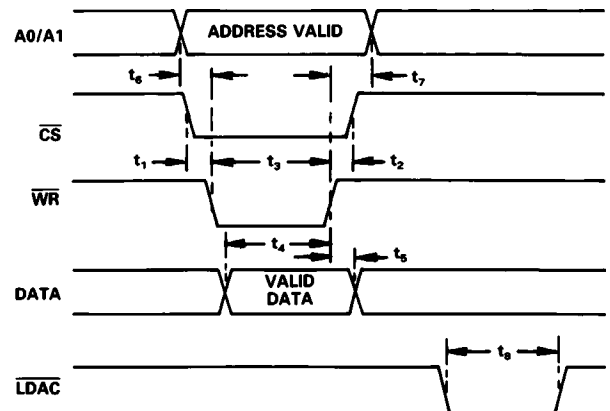

Figure 7. AD7237A Write Cycle Timing Diagram

AD7237A/AD7247A

APPLYING THE AD7237A/AD7247A

The internal scaling resistors provided on the AD7237A/AD7247A allow several output voltage ranges. The part can produce unipolar output ranges of 0 V to +5 V or 0 V to +10 V and a bipolar output range of ± 5 V. Connections for the various ranges are outlined below. Since each DAC has its own R_{OFS} input the two DACs on each part can be set up for different output ranges.

Unipolar (0 V to +10 V) Configuration

The first of the configurations provides an output voltage range of 0 V to +10 V. This is achieved by connecting the output offset resistor, R_{OFS_A} or R_{OFS_B} , to AGND (GND for AD7247A). In this configuration, the AD7237A/AD7247A can be operated from single or dual supplies. Figure 8 shows the connection diagram for unipolar operation for DAC A of the AD7237A, while the table for output voltage versus digital code in the DAC latch is shown in Table III. Similar connections apply to the AD7247A.

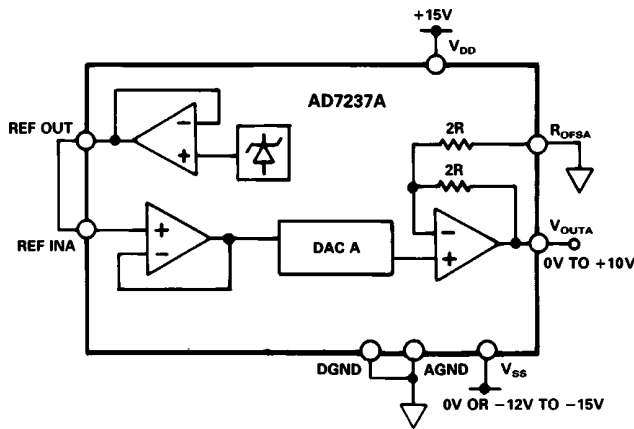

Figure 8. Unipolar (0 to +10 V) Configuration

Table III. Unipolar Code Table (0 to +10 V Range)

DAC Latch Contents		Analog Output, V_{OUT}
MSB	LSB	
1111	1111 1111	$+2 \cdot \text{REF IN}$ (4095/4096)
1000	0000 0001	$+2 \cdot \text{REF IN}$ (2049/4096)
1000	0000 0000	$+2 \cdot \text{REF IN}$ (2048/4096) = $+\text{REF IN}$
0111	1111 1111	$+2 \cdot \text{REF IN}$ (2047/4096)
0000	0000 0001	$+2 \cdot \text{REF IN}$ (1/4096)
0000	0000 0000	0 V

Note: 1 LSB = $\text{REF IN}/2048$.

Unipolar (0 V to +5 V) Configuration

The 0 V to +5 V output voltage range is achieved by tying R_{OFS_A} or R_{OFS_B} to V_{OUTA} or V_{OUTB} . Once again, the AD7237A/AD7247A can be operated single supply or from dual supplies. The table for output voltage versus digital code is as in Table III, with $2 \cdot \text{REF IN}$ replaced by REF IN . Note, for this range, $1 \text{ LSB} = \text{REF IN} \cdot (2^{-12}) = (\text{REF IN}/4096)$.

Bipolar Configuration

The bipolar configuration for the AD7237A/AD7247A, which gives an output range of -5 V to +5 V, is achieved by connecting R_{OFS_A} or R_{OFS_B} to REF IN . The AD7237A/AD7247A must be operated from dual supplies to achieve this output voltage range. Figure 9 shows the connection diagram for bipolar operation for DAC A of the AD7247A. An AD586 provides the reference voltage for the DAC but this could be provided by the on-chip reference by connecting REF OUT to REF IN . The code table for bipolar operation is shown in Table IV. Similar connections apply for the AD7237A.

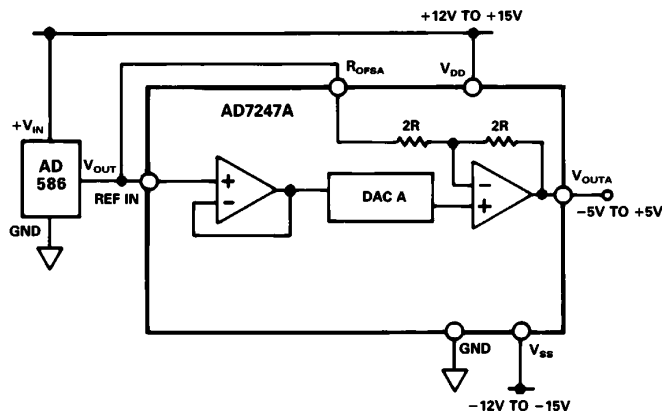

Figure 9. Bipolar Configuration

Table IV. Bipolar Code Table

DAC Latch Contents		Analog Output, V_{OUT}
MSB	LSB	
1111	1111 1111	$+\text{REF IN} \cdot (2047/2048)$
1000	0000 0001	$+\text{REF IN} \cdot (1/2048)$
1000	0000 0000	0 V
0111	1111 1111	$-\text{REF IN} \cdot (1/2048)$
0000	0000 0001	$-\text{REF IN} \cdot (2047/2048)$
0000	0000 0000	$-\text{REF IN} \cdot (2048/2048) = -\text{REF IN}$

Note: 1 LSB = $\text{REF IN}/2048$.

MICROPROCESSOR INTERFACING—AD7247A

Figures 10 to 12 show interfaces between the AD7247A and the ADSP-2101 DSP processor and the 8086 and 68000 16-bit microprocessors. In all three interfaces, the AD7247A is memory-mapped with a separate memory address for each DAC.

AD7247A—ADSP-2101 Interface

Figure 10 shows an interface between the AD7247A and the ADSP-2101. The 12-bit word is written to the selected DAC latch of the AD7247A in a single instruction, and the analog output responds immediately. Depending on the clock frequency of the ADSP-2101, either one or two wait states will have to be programmed into the data memory wait state control register of the ADSP-2101.

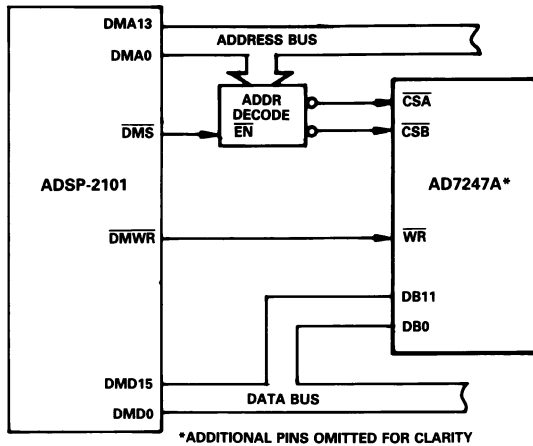

Figure 10. AD7247A to ADSP-2101 Interface

AD7247A—8086 Interface

Figure 11 shows an interface between the AD7247A and the 8086 microprocessor. The 12-bit word is written to the selected DAC latch of the AD7247A in a single MOV instruction, and the analog output responds immediately.

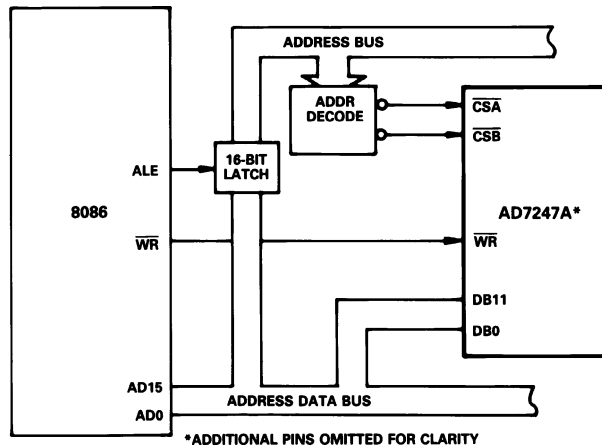

Figure 11. AD7247A to 8086 Interface

AD7247A—MC68000 Interface

Interfacing between the AD7247A and the MC68000 microprocessor is achieved using the circuit of Figure 12. Once again, the 12-bit word is written to the selected DAC latch of the AD7247A in a single MOVE instruction. \overline{CSA} and \overline{CSB} have to be AND-gated to provide a \overline{DTACK} signal for the MC68000 when either DAC latch is selected.

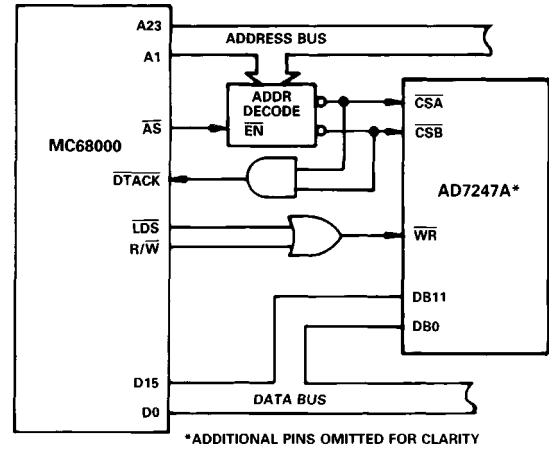

Figure 12. AD7247A to MC68000 Interface

MICROPROCESSOR INTERFACING—AD7237A

Figures 13 to 15 show the AD7237A configured for interfacing to microprocessors with 8-bit databus systems. In all cases, data is right-justified, and the AD7237A is memory-mapped with the two lowest address lines of the microprocessor address bus driving the A0 and A1 inputs of the converter.

AD7237A—8085A/8088 Interface

Figure 13 shows the connection diagram for interfacing the AD7237A to both the 8085A and the 8088. This scheme is also suited to the Z80 microprocessor, but the Z80 address/ databus does not have to be demultiplexed. The AD7237A requires five separate memory addresses, one for the each MS latch and one for each LS latch and one for the common \overline{LDAC} input. Data is written to the respective input latch in two write operations.

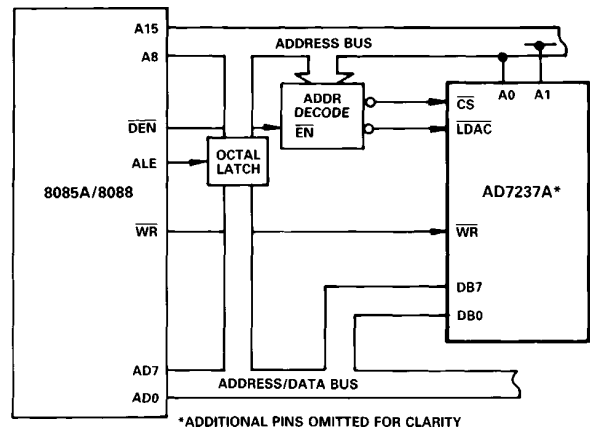

Figure 13. AD7237A to 8085A/8088 Interface

AD7237A/AD7247A

Either high byte or low byte data can be written first to the input latch. A write to the AD7237A DAC Latch address transfers the data from the input latches to the respective DAC latches and updates both analog outputs. Alternatively, the $\overline{\text{LDAC}}$ input can be asynchronous or can be common to a number of AD7237As for simultaneous updating of a number of voltage channels.

AD7237A—68008 Interface

An interface between the AD7237A and the 68008 is shown in Figure 14. In the diagram shown, the $\overline{\text{LDAC}}$ is derived from an asynchronous $\overline{\text{LDAC}}$ signal, but this can be derived from the address decoder as in the previous interface diagram.

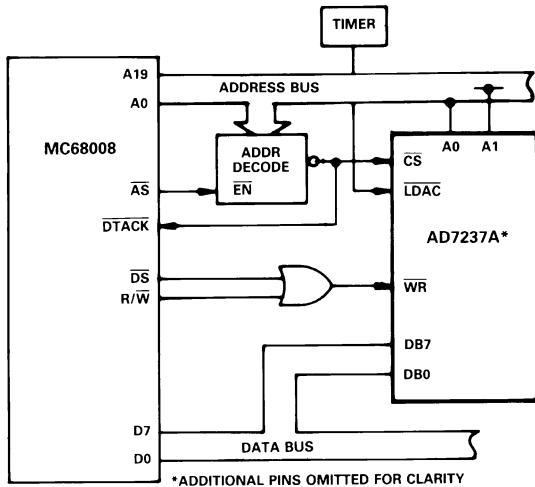

Figure 14. AD7237A to 68008 Interface

AD7237A—6502/6809 Interface

Figure 15 shows an interface between the AD7237A and the 6502 or 6809 microprocessor. The procedure for writing data to the AD7237A is as outlined for the 8085A/8088 interface. For the 6502 microprocessor, the $\phi 2$ clock is used to generate the $\overline{\text{WR}}$, while for the 6809 the E signal is used.

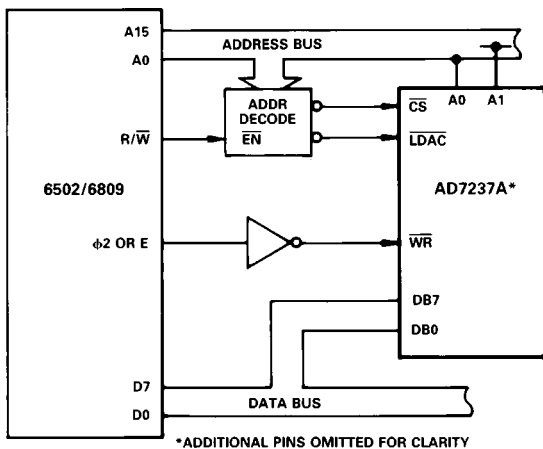
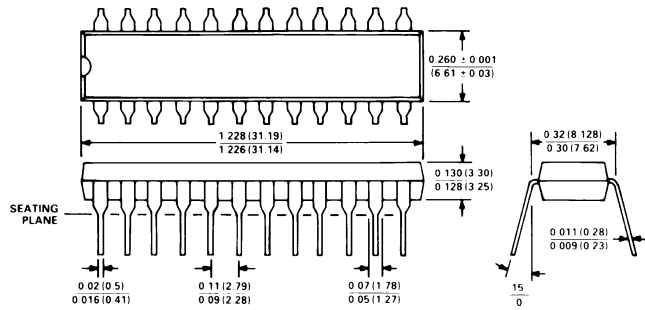

Figure 15. AD7237A to 6502/6809 Interface

OUTLINE DIMENSIONS

Dimensions shown in inches and (mm).

Plastic DIP (N-24)



- LEAD NO. 1 IDENTIFIED BY DOT OR NOTCH.
- PLASTIC LEADS WILL BE EITHER SOLDER DIPPED OR TIN LEAD PLATED IN ACCORDANCE WITH MIL-M-38510 REQUIREMENTS.

Cerdip (Q-24)

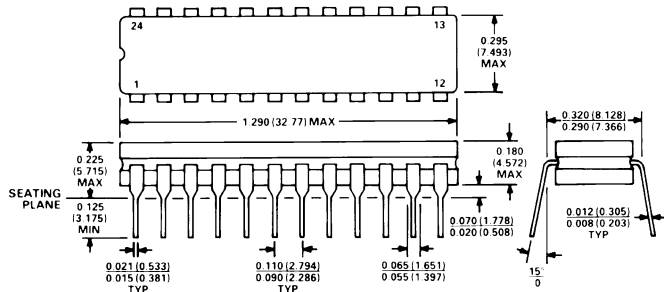

- LEAD NO. 1 IDENTIFIED BY DOT OR NOTCH.
- CERDIP LEADS WILL BE EITHER TIN PLATED OR SOLDER DIPPED IN ACCORDANCE WITH MIL-M-38510 REQUIREMENTS.

SOIC (R-24)

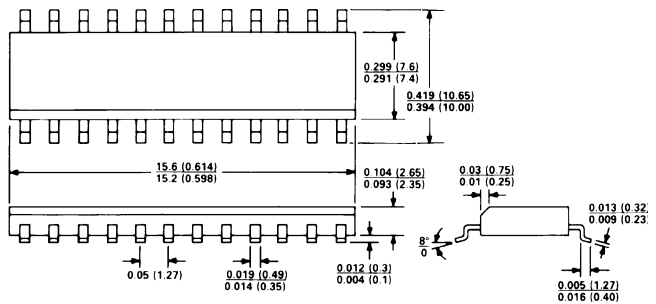

C1744-24-3/93

PRINTED IN U.S.A.

Looking for pricing, stock, or lifecycle information?

Click below to explore more details on WIN SOURCE:

 [View AD7237AAN on WIN SOURCE](#)

 [Analog Devices Inc. Information](#)

Optimize Your Supply Chain with WIN SOURCE Solutions

-  Global Sourcing Solution
-  Obsolete Management
-  Cost Control Management
-  Shortage Management
-  Alternative Solution
-  Excess Inventory Management