



# TLC542C, TLC542I 8-BIT ANALOG-TO-DIGITAL CONVERTERS WITH SERIAL CONTROL AND 11 INPUTS

SLAS075C – FEBRUARY 1989 – REVISED JUNE 2001

- 8-Bit Resolution A/D Converter
- Microprocessor Peripheral or Stand-Alone Operation
- On-Chip 12-Channel Analog Multiplexer
- Built-In Self-Test Mode
- Software-Controllable Sample and Hold
- Total Unadjusted Error . . .  $\pm 0.5$  LSB Max
- Direct Replacement for Motorola MC145041
- Onboard System Clock
- End-of-Conversion (EOC) Output
- Pinout and Control Signals Compatible With the TLC1542/3 10-Bit A/D Converters
- CMOS Technology

PARAMETER	VALUE
Channel Acquisition/Sample Time	16 $\mu$ s
Conversion Time (Max)	20 $\mu$ s
Samples per Second (Max)	$25 \times 10^3$
Power Dissipation (Max)	10 mW

## description

The TLC542 is a CMOS converter built around an 8-bit switched-capacitor successive-approximation analog-to-digital converter. The device is designed for serial interface to a microprocessor or peripheral via a 3-state output with three inputs [including I/O CLOCK,  $\overline{CS}$  (chip select), and ADDRESS INPUT]. The TLC542 allows high-speed data transfers and

sample rates of up to 40,000 samples per second. In addition to the high-speed converter and versatile control logic, an on-chip 12-channel analog multiplexer can sample any one of 11 inputs or an internal *self-test* voltage, and the sample and hold is started under microprocessor control. At the end of conversion, the end-of-conversion (EOC) output pin goes high to indicate that conversion is complete.

The converter incorporated in the TLC542 features differential high-impedance reference inputs that facilitate ratiometric conversion, scaling, and isolation of analog circuitry from logic and supply noises. A switched-capacitor design allows low-error ( $\pm 0.5$  LSB) conversion in 20  $\mu$ s over the full operating temperature range.

The TLC542C is characterized for operation from 0°C to 70°C and the TLC542I is characterized for operation from -40°C to 85°C.

DW OR N PACKAGE  
(TOP VIEW)

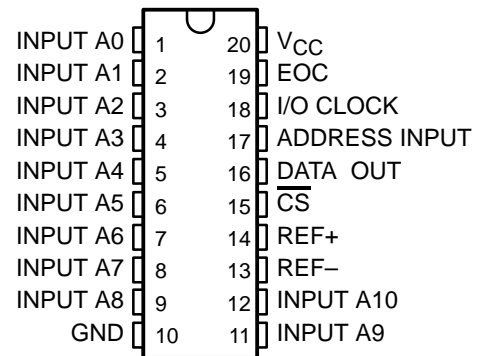

FN PACKAGE  
(TOP VIEW)

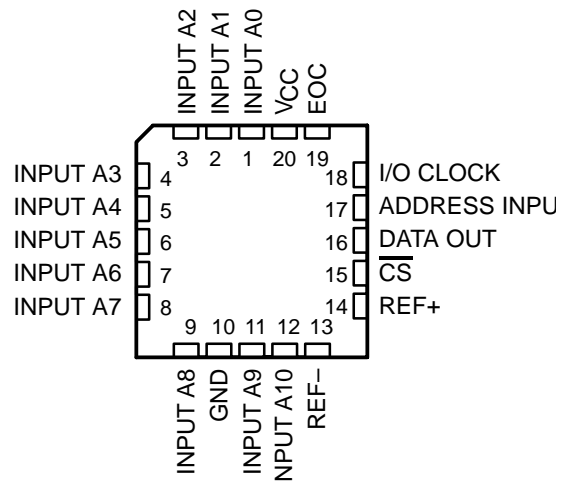

## AVAILABLE OPTIONS

T <sub>A</sub>	PACKAGE		
	CHIP CARRIER (FN)	PLASTIC DIP (N)	SMALL OUTLINE (DW)
0°C to 70°C	—	TLC542CN	TLC542CDW
-40°C to 85°C	TLC542IFN	TLC542IN	TLC542IDW



Please be aware that an important notice concerning availability, standard warranty, and use in critical applications of Texas Instruments semiconductor products and disclaimers thereto appears at the end of this data sheet.

PRODUCTION DATA information is current as of publication date. Products conform to specifications per the terms of Texas Instruments standard warranty. Production processing does not necessarily include testing of all parameters.

**TEXAS  
INSTRUMENTS**

POST OFFICE BOX 655303 • DALLAS, TEXAS 75265

Copyright © 2001, Texas Instruments Incorporated

# TLC542C, TLC542I

## 8-BIT ANALOG-TO-DIGITAL CONVERTERS

### WITH SERIAL CONTROL AND 11 INPUTS

SLAS075C – FEBRUARY 1989 – REVISED JUNE 2001

#### functional block diagram

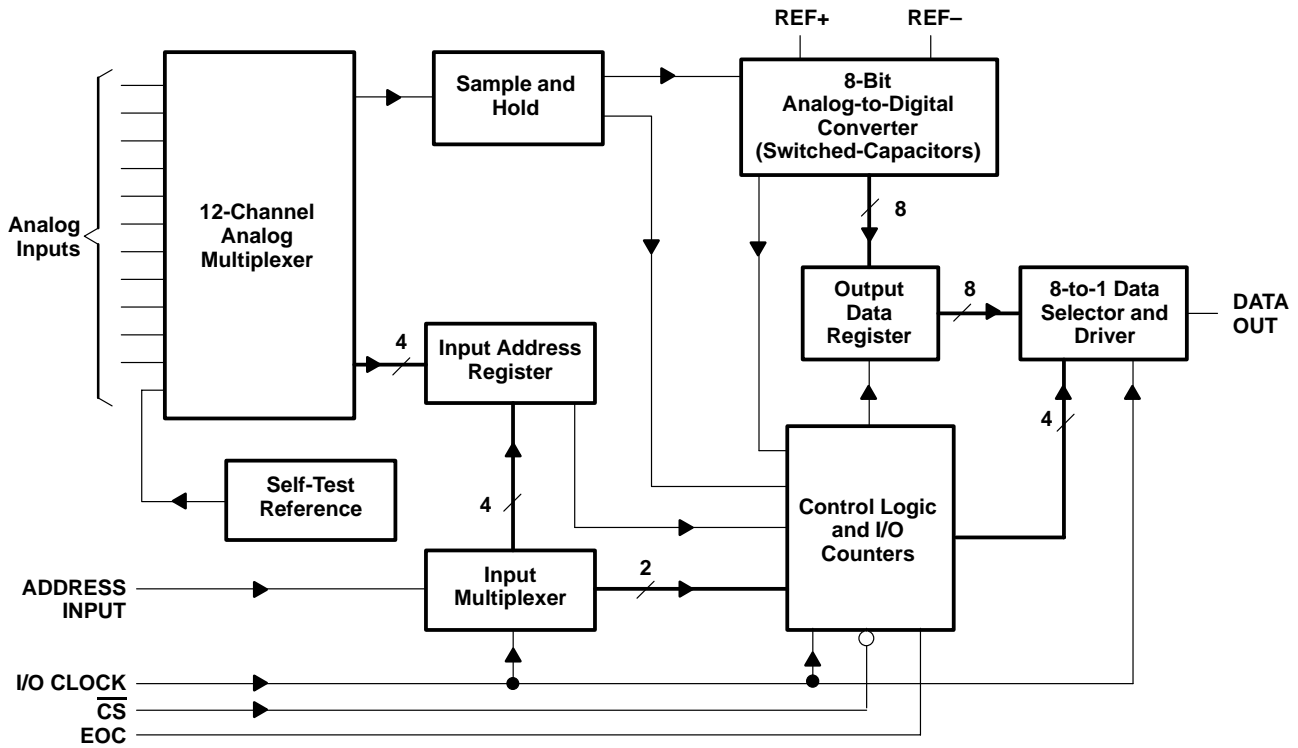

#### typical equivalent inputs

INPUT CIRCUIT IMPEDANCE DURING SAMPLING MODE

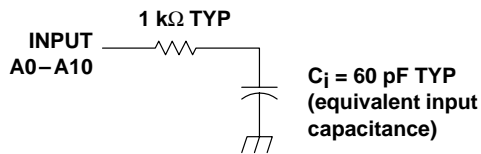

INPUT CIRCUIT IMPEDANCE DURING HOLD MODE

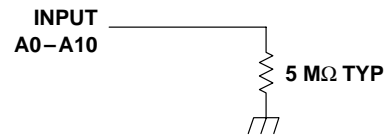

# TLC542C, TLC542I

## 8-BIT ANALOG-TO-DIGITAL CONVERTERS WITH SERIAL CONTROL AND 11 INPUTS

SLAS075C – FEBRUARY 1989 – REVISED JUNE 2001

### operating sequence

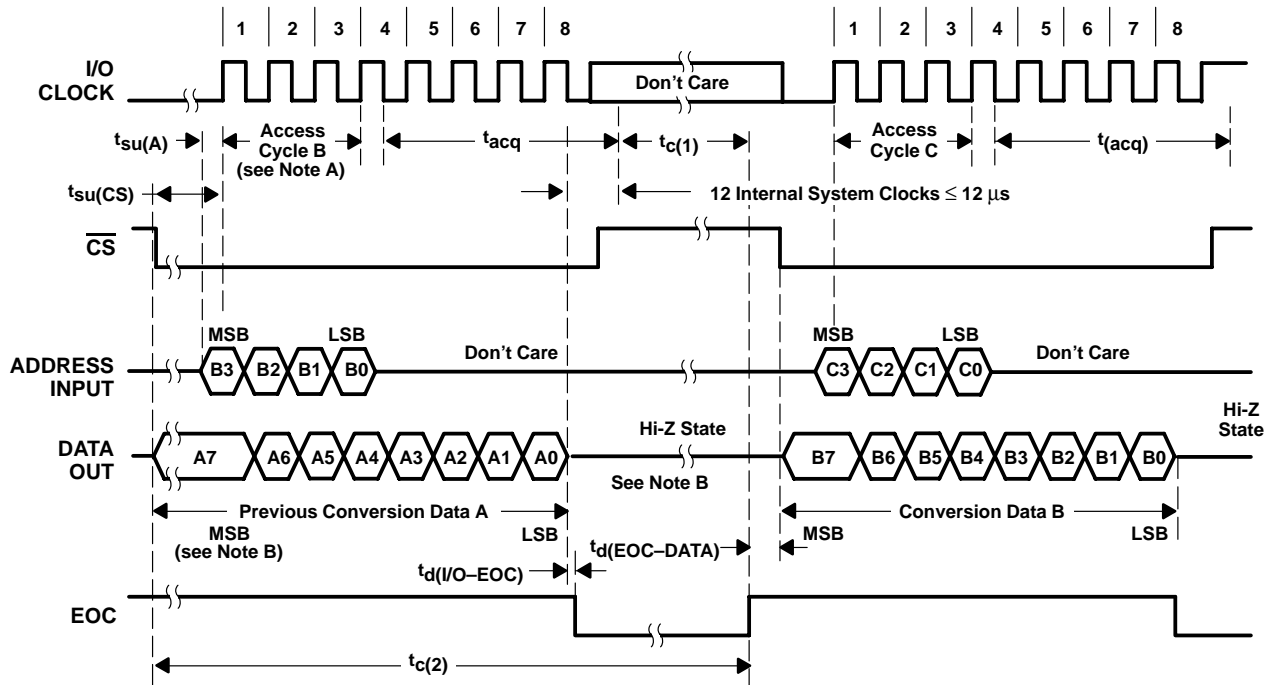

- NOTES: A. To minimize errors caused by noise at the chip select input, the internal circuitry waits for two rising edges and one falling edge of the internal system clock after  $\overline{CS}$  before responding to control input signals. The  $\overline{CS}$  setup time is given by the  $t_{su}(CS)$  specifications. Therefore, no attempt should be made to clock-in an address until the minimum chip select setup time has elapsed.
- B. The output becomes 3-state on  $\overline{CS}$  going high or on the negative edge of the eighth I/O clock.

### absolute maximum ratings over operating free-air temperature range (unless otherwise noted)†

Supply voltage, $V_{CC}$ (see Note 1)	6.5 V
Input voltage range (any input)	-0.3 V to $V_{CC} + 0.3$ V
Output voltage range, $V_O$	-0.3 V to $V_{CC} + 0.3$ V
Peak input current range (any input), $I_{p-p}$	$\pm 20$ mA
Peak total input current (all inputs), $I_P$	$\pm 30$ mA
Operating free-air temperature range: TLC542C	0°C to 70°C
TLC542I	-40°C to 85°C
Storage temperature range, $T_{stg}$	-65°C to 150°C
Case temperature for 10 seconds, $T_C$ : FN package	260°C
Lead temperature 1,6 mm (1/16 inch) from case for 10 seconds: DW or N package	260°C

† Stresses beyond those listed under "absolute maximum ratings" may cause permanent damage to the device. These are stress ratings only, and functional operation of the device at these or any other conditions beyond those indicated under "recommended operating conditions" is not implied. Exposure to absolute-maximum-rated conditions for extended periods may affect device reliability.

NOTE 1: All voltage values are with respect to digital ground with REF- and GND wired together (unless otherwise noted).



# TLC542C, TLC542I

## 8-BIT ANALOG-TO-DIGITAL CONVERTERS

### WITH SERIAL CONTROL AND 11 INPUTS

SLAS075C – FEBRUARY 1989 – REVISED JUNE 2001

#### recommended operating conditions, $V_{CC} = 4.75$ to $5.5$ V

	MIN	NOM	MAX	UNIT
Supply voltage, $V_{CC}$	4.75	5	5.5	V
Positive reference voltage, $V_{ref+}$ (see Note 2)	$V_{ref-}$	$V_{CC}$	$V_{CC} + 0.1$	V
Negative reference voltage, $V_{ref-}$ (see Note 2)	-0.1	0	$V_{ref+}$	V
Differential reference voltage, $V_{ref+} - V_{ref-}$ (see Note 2)	1	$V_{CC}$	$V_{CC} + 0.2$	V
Analog input voltage (see Note 3)	0		$V_{CC}$	V
High-level control input voltage, $V_{IH}$	2			V
Low-level control input voltage, $V_{IL}$			0.8	V
Setup time, address bits at data input before I/O CLOCK $\uparrow$ , $t_{su(A)}$	400			ns
Hold time, address bits after I/O CLOCK $\uparrow$ , $t_h(A)$	0			ns
Hold time, $\overline{CS}$ low after 8th I/O CLOCK $\uparrow$ , $t_h(CS)$	0			ns
Setup time, $\overline{CS}$ low before clocking in first address bit, $t_{su}(CS)$ (see Note 4)	3.8			$\mu$ s
Input/output clock frequency, $f_{(clock\ I/O)}$	0	1.1		MHz
Input/output clock high, $t_w(H\ I/O)$	404			ns
Input/output clock low, $t_w(L\ I/O)$	404			ns
I/O CLOCK transition time, $t_t$ (see Note 3)	$f_{clock(I/O)} \leq 525$ kHz		100	ns
	$f_{clock(I/O)} > 525$ kHz		40	
Operating free-air temperature, $T_A$	TLC542C		0	$^{\circ}$ C
	TLC542I		-40	

- NOTES: 2. Analog input voltages greater than that applied to REF+ convert as all ones (11111111), while input voltages less than that applied to REF- convert as all zeros (00000000). For proper operation, REF+ must be at least 1 V higher than REF-. Also, the total unadjusted error may increase as this differential reference voltage falls below 4.75 V.
3. This is the time required for the clock input signal to fall from  $V_{IH}$  min to  $V_{IL}$  max or to rise from  $V_{IL}$  max to  $V_{IH}$  min. In the vicinity of normal room temperature, the devices function with input clock transition time as slow as 2  $\mu$ s for remote data acquisition applications where the sensor and the A/D converter are placed several feet away from the controlling microprocessor.
4. To minimize errors caused by noise at the chip select input, the internal circuitry waits for two rising edges and one falling edge of the internal system clock after  $\overline{CS} \downarrow$  before responding to control input signals. The  $\overline{CS}$  setup time is given by the  $t_{su}(CS)$  specifications. Therefore, no attempt should be made to clock-in address data until the minimum chip select setup time has elapsed.

#### electrical characteristics over recommended operating temperature range, $V_{CC} = V_{ref+} = 4.75$ V to $5.5$ V, $f_{(clock\ I/O)} = 1.1$ MHz (unless otherwise noted)

PARAMETER		TEST CONDITIONS	MIN	TYP $\dagger$	MAX	UNIT
$V_{OH}$	High-level output voltage (DATA OUT)	$V_{CC} = 4.75$ V, $I_{OH} = -360$ $\mu$ A	2.4			V
$V_{OL}$	Low-level output voltage	$V_{CC} = 4.75$ V, $I_{OL} = 1.6$ mA			0.4	V
	Off-state (high-impedance state) output current	$V_O = V_{CC}$ , $\overline{CS}$ at $V_{CC}$			10	$\mu$ A
		$V_O = 0$ , $\overline{CS}$ at $V_{CC}$			-10	
$I_{IH}$	High-level input current	$V_I = V_{CC}$		0.005	2	$\mu$ A
$I_{IL}$	Low-level input current	$V_I = 0$		-0.005	-2.5	$\mu$ A
$I_{CC}$	Operating supply current	$\overline{CS}$ at 0 V		1.2	2	mA
	Selected channel leakage current	Selected channel at $V_{CC}$ and unselected channel at 0 V			0.4	$\mu$ A
		Selected channel at 0 V and unselected channel at $V_{CC}$			-0.4	
$I_{ref}$	Maximum static analog reference current into REF+	$V_{ref+} = V_{CC}$ , $V_{ref-} = GND$			10	$\mu$ A
$C_i$	Input capacitance	Analog inputs		7	55	pF
		Control inputs		5	15	

$\dagger$  All typical values are at  $T_A = 25^{\circ}$ C.



**TLC542C, TLC542I**  
**8-BIT ANALOG-TO-DIGITAL CONVERTERS**  
**WITH SERIAL CONTROL AND 11 INPUTS**

SLAS075C – FEBRUARY 1989 – REVISED JUNE 2001

**operating characteristics over recommended operating free-air temperature range,**  
 $V_{CC} = V_{ref+} = 4.75$  to  $5.5$  V,  $f_{(clock\ I/O)} = 1$  MHz

PARAMETER		TEST CONDITIONS	MIN	TYP†	MAX	UNIT
$E_L$	Linearity error (see Note 5)				±0.5	LSB
$E_{ZS}$	Zero-scale error (see Note 6)	See Note 2			±0.5	LSB
$E_{FS}$	Full-scale error (see Note 6)	See Note 2			±0.5	LSB
	Total unadjusted error (see Note 7)				±0.5	LSB
	Self-test output code	Input A11 address = 1011, See Note 8	01111101 (126)	128	10000011 (130)	
$t_{c(1)}$	Conversion time	See operating sequence			20	μs
$t_{c(2)}$	Total access and conversion cycle time	See operating sequence			40	μs
$t_{(acq)}$	Channel acquisition time (sample cycle)	See operating sequence			16	μs
$t_{(v)}$	Time output data remains valid after I/O CLK↓	See Figure 5	10			ns
$t_{d(I/O-DATA)}$	Delay time, I/O CLK↓ to data output valid	See Figure 5			400	ns
$t_{d(I/O-EOC)}$	Delay time, 8th I/O CLK↓ to EOC↓	See Figure 6			500	ns
$t_{d(EOC-DATA)}$	Delay time, EOC↑ to data out (MSB)	See Figure 7			400	ns
$t_{PZH}, t_{PZL}$	Delay time, CS↓ to data out (MSB)	See Figure 2			3.4	μs
$t_{PHZ}, t_{PLZ}$	Delay time, CS↑ to data out (MSB)	See Figure 2			150	ns
$t_r(EOC)$	Rise time	See Figure 7			100	ns
$t_f(EOC)$	Fall time	See Figure 6			100	ns
$t_r(bus)$	Data bus rise time	See Figure 5			300	ns
$t_f(bus)$	Data bus fall time	See Figure 5			300	ns

† All typical values are at  $T_A = 25^\circ\text{C}$ .

- NOTES:
2. Analog input voltages greater than that applied to REF+ convert to all ones (11111111), while input voltages less than that applied to REF- convert to all zeros (00000000). For proper operation, REF+ must be at least 1 V higher than REF-. Also, the total unadjusted error may increase as this differential reference voltage falls below 4.75 V.
  5. Linearity error is the maximum deviation from the best straight line through the A/D transfer characteristics.
  6. Zero-scale error is the difference between 00000000 and the converted output for zero input voltage; full-scale error is the difference between 11111111 and the converted output for full-scale input voltage.
  7. Total unadjusted error is the sum of linearity, zero-scale, and full-scale errors.
  8. Both the input address and the output codes are expressed in positive logic. The A11 analog input signal is internally generated and is used for test purposes.



**TLC542C, TLC542I**  
**8-BIT ANALOG-TO-DIGITAL CONVERTERS**  
**WITH SERIAL CONTROL AND 11 INPUTS**

SLAS075C – FEBRUARY 1989 – REVISED JUNE 2001

**PARAMETER MEASUREMENT INFORMATION**

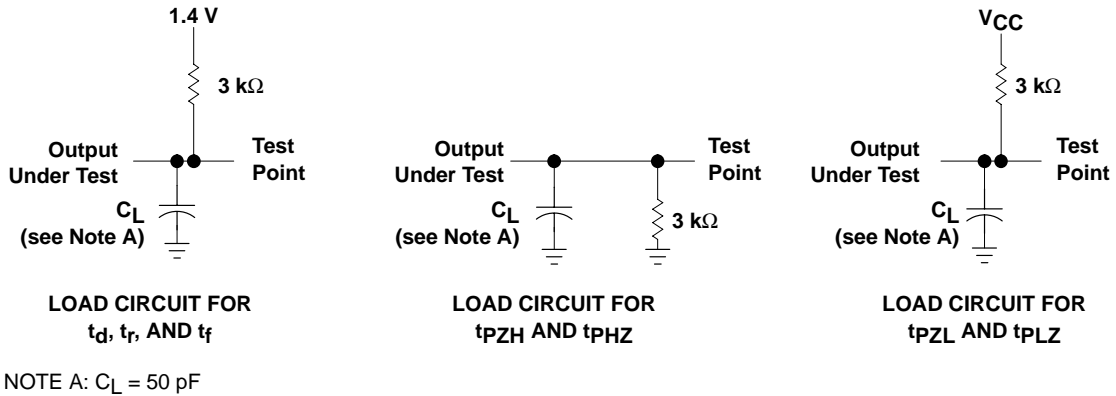

**Figure 1. Load Circuits**

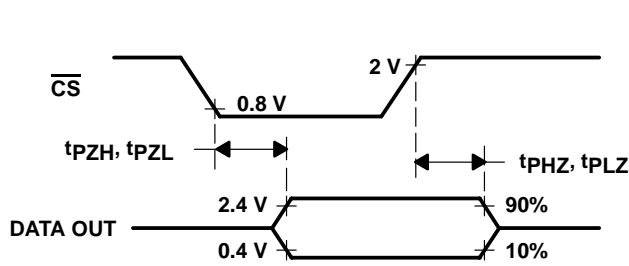

**Figure 2.  $\overline{\text{CS}}$  to Data Output Timing**

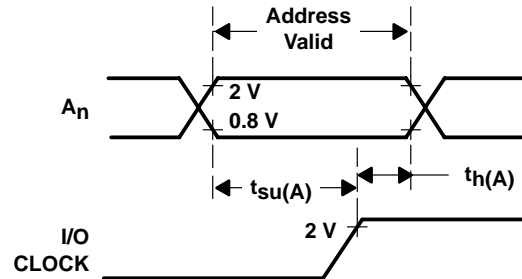

**Figure 3. Address Timing**

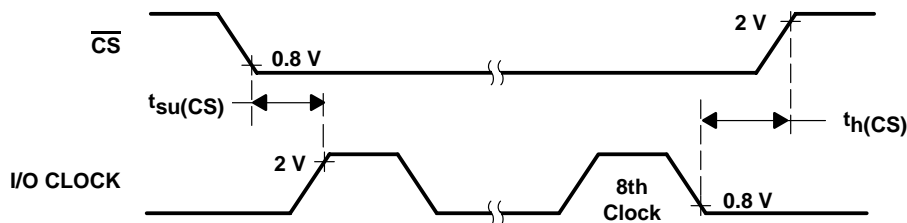

**Figure 4.  $\overline{\text{CS}}$  to I/O CLOCK Timing**

PARAMETER MEASUREMENT INFORMATION

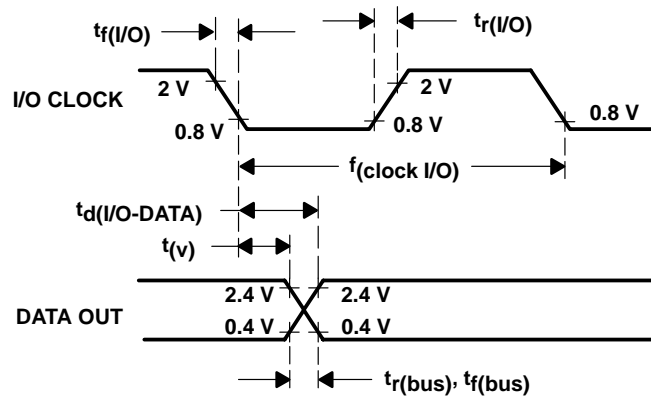

Figure 5. Data Output Timing

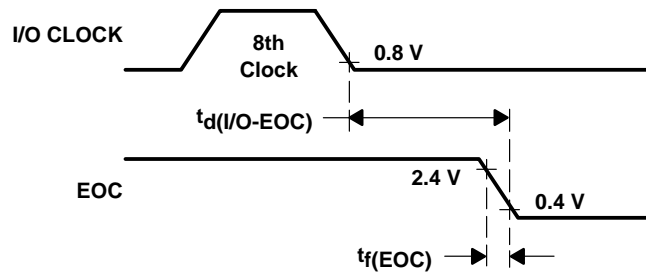

Figure 6. EOC Timing

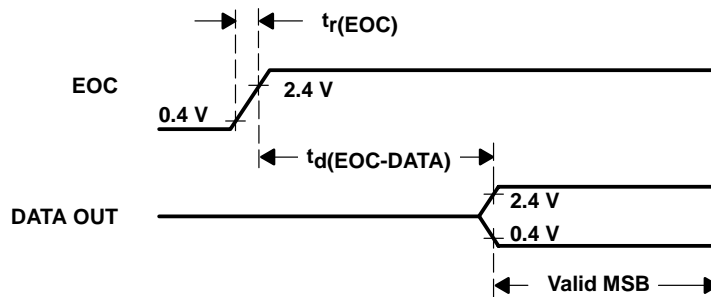

Figure 7. Data Output to EOC Timing

**APPLICATION INFORMATION**

**simplified analog input analysis**

Using the equivalent circuit in Figure 8, the time required to charge the analog input capacitance from 0 to  $V_S$  within 1/2 LSB can be derived as follows:

The capacitance charging voltage is given by

$$V_C = V_S \left(1 - e^{-t_c/R_t C_i}\right) \tag{1}$$

where

$$R_t = R_s + r_i$$

The final voltage to 1/2 LSB is given by

$$V_C (1/2 \text{ LSB}) = V_S - (V_S/512) \tag{2}$$

Equating equation 1 to equation 2 and solving for time  $t_c$  gives

$$V_S - (V_S/512) = V_S \left(1 - e^{-t_c/R_t C_i}\right) \tag{3}$$

and

$$t_c (1/2 \text{ LSB}) = R_t \times C_i \times \ln(512) \tag{4}$$

Therefore, with the values given the time for the analog input signal to settle is

$$t_c (1/2 \text{ LSB}) = (R_s + 1 \text{ k}\Omega) \times 60 \text{ pF} \times \ln(512) \tag{5}$$

This time must be less than the converter sample time shown in the timing diagrams.

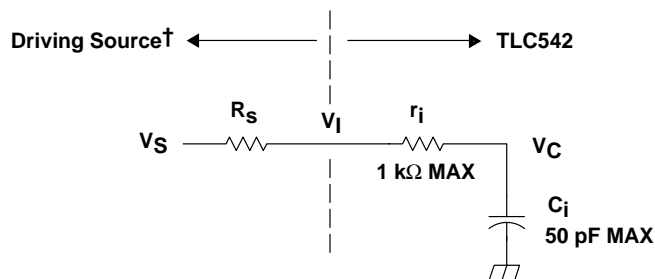

$V_I$  = Input Voltage at INPUT A0–A10  
 $V_S$  = External Driving Source Voltage  
 $R_S$  = Source Resistance  
 $r_i$  = Input Resistance  
 $C_i$  = Input Capacitance

† Driving source requirements:

- Noise and distortion for the source must be equivalent to the resolution of the converter.
- $R_S$  must be real at the input frequency.

**Figure 8. Equivalent Input Circuit Including the Driving Source**

---

## PRINCIPLES OF OPERATION

The TLC542 is a complete data acquisition system on a single chip. The device includes such functions as analog multiplexer, sample and hold, 8-bit A/D converter, data and control registers, and control logic. Three control inputs (I/O CLOCK,  $\overline{CS}$  (chip select), and ADDRESS INPUT) are included for flexibility and access speed. These control inputs and a TTL-compatible 3-state output are intended for serial communications with a microprocessor or microcomputer. With judicious interface timing, the TLC542 can complete a conversion in 20  $\mu$ s, while complete input-conversion-output cycles can be repeated every 40  $\mu$ s. Furthermore, this fast conversion can be executed on any of 11 inputs or its built-in self-test and in any order desired by the controlling processor.

When  $\overline{CS}$  is high, the DATA OUT terminal is in a 3-state condition, and the ADDRESS INPUT and I/O CLOCK terminals are disabled. When additional TLC542 devices are used, this feature allows each of these terminals, with the exception of the  $\overline{CS}$  terminal, to share a control logic point with their counterpart terminals on additional A/D devices. Thus, this feature minimizes the control logic terminals required when using multiple A/D devices.

The control sequence is designed to minimize the time and effort required to initiate conversion and obtain the conversion result. A normal control sequence is as follows:

1.  $\overline{CS}$  is brought low. To minimize errors caused by noise at the  $\overline{CS}$  input, the internal circuitry waits for two rising edges and then a falling edge of the internal system clock before recognizing the low  $\overline{CS}$  transition. The MSB of the result of the previous conversion automatically appears on the DATA OUT terminal.
2. On the first four rising edges of the I/O CLOCK, a new positive-logic multiplexer address is shifted in, with the MSB of this address shifted first. The negative edges of these four I/O CLOCK pulses shift out the second, third, fourth, and fifth most significant bits of the result of the previous conversion. The on-chip sample and hold begins sampling the newly addressed analog input after the fourth falling edge of the I/O CLOCK. The sampling operation basically involves charging the internal capacitors to the level of the analog input voltage.
3. Three clock cycles are applied to the I/O CLOCK terminal and the sixth, seventh, and eighth conversion bits are shifted out on the negative edges of these clock cycles.
4. The final eighth clock cycle is applied to the I/O CLOCK terminal. The falling edge of this clock cycle initiates a 12-system clock ( $\approx 12 \mu$ s) additional sampling period while the output is in the high-impedance state. Conversion is then performed during the next 20  $\mu$ s. After this final I/O CLOCK cycle,  $\overline{CS}$  must go high or the I/O CLOCK must remain low for at least 20  $\mu$ s to allow for the conversion function.

$\overline{CS}$  can be kept low during periods of multiple conversion. If  $\overline{CS}$  is taken high, it must remain high until the end of conversion. Otherwise, a valid falling edge of  $\overline{CS}$  causes a reset condition, which aborts the conversion process.

A new conversion may be started and the ongoing conversion simultaneously aborted by performing steps 1 through 4 before the 20- $\mu$ s conversion time has elapsed. Such action yields the conversion result of the previous conversion and not the ongoing conversion.

The end-of-conversion (EOC) output goes low on the negative edge of the eighth I/O CLOCK. The subsequent low-to-high transition of EOC indicates the A/D conversion is complete and the conversion is ready for transfer.

**PACKAGING INFORMATION**

Orderable Device	Status <sup>(1)</sup>	Package Type	Package Drawing	Pins	Package Qty	Eco Plan <sup>(2)</sup>	Lead/Ball Finish	MSL Peak Temp <sup>(3)</sup>
TLC542CDW	ACTIVE	SOIC	DW	20	25	Green (RoHS & no Sb/Br)	CU NIPDAU	Level-1-260C-UNLIM
TLC542CDWG4	ACTIVE	SOIC	DW	20	25	Green (RoHS & no Sb/Br)	CU NIPDAU	Level-1-260C-UNLIM
TLC542CDWR	ACTIVE	SOIC	DW	20	2000	Green (RoHS & no Sb/Br)	CU NIPDAU	Level-1-260C-UNLIM
TLC542CDWRG4	ACTIVE	SOIC	DW	20	2000	Green (RoHS & no Sb/Br)	CU NIPDAU	Level-1-260C-UNLIM
TLC542CN	ACTIVE	PDIP	N	20	20	Pb-Free (RoHS)	CU NIPDAU	N / A for Pkg Type
TLC542CNE4	ACTIVE	PDIP	N	20	20	Pb-Free (RoHS)	CU NIPDAU	N / A for Pkg Type
TLC542IDW	ACTIVE	SOIC	DW	20	25	Green (RoHS & no Sb/Br)	CU NIPDAU	Level-1-260C-UNLIM
TLC542IDWG4	ACTIVE	SOIC	DW	20	25	Green (RoHS & no Sb/Br)	CU NIPDAU	Level-1-260C-UNLIM
TLC542IDWR	ACTIVE	SOIC	DW	20	2000	Green (RoHS & no Sb/Br)	CU NIPDAU	Level-1-260C-UNLIM
TLC542IDWRG4	ACTIVE	SOIC	DW	20	2000	Green (RoHS & no Sb/Br)	CU NIPDAU	Level-1-260C-UNLIM
TLC542IFN	ACTIVE	PLCC	FN	20	46	Green (RoHS & no Sb/Br)	CU SN	Level-1-260C-UNLIM
TLC542IFNG3	ACTIVE	PLCC	FN	20	46	Green (RoHS & no Sb/Br)	CU SN	Level-1-260C-UNLIM
TLC542IFNR	ACTIVE	PLCC	FN	20	1000	Green (RoHS & no Sb/Br)	CU SN	Level-1-260C-UNLIM
TLC542IFNRG3	ACTIVE	PLCC	FN	20	1000	Green (RoHS & no Sb/Br)	CU SN	Level-1-260C-UNLIM
TLC542IN	ACTIVE	PDIP	N	20	20	Pb-Free (RoHS)	CU NIPDAU	N / A for Pkg Type
TLC542INE4	ACTIVE	PDIP	N	20	20	Pb-Free (RoHS)	CU NIPDAU	N / A for Pkg Type

<sup>(1)</sup> The marketing status values are defined as follows:

**ACTIVE:** Product device recommended for new designs.

**LIFEBUY:** TI has announced that the device will be discontinued, and a lifetime-buy period is in effect.

**NRND:** Not recommended for new designs. Device is in production to support existing customers, but TI does not recommend using this part in a new design.

**PREVIEW:** Device has been announced but is not in production. Samples may or may not be available.

**OBSOLETE:** TI has discontinued the production of the device.

<sup>(2)</sup> Eco Plan - The planned eco-friendly classification: Pb-Free (RoHS), Pb-Free (RoHS Exempt), or Green (RoHS & no Sb/Br) - please check <http://www.ti.com/productcontent> for the latest availability information and additional product content details.

**TBD:** The Pb-Free/Green conversion plan has not been defined.

**Pb-Free (RoHS):** TI's terms "Lead-Free" or "Pb-Free" mean semiconductor products that are compatible with the current RoHS requirements for all 6 substances, including the requirement that lead not exceed 0.1% by weight in homogeneous materials. Where designed to be soldered at high temperatures, TI Pb-Free products are suitable for use in specified lead-free processes.

**Pb-Free (RoHS Exempt):** This component has a RoHS exemption for either 1) lead-based flip-chip solder bumps used between the die and package, or 2) lead-based die adhesive used between the die and leadframe. The component is otherwise considered Pb-Free (RoHS compatible) as defined above.

**Green (RoHS & no Sb/Br):** TI defines "Green" to mean Pb-Free (RoHS compatible), and free of Bromine (Br) and Antimony (Sb) based flame retardants (Br or Sb do not exceed 0.1% by weight in homogeneous material)

<sup>(3)</sup> MSL, Peak Temp. -- The Moisture Sensitivity Level rating according to the JEDEC industry standard classifications, and peak solder temperature.

**Important Information and Disclaimer:**The information provided on this page represents TI's knowledge and belief as of the date that it is provided. TI bases its knowledge and belief on information provided by third parties, and makes no representation or warranty as to the accuracy of such information. Efforts are underway to better integrate information from third parties. TI has taken and continues to take reasonable steps to provide representative and accurate information but may not have conducted destructive testing or chemical analysis on incoming materials and chemicals. TI and TI suppliers consider certain information to be proprietary, and thus CAS numbers and other limited information may not be available for release.

In no event shall TI's liability arising out of such information exceed the total purchase price of the TI part(s) at issue in this document sold by TI to Customer on an annual basis.

## IMPORTANT NOTICE

Texas Instruments Incorporated and its subsidiaries (TI) reserve the right to make corrections, modifications, enhancements, improvements, and other changes to its products and services at any time and to discontinue any product or service without notice. Customers should obtain the latest relevant information before placing orders and should verify that such information is current and complete. All products are sold subject to TI's terms and conditions of sale supplied at the time of order acknowledgment.

TI warrants performance of its hardware products to the specifications applicable at the time of sale in accordance with TI's standard warranty. Testing and other quality control techniques are used to the extent TI deems necessary to support this warranty. Except where mandated by government requirements, testing of all parameters of each product is not necessarily performed.

TI assumes no liability for applications assistance or customer product design. Customers are responsible for their products and applications using TI components. To minimize the risks associated with customer products and applications, customers should provide adequate design and operating safeguards.

TI does not warrant or represent that any license, either express or implied, is granted under any TI patent right, copyright, mask work right, or other TI intellectual property right relating to any combination, machine, or process in which TI products or services are used. Information published by TI regarding third-party products or services does not constitute a license from TI to use such products or services or a warranty or endorsement thereof. Use of such information may require a license from a third party under the patents or other intellectual property of the third party, or a license from TI under the patents or other intellectual property of TI.

Reproduction of TI information in TI data books or data sheets is permissible only if reproduction is without alteration and is accompanied by all associated warranties, conditions, limitations, and notices. Reproduction of this information with alteration is an unfair and deceptive business practice. TI is not responsible or liable for such altered documentation. Information of third parties may be subject to additional restrictions.

Resale of TI products or services with statements different from or beyond the parameters stated by TI for that product or service voids all express and any implied warranties for the associated TI product or service and is an unfair and deceptive business practice. TI is not responsible or liable for any such statements.

TI products are not authorized for use in safety-critical applications (such as life support) where a failure of the TI product would reasonably be expected to cause severe personal injury or death, unless officers of the parties have executed an agreement specifically governing such use. Buyers represent that they have all necessary expertise in the safety and regulatory ramifications of their applications, and acknowledge and agree that they are solely responsible for all legal, regulatory and safety-related requirements concerning their products and any use of TI products in such safety-critical applications, notwithstanding any applications-related information or support that may be provided by TI. Further, Buyers must fully indemnify TI and its representatives against any damages arising out of the use of TI products in such safety-critical applications.

TI products are neither designed nor intended for use in military/aerospace applications or environments unless the TI products are specifically designated by TI as military-grade or "enhanced plastic." Only products designated by TI as military-grade meet military specifications. Buyers acknowledge and agree that any such use of TI products which TI has not designated as military-grade is solely at the Buyer's risk, and that they are solely responsible for compliance with all legal and regulatory requirements in connection with such use.

TI products are neither designed nor intended for use in automotive applications or environments unless the specific TI products are designated by TI as compliant with ISO/TS 16949 requirements. Buyers acknowledge and agree that, if they use any non-designated products in automotive applications, TI will not be responsible for any failure to meet such requirements.

Following are URLs where you can obtain information on other Texas Instruments products and application solutions:

### Products

Amplifiers	<a href="http://amplifier.ti.com">amplifier.ti.com</a>
Data Converters	<a href="http://dataconverter.ti.com">dataconverter.ti.com</a>
DLP® Products	<a href="http://www.dlp.com">www.dlp.com</a>
DSP	<a href="http://dsp.ti.com">dsp.ti.com</a>
Clocks and Timers	<a href="http://www.ti.com/clocks">www.ti.com/clocks</a>
Interface	<a href="http://interface.ti.com">interface.ti.com</a>
Logic	<a href="http://logic.ti.com">logic.ti.com</a>
Power Mgmt	<a href="http://power.ti.com">power.ti.com</a>
Microcontrollers	<a href="http://microcontroller.ti.com">microcontroller.ti.com</a>
RFID	<a href="http://www.ti-rfid.com">www.ti-rfid.com</a>
RF/IF and ZigBee® Solutions	<a href="http://www.ti.com/lprf">www.ti.com/lprf</a>

### Applications

Audio	<a href="http://www.ti.com/audio">www.ti.com/audio</a>
Automotive	<a href="http://www.ti.com/automotive">www.ti.com/automotive</a>
Broadband	<a href="http://www.ti.com/broadband">www.ti.com/broadband</a>
Digital Control	<a href="http://www.ti.com/digitalcontrol">www.ti.com/digitalcontrol</a>
Medical	<a href="http://www.ti.com/medical">www.ti.com/medical</a>
Military	<a href="http://www.ti.com/military">www.ti.com/military</a>
Optical Networking	<a href="http://www.ti.com/opticalnetwork">www.ti.com/opticalnetwork</a>
Security	<a href="http://www.ti.com/security">www.ti.com/security</a>
Telephony	<a href="http://www.ti.com/telephony">www.ti.com/telephony</a>
Video & Imaging	<a href="http://www.ti.com/video">www.ti.com/video</a>
Wireless	<a href="http://www.ti.com/wireless">www.ti.com/wireless</a>

Mailing Address: Texas Instruments, Post Office Box 655303, Dallas, Texas 75265  
Copyright © 2009, Texas Instruments Incorporated

## Looking for pricing, stock, or lifecycle information?

Click below to explore more details on WIN SOURCE:

 [View TLC542IDWR on WIN SOURCE](#)

 [Texas Instruments](#) Information

## Optimize Your Supply Chain with WIN SOURCE Solutions

-  Global Sourcing Solution
-  Obsolete Management
-  Cost Control Management
-  Shortage Management
-  Alternative Solution
-  Excess Inventory Management