



**THE DATASHEET OF  
MC100LVEP111FA**



# 2.5 V / 3.3 V 2:1:10 Differential ECL/PECL/HSTL Clock Driver

## MC100LVEP111

### Description

The MC100LVEP111 is a low skew 2:1:10 differential driver, designed with clock distribution in mind, accepting two clock sources into an input multiplexer. The PECL input signals can be either differential or single-ended (if the  $V_{BB}$  output is used). HSTL inputs can be used when the LVEP111 is operating under PECL conditions.

The LVEP111 specifically guarantees low output-to-output skew. Optimal design, layout, and processing minimize skew within a device and from device to device.

To ensure tightest skew, both sides of differential outputs identically terminate into  $50\ \Omega$  even if only one output is being used. If an output pair is unused, both outputs may be left open (unterminated) without affecting skew.

The MC100LVEP111, as with most other ECL devices, can be operated from a positive  $V_{CC}$  supply in PECL mode. This allows the LVEP111 to be used for high performance clock distribution in +3.3 V or +2.5 V systems. Single-ended CLK input operation is limited to a  $V_{CC} \geq 3.0\ \text{V}$  in PECL mode, or  $V_{EE} \leq -3.0\ \text{V}$  in NECL mode when using  $V_{BB}$  (See Figure 11). Full operating range is available when using an external voltage reference (See Figure 10). Designers can take advantage of the LVEP111's performance to distribute low skew clocks across the backplane or the board.

### Features

- 85 ps Typical Device-to-Device Skew
- 20 ps Typical Output-to-Output Skew
- Jitter Less than 1 ps RMS
- Additive RMS Phase Jitter: 60 fs @ 156.25 MHz, Typ.
- Maximum Frequency > 3 GHz Typical
- $V_{BB}$  Output
- 430 ps Typical Propagation Delay
- The 100 Series Contains Temperature Compensation
- PECL and HSTL Mode Operating Range:  $V_{CC} = 2.375\ \text{V}$  to 3.8 V with  $V_{EE} = 0\ \text{V}$
- NECL Mode Operating Range:  $V_{CC} = 0\ \text{V}$  with  $V_{EE} = -2.375\ \text{V}$  to -3.8 V
- Open Input Default State
- LVDS Input Compatible
- Fully Compatible with MC100EP111
- These are Pb-Free Devices

### MARKING DIAGRAMS\*

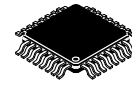

LQFP-32, 7x7  
CASE 561AB

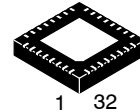
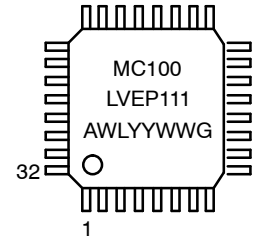

QFN32  
MN SUFFIX  
CASE 488AM

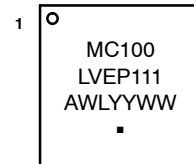

- A = Assembly Location
- WL = Wafer Lot
- YY = Year
- WW = Work Week
- G or ■ = Pb-Free Package

\*For additional marking information, refer to Application Note AND8002/D.

### ORDERING INFORMATION

See detailed ordering and shipping information in the package dimensions section on page 11 of this data sheet.

# MC100LVEP111

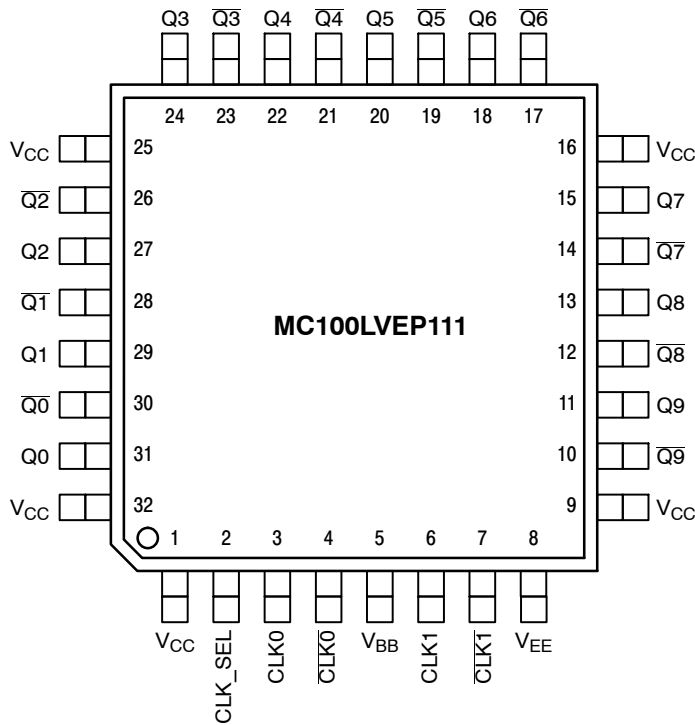

Warning: All  $V_{CC}$  and  $V_{EE}$  pins must be externally connected to Power Supply to guarantee proper operation.

Figure 1. LQFP-32 Pinout (Top View)

Table 1. PIN DESCRIPTION

PIN	FUNCTION
CLK0*, $\overline{CLK0}$ **	ECL/PECL/HSTL CLK Input
CLK1*, $\overline{CLK1}$ **	ECL/PECL/HSTL CLK Input
Q0:9, $\overline{Q0}$ :9	ECL/PECL Outputs
CLK_SEL*	ECL/PECL Active Clock Select Input
$V_{BB}$	Reference Voltage Output
$V_{CC}$	Positive Supply
$V_{EE}$	Negative Supply
EP	The exposed pad (EP) on the package bottom must be attached to a heat-sinking conduit. The exposed pad may only be electrically connected to $V_{EE}$ .

\* Pins will default LOW when left open.

\*\* Pins will default to  $2/3V_{CC}$  when left open.

Table 2. FUNCTION TABLE

CLK_SEL	Active Input
L	CLK0, $\overline{CLK0}$
H	CLK1, $\overline{CLK1}$

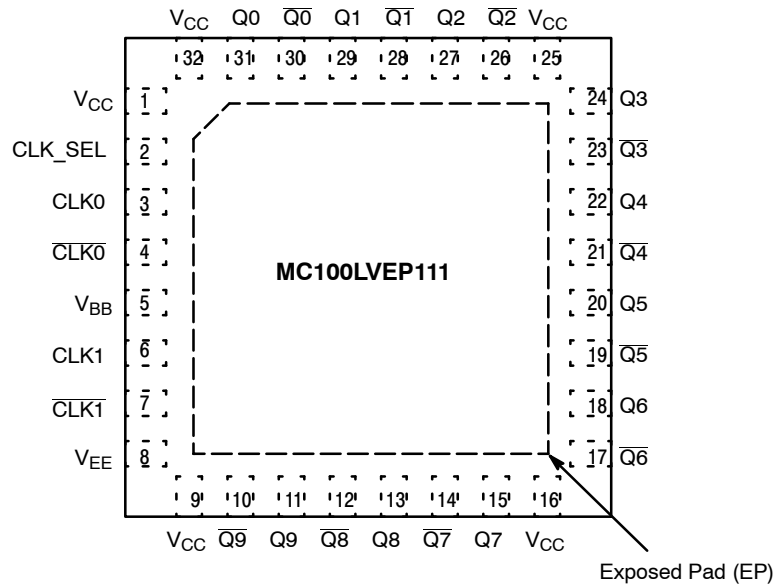

Figure 2. QFN-32 Pinout (Top View)

# MC100LVEP111

**Table 3. ATTRIBUTES**

Characteristics		Value	
Internal Input Pulldown Resistor		75 k $\Omega$	
Internal Input Pullup Resistor		37.5 k $\Omega$	
ESD Protection	Human Body Model Machine Model Charged Device Model	> 2 kV > 100 V > 2 kV	
Moisture Sensitivity (Note 1)		Pb Pkgs	Pb-Free Pkgs
		LQFP Level 2	Level 2
		QFN Level 1	Level 1
Flammability Rating	Oxygen Index: 28 to 34	UL 94 V-0 @ 0.125 in	
Transistor Count		602 Devices	
Meets or exceeds JEDEC Spec EIA/JESD78 IC Latchup Test			

1. For additional information, refer to Application Note AND8003/D.

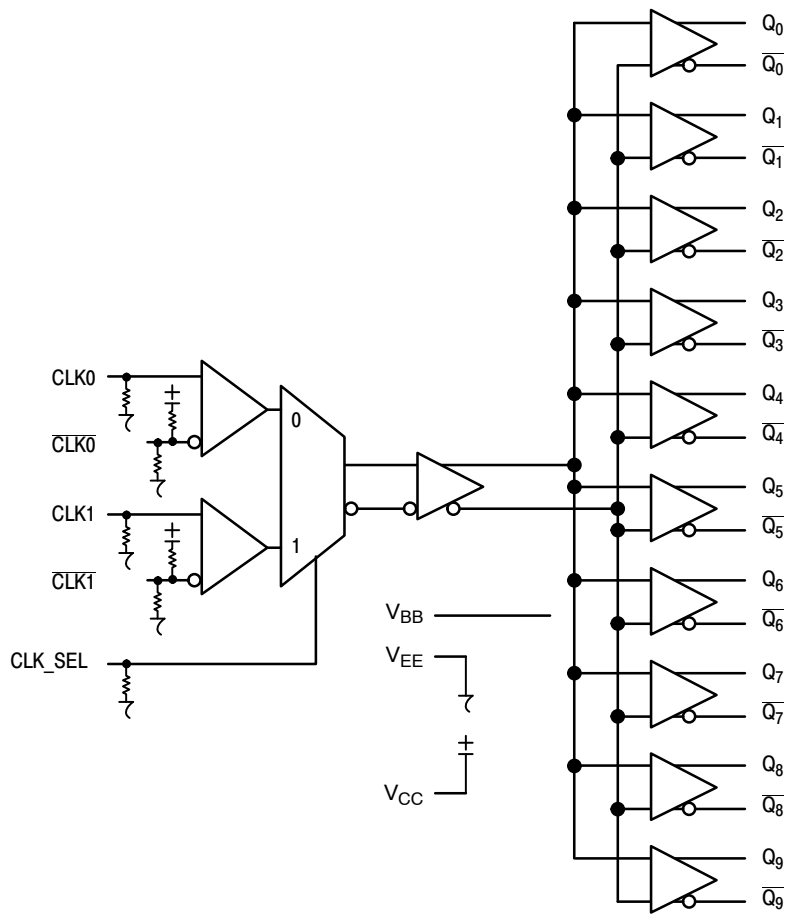

**Figure 3. Logic Diagram**

# MC100LVEP111

**Table 4. MAXIMUM RATINGS**

Symbol	Parameter	Condition 1	Condition 2	Rating	Unit
$V_{CC}$	PECL Mode Power Supply	$V_{EE} = 0\text{ V}$		6	V
$V_{EE}$	NECL Mode Power Supply	$V_{CC} = 0\text{ V}$		-6	V
$V_I$	PECL Mode Input Voltage NECL Mode Input Voltage	$V_{EE} = 0\text{ V}$ $V_{CC} = 0\text{ V}$	$V_I \leq V_{CC}$ $V_I \geq V_{EE}$	6 -6	V V
$I_{out}$	Output Current	Continuous Surge		50 100	mA mA
$I_{BB}$	$V_{BB}$ Sink/Source			$\pm 0.5$	mA
$T_A$	Operating Temperature Range			-40 to +85	$^{\circ}\text{C}$
$T_{stg}$	Storage Temperature Range			-65 to +150	$^{\circ}\text{C}$
$\theta_{JA}$	Thermal Resistance (Junction-to-Ambient)	0 lfpm 500 lfpm	LQFP-32 LQFP-32	80 55	$^{\circ}\text{C}/\text{W}$ $^{\circ}\text{C}/\text{W}$
$\theta_{JC}$	Thermal Resistance (Junction-to-Case)	Standard Board	LQFP-32	12 to 17	$^{\circ}\text{C}/\text{W}$
$\theta_{JA}$	Thermal Resistance (Junction-to-Ambient)	0 lfpm 500 lfpm	QFN-32 QFN-32	31 27	$^{\circ}\text{C}/\text{W}$ $^{\circ}\text{C}/\text{W}$
$\theta_{JC}$	Thermal Resistance (Junction-to-Case)	2S2P	QFN-32	12	$^{\circ}\text{C}/\text{W}$
$T_{sol}$	Wave Solder Pb Pb-Free (QFN-32 Only)	< 3 sec @ 248 $^{\circ}\text{C}$ < 3 sec @ 260 $^{\circ}\text{C}$		265 265	$^{\circ}\text{C}$

Stresses exceeding those listed in the Maximum Ratings table may damage the device. If any of these limits are exceeded, device functionality should not be assumed, damage may occur and reliability may be affected.

# MC100LVEP111

**Table 5. PECL DC CHARACTERISTICS**  $V_{CC} = 2.5\text{ V}$ ;  $V_{EE} = 0\text{ V}$  (Note 2)

Symbol	Characteristic	-40°C			25°C			85°C			Unit
		Min	Typ	Max	Min	Typ	Max	Min	Typ	Max	
$I_{EE}$	Power Supply Current	60	90	120	60	90	120	60	90	120	mA
$V_{OH}$	Output HIGH Voltage (Note 3)	1355	1480	1605	1355	1480	1605	1355	1480	1605	mV
$V_{OL}$	Output LOW Voltage (Note 3)	505	730	900	505	730	900	505	730	900	mV
$V_{IH}$	Input HIGH Voltage (Single-Ended) (Note 4)	1335		1620	1335		1620	1275		1620	mV
$V_{IL}$	Input LOW Voltage (Single-Ended) (Note 4)	505		875	505		875	505		875	mV
$V_{IHCMR}$	Input HIGH Voltage Common Mode Range (Differential Configuration) (Note 5)	1.2		2.5	1.2		2.5	1.2		2.5	V
$I_{IH}$	Input HIGH Current			150			150			150	$\mu\text{A}$
$I_{IL}$	Input LOW Current	CLK CLK	0.5 -150		0.5 -150			0.5 -150			$\mu\text{A}$

NOTE: Device will meet the specifications after thermal equilibrium has been established when mounted in a test socket or printed circuit board with maintained transverse airflow greater than 500 lfm.

2. Input and output parameters vary 1:1 with  $V_{CC}$ .  $V_{EE}$  can vary + 0.125 V to -1.3 V.

3. All loading with 50  $\Omega$  to  $V_{EE}$ .

4. Do not use  $V_{BB}$  at  $V_{CC} < 3.0\text{ V}$ .

5.  $V_{IHCMR}$  min varies 1:1 with  $V_{EE}$ .  $V_{IHCMR}$  max varies 1:1 with  $V_{CC}$ . The  $V_{IHCMR}$  range is referenced to the most positive side of the differential input signal.

**Table 6. PECL DC CHARACTERISTICS**  $V_{CC} = 3.3\text{ V}$ ;  $V_{EE} = 0\text{ V}$  (Note 6)

Symbol	Characteristic	-40°C			25°C			85°C			Unit
		Min	Typ	Max	Min	Typ	Max	Min	Typ	Max	
$I_{EE}$	Power Supply Current	60	90	120	60	90	120	60	90	120	mA
$V_{OH}$	Output HIGH Voltage (Note 7)	2155	2280	2405	2155	2280	2405	2155	2280	2405	mV
$V_{OL}$	Output LOW Voltage (Note 7)	1305	1530	1700	1305	1530	1700	1305	1530	1700	mV
$V_{IH}$	Input HIGH Voltage (Single-Ended)	2135		2420	2135		2420	2135		2420	mV
$V_{IL}$	Input LOW Voltage (Single-Ended)	1305		1675	1305		1675	1305		1675	mV
$V_{BB}$	Output Reference Voltage (Note 8)	1775	1875	1975	1775	1875	1975	1775	1875	1975	mV
$V_{IHCMR}$	Input HIGH Voltage Common Mode Range (Differential Configuration) (Note 9)	1.2		3.3	1.2		3.3	1.2		3.3	V
$I_{IH}$	Input HIGH Current			150			150			150	$\mu\text{A}$
$I_{IL}$	Input LOW Current	CLK CLK	0.5 -150		0.5 -150			0.5 -150			$\mu\text{A}$

NOTE: Device will meet the specifications after thermal equilibrium has been established when mounted in a test socket or printed circuit board with maintained transverse airflow greater than 500 lfm.

6. Input and output parameters vary 1:1 with  $V_{CC}$ .  $V_{EE}$  can vary + 0.925 V to -0.5 V.

7. All loading with 50  $\Omega$  to  $V_{CC} - 2.0\text{ V}$ .

8. Single ended input operation is limited  $V_{CC} \geq 3.0\text{ V}$  in PECL mode.

9.  $V_{IHCMR}$  min varies 1:1 with  $V_{EE}$ .  $V_{IHCMR}$  max varies 1:1 with  $V_{CC}$ . The  $V_{IHCMR}$  range is referenced to the most positive side of the differential input signal.

**Table 7. NECL DC CHARACTERISTICS**  $V_{CC} = 0\text{ V}$ ,  $V_{EE} = -2.375\text{ V}$  to  $-3.8\text{ V}$  (Note 10)

Symbol	Characteristic	-40°C			25°C			85°C			Unit
		Min	Typ	Max	Min	Typ	Max	Min	Typ	Max	
$I_{EE}$	Power Supply Current	60	90	120	60	90	120	60	90	120	mA
$V_{OH}$	Output HIGH Voltage (Note 11)	-1145	-1020	-895	-1145	-1020	-895	-1145	-1020	-895	mV
$V_{OL}$	Output LOW Voltage (Note 11)	-1995	-1770	-1600	-1995	-1770	-1600	-1995	-1770	-1600	mV

# MC100LVEP111

**Table 7. NECL DC CHARACTERISTICS**  $V_{CC} = 0\text{ V}$ ,  $V_{EE} = -2.375\text{ V}$  to  $-3.8\text{ V}$  (Note 10)

Symbol	Characteristic	-40°C			25°C			85°C			Unit
		Min	Typ	Max	Min	Typ	Max	Min	Typ	Max	
$V_{IH}$	Input HIGH Voltage (Single-Ended)	-1165		-880	-1165		-880	-1165		-880	mV
$V_{IL}$	Input LOW Voltage (Single-Ended)	-1995		-1625	-1995		-1625	-1995		-1625	mV
$V_{BB}$	Output Reference Voltage (Note 12)	-1525	-1425	-1325	-1525	-1425	-1325	-1525	-1425	-1325	mV
$V_{IHCMR}$	Input HIGH Voltage Common Mode Range (Differential Configuration) (Note 13)	$V_{EE} + 1.2$		0.0	$V_{EE} + 1.2$		0.0	$V_{EE} + 1.2$		0.0	V
$I_{IH}$	Input HIGH Current			150			150			150	$\mu\text{A}$
$I_{IL}$	Input LOW Current	0.5			0.5			0.5			$\mu\text{A}$
	CLK	-150			-150			-150			$\mu\text{A}$

NOTE: Device will meet the specifications after thermal equilibrium has been established when mounted in a test socket or printed circuit board with maintained transverse airflow greater than 500 lpm.

10. Input and output parameters vary 1:1 with  $V_{CC}$ .

11. All loading with  $50\ \Omega$  to  $V_{CC} - 2.0\text{ V}$ .

12. Single ended input operation is limited  $V_{EE} \leq -3.0\text{ V}$  in NECL mode.

13.  $V_{IHCMR}$  min varies 1:1 with  $V_{EE}$ ,  $V_{IHCMR}$  max varies 1:1 with  $V_{CC}$ . The  $V_{IHCMR}$  range is referenced to the most positive side of the differential input signal.

**Table 8. HSTL DC CHARACTERISTICS**  $V_{CC} = 2.375$  to  $3.8\text{ V}$ ,  $V_{EE} = 0\text{ V}$

Symbol	Characteristic	-40°C			25°C			85°C			Unit
		Min	Typ	Max	Min	Typ	Max	Min	Typ	Max	
$V_{IH}$	Input HIGH Voltage	1200			1200			1200			mV
$V_{IL}$	Input LOW Voltage			400			400			400	mV
$V_x$	Input Crossover Voltage	680		900	680		900	680		900	mV
$I_{CC}$	Power Supply Current	70	100	120	70	100	120	70	100	120	mA

NOTE: Device will meet the specifications after thermal equilibrium has been established when mounted in a test socket or printed circuit board with maintained transverse airflow greater than 500 lpm.

# MC100LVEP111

**Table 9. AC CHARACTERISTICS**  $V_{CC} = 0\text{ V}$ ;  $V_{EE} = -2.375\text{ to }-3.8\text{ V}$  or  $V_{CC} = 2.375\text{ to }3.8\text{ V}$ ;  $V_{EE} = 0\text{ V}$  (Note 14)

Symbol	Characteristic	-40°C			25°C			85°C			Unit
		Min	Typ	Max	Min	Typ	Max	Min	Typ	Max	
$f_{\text{maxPECL/HSTL}}$	Maximum Frequency (Figure 4)		3			3			3		GHz
$t_{\text{PLH}}$ $t_{\text{PHL}}$	Propagation Delay (Differential Configuration)	325	400	475	350	430	500	375	510	590	ps
$t_{\text{skew}}$	Within-Device Skew (Note 15) Within-Device Skew @ 2.5 V (Note 15) Device-to-Device Skew (Note 16)		20 20 85	25 25 150		20 20 85	25 25 150		25 20 85	35 25 150	ps
$t_{\text{JITTER}}$	CLOCK Random Jitter (RMS) @ $\leq 0.5\text{ GHz}$ @ $\leq 1.0\text{ GHz}$ @ $\leq 1.5\text{ GHz}$ @ $\leq 2.0\text{ GHz}$ @ $\leq 2.5\text{ GHz}$ @ $\leq 3.0\text{ GHz}$		0.209 0.200 0.197 0.220 0.232 0.348	0.5 0.5 0.4 0.5 0.4 0.6		0.204 0.214 0.213 0.224 0.290 0.545	0.5 0.6 0.5 0.5 0.5 0.8		0.221 0.229 0.243 0.292 0.522 0.911	0.5 0.5 0.4 0.6 0.8 1.3	ps
$t_{\text{jit}(\phi)}$	Additive RMS Phase Jitter $f_c = 156.25\text{ MHz}$ , Integration Range: 12 kHz to 20 MHz (See Figure 5)					60					fs
$V_{\text{PP}}$	Input Swing (Differential Interconnect Configuration) Measured Single-Ended	150	800	1200	150	800	1200	150	800	1200	mV
$t_r/t_f$	Output Rise/Fall Time (20%–80%)	105	200	255	125	200	275	150	230	320	ps

NOTE: Device will meet the specifications after thermal equilibrium has been established when mounted in a test socket or printed circuit board with maintained transverse airflow greater than 500 lpm.

14. Measured with 750 mV source, 50% duty cycle clock source. All loading with 50  $\Omega$  to  $V_{CC} - 2.0\text{ V}$ .

15. Skew is measured between outputs under identical transitions and conditions on any one device.

16. Device-to-Device skew for identical transitions at identical  $V_{CC}$  levels.

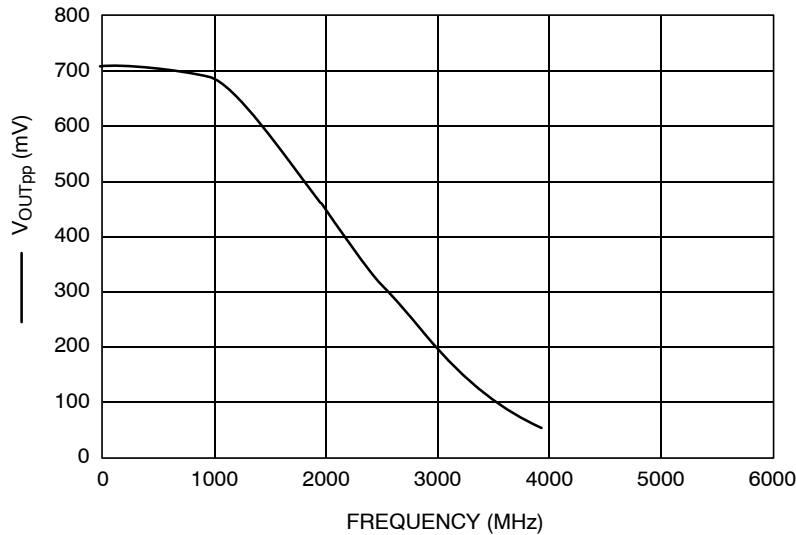

**Figure 4. F<sub>max</sub> Typical**

## MC100LVEP111

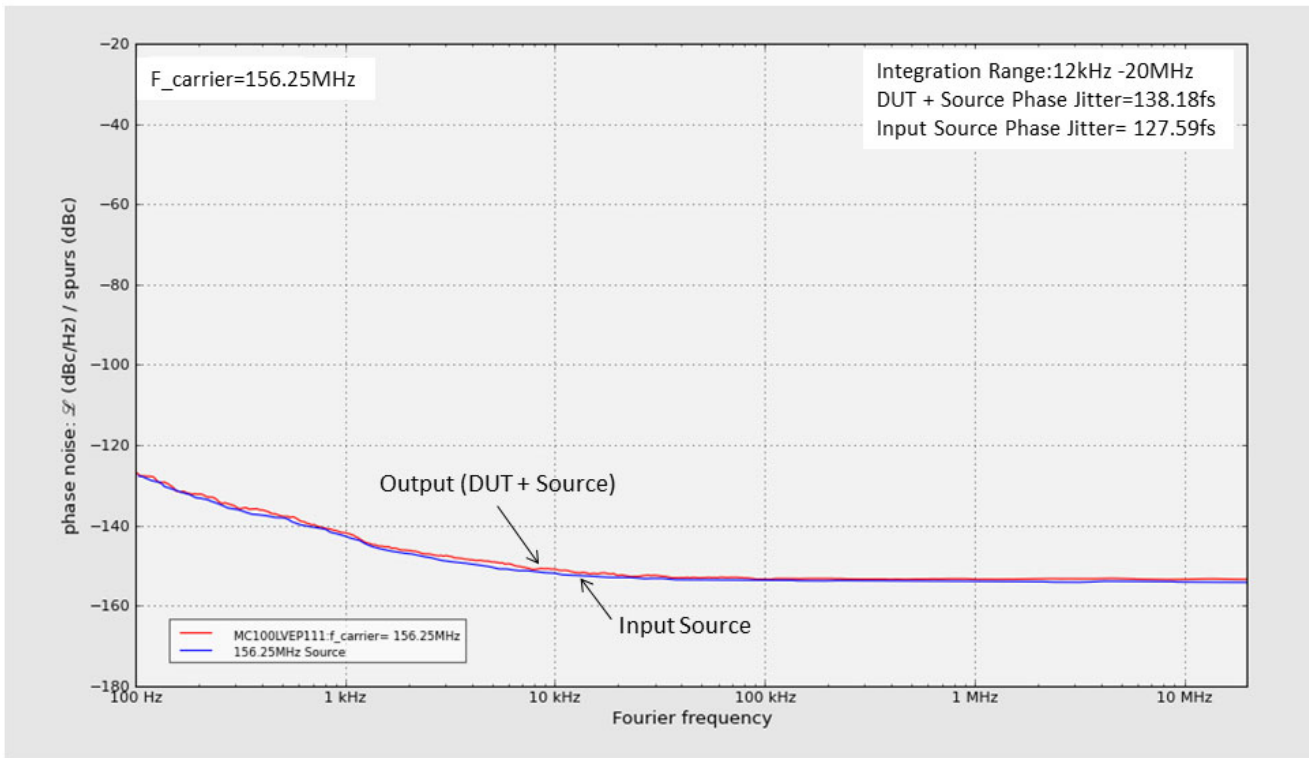

**Figure 5. Typical MC100LVEP111 Phase Noise Plot at  $f_{\text{Carrier}} = 156.25 \text{ MHz}$ ,  $V_{\text{CC}} = 3.3 \text{ V}$ ,  $25^\circ\text{C}$**

The above phase noise data was captured using Agilent E5052A/B. The data displays the input phase noise and output phase noise used to calculate the additive phase jitter at a specified integration range. The additive RMS phase jitter contributed by the device (integrated between 12 kHz and 20 MHz) is 53 fs. The additive RMS phase jitter performance of the fanout buffer is highly dependent on the phase noise of the input source.

To obtain the most precise additive phase noise measurement, it is vital that the source phase noise be

notably lower than that of the DUT. If the phase noise of the source is greater than the noise floor of the device under test, the source noise will dominate the additive phase jitter calculation and lead to an incorrect negative result for the additive phase noise within the integration range. The Figure above is a good example of the MC100LVEP111 source generator phase noise having a significantly lower floor than the DUT and results in an additive phase jitter of 53 fs.

$$\text{Additive RMS phase jitter} = \sqrt{\text{RMS phase jitter of output}^2 - \text{RMS phase jitter of input}^2}$$

$$53 \text{ fs} = \sqrt{138.18 \text{ fs}^2 - 127.59 \text{ fs}^2}$$

Figure 5 was created with measured data from Agilent E5052B Signal Source Analyzer using ON Semiconductor Phase Noise Explorer web tool. This free application enables an interactive environment for advanced

phase noise and jitter analysis of timing devices and clock tree designs. To see the performance of MC100LVEP111 beyond conditions outlined in this datasheet, please visit the ON Semiconductor [Green Point Design Tools](#) homepage.

# MC100LVEP111

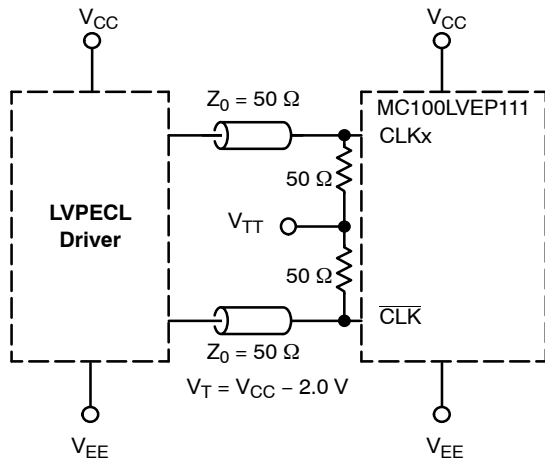

Figure 6. LVPECL in Interface

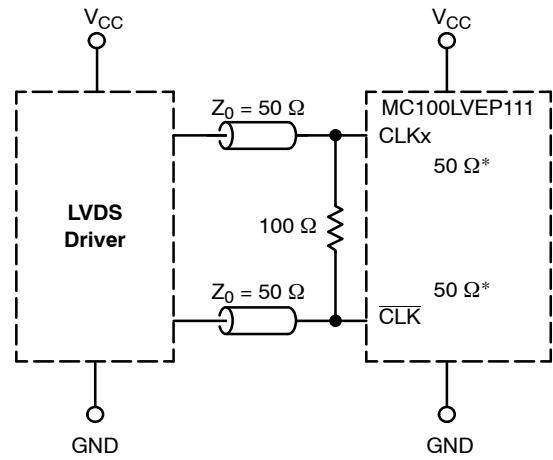

Figure 7. LVDS in Interface

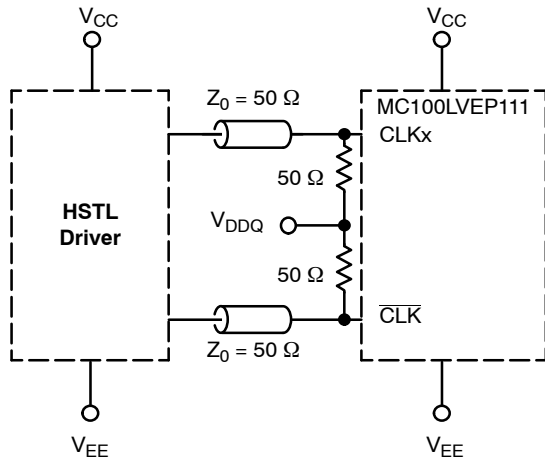

Figure 8. HSTL in Interface

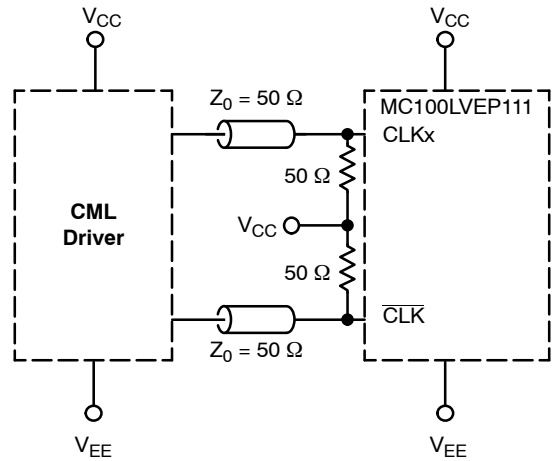

Figure 9. Standard 50 Ω Load CML in Interface

# MC100LVEP111

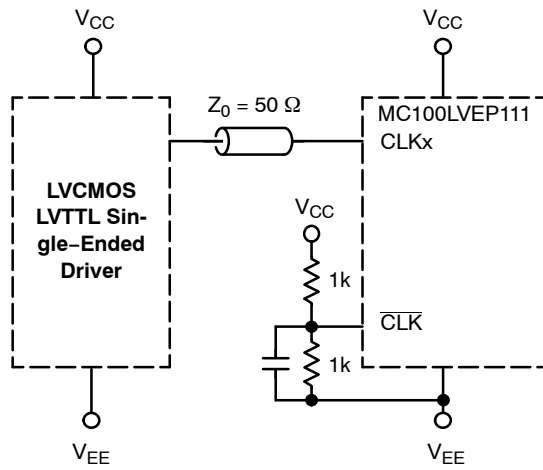

Figure 10. Single-Ended Interface LVC MOS/LVTTL in Interface Using an External Voltage Reference

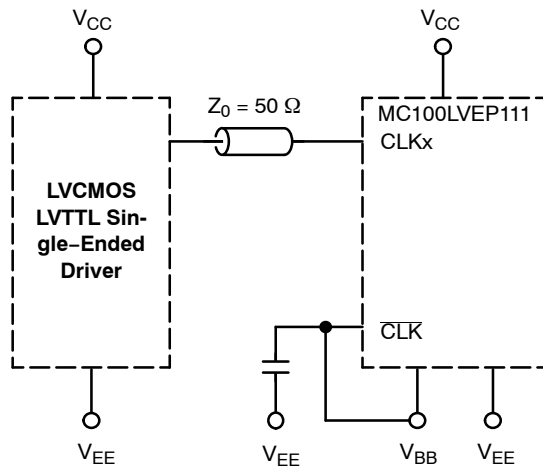
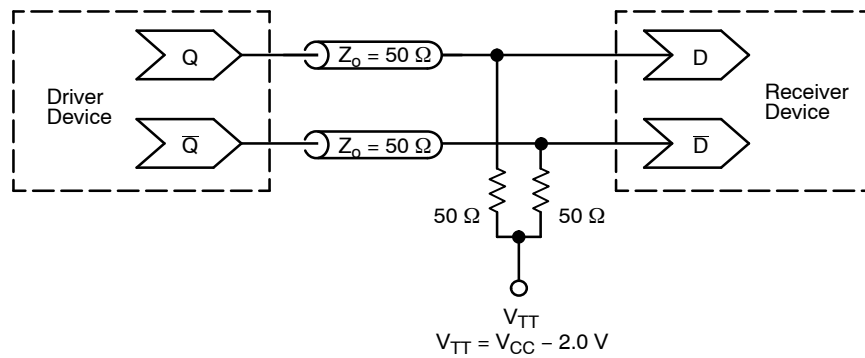
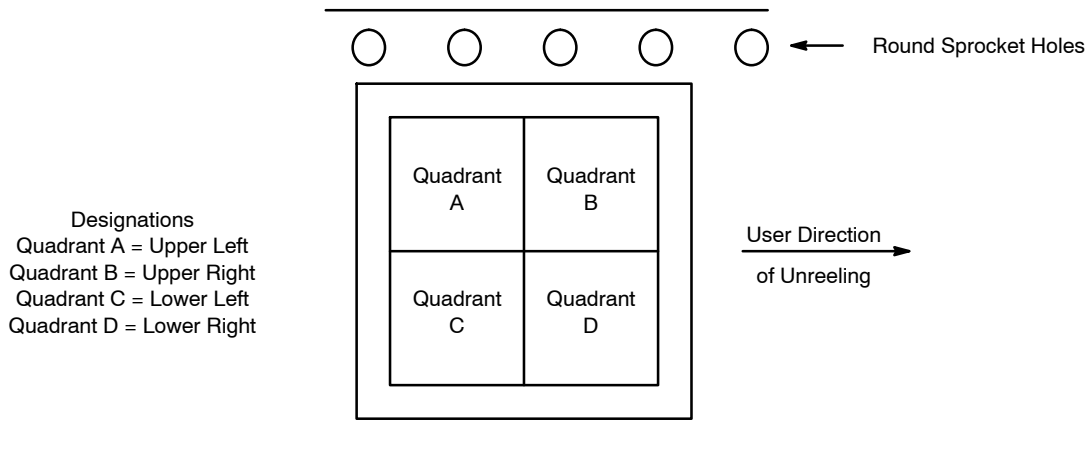

Figure 11. Single-Ended Interface LVC MOS/LVTTL in Interface Using V<sub>BB</sub>

## MC100LVEP111



**Figure 12. Typical Termination for Output Driver and Device Evaluation**  
(See Application Note AND8020/D – Termination of ECL Logic Devices.)



**Figure 13. Tape and Reel Pin 1 Quadrant Orientation**

### ORDERING INFORMATION

Device	Package	Shipping <sup>†</sup>
MC100LVEP111FAG	LQFP-32 (Pb-Free)	250 Units / Tray
MC100LVEP111FARG	LQFP-32 (Pb-Free)	2000 / Tape & Reel (Pin 1 Orientation in Quadrant B, Figure 13)
M100LVEP111FATWG	LQFP-32 (Pb-Free)	2000 / Tape & Reel (Pin 1 Orientation in Quadrant A, Figure 13)
MC100LVEP111MNG	QFN-32 (Pb-Free)	74 Units / Rail
MC100LVEP111MNRG	QFN-32 (Pb-Free)	1000 / Tape & Reel

<sup>†</sup>For information on tape and reel specifications, including part orientation and tape sizes, please refer to our Tape and Reel Packaging Specifications Brochure, BRD8011/D.

## MC100LVEP111

### Resource Reference of Application Notes

- AN1405/D** – ECL Clock Distribution Techniques
- AN1406/D** – Designing with PECL (ECL at +5.0 V)
- AN1503/D** – ECLinPS™ I/O SPiCE Modeling Kit
- AN1504/D** – Metastability and the ECLinPS Family
- AN1568/D** – Interfacing Between LVDS and ECL
- AN1672/D** – The ECL Translator Guide
- AND8001/D** – Odd Number Counters Design
- AND8002/D** – Marking and Date Codes
- AND8020/D** – Termination of ECL Logic Devices
- AND8066/D** – Interfacing with ECLinPS
- AND8090/D** – AC Characteristics of ECL Devices

ECLinPS is a trademark of Semiconductor Components Industries, LLC dba "onsemi" or its affiliates and/or subsidiaries in the United States and/or other countries.

# MECHANICAL CASE OUTLINE

## PACKAGE DIMENSIONS

ON Semiconductor®

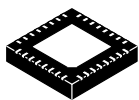

1 32

SCALE 2:1

QFN32 5x5, 0.5P  
CASE 488AM  
ISSUE A

DATE 23 OCT 2013

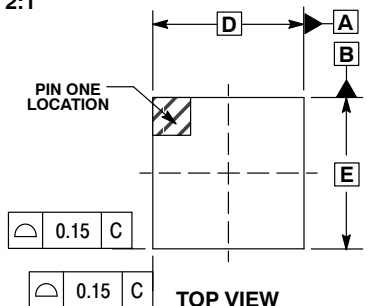

TOP VIEW

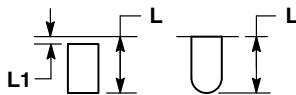

DETAIL A  
ALTERNATE TERMINAL  
CONSTRUCTIONS

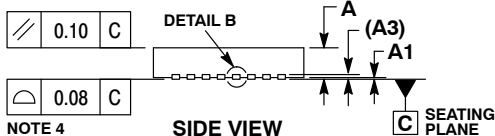

SIDE VIEW

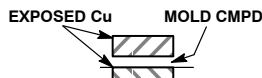

DETAIL B  
ALTERNATE  
CONSTRUCTION

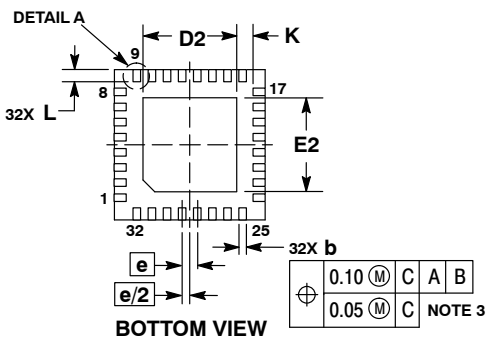

BOTTOM VIEW

NOTES:

1. DIMENSIONS AND TOLERANCING PER ASME Y14.5M, 1994.
2. CONTROLLING DIMENSION: MILLIMETERS.
3. DIMENSION b APPLIES TO PLATED TERMINAL AND IS MEASURED BETWEEN 0.15 AND 0.30MM FROM THE TERMINAL TIP.
4. COPLANARITY APPLIES TO THE EXPOSED PAD AS WELL AS THE TERMINALS.

MILLIMETERS		
DIM	MIN	MAX
A	0.80	1.00
A1	---	0.05
A3	0.20	REF
b	0.18	0.30
D	5.00	BSC
D2	2.95	3.25
E	5.00	BSC
E2	2.95	3.25
e	0.50	BSC
K	0.20	---
L	0.30	0.50
L1	---	0.15

GENERIC MARKING DIAGRAM\*

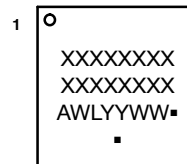

- XXXXX = Specific Device Code
- A = Assembly Location
- WL = Wafer Lot
- YY = Year
- WW = Work Week
- = Pb-Free Package

(Note: Microdot may be in either location)  
\*This information is generic. Please refer to device data sheet for actual part marking.  
Pb-Free indicator, "G" or microdot "▪", may or may not be present.

RECOMMENDED SOLDERING FOOTPRINT\*

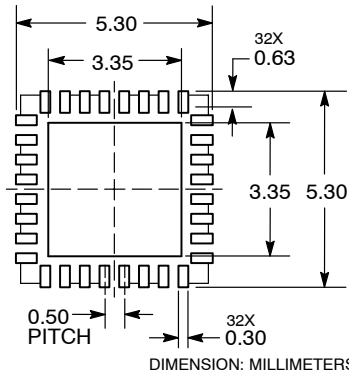

\*For additional information on our Pb-Free strategy and soldering details, please download the ON Semiconductor Soldering and Mounting Techniques Reference Manual, SOLDERRM/D.

DOCUMENT NUMBER:	98AON20032D	Electronic versions are uncontrolled except when accessed directly from the Document Repository. Printed versions are uncontrolled except when stamped "CONTROLLED COPY" in red.
DESCRIPTION:	QFN32 5x5 0.5P	PAGE 1 OF 1

ON Semiconductor and ON are trademarks of Semiconductor Components Industries, LLC dba ON Semiconductor or its subsidiaries in the United States and/or other countries. ON Semiconductor reserves the right to make changes without further notice to any products herein. ON Semiconductor makes no warranty, representation or guarantee regarding the suitability of its products for any particular purpose, nor does ON Semiconductor assume any liability arising out of the application or use of any product or circuit, and specifically disclaims any and all liability, including without limitation special, consequential or incidental damages. ON Semiconductor does not convey any license under its patent rights nor the rights of others.

**MECHANICAL CASE OUTLINE**  
**PACKAGE DIMENSIONS**

ON Semiconductor®



**LQFP-32, 7x7**  
**CASE 561AB-01**  
**ISSUE O**

DATE 19 JUN 2008

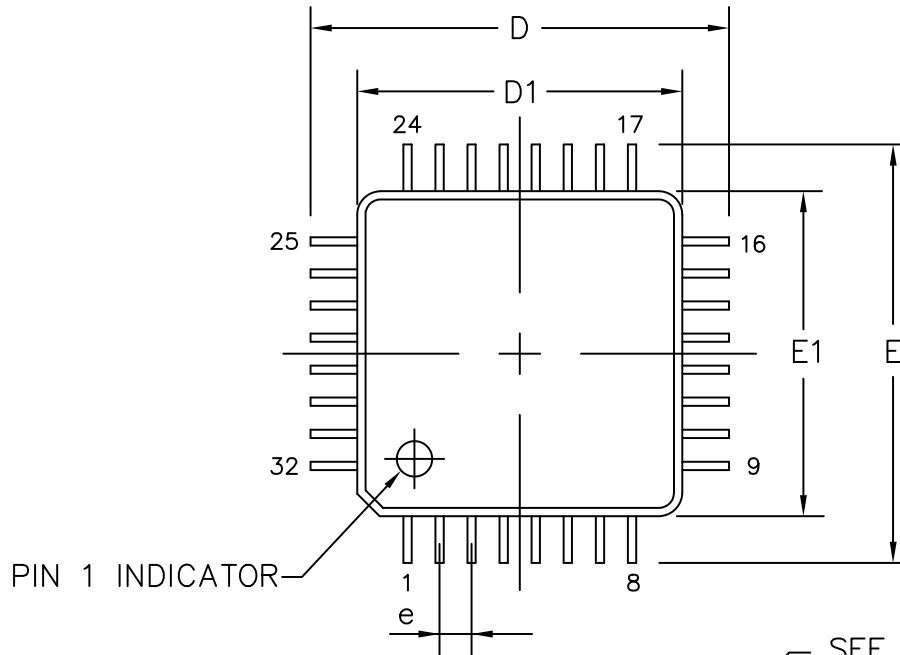

SYMBOL	MIN	NOM	MAX
A	—	—	1.60
A1	0.05	—	0.15
A2	1.35	1.40	1.45
B	0.30	0.37	0.45
B1	0.30	0.35	0.40
C	0.09	—	0.20
C1	0.09	—	0.16
D	9.00 BSC		
D1	7.00 BSC		
E	9.00 BSC		
E1	7.00 BSC		
e	0.80 BSC		
L	0.45	0.60	0.75
L1	1.00		
R1	0.08	—	0.20
$\alpha^\circ$	11	—	13
$\beta^\circ$	0	—	7
$\gamma^\circ$	0	—	—

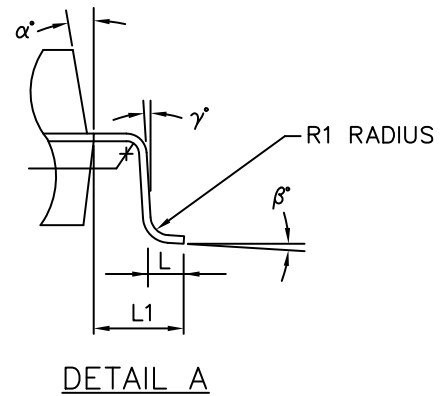
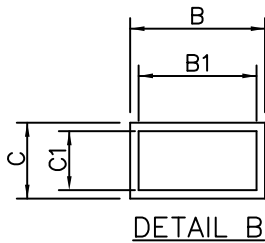
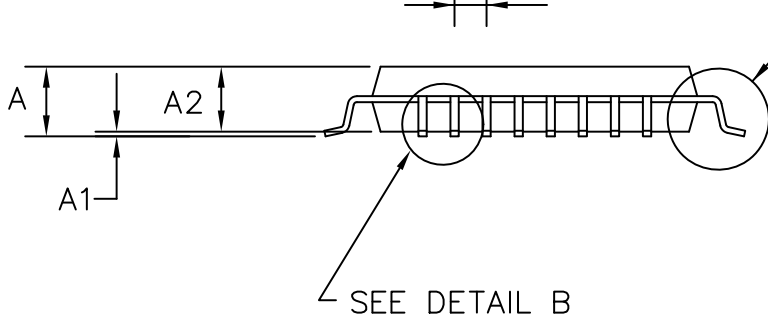

ALL DIMENSIONS IN MM

<b>DOCUMENT NUMBER:</b>	<b>98AON30893E</b>	Electronic versions are uncontrolled except when accessed directly from the Document Repository. Printed versions are uncontrolled except when stamped "CONTROLLED COPY" in red.
<b>DESCRIPTION:</b>	<b>32 LEAD LQFP, 7X7</b>	<b>PAGE 1 OF 1</b>

ON Semiconductor and are trademarks of Semiconductor Components Industries, LLC dba ON Semiconductor or its subsidiaries in the United States and/or other countries. ON Semiconductor reserves the right to make changes without further notice to any products herein. ON Semiconductor makes no warranty, representation or guarantee regarding the suitability of its products for any particular purpose, nor does ON Semiconductor assume any liability arising out of the application or use of any product or circuit, and specifically disclaims any and all liability, including without limitation special, consequential or incidental damages. ON Semiconductor does not convey any license under its patent rights nor the rights of others.

**onsemi**, **Onsemi**, and other names, marks, and brands are registered and/or common law trademarks of Semiconductor Components Industries, LLC dba "**onsemi**" or its affiliates and/or subsidiaries in the United States and/or other countries. **onsemi** owns the rights to a number of patents, trademarks, copyrights, trade secrets, and other intellectual property. A listing of **onsemi**'s product/patent coverage may be accessed at [www.onsemi.com/site/pdf/Patent-Marking.pdf](http://www.onsemi.com/site/pdf/Patent-Marking.pdf). **onsemi** reserves the right to make changes at any time to any products or information herein, without notice. The information herein is provided "as-is" and **onsemi** makes no warranty, representation or guarantee regarding the accuracy of the information, product features, availability, functionality, or suitability of its products for any particular purpose, nor does **onsemi** assume any liability arising out of the application or use of any product or circuit, and specifically disclaims any and all liability, including without limitation special, consequential or incidental damages. Buyer is responsible for its products and applications using **onsemi** products, including compliance with all laws, regulations and safety requirements or standards, regardless of any support or applications information provided by **onsemi**. "Typical" parameters which may be provided in **onsemi** data sheets and/or specifications can and do vary in different applications and actual performance may vary over time. All operating parameters, including "Typicals" must be validated for each customer application by customer's technical experts. **onsemi** does not convey any license under any of its intellectual property rights nor the rights of others. **onsemi** products are not designed, intended, or authorized for use as a critical component in life support systems or any FDA Class 3 medical devices or medical devices with a same or similar classification in a foreign jurisdiction or any devices intended for implantation in the human body. Should Buyer purchase or use **onsemi** products for any such unintended or unauthorized application, Buyer shall indemnify and hold **onsemi** and its officers, employees, subsidiaries, affiliates, and distributors harmless against all claims, costs, damages, and expenses, and reasonable attorney fees arising out of, directly or indirectly, any claim of personal injury or death associated with such unintended or unauthorized use, even if such claim alleges that **onsemi** was negligent regarding the design or manufacture of the part. **onsemi** is an Equal Opportunity/Affirmative Action Employer. This literature is subject to all applicable copyright laws and is not for resale in any manner.

## ADDITIONAL INFORMATION

### TECHNICAL PUBLICATIONS:

Technical Library: [www.onsemi.com/design/resources/technical-documentation](http://www.onsemi.com/design/resources/technical-documentation)  
onsemi Website: [www.onsemi.com](http://www.onsemi.com)

### ONLINE SUPPORT: [www.onsemi.com/support](http://www.onsemi.com/support)

For additional information, please contact your local Sales Representative at [www.onsemi.com/support/sales](http://www.onsemi.com/support/sales)

## Looking for pricing, stock, or lifecycle information?

Click below to explore more details on WIN SOURCE:

- ⊖ [View MC100LVEP111FA on WIN SOURCE](#)
- ⊖ [ON Semiconductor Information](#)

## Optimize Your Supply Chain with WIN SOURCE Solutions

- ✓ Global Sourcing Solution
- ✓ Obsolete Management
- ✓ Cost Control Management
- ✓ Shortage Management
- ✓ Alternative Solution
- ✓ Excess Inventory Management