



**THE DATASHEET OF
ADG633YCP**



FEATURES

± 2 V to ± 6 V dual-supply operation
 2 V to 12 V single-supply operation
 Temperature range: -40°C to $+125^{\circ}\text{C}$
 <0.2 nA leakage currents
 $52\ \Omega$ on resistance over full signal range
 Rail-to-rail switching operation
 16-lead LFCSP and TSSOP packages
 Typical power consumption: $<0.1\ \mu\text{W}$
 TTL-/CMOS-compatible inputs
 Package upgrades to 74HC4053 and MAX4053/MAX4583

APPLICATIONS

Automatic test equipment
 Data acquisition systems
 Battery-powered systems
 Communications systems
 Audio and video signal routing
 Relay replacement
 Sample-and-hold systems
 Industrial control systems

GENERAL DESCRIPTION

The **ADG633** is a low voltage CMOS device comprising three independently selectable single-pole, double-throw (SPDT) switches. The device is fully specified for ± 5 V, +5 V, and +3 V supplies. The **ADG633** switches are turned on with a logic low (or high) on the appropriate control input. Each switch conducts equally well in both directions when on and has an input signal range that extends to the supplies. An $\overline{\text{EN}}$ input is used to enable or disable the device. When the device is disabled, all channels are switched off.

The **ADG633** is designed on an enhanced process that provides lower power dissipation, yet is capable of high switching speeds. Low power consumption and an operating supply range of 2 V to 12 V make the **ADG633** ideal for battery-powered, portable instruments. All channels exhibit break-before-make switching action, preventing momentary shorting when switching channels.

FUNCTIONAL BLOCK DIAGRAM

Figure 1.

03275-001

All digital inputs have 0.8 V to 2.4 V logic thresholds, ensuring TTL/CMOS logic compatibility when using single +5 V or dual ± 5 V supplies.

The **ADG633** is available in a small, 16-lead TSSOP package and a 16-lead, 4 mm \times 4 mm LFCSP package.

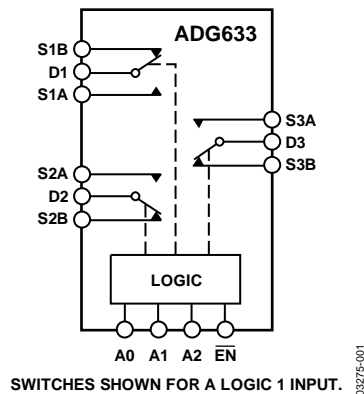
PRODUCT HIGHLIGHTS

1. Single- and dual-supply operation. The **ADG633** offers high performance and is fully specified and guaranteed with ± 5 V, +5 V, and +3 V supply rails.
2. Temperature range: -40°C to $+125^{\circ}\text{C}$.
3. Guaranteed break-before-make switching action.
4. Low power consumption, typically $<0.1\ \mu\text{W}$.
5. Small, 16-lead TSSOP and 16-lead, 4 mm \times 4 mm LFCSP packages.

TABLE OF CONTENTS

| | | | |
|--------------------------------|---|--|----|
| Features | 1 | Absolute Maximum Ratings | 6 |
| Applications..... | 1 | ESD Caution..... | 6 |
| Functional Block Diagram | 1 | Pin Configurations and Function Descriptions | 7 |
| General Description | 1 | Typical Performance Characteristics | 8 |
| Product Highlights | 1 | Terminology | 11 |
| Revision History | 2 | Test Circuits..... | 12 |
| Specifications..... | 3 | Outline Dimensions | 14 |
| Dual-Supply Operation | 3 | Ordering Guide | 14 |
| Single-Supply Operation | 4 | | |

REVISION HISTORY

2/2017—Rev. A to Rev. B

| | |
|---|------------|
| Deleted B Version | Throughout |
| Changes to Features Section, Applications Section, and Product Highlights Section | 1 |
| Added Note 2 to Table 1; Renumbered Sequentially | 3 |
| Added Note 2 to Table 2; Renumbered Sequentially | 4 |
| Added Note 2 to Table 3; Renumbered Sequentially | 5 |
| Added Note 1 to Table 4; Renumbered Sequentially | 6 |
| Changes to Figure 3 and Table 6..... | 7 |
| Updated Outline Dimensions | 14 |
| Changes to Ordering Guide | 14 |

11/2009—Rev. 0 to Rev. A

| | |
|--|----|
| Changes to Table 4..... | 6 |
| Added Table 5; Renumbered Sequentially | 7 |
| Changes to Table 6..... | 7 |
| Update Outline Dimensions | 14 |
| Changes to Ordering Guide | 14 |

2/2003—Revision 0: Initial Version

SPECIFICATIONS

DUAL-SUPPLY OPERATION

$V_{DD} = +5\text{ V}$, $V_{SS} = -5\text{ V}$, $GND = 0\text{ V}$, $T_A = -40^\circ\text{C}$ to $+125^\circ\text{C}$, unless otherwise noted.

Table 1.

| Parameter | +25°C | -40°C to +85°C | -40°C to +125°C | Unit | Test Conditions/Comments |
|--|-------------|----------------|----------------------|-------------------|--|
| ANALOG SWITCH | | | | | |
| Analog Signal Range | | | V_{SS} to V_{DD} | V | $V_{DD} = +4.5\text{ V}$, $V_{SS} = -4.5\text{ V}$ |
| On Resistance, R_{ON} | 52 | | | Ω typ | $V_S = \pm 4.5\text{ V}$, $I_S = 1\text{ mA}$; see Figure 20 |
| | 75 | 90 | 100 | Ω max | $V_S = \pm 4.5\text{ V}$, $I_S = 1\text{ mA}$; see Figure 20 |
| On-Resistance Match Between Channels, ΔR_{ON} | 0.8 | | | Ω typ | $V_S = +3.5\text{ V}$, $I_S = 1\text{ mA}$ |
| | 1.3 | 1.8 | 2 | Ω max | $V_S = +3.5\text{ V}$, $I_S = 1\text{ mA}$ |
| On-Resistance Flatness, $R_{FLAT(ON)}$ | 9 | | | Ω typ | $V_{DD} = +5\text{ V}$, $V_{SS} = -5\text{ V}$, $V_S = \pm 3\text{ V}$, $I_S = 1\text{ mA}$ |
| | 12 | 13 | 14 | Ω max | $V_{DD} = +5\text{ V}$, $V_{SS} = -5\text{ V}$, $V_S = \pm 3\text{ V}$, $I_S = 1\text{ mA}$ |
| LEAKAGE CURRENTS | | | | | |
| Source Off Leakage, $I_{S(OFF)}$ | ± 0.005 | | | nA typ | $V_{DD} = +5.5\text{ V}$, $V_{SS} = -5.5\text{ V}$ |
| | ± 0.2 | | ± 5 | nA max | $V_D = \pm 4.5\text{ V}$, $V_S = \mp 4.5\text{ V}$; see Figure 21 |
| Drain Off Leakage, $I_{D(OFF)}$ | ± 0.005 | | | nA typ | $V_D = \pm 4.5\text{ V}$, $V_S = \mp 4.5\text{ V}$; see Figure 21 |
| | ± 0.2 | | ± 5 | nA max | $V_D = \pm 4.5\text{ V}$, $V_S = \mp 4.5\text{ V}$; see Figure 22 |
| Channel On Leakage, $I_{D(ON)}$, $I_{S(ON)}$ | ± 0.005 | | | nA typ | $V_D = V_S = \pm 4.5\text{ V}$; see Figure 23 |
| | ± 0.2 | | ± 5 | nA max | $V_D = V_S = \pm 4.5\text{ V}$; see Figure 23 |
| DIGITAL INPUTS | | | | | |
| Input High Voltage, V_{INH} | | | 2.4 | V min | |
| Input Low Voltage, V_{INL} | | | 0.8 | V max | |
| Input Current, I_{INL} or I_{INH} | 0.005 | | | μA typ | $V_{IN} = V_{INL}$ or V_{INH} |
| | | | ± 1 | μA max | $V_{IN} = V_{INL}$ or V_{INH} |
| Digital Input Capacitance, C_{IN} | 2 | | | pF typ | |
| DYNAMIC CHARACTERISTICS¹ | | | | | |
| $t_{TRANSITION}$ | 60 | | | ns typ | $R_L = 300\ \Omega$, $C_L = 35\text{ pF}$, $V_S = 3\text{ V}$; see Figure 24 |
| | 90 | 110 | 130 | ns max | $R_L = 300\ \Omega$, $C_L = 35\text{ pF}$, $V_S = 3\text{ V}$; see Figure 24 |
| $t_{ON}(\overline{EN})$ | 70 | | | ns typ | $R_L = 300\ \Omega$, $C_L = 35\text{ pF}$, $V_S = 3\text{ V}$; see Figure 26 |
| | 95 | 120 | 135 | ns max | $R_L = 300\ \Omega$, $C_L = 35\text{ pF}$, $V_S = 3\text{ V}$; see Figure 26 |
| $t_{OFF}(\overline{EN})$ | 25 | | | ns typ | $R_L = 300\ \Omega$, $C_L = 35\text{ pF}$, $V_S = 3\text{ V}$; see Figure 26 |
| | 40 | 45 | 50 | ns max | $R_L = 300\ \Omega$, $C_L = 35\text{ pF}$, $V_S = 3\text{ V}$; see Figure 26 |
| Break-Before-Make Time Delay, t_{BBM} | 40 | | | ns typ | $R_L = 300\ \Omega$, $C_L = 35\text{ pF}$, $V_{S1} = V_{S2} = 3\text{ V}$; see Figure 25 |
| | | | 10 | ns min | $R_L = 300\ \Omega$, $C_L = 35\text{ pF}$, $V_{S1} = V_{S2} = 3\text{ V}$; see Figure 25 |
| Charge Injection | 2 | | | pC typ | $V_S = 0\text{ V}$, $R_S = 0\ \Omega$, $C_L = 1\text{ nF}$; see Figure 27 |
| | 4 | | | pC max | $V_S = 0\text{ V}$, $R_S = 0\ \Omega$, $C_L = 1\text{ nF}$; see Figure 27 |
| Off Isolation | -90 | | | dB typ | $R_L = 50\ \Omega$, $C_L = 5\text{ pF}$, $f = 1\text{ MHz}$; see Figure 28 |
| Total Harmonic Distortion, THD + N | 0.025 | | | % typ | $R_L = 600\ \Omega$, 2 V p-p , $f = 20\text{ Hz}$ to 20 kHz |
| Channel-to-Channel Crosstalk | -90 | | | dB typ | $R_L = 50\ \Omega$, $C_L = 5\text{ pF}$, $f = 1\text{ MHz}$; see Figure 30 |
| -3 dB Bandwidth | 580 | | | MHz typ | $R_L = 50\ \Omega$, $C_L = 5\text{ pF}$; see Figure 29 |
| $C_{S(OFF)}$ | 4 | | | pF typ | $f = 1\text{ MHz}$ |
| $C_{D(OFF)}$ | 7 | | | pF typ | $f = 1\text{ MHz}$ |
| $C_{D(ON)}$, $C_{S(ON)}$ | 12 | | | pF typ | $f = 1\text{ MHz}$ |
| POWER REQUIREMENTS² | | | | | |
| I_{DD} | 0.01 | | | μA typ | $V_{DD} = +5.5\text{ V}$, $V_{SS} = -5.5\text{ V}$ |
| | | | 1 | μA max | Digital inputs = 0 V or 5.5 V |
| I_{SS} | 0.01 | | | μA typ | Digital inputs = 0 V or 5.5 V |
| | | | 1 | μA max | Digital inputs = 0 V or 5.5 V |

¹ Guaranteed by design; not subject to production test.

² The device is fully specified at a $\pm 5\text{ V}$ dual supply and at 5 V and 3.3 V single supplies. It is possible to operate the ADG633 with unbalanced supplies or at other voltage supplies ($\pm 2\text{ V}$ to $\pm 6\text{ V}$, and 2 V to 12 V); however, the switch characteristics change. These changes include, but are not limited to: analog signal range, on resistance, leakage, V_{INL} , V_{INH} , and switching times. The optimal power-up sequence for the device is: ground, V_{DD} , V_{SS} , and then the digital inputs, before applying the analog input signal.

SINGLE-SUPPLY OPERATION

$V_{DD} = 5\text{ V}$, $V_{SS} = 0\text{ V}$, $GND = 0\text{ V}$, $T_A = -40^\circ\text{C}$ to $+125^\circ\text{C}$, unless otherwise noted.

Table 2.

| Parameter | +25°C | -40°C to +85°C | -40°C to +125°C | Unit | Test Conditions/Comments |
|---|-------------|----------------|-----------------|------------------------------|--|
| ANALOG SWITCH | | | | | |
| Analog Signal Range | | | 0 to V_{DD} | V | $V_{DD} = 4.5\text{ V}$, $V_{SS} = 0\text{ V}$ |
| On Resistance, R_{ON} | 85 | 160 | 200 | Ω typ Ω max | $V_S = 0\text{ V}$ to 4.5 V , $I_S = 1\text{ mA}$; see Figure 20 |
| On-Resistance Match Between Channels, ΔR_{ON} | 4.5 | | | Ω typ | $V_S = 0\text{ V}$ to 4.5 V , $I_S = 1\text{ mA}$; see Figure 20 |
| On-Resistance Flatness, $R_{FLAT(ON)}$ | 8 | 9 | 10 | Ω max | $V_S = +3.5\text{ V}$, $I_S = 1\text{ mA}$ |
| | 13 | 14 | 16 | Ω typ | $V_{DD} = 5\text{ V}$, $V_{SS} = 0\text{ V}$, $V_S = 1.5\text{ V}$ to 4 V , $I_S = 1\text{ mA}$ |
| LEAKAGE CURRENTS | | | | | |
| Source Off Leakage, $I_{S(OFF)}$ | ± 0.005 | | | nA typ | $V_{DD} = 5.5\text{ V}$ |
| | ± 0.2 | | ± 5 | nA max | $V_S = 1\text{ V}/4.5\text{ V}$, $V_D = 4.5\text{ V}/1\text{ V}$; see Figure 21 |
| Drain Off Leakage, $I_{D(OFF)}$ | ± 0.005 | | | nA typ | $V_S = 1\text{ V}/4.5\text{ V}$, $V_D = 4.5\text{ V}/1\text{ V}$; see Figure 21 |
| | ± 0.2 | | ± 5 | nA max | $V_S = 1\text{ V}/4.5\text{ V}$, $V_D = 4.5\text{ V}/1\text{ V}$; see Figure 22 |
| Channel On Leakage, $I_{D(ON)}$, $I_{S(ON)}$ | ± 0.005 | | | nA typ | $V_S = V_D = 1\text{ V}$ or 4.5 V ; see Figure 23 |
| | ± 0.2 | | ± 5 | nA max | $V_S = V_D = 1\text{ V}$ or 4.5 V ; see Figure 23 |
| DIGITAL INPUTS | | | | | |
| Input High Voltage, V_{INH} | | | 2.4 | V min | |
| Input Low Voltage, V_{INL} | | | 0.8 | V max | |
| Input Current, I_{INL} or I_{INH} | 0.005 | | | μA typ | $V_{IN} = V_{INL}$ or V_{INH} |
| | | | ± 1 | μA max | $V_{IN} = V_{INL}$ or V_{INH} |
| Digital Input Capacitance, C_{IN} | 2 | | | pF typ | |
| DYNAMIC CHARACTERISTICS¹ | | | | | |
| $t_{TRANSITION}$ | 100 | | | ns typ | $R_L = 300\ \Omega$, $C_L = 35\text{ pF}$, $V_S = 3\text{ V}$; see Figure 24 |
| | 150 | 190 | 220 | ns max | $R_L = 300\ \Omega$, $C_L = 35\text{ pF}$, $V_S = 3\text{ V}$; see Figure 24 |
| $t_{ON}(\overline{EN})$ | 100 | | | ns typ | $R_L = 300\ \Omega$, $C_L = 35\text{ pF}$, $V_S = 3\text{ V}$; see Figure 26 |
| | 150 | 190 | 220 | ns max | $R_L = 300\ \Omega$, $C_L = 35\text{ pF}$, $V_S = 3\text{ V}$; see Figure 26 |
| $t_{OFF}(\overline{EN})$ | 25 | | | ns typ | $R_L = 300\ \Omega$, $C_L = 35\text{ pF}$, $V_S = 3\text{ V}$; see Figure 26 |
| | 35 | 45 | 50 | ns max | $R_L = 300\ \Omega$, $C_L = 35\text{ pF}$, $V_S = 3\text{ V}$; see Figure 26 |
| Break-Before-Make Time Delay, t_{BBM} | 90 | | | ns typ | $R_L = 300\ \Omega$, $C_L = 35\text{ pF}$, $V_{S1} = V_{S2} = 3\text{ V}$; see Figure 25 |
| | | | 10 | ns min | $R_L = 300\ \Omega$, $C_L = 35\text{ pF}$, $V_{S1} = V_{S2} = 3\text{ V}$; see Figure 25 |
| Charge Injection | 0.5 | | | pC typ | $V_S = 2.5\text{ V}$, $R_S = 0\ \Omega$, $C_L = 1\text{ nF}$; see Figure 27 |
| | 1 | | | pC max | $V_S = 2.5\text{ V}$, $R_S = 0\ \Omega$, $C_L = 1\text{ nF}$; see Figure 27 |
| Off Isolation | -90 | | | dB typ | $R_L = 50\ \Omega$, $C_L = 5\text{ pF}$, $f = 1\text{ MHz}$; see Figure 28 |
| Channel-to-Channel Crosstalk | -90 | | | dB typ | $R_L = 50\ \Omega$, $C_L = 5\text{ pF}$, $f = 1\text{ MHz}$; see Figure 30 |
| -3 dB Bandwidth | 520 | | | MHz typ | $R_L = 50\ \Omega$, $C_L = 5\text{ pF}$; see Figure 29 |
| $C_{S(OFF)}$ | 5 | | | pF typ | $f = 1\text{ MHz}$ |
| $C_{D(OFF)}$ | 8 | | | pF typ | $f = 1\text{ MHz}$ |
| $C_{D(ON)}$, $C_{S(ON)}$ | 12 | | | pF typ | $f = 1\text{ MHz}$ |
| POWER REQUIREMENTS² | | | | | |
| I_{DD} | 0.01 | | | μA typ | $V_{DD} = 5.5\text{ V}$ |
| | | | 1 | μA max | Digital inputs = 0 V or 5.5 V |

¹ Guaranteed by design; not subject to production test.

² The device is fully specified at a $\pm 5\text{ V}$ dual supply and at 5 V and 3.3 V single supplies. It is possible to operate the ADG633 with unbalanced supplies or at other voltage supplies ($\pm 2\text{ V}$ to $\pm 6\text{ V}$, and 2 V to 12 V); however, the switch characteristics change. These changes include, but are not limited to: analog signal range, on resistance, leakage, V_{INL} , V_{INH} , and switching times. The optimal power-up sequence for the device is: ground, V_{DD} , V_{SS} , and then the digital inputs, before applying the analog input signal.

$V_{DD} = 2.7 \text{ V to } 3.6 \text{ V}$, $V_{SS} = 0 \text{ V}$, $GND = 0 \text{ V}$, $T_A = -40^\circ\text{C to } +125^\circ\text{C}$, unless otherwise noted.

Table 3.

| Parameter | +25°C | -40°C to +85°C | -40°C to +125°C | Unit | Test Conditions/Comments |
|--|-------------|----------------|-----------------|-------------------|--|
| ANALOG SWITCH | | | | | |
| Analog Signal Range | | | 0 to V_{DD} | V | $V_{DD} = 2.7 \text{ V}$, $V_{SS} = 0 \text{ V}$ |
| On Resistance, R_{ON} | 185 | | | Ω typ | $V_S = 0 \text{ V to } 2.7 \text{ V}$, $I_S = 0.1 \text{ mA}$; see Figure 20 |
| | 300 | 350 | 400 | Ω max | $V_S = 0 \text{ V to } 2.7 \text{ V}$, $I_S = 0.1 \text{ mA}$; see Figure 20 |
| On-Resistance Match Between Channels, ΔR_{ON} | 2 | | | Ω typ | $V_S = +1.5 \text{ V}$, $I_S = 0.1 \text{ mA}$ |
| | 4.5 | 6 | 7 | Ω max | $V_S = +1.5 \text{ V}$, $I_S = 0.1 \text{ mA}$ |
| LEAKAGE CURRENTS | | | | | |
| Source Off Leakage, $I_{S(OFF)}$ | ± 0.005 | | | nA typ | $V_{DD} = 3.3 \text{ V}$ |
| | ± 0.2 | | ± 5 | nA max | $V_S = 1 \text{ V/3 V}$, $V_D = 3 \text{ V/1 V}$; see Figure 21 |
| Drain Off Leakage, $I_{D(OFF)}$ | ± 0.005 | | | nA typ | $V_S = 1 \text{ V/3 V}$, $V_D = 3 \text{ V/1 V}$; see Figure 21 |
| | ± 0.2 | | ± 5 | nA max | $V_S = 1 \text{ V/3 V}$, $V_D = 3 \text{ V/1 V}$; see Figure 22 |
| Channel On Leakage, $I_{D(ON)}$, $I_{S(ON)}$ | ± 0.005 | | | nA typ | $V_S = V_D = 1 \text{ V or } 3 \text{ V}$; see Figure 23 |
| | ± 0.2 | | ± 5 | nA max | $V_S = V_D = 1 \text{ V or } 3 \text{ V}$; see Figure 23 |
| DIGITAL INPUTS | | | | | |
| Input High Voltage, V_{INH} | | | 2.0 | V min | |
| Input Low Voltage, V_{INL} | | | 0.5 | V max | |
| Input Current, I_{INL} or I_{INH} | 0.005 | | | μA typ | $V_{IN} = V_{INL}$ or V_{INH} |
| | | | ± 1 | μA max | $V_{IN} = V_{INL}$ or V_{INH} |
| Digital Input Capacitance, C_{IN} | 2 | | | pF typ | |
| DYNAMIC CHARACTERISTICS¹ | | | | | |
| $t_{TRANSITION}$ | 170 | | | ns typ | $R_L = 300 \Omega$, $C_L = 35 \text{ pF}$, $V_S = 1.5 \text{ V}$; see Figure 24 |
| | 300 | 370 | 400 | ns max | $R_L = 300 \Omega$, $C_L = 35 \text{ pF}$, $V_S = 1.5 \text{ V}$; see Figure 24 |
| $t_{ON}(\overline{EN})$ | 200 | | | ns typ | $R_L = 300 \Omega$, $C_L = 35 \text{ pF}$, $V_S = 1.5 \text{ V}$; see Figure 26 |
| | 310 | 380 | 420 | ns max | $R_L = 300 \Omega$, $C_L = 35 \text{ pF}$, $V_S = 1.5 \text{ V}$; see Figure 26 |
| $t_{OFF}(\overline{EN})$ | 30 | | | ns typ | $R_L = 300 \Omega$, $C_L = 35 \text{ pF}$, $V_S = 1.5 \text{ V}$; see Figure 26 |
| | 40 | 55 | 75 | ns max | $R_L = 300 \Omega$, $C_L = 35 \text{ pF}$, $V_S = 1.5 \text{ V}$; see Figure 26 |
| Break-Before-Make Time Delay, t_{BBM} | 180 | | | ns typ | $R_L = 300 \Omega$, $C_L = 35 \text{ pF}$, $V_{S1} = V_{S2} = 1.5 \text{ V}$; see Figure 25 |
| | | | 10 | ns min | $R_L = 300 \Omega$, $C_L = 35 \text{ pF}$, $V_{S1} = V_{S2} = 1.5 \text{ V}$; see Figure 25 |
| Charge Injection | 1 | | | pC typ | $V_S = 1.5 \text{ V}$, $R_S = 0 \Omega$, $C_L = 1 \text{ nF}$; see Figure 27 |
| | 2 | | | pC max | $V_S = 1.5 \text{ V}$, $R_S = 0 \Omega$, $C_L = 1 \text{ nF}$; see Figure 27 |
| Off Isolation | -90 | | | dB typ | $R_L = 50 \Omega$, $C_L = 5 \text{ pF}$, $f = 1 \text{ MHz}$; see Figure 28 |
| Channel-to-Channel Crosstalk | -90 | | | dB typ | $R_L = 50 \Omega$, $C_L = 5 \text{ pF}$, $f = 1 \text{ MHz}$; see Figure 30 |
| -3 dB Bandwidth | 500 | | | MHz typ | $R_L = 50 \Omega$, $C_L = 5 \text{ pF}$; see Figure 29 |
| $C_{S(OFF)}$ | 5 | | | pF typ | $f = 1 \text{ MHz}$ |
| $C_{D(OFF)}$ | 8 | | | pF typ | $f = 1 \text{ MHz}$ |
| $C_{D(ON)}$, $C_{S(ON)}$ | 12 | | | pF typ | $f = 1 \text{ MHz}$ |
| POWER REQUIREMENTS² | | | | | |
| I_{DD} | 0.01 | | | μA typ | $V_{DD} = 3.3 \text{ V}$ |
| | | | 1 | μA max | Digital inputs = 0 V or 3.3 V |
| | | | | | Digital inputs = 0 V or 3.3 V |

¹ Guaranteed by design; not subject to production test.

² The device is fully specified at a $\pm 5 \text{ V}$ dual supply and at 5 V and 3.3 V single supplies. It is possible to operate the ADG633 with unbalanced supplies or at other voltage supplies ($\pm 2 \text{ V to } \pm 6 \text{ V}$, and 2 V to 12 V); however, the switch characteristics change. These changes include, but are not limited to: analog signal range, on resistance, leakage, V_{INL} , V_{INH} , and switching times. The optimal power-up sequence for the device is: ground, V_{DD} , V_{SS} , and then the digital inputs, before applying the analog input signal.

ABSOLUTE MAXIMUM RATINGS

$T_A = 25^\circ\text{C}$, unless otherwise noted.

Table 4.

| Parameter | Rating |
|---------------------------------------|---|
| V_{DD} to V_{SS} ¹ | 13 V |
| V_{DD} to GND | -0.3 V to +13 V |
| V_{SS} to GND | +0.3 V to -6.5 V |
| Analog Inputs ² | $V_{SS} - 0.3\text{ V}$ to $V_{DD} + 0.3\text{ V}$ |
| Digital Inputs ² | GND - 0.3 V to $V_{DD} + 0.3\text{ V}$ or 10 mA, whichever occurs first |
| Peak Current, S or D | 40 mA (pulsed at 1 ms, 10% duty cycle maximum) |
| Continuous Current, S or D | 20 mA |
| Operating Temperature Range | -40°C to +125°C |
| Storage Temperature Range | -65°C to +150°C |
| Junction Temperature | 150°C |
| θ_{JA} Thermal Impedance | |
| 16-Lead TSSOP | 150.4°C/W |
| 16-Lead LFCSF, 4-Layer Board | 70°C/W |
| Lead Soldering | |
| Lead Temperature, Soldering (10 sec) | 300°C |
| IR Reflow, Peak Temperature (<20 sec) | 220°C |
| (Pb-Free) Soldering | |
| Reflow, Peak Temperature | 260(+0/-5)°C |
| Time at Peak Temperature | 20 sec to 40 sec |
| ESD | 4 kV |

¹ The device is fully specified at a $\pm 5\text{ V}$ dual supply and at 5 V and 3.3 V single supplies. It is possible to operate the ADG633 with unbalanced supplies or at other voltage supplies ($\pm 2\text{ V}$ to $\pm 6\text{ V}$, and 2 V to 12 V); however, the switch characteristics change. These changes include, but are not limited to: analog signal range, on resistance, leakage, V_{INL} , V_{INH} , and switching times. The optimal power-up sequence for the device is: ground, V_{DD} , V_{SS} , and then the digital inputs, before applying the analog input signal.

² Overvoltages at AX, EN, S, or D are clamped by internal diodes. Limit current to the maximum ratings given.

Stresses at or above those listed under Absolute Maximum Ratings may cause permanent damage to the product. This is a stress rating only; functional operation of the product at these or any other conditions above those indicated in the operational section of this specification is not implied. Operation beyond the maximum operating conditions for extended periods may affect product reliability.

Only one absolute maximum rating can be applied at any one time.

ESD CAUTION



ESD (electrostatic discharge) sensitive device. Charged devices and circuit boards can discharge without detection. Although this product features patented or proprietary protection circuitry, damage may occur on devices subjected to high energy ESD. Therefore, proper ESD precautions should be taken to avoid performance degradation or loss of functionality.

PIN CONFIGURATIONS AND FUNCTION DESCRIPTIONS

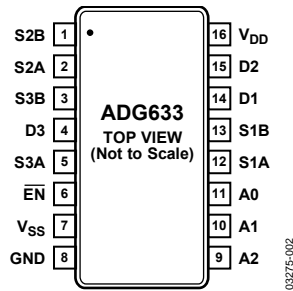
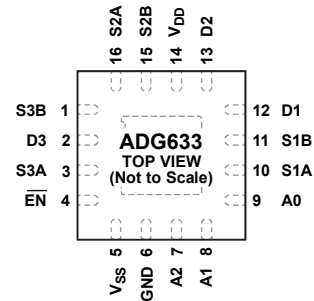

Figure 2. 16-Lead TSSOP Pin Configuration



NOTES
 1. THE EXPOSED PADDLE CAN BE LEFT FLOATING OR BE TIED TO V_{DD}, V_{SS}, OR GND.

Figure 3. 16-Lead LFCSP Pin Configuration

Table 5. Pin Function Descriptions

| Pin No. | | Mnemonic | Description |
|----------------|-------|-----------------|---|
| TSSOP | LFCSP | | |
| 1 | 15 | S2B | Source Terminal of Multiplexer 2. Can be an input or output. |
| 2 | 16 | S2A | Source Terminal of Multiplexer 2. Can be an input or output. |
| 3 | 1 | S3B | Source Terminal of Multiplexer 3. Can be an input or output. |
| 4 | 2 | D3 | Drain Terminal of Multiplexer 3. Can be an input or output. |
| 5 | 3 | S3A | Source Terminal of Multiplexer 3. Can be an input or output. |
| 6 | 4 | EN | Digital Control Input. Disables all multiplexers when set high. |
| 7 | 5 | V _{SS} | Most Negative Power Supply Terminal. Tie this pin to GND when using the device with single-supply voltages. |
| 8 | 6 | GND | Ground (0 V) Reference. |
| 9 | 7 | A2 | Digital Control Input. |
| 10 | 8 | A1 | Digital Control Input. |
| 11 | 9 | A0 | Digital Control Input. |
| 12 | 10 | S1A | Source Terminal of Multiplexer 1. Can be an input or output. |
| 13 | 11 | S1B | Source Terminal of Multiplexer 1. Can be an input or output. |
| 14 | 12 | D1 | Drain Terminal of Multiplexer 1. Can be an input or output. |
| 15 | 13 | D2 | Drain Terminal of Multiplexer 2. Can be an input or output. |
| 16 | 14 | V _{DD} | Most Positive Power Supply Terminal. |
| Not applicable | EP | EP | Exposed Paddle. The exposed paddle can be left floating or be tied to V _{DD} , V _{SS} , or GND. |

Table 6. ADG633 Truth Table

| A2 | A1 | A0 | EN | Switch Condition | | | | | |
|----------------|----------------|----------------|----|------------------|---------------|---------------|---------------|---------------|---------------|
| | | | | Switch S1A/D1 | Switch S1B/D1 | Switch S2A/D2 | Switch S2B/D2 | Switch S3A/D3 | Switch S3B/D3 |
| X ¹ | X ¹ | X ¹ | 1 | Off | Off | Off | Off | Off | Off |
| 0 | 0 | 0 | 0 | On | Off | On | Off | On | Off |
| 0 | 0 | 1 | 0 | Off | On | On | Off | On | Off |
| 0 | 1 | 0 | 0 | On | Off | Off | On | On | Off |
| 0 | 1 | 1 | 0 | Off | On | Off | On | On | Off |
| 1 | 0 | 0 | 0 | On | Off | On | Off | Off | On |
| 1 | 0 | 1 | 0 | Off | On | On | Off | Off | On |
| 1 | 1 | 0 | 0 | On | Off | Off | On | Off | On |
| 1 | 1 | 1 | 0 | Off | On | Off | On | Off | On |

¹ X means the logic state does not matter; it can be either 0 or 1.

TYPICAL PERFORMANCE CHARACTERISTICS

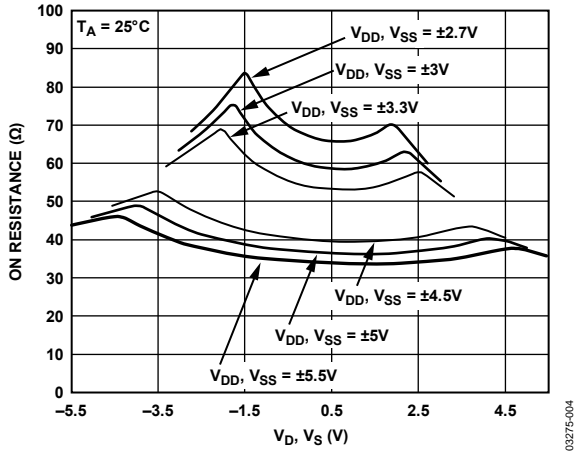

Figure 4. On Resistance vs. V_D (V_S), Dual Supplies

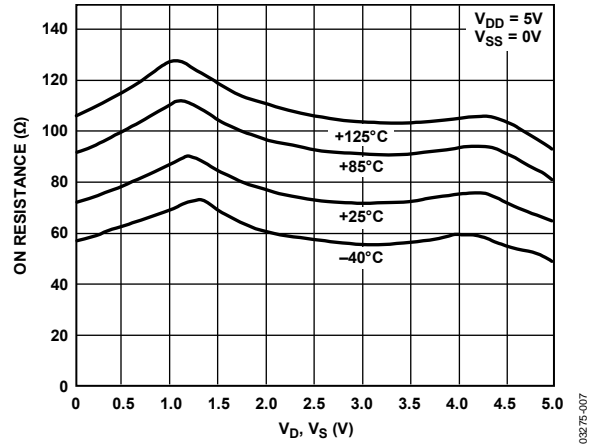

Figure 7. On Resistance vs. V_D (V_S) for Various Temperatures, Single Supply

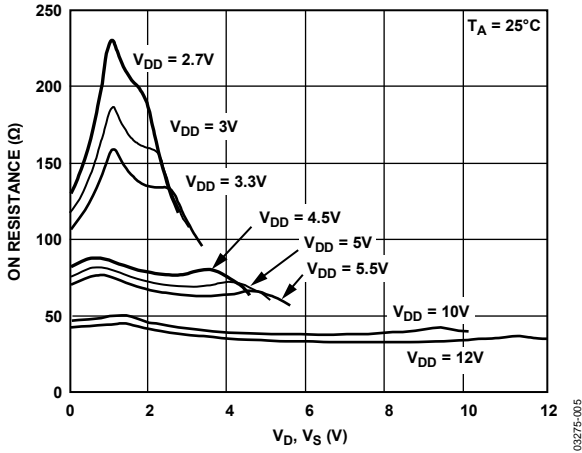

Figure 5. On Resistance vs. V_D (V_S), Single Supply

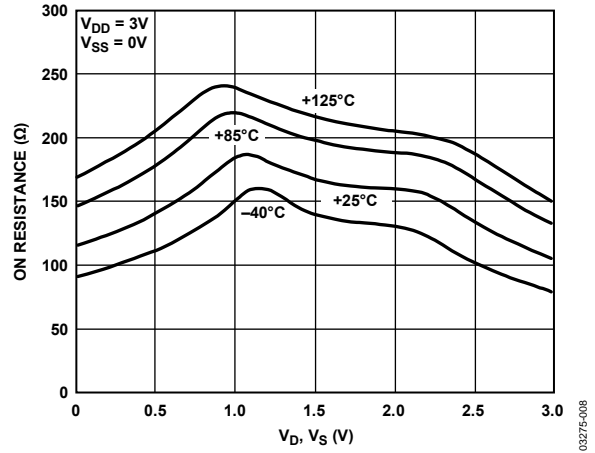

Figure 8. On Resistance vs. V_D (V_S) for Various Temperatures, Single Supply

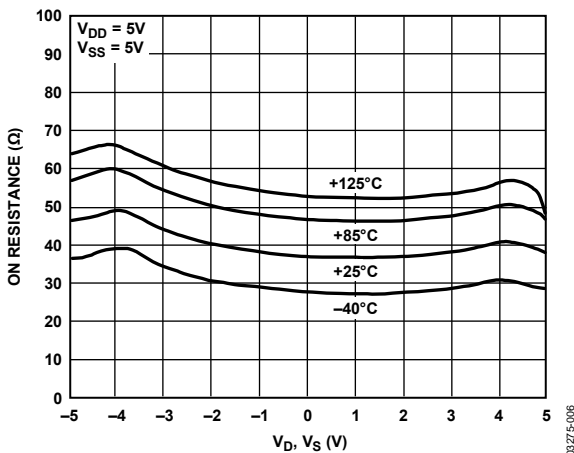

Figure 6. On Resistance vs. V_D (V_S) for Various Temperatures, Dual Supplies

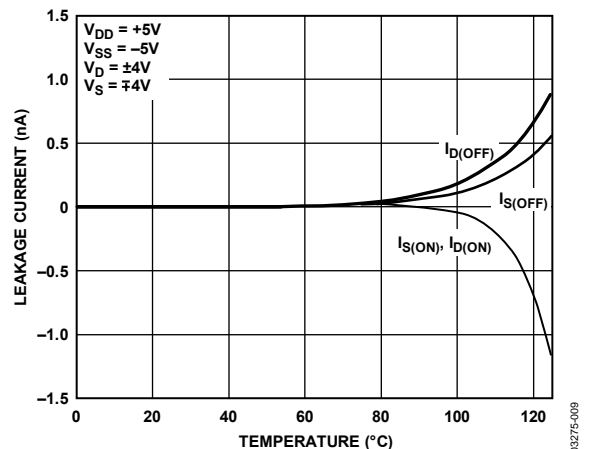

Figure 9. Leakage Current vs. Temperature, Dual Supplies

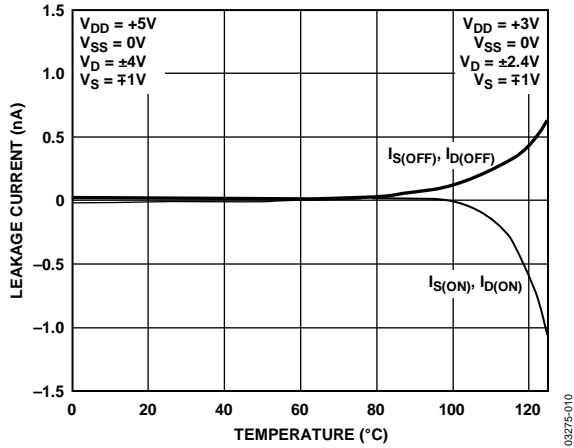

Figure 10. Leakage Current vs. Temperature, Single Supply

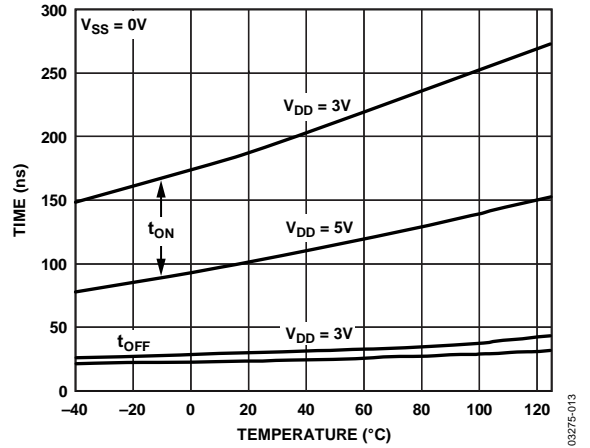

Figure 13. t_{ON}/t_{OFF} Times vs. Temperature, Single Supply

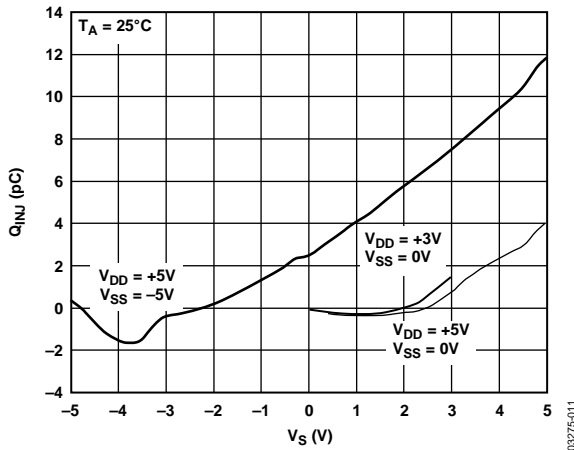

Figure 11. Charge Injection vs. Source Voltage

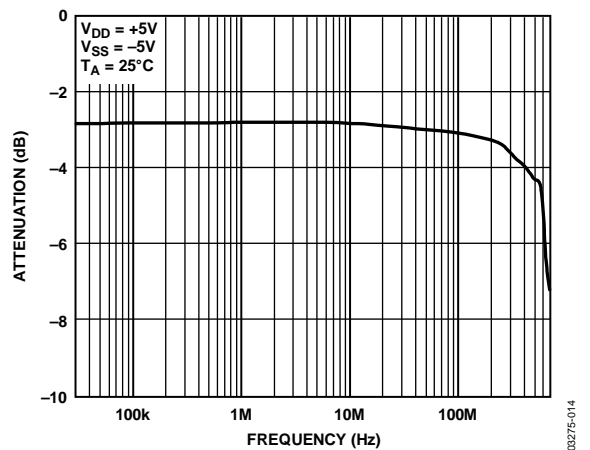

Figure 14. On Response vs. Frequency

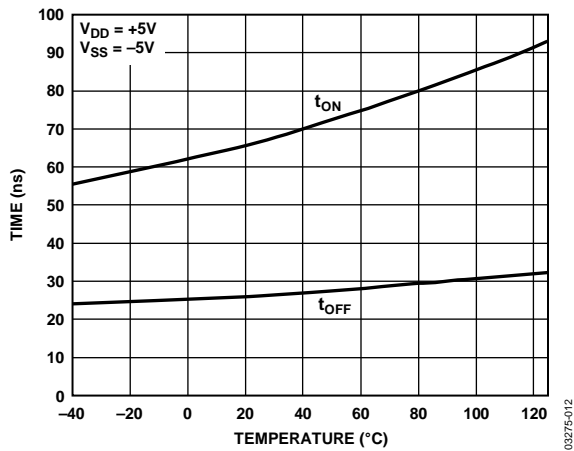

Figure 12. t_{ON}/t_{OFF} Times vs. Temperature, Dual Supplies

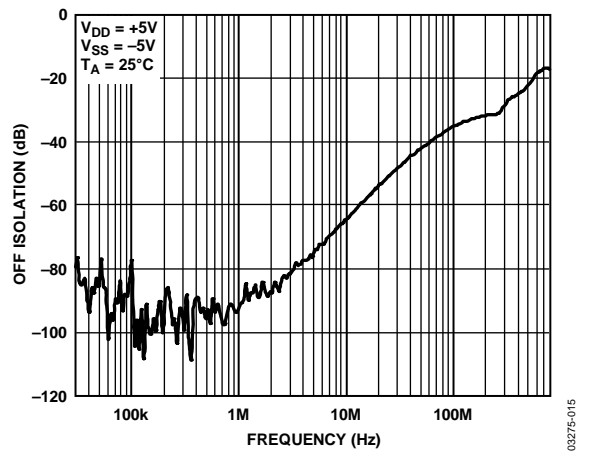

Figure 15. Off Isolation vs. Frequency

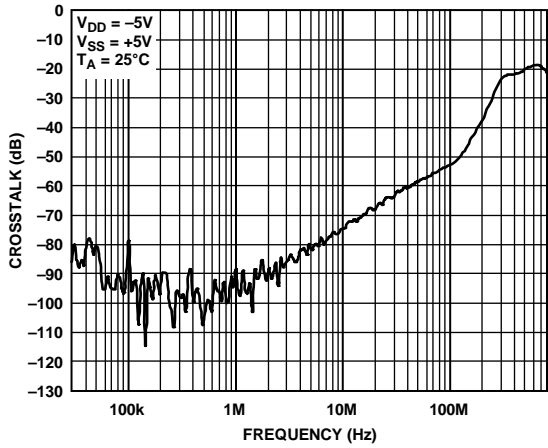

Figure 16. Crosstalk vs. Frequency

03275-016

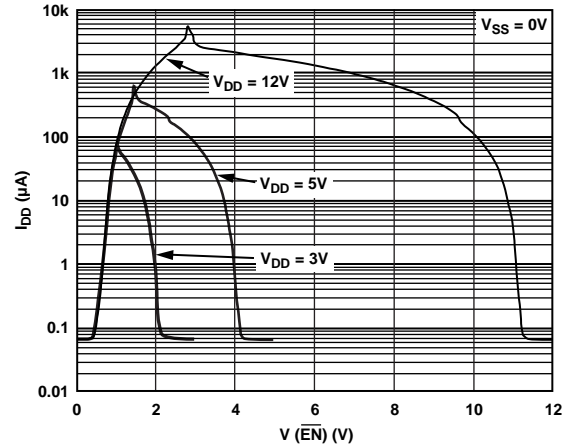

Figure 18. V_{DD} Current vs. Logic Level

03275-018

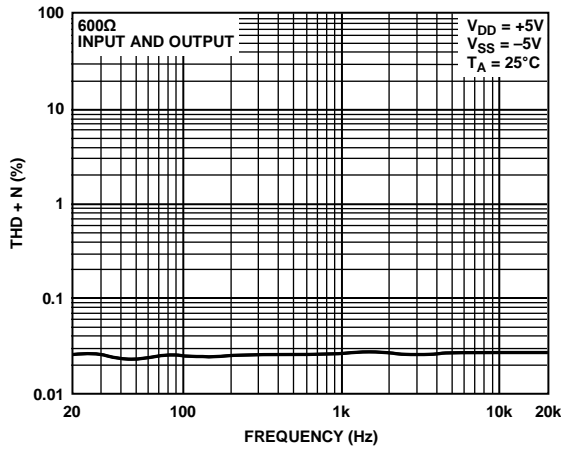

Figure 17. THD + Noise vs. Frequency

03275-017

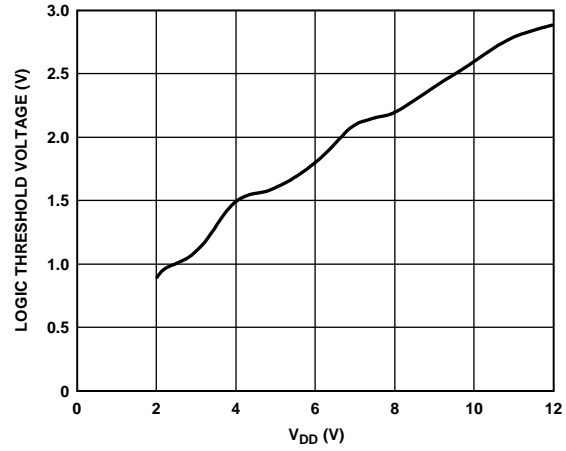

Figure 19. Logic Threshold Voltage vs. V_{DD}

03275-019

TERMINOLOGY

V_{DD}

Most positive power supply potential.

V_{SS}

Most negative power supply potential.

I_{DD}

Positive supply current.

I_{SS}

Negative supply current.

GND

Ground (0 V) reference.

S

Source terminal. Can be an input or output.

D

Drain terminal. Can be an input or output.

A_x

Logic control input.

\overline{EN}

Active low digital input. When \overline{EN} is high, the device is disabled and all switches are off. When \overline{EN} is low, the A_x logic inputs determine the on switches.

V_D, V_S

Analog voltage on Terminal D and Terminal S.

R_{ON}

Ohmic resistance between Terminal D and Terminal S.

ΔR_{ON}

On-resistance match between any two channels, that is,

$R_{ONMAX} - R_{ONMIN}$.

$R_{FLAT(ON)}$

Flatness is defined as the difference between the maximum and minimum value of on resistance as measured over the specified analog signal range.

$I_{S(OFF)}$

Source leakage current with the switch off.

$I_{D(OFF)}$

Drain leakage current with the switch off.

$I_{D(ON)}, I_{S(ON)}$

Channel leakage current with the switch on.

V_{INL}

Maximum input voltage for Logic 0.

V_{INH}

Minimum input voltage for Logic 1.

I_{INL}, I_{INH}

Input current of the digital input.

$C_{S(OFF)}$

Off switch source capacitance. Measured with reference to ground.

$C_{D(OFF)}$

Off switch drain capacitance. Measured with reference to ground.

$C_{D(ON)}, C_{S(ON)}$

On switch capacitance. Measured with reference to ground.

C_{IN}

Digital input capacitance.

$t_{ON}(\overline{EN})$

Delay between applying the digital control input and the output switching on (see Figure 26).

$t_{OFF}(\overline{EN})$

Delay between applying the digital control input and the output switching off (see Figure 26).

t_{BBM}

On time, measured between 80% points of both switches when switching from one address state to another.

Charge Injection

A measure of the glitch impulse transferred from the digital input to the analog output during switching.

Off Isolation

A measure of unwanted signal coupling through an off switch.

Crosstalk

A measure of unwanted signal that is coupled through from one channel to another as a result of parasitic capacitance.

Bandwidth

The frequency at which the output is attenuated by 3 dB.

On Response

The frequency response of the on switch.

Insertion Loss

The loss due to the on resistance of the switch.

TEST CIRCUITS

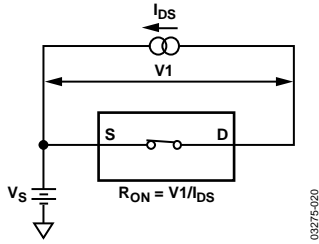

Figure 20. On Resistance

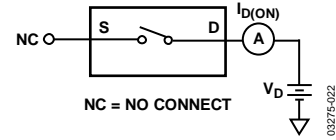

Figure 22. Drain Off Leakage

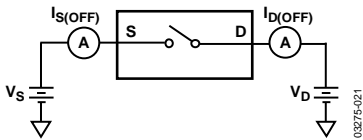

Figure 21. Source Off Leakage

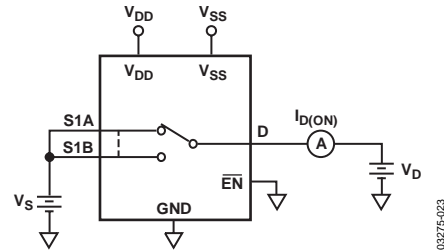

Figure 23. Channel On Leakage

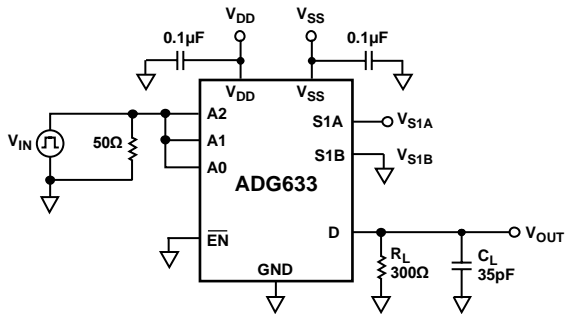

Figure 24. Transition Time, $t_{TRANSITION}$

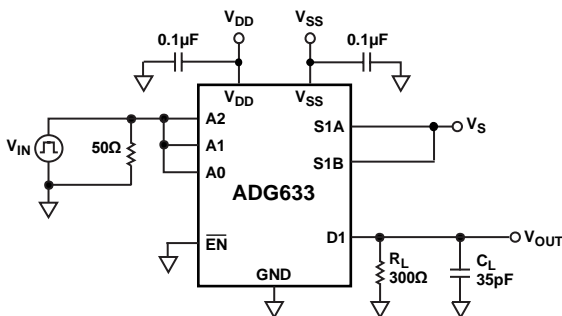
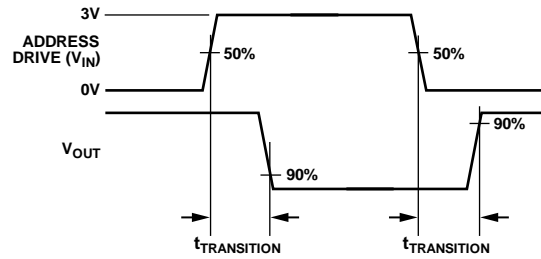
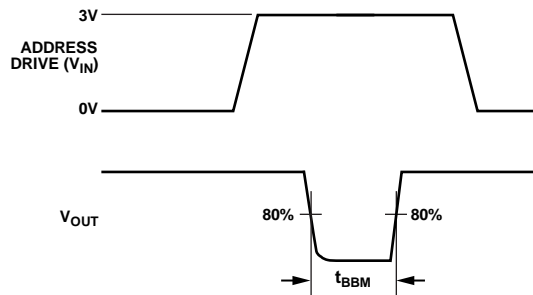

Figure 25. Break-Before-Make Delay, t_{BBM}



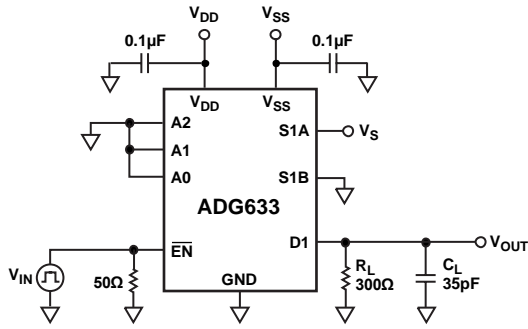
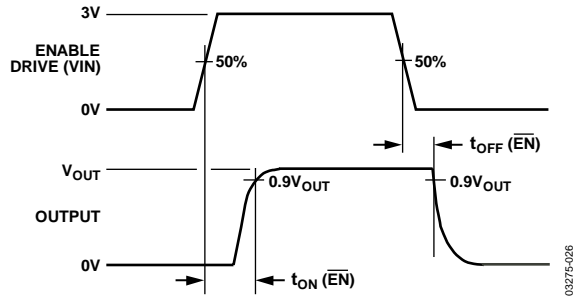

Figure 26. Enable Delay, $t_{ON}(\overline{EN})$, $t_{OFF}(\overline{EN})$



03275-026

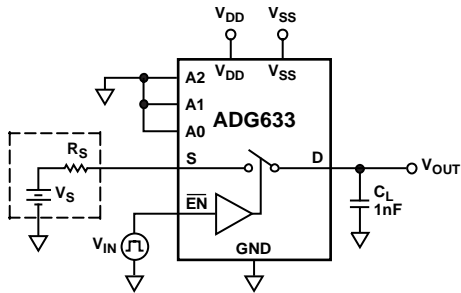
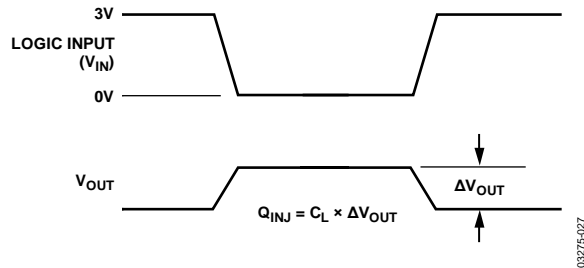

Figure 27. Charge Injection



03275-027

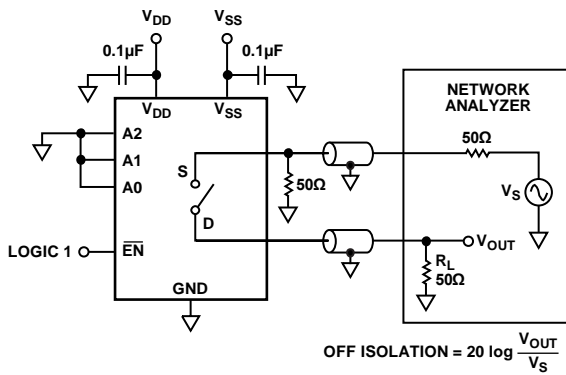

Figure 28. Off Isolation

$$\text{OFF ISOLATION} = 20 \log \frac{V_{OUT}}{V_S}$$

03275-028

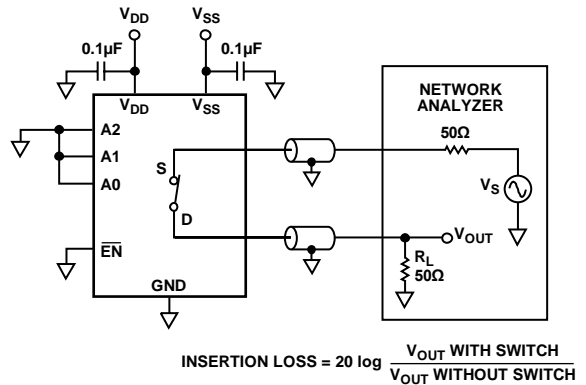

Figure 29. Bandwidth

$$\text{INSERTION LOSS} = 20 \log \frac{V_{OUT} \text{ WITH SWITCH}}{V_{OUT} \text{ WITHOUT SWITCH}}$$

03275-029

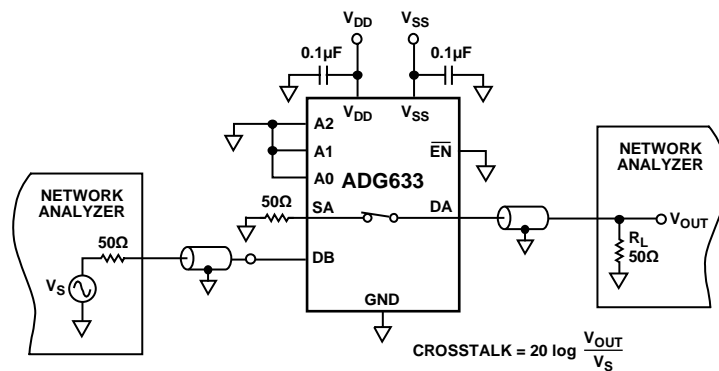
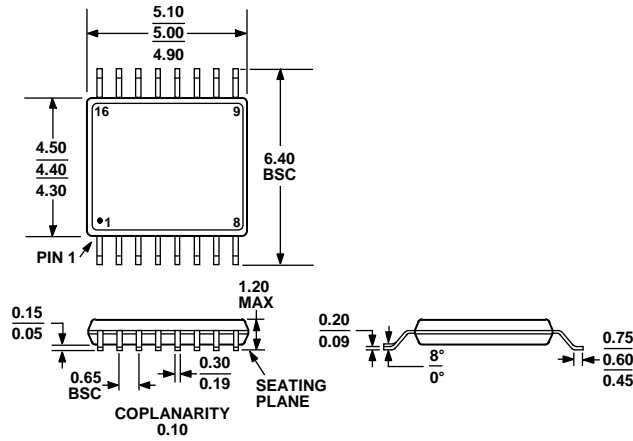

Figure 30. Channel-to-Channel Crosstalk

$$\text{CROSSTALK} = 20 \log \frac{V_{OUT}}{V_S}$$

03275-030

OUTLINE DIMENSIONS



COMPLIANT TO JEDEC STANDARDS MO-153-AB

Figure 31. 16-Lead Thin Shrink Small Outline Package [TSSOP] (RU-16)

Dimensions shown in millimeters

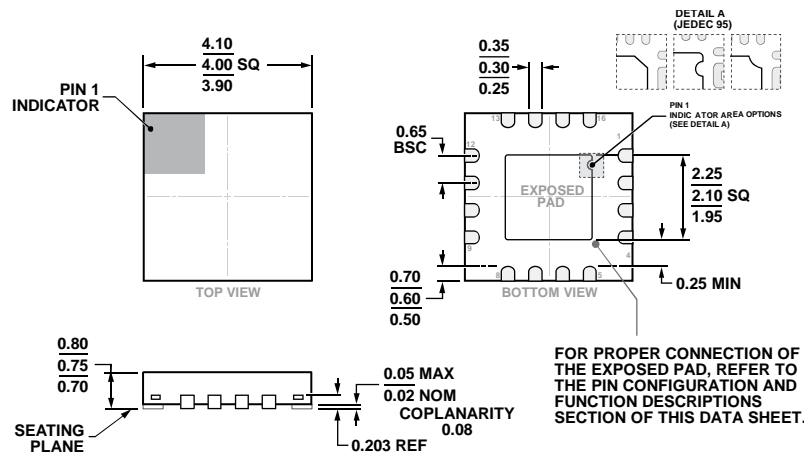

COMPLIANT TO JEDEC STANDARDS MO-220-WGGC.

Figure 32. 16-Lead Frame Chip Scale Package [LF CSP]

4 mm x 4 mm Body and 0.75 mm Package Height (CP-16-23)

Dimensions shown in millimeters

ORDERING GUIDE

| Model ¹ | Temperature Range | Package Description | Package Option |
|--------------------|-------------------|---|----------------|
| ADG633YRU | -40°C to +125°C | 16-Lead Thin Shrink Small Outline Package [TSSOP] | RU-16 |
| ADG633YRU-REEL7 | -40°C to +125°C | 16-Lead Thin Shrink Small Outline Package [TSSOP] | RU-16 |
| ADG633YRUZ | -40°C to +125°C | 16-Lead Thin Shrink Small Outline Package [TSSOP] | RU-16 |
| ADG633YRUZ-REEL7 | -40°C to +125°C | 16-Lead Thin Shrink Small Outline Package [TSSOP] | RU-16 |
| ADG633YCPZ | -40°C to +85°C | 16-Lead Lead Frame Chip Scale Package [LF CSP] | CP-16-23 |
| ADG633YCPZ-REEL7 | -40°C to +85°C | 16-Lead Lead Frame Chip Scale Package [LF CSP] | CP-16-23 |

¹ Z = RoHS Compliant Part.

NOTES

NOTES

Looking for pricing, stock, or lifecycle information?

Click below to explore more details on WIN SOURCE:

 [View ADG633YCP on WIN SOURCE](#)

 [Analog Devices Inc. Information](#)

Optimize Your Supply Chain with WIN SOURCE Solutions

-  Global Sourcing Solution
-  Obsolete Management
-  Cost Control Management
-  Shortage Management
-  Alternative Solution
-  Excess Inventory Management