



# THE DATASHEET OF MC100ELT25D





# MC10ELT25, MC100ELT25

## ATTRIBUTES

Characteristics	Value
Internal Input Pulldown Resistors	75 k $\Omega$
Internal Input Pullup Resistors	N/A
ESD Protection Human Body Model Machine Model	> 1 kV > 400 V
Moisture Sensitivity (Note 1)	Level 1
Flammability Rating Oxygen Index: 28 to 34	UL 94 V-0 @ 0.125 in
Transistor Count	38 Devices
Meets or Exceeds JEDEC Spec EIA/JESD78 IC Latchup Test	

1. Refer to Application Note AND8003/D for additional information.

## MAXIMUM RATINGS

Symbol	Parameter	Condition 1	Condition 2	Rating	Unit
V <sub>CC</sub>	Positive Power Supply	GND = 0 V	V <sub>EE</sub> = -5.0 V	7	V
V <sub>EE</sub>	Negative Power Supply	GND = 0 V	V <sub>CC</sub> = +5.0 V	-8	V
V <sub>IN</sub>	Input Voltage	GND = 0 V		0 to V <sub>EE</sub>	V
I <sub>BB</sub>	V <sub>BB</sub> Sink/Source			$\pm 0.5$	mA
T <sub>A</sub>	Operating Temperature Range			-40 to +85	$^{\circ}$ C
T <sub>stg</sub>	Storage Temperature Range			-65 to +150	$^{\circ}$ C
$\theta_{JA}$	Thermal Resistance (Junction-to-Ambient)	0 lfpm 500 lfpm	SOIC-8 SOIC-8	190 130	$^{\circ}$ C/W $^{\circ}$ C/W
$\theta_{JC}$	Thermal Resistance (Junction-to-Case)	Standard Board	SOIC-8	41 to 44	$^{\circ}$ C/W
$\theta_{JA}$	Thermal Resistance (Junction-to-Ambient)	0 lfpm 500 lfpm	TSSOP-8 TSSOP-8	185 140	$^{\circ}$ C/W $^{\circ}$ C/W
$\theta_{JC}$	Thermal Resistance (Junction-to-Case)	Standard Board	TSSOP-8	41 to 44 $\pm$ 5%	$^{\circ}$ C/W
T <sub>sol</sub>	Wave Solder	< 2 to 3 sec @ 248 $^{\circ}$ C		265	$^{\circ}$ C

Maximum ratings applied to the device are individual stress limit values (not normal operating conditions) and are not valid simultaneously. If stress limits are exceeded device functional operation is not implied, damage may occur and reliability may be affected. Functional operation should be restricted to the Recommended Operating Conditions.

# MC10ELT25, MC100ELT25

## 10ELT SERIES NECL INPUT DC CHARACTERISTICS $V_{CC} = 5.0\text{ V}$ ; $V_{EE} = -5.0\text{ V}$ ; $GND = 0\text{ V}$ (Note 2)

Symbol	Characteristic	-40°C			25°C			85°C			Unit
		Min	Typ	Max	Min	Typ	Max	Min	Typ	Max	
$V_{IH}$	Input HIGH Voltage (Single-Ended) (Note 3)	-1230		-890	-1130		-810	-1060		-720	mV
$V_{IL}$	Input LOW Voltage (Single-Ended) (Note 3)	-1950		-1500	-1950		-1480	-1950		-1445	mV
$V_{BB}$	Output Voltage Reference	-1.43		-1.30	-1.35		-1.25	-1.31		-1.19	V
$V_{IHCMR}$	Input HIGH Voltage Common Mode Range (Differential) (Notes 3 and 4)	-2.8		0.0	-2.8		0.0	-2.8		0.0	V
$I_{IH}$	Input HIGH Current			255			175			175	$\mu\text{A}$
$I_{IL}$	Input LOW Current	0.5			0.5			0.3			$\mu\text{A}$

NOTE: Device will meet the specifications after thermal equilibrium has been established when mounted in a test socket or printed circuit board with maintained transverse airflow greater than 500 lfm. Electrical parameters are guaranteed only over the declared operating temperature range. Functional operation of the device exceeding these conditions is not implied. Device specification limit values are applied individually under normal operating conditions and not valid simultaneously.

2. Input parameters vary 1:1 with GND.  $V_{EE}$  can vary +0.06 V / -0.5 V.

3. TTL output  $R_L = 500\ \Omega$  to GND

4.  $V_{IHCMR}$  min varies 1:1 with  $V_{EE}$ ,  $V_{IHCMR}$  max varies 1:1 with GND.

## 100ELT SERIES NECL INPUT DC CHARACTERISTICS $V_{CC} = 5.0\text{ V}$ ; $V_{EE} = -5.0\text{ V}$ ; $GND = 0\text{ V}$ (Note 5)

Symbol	Characteristic	-40°C			25°C			85°C			Unit
		Min	Typ	Max	Min	Typ	Max	Min	Typ	Max	
$V_{IH}$	Input HIGH Voltage (Single-Ended) (Note 6)	-1165		-880	-1165		-880	-1165		-880	mV
$V_{IL}$	Input LOW Voltage (Single-Ended) (Note 6)	-1810		-1475	-1810		-1475	-1810		-1475	mV
$V_{BB}$	Output Voltage Reference	-1.38		-1.26	-1.38		-1.26	-1.38		-1.26	V
$V_{IHCMR}$	Input HIGH Voltage Common Mode Range (Differential) (Notes 6 and 7)	-2.8		0.0	-2.8		0.0	-2.8		0.0	V
$I_{IH}$	Input HIGH Current			255			175			175	$\mu\text{A}$
$I_{IL}$	Input LOW Current	0.5			0.5			0.5			$\mu\text{A}$

NOTE: Device will meet the specifications after thermal equilibrium has been established when mounted in a test socket or printed circuit board with maintained transverse airflow greater than 500 lfm. Electrical parameters are guaranteed only over the declared operating temperature range. Functional operation of the device exceeding these conditions is not implied. Device specification limit values are applied individually under normal operating conditions and not valid simultaneously.

5. Input parameters vary 1:1 with GND.  $V_{EE}$  can vary +0.8 V / -0.5 V.

6. TTL output  $R_L = 500\ \Omega$  to GND

7.  $V_{IHCMR}$  min varies 1:1 with  $V_{EE}$ ,  $V_{IHCMR}$  max varies 1:1 with GND.

## TTL OUTPUT DC CHARACTERISTICS $V_{CC} = 4.5\text{ V}$ to $5.5\text{ V}$ ; $T_A = -40^\circ\text{C}$ to $+85^\circ\text{C}$

Symbol	Characteristic	Condition	Min	Typ	Max	Unit
$V_{OH}$	Output HIGH Voltage	$I_{OH} = -3.0\text{ mA}$	2.4			V
$V_{OL}$	Output LOW Voltage	$I_{OL} = 24\text{ mA}$			0.5	V
$I_{CCH}$	Power Supply Current			11	16	mA
$I_{CCL}$	Power Supply Current			13	18	mA
$I_{EE}$	Negative Power Supply Current			15	21	mA
$I_{OS}$	Output Short Circuit Current		-150		-60	mA

NOTE: Device will meet the specifications after thermal equilibrium has been established when mounted in a test socket or printed circuit board with maintained transverse airflow greater than 500 lfm. Electrical parameters are guaranteed only over the declared operating temperature range. Functional operation of the device exceeding these conditions is not implied. Device specification limit values are applied individually under normal operating conditions and not valid simultaneously.

# MC10ELT25, MC100ELT25

## AC CHARACTERISTICS $V_{CC}= 5.0\text{ V}$ ; $V_{EE}= -5.0\text{ V}$ ; $GND= 0\text{ V}$ (Note 8 and Note 9)

Symbol	Characteristic	-40°C			25°C			85°C			Unit
		Min	Typ	Max	Min	Typ	Max	Min	Typ	Max	
$f_{max}$	Maximum Toggle Frequency					100					MHz
$t_{PLH}$	Propagation Delay @ 1.5 V	1.7		3.6	1.7		3.6	1.7		3.6	ns
$t_{PHL}$	Propagation Delay @ 1.5 V	2.6		4.1	2.6		4.1	2.6		4.1	ns
$t_{JITTER}$	Random Clock Jitter (RMS)					35					ps
$t_r$ $t_f$	Output Rise/Fall Times QTTL 10% – 90%					1.9 2.3					ns
$V_{PP}$	Input Swing (Note 10)	200		1000	200		1000	200		1000	mV

NOTE: Device will meet the specifications after thermal equilibrium has been established when mounted in a test socket or printed circuit board with maintained transverse airflow greater than 500 lpm. Electrical parameters are guaranteed only over the declared operating temperature range. Functional operation of the device exceeding these conditions is not implied. Device specification limit values are applied individually under normal operating conditions and not valid simultaneously.

8.  $V_{CC}$  can vary  $\pm 0.25\text{ V}$ .

$V_{EE}$  can vary  $+0.06\text{ V} / -0.5\text{ V}$  for 10ELT;  $V_{EE}$  can vary  $+0.8\text{ V} / -0.5\text{ V}$  for 100ELT.

9.  $R_L = 500\ \Omega$  to GND and  $C_L = 20\text{ pF}$  to GND. Refer to Figure 2.

10.  $V_{PP}(\text{min})$  is the minimum input swing for which AC parameters are guaranteed. The device has a DC gain of  $\approx 40$ .

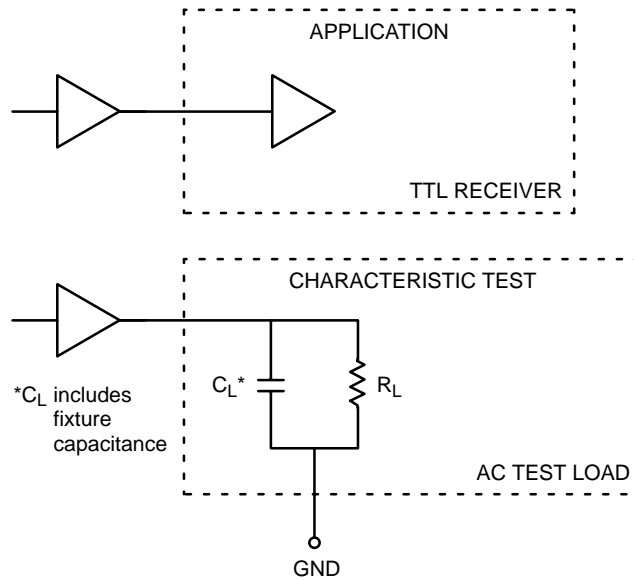

Figure 2. TTL Output Loading Used for Device Evaluation

## MC10ELT25, MC100ELT25

### Resource Reference of Application Notes

- AN1404** – ECLinPS Circuit Performance at Non-Standard  $V_{IH}$  Levels
- AN1405** – ECL Clock Distribution Techniques
- AN1406** – Designing with PECL (ECL at +5.0 V)
- AN1503** – ECLinPS I/O SPICE Modeling Kit
- AN1504** – Metastability and the ECLinPS Family
- AN1560** – Low Voltage ECLinPS SPICE Modeling Kit
- AN1568** – Interfacing Between LVDS and ECL
- AN1596** – ECLinPS Lite Translator ELT Family SPICE I/O Model Kit
- AN1650** – Using Wire-OR Ties in ECLinPS Designs
- AN1672** – The ECL Translator Guide
- AND8001** – Odd Number Counters Design
- AND8002** – Marking and Date Codes
- AND8020** – Termination of ECL Logic Devices
- AND8090** – AC Characteristics of ECL Devices

# MC10ELT25, MC100ELT25

## PACKAGE DIMENSIONS

### SOIC-8 D SUFFIX PLASTIC SOIC PACKAGE CASE 751-07 ISSUE AB

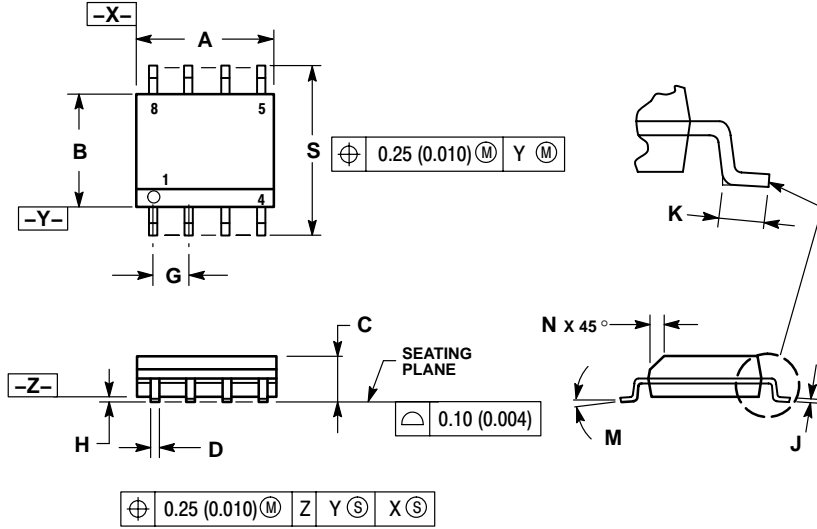

#### NOTES:

1. DIMENSIONING AND TOLERANCING PER ANSI Y14.5M, 1982.
2. CONTROLLING DIMENSION: MILLIMETER.
3. DIMENSION A AND B DO NOT INCLUDE MOLD PROTRUSION.
4. MAXIMUM MOLD PROTRUSION 0.15 (0.006) PER SIDE.
5. DIMENSION D DOES NOT INCLUDE DAMBAR PROTRUSION. ALLOWABLE DAMBAR PROTRUSION SHALL BE 0.127 (0.005) TOTAL IN EXCESS OF THE D DIMENSION AT MAXIMUM MATERIAL CONDITION.
6. 751-01 THRU 751-06 ARE OBSOLETE. NEW STANDARD IS 751-07.

DIM	MILLIMETERS		INCHES	
	MIN	MAX	MIN	MAX
A	4.80	5.00	0.189	0.197
B	3.80	4.00	0.150	0.157
C	1.35	1.75	0.053	0.069
D	0.33	0.51	0.013	0.020
G	1.27 BSC		0.050 BSC	
H	0.10	0.25	0.004	0.010
J	0.19	0.25	0.007	0.010
K	0.40	1.27	0.016	0.050
M	0°	8°	0°	8°
N	0.25	0.50	0.010	0.020
S	5.80	6.20	0.228	0.244

### SOLDERING FOOTPRINT

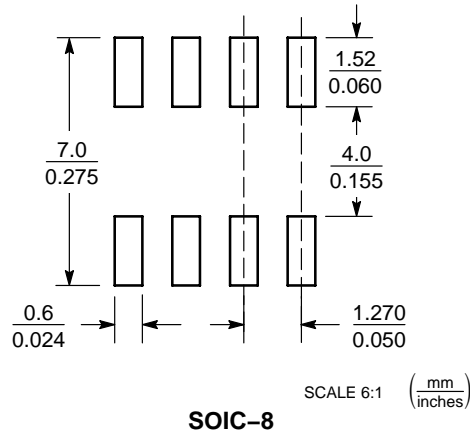

### SOIC-8

# MC10ELT25, MC100ELT25

## PACKAGE DIMENSIONS

TSSOP-8  
DT SUFFIX  
PLASTIC TSSOP PACKAGE  
CASE 948R-02  
ISSUE A

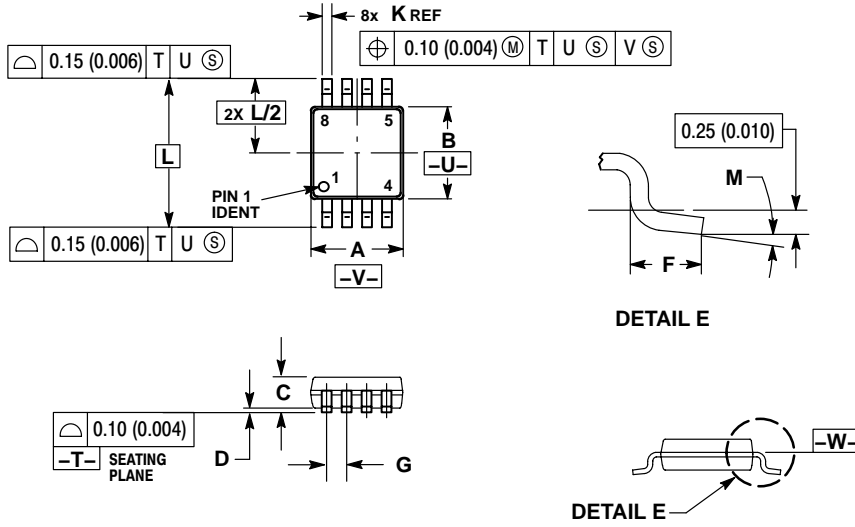

**NOTES:**

1. DIMENSIONING AND TOLERANCING PER ANSI Y14.5M, 1982.
2. CONTROLLING DIMENSION: MILLIMETER.
3. DIMENSION A DOES NOT INCLUDE MOLD FLASH, PROTRUSIONS OR GATE BURRS. MOLD FLASH OR GATE BURRS SHALL NOT EXCEED 0.15 (0.006) PER SIDE.
4. DIMENSION B DOES NOT INCLUDE INTERLEAD FLASH OR PROTRUSION. INTERLEAD FLASH OR PROTRUSION SHALL NOT EXCEED 0.25 (0.010) PER SIDE.
5. TERMINAL NUMBERS ARE SHOWN FOR REFERENCE ONLY.
6. DIMENSION A AND B ARE TO BE DETERMINED AT DATUM PLANE -W-.

DIM	MILLIMETERS		INCHES	
	MIN	MAX	MIN	MAX
A	2.90	3.10	0.114	0.122
B	2.90	3.10	0.114	0.122
C	0.80	1.10	0.031	0.043
D	0.05	0.15	0.002	0.006
F	0.40	0.70	0.016	0.028
G	0.65 BSC		0.026 BSC	
K	0.25	0.40	0.010	0.016
L	4.90 BSC		0.193 BSC	
M	0°	6°	0°	6°

# MC10ELT25, MC100ELT25

**ON Semiconductor** and  are registered trademarks of Semiconductor Components Industries, LLC (SCILLC). SCILLC reserves the right to make changes without further notice to any products herein. SCILLC makes no warranty, representation or guarantee regarding the suitability of its products for any particular purpose, nor does SCILLC assume any liability arising out of the application or use of any product or circuit, and specifically disclaims any and all liability, including without limitation special, consequential or incidental damages. "Typical" parameters which may be provided in SCILLC data sheets and/or specifications can and do vary in different applications and actual performance may vary over time. All operating parameters, including "Typicals" must be validated for each customer application by customer's technical experts. SCILLC does not convey any license under its patent rights nor the rights of others. SCILLC products are not designed, intended, or authorized for use as components in systems intended for surgical implant into the body, or other applications intended to support or sustain life, or for any other application in which the failure of the SCILLC product could create a situation where personal injury or death may occur. Should Buyer purchase or use SCILLC products for any such unintended or unauthorized application, Buyer shall indemnify and hold SCILLC and its officers, employees, subsidiaries, affiliates, and distributors harmless against all claims, costs, damages, and expenses, and reasonable attorney fees arising out of, directly or indirectly, any claim of personal injury or death associated with such unintended or unauthorized use, even if such claim alleges that SCILLC was negligent regarding the design or manufacture of the part. SCILLC is an Equal Opportunity/Affirmative Action Employer. This literature is subject to all applicable copyright laws and is not for resale in any manner.

## PUBLICATION ORDERING INFORMATION

### LITERATURE FULFILLMENT:

Literature Distribution Center for ON Semiconductor  
P.O. Box 5163, Denver, Colorado 80217 USA

**Phone:** 303-675-2175 or 800-344-3860 Toll Free USA/Canada

**Fax:** 303-675-2176 or 800-344-3867 Toll Free USA/Canada

**Email:** [orderlit@onsemi.com](mailto:orderlit@onsemi.com)

**N. American Technical Support:** 800-282-9855 Toll Free  
USA/Canada

**Japan:** ON Semiconductor, Japan Customer Focus Center  
2-9-1 Kamimeguro, Meguro-ku, Tokyo, Japan 153-0051  
**Phone:** 81-3-5773-3850



**ON Semiconductor Website:** <http://onsemi.com>

**Order Literature:** <http://www.onsemi.com/litorder>

For additional information, please contact your  
local Sales Representative.

## Looking for pricing, stock, or lifecycle information?

Click below to explore more details on WIN SOURCE:

-  [View MC100ELT25D](#) on WIN SOURCE
-  [ON Semiconductor](#) Information

## Optimize Your Supply Chain with WIN SOURCE Solutions

-  Global Sourcing Solution
-  Obsolete Management
-  Cost Control Management
-  Shortage Management
-  Alternative Solution
-  Excess Inventory Management