



**THE DATASHEET OF
NB4L339MNR4G**



NB4L339

2.5 V / 3.3 V Differential 2:1 Clock IN to Differential LVPECL Clock Generator / Divider / Fan-Out Buffer

Multi-Level Inputs w/ Internal Termination

Description

The NB4L339 is a multi-function Clock generator featuring a 2:1 Clock multiplexer front end and simultaneously outputs a selection of four different divide ratios from its four divider blocks; $\div 1/\div 2/\div 4/\div 8$. One divide block has a choice of $\div 1$ or $\div 2$.

The output of each divider block is fanned-out to two identical differential LVPECL copies of the selected clock. All outputs provide standard LVPECL voltage levels when externally terminated with a 50-ohm resistor to $V_{CC} - 2$ V.

The differential Clock inputs incorporate internal 50- Ω termination resistors and will accept LVPECL, CML or LVDS logic levels.

The common Output Enable pin (EN) is synchronous so that the internal dividers will only be enabled/disabled when the internal clock is in the LOW state. This avoids any chance of generating a runt clock pulse on the internal clock when the device is enabled/disabled as can happen with an asynchronous control. An internal runt pulse could lead to losing synchronization between the internal divider stages. The internal enable flip-flop is clocked on the falling edge of the input clock. Therefore, all associated specification limits are referenced to the negative edge of the clock input.

This device is housed in a 5x5 mm 32 pin QFN package.

Features

- Maximum Input/Output Clock Frequency > 700 MHz
- Low Skew LVPECL Outputs, 15 ps typical
- 1 ns Typical Propagation Delay
- 150 ps Typical Rise and Fall Times
- 0.15 ps Typical RMS Phase Jitter
- 0.5 ps Typical RMS Random Clock Period Jitter
- LVPECL, CML or LVDS Input Compatible
- Operating Range: $V_{CC} = 2.375$ V to 3.6 V with $V_{EE} = 0$ V
- LVPECL Output Level; 750 mV Peak-to-Peak, Typical
- Internal 50- Ω Input Termination Provided
- Synchronous Output Enable/Disable
- Asynchronous Master Reset
- Functionally Compatible with Existing 2.5 V / 3.3 V LVEL, LVEP, EP, and SG Devices
- -40°C to 85°C Ambient Operating Temperature
- 32-Pin QFN, 5 mm x 5 mm
- This is a Pb-Free Device



ON Semiconductor®

<http://onsemi.com>

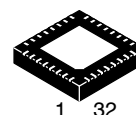

QFN32
MN SUFFIX
CASE 488AM

MARKING DIAGRAM

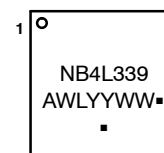

A = Assembly Location
WL = Wafer Lot
YY = Year
WW = Work Week
▪ = Pb-Free Package

(Note: Microdot may be in either location)

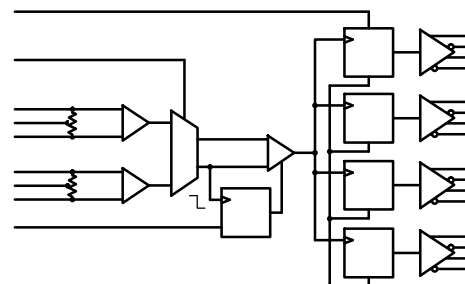

Figure 1. Simplified Block Diagram

ORDERING INFORMATION

See detailed ordering and shipping information on page 11 of this data sheet.

NB4L339

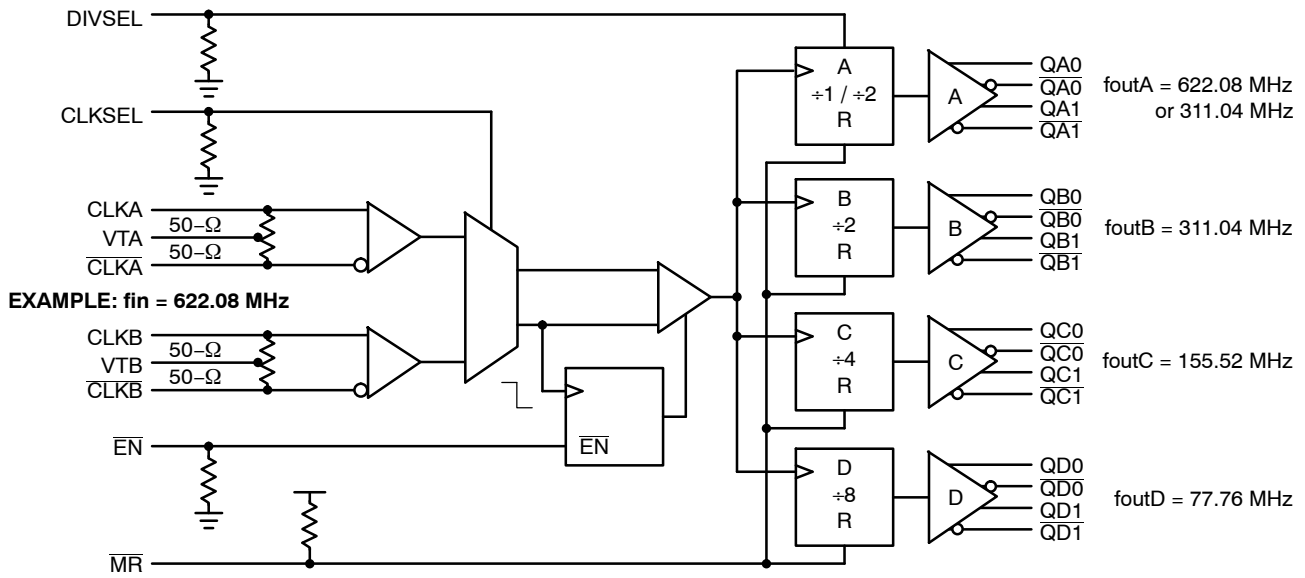

Figure 2. Detailed Logic Diagram

Table 1. Input Select Function Table

CLKSEL*	CLK Input Selected
0	CLKA
1	CLKB

Table 2. Divider Select Function Table

DIVSEL*	QA Divide
0	Divide by 1
1	Divide by 2

Table 3. Clock Enable/Disable Function Table

CLK Input	EN*	MR**	Function
Low to High Transition	0	H	Divide – Outputs Active
High to Low Transition	1	H	Hold Q – Outputs Inactive
X (Don't Care)	X (Don't Care)	L	Reset Q

* Pin will default LOW when left OPEN.

** Pin will default HIGH when left OPEN.

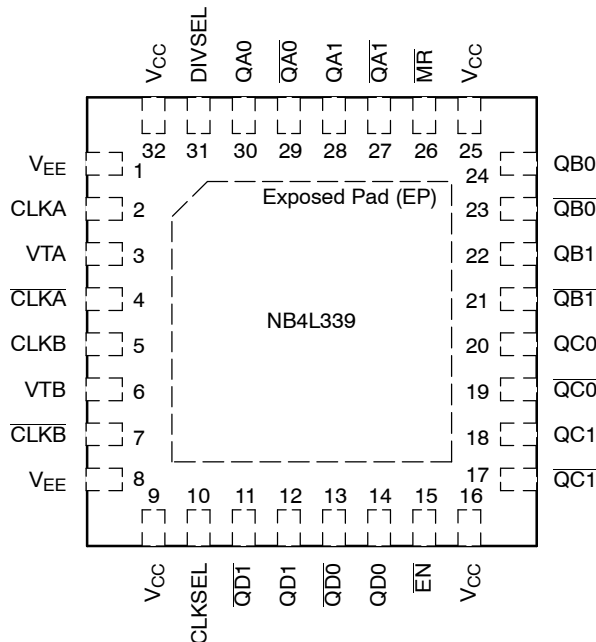

Figure 3. Pinout QFN-32 (Top View)

Table 4. Pin Description

Pin	Name	I/O	Description
1, 8, EP	V _{EE}	–	Negative Supply Voltage
2	CLKA	LVPECL, CML, LVDS Input	Non-inverted differential input (A). (Note 1)
3	VTA	–	Internal 100-Ω center-tapped termination pin for CLKA and $\overline{\text{CLKA}}$ (Note 1).
4	$\overline{\text{CLKA}}$	LVPECL, CML, LVDS Input	Inverted differential input (A). (Note 1)
5	CLKB	LVPECL, CML, LVDS Input	Non-inverted differential input (B). (Note 1)
6	VTB	–	Internal 100-Ω center-tapped termination pin for CLKB and $\overline{\text{CLKB}}$. (Note 1)
7	$\overline{\text{CLKB}}$	LVPECL, CML, LVDS Input	Inverted differential input (B). (Note 1)
9, 16, 25, 32	V _{CC}	–	Positive Supply Voltage
10	CLKSEL	LVC MOS/LVTTL	Asynchronous Clock input select pin. This pin defaults LOW when left open with 80 kΩ resistor to V _{EE} .
11	$\overline{\text{QD1}}$	LVPECL Output	Inverted differential (D1) output. Typically terminated with 50 Ω resistor to V _{CC} – 2 V
12	QD1	LVPECL Output	Non-inverted Differential (D1) Output. Typically terminated with 50 Ω resistor to V _{CC} – 2 V.
13	$\overline{\text{QD0}}$	LVPECL Output	Inverted differential (D0) output. Typically terminated with 50 Ω resistor to V _{CC} – 2 V.
14	QD0	LVPECL Output	Non-inverted Differential (D0) Output. Typically terminated with 50 Ω resistor to V _{CC} – 2 V.
15	$\overline{\text{EN}}$	LVC MOS/LVTTL	Synchronous Output Enable/Disable pin. This pin defaults LOW when left open with 80 kΩ resistor to V _{EE} .
17	$\overline{\text{QC1}}$	LVPECL Output	Inverted differential (C1) output. Typically terminated with 50 Ω resistor to V _{CC} – 2 V.
18	QC1	LVPECL Output	Non-inverted Differential (C1) Output. Typically terminated with 50 Ω resistor to V _{CC} – 2 V.
19	$\overline{\text{QC0}}$	LVPECL Output	Inverted differential (C0) output. Typically terminated with 50 Ω resistor to V _{CC} – 2 V.
20	QC0	LVPECL Output	Non-inverted Differential (C0) Output. Typically terminated with 50 Ω resistor to V _{CC} – 2 V.
21	$\overline{\text{QB1}}$	LVPECL Output	Inverted differential (B1) output. Typically terminated with 50 Ω resistor to V _{CC} – 2 V.
22	QB1	LVPECL Output	Non-inverted Differential (B1) Output. Typically terminated with 50 Ω resistor to V _{CC} – 2 V.
23	$\overline{\text{QB0}}$	LVPECL Output	Inverted differential (B0) output. Typically terminated with 50 Ω resistor to V _{CC} – 2 V.
24	QB0	LVPECL Output	Non-inverted Differential (B0) Output. Typically terminated with 50 Ω resistor to V _{CC} – 2 V.
26	MR	LVC MOS/LVTTL	Master Reset Asynchronous. This pin defaults HIGH when left open with 80 kΩ resistor to V _{CC} .
27	$\overline{\text{QA1}}$	LVPECL Output	Inverted differential (A1) output. Typically terminated with 50 Ω resistor to V _{CC} – 2 V.
28	QA1	LVPECL Output	Non-inverted Differential (A1) Output. Typically terminated with 50 Ω resistor to V _{CC} – 2 V.
29	$\overline{\text{QA0}}$	LVPECL Output	Inverted differential (A0) output. Typically terminated with 50 Ω resistor to V _{CC} – 2 V.
30	QA0	LVPECL Output	Non-inverted Differential (A0) Output. Typically terminated with 50 Ω resistor to V _{CC} – 2 V.
31	DIVSEL	LVC MOS/LVTTL	Asynchronous Divide Select Pin selects A divide block outputs to divide by 1 or divide by 2. Defaults LOW when left open, divide-by-1, with 80 kΩ resistor to V _{EE} .
–	EP	–	Exposed Pad. The exposed pad (EP) on package bottom (see case drawing) is thermally connected to the die for improved heat transfer out of package and must be attached to a heat-sinking conduit. The pad is electrically connected to V _{EE} and must be connected to V _{EE} on the PC board.

1. In the differential configuration when the input termination pin (VTx / $\overline{\text{VTx}}$) are connected to a common termination voltage or left open, and if no signal is applied on CLKx / $\overline{\text{CLKx}}$ input then the device will be susceptible to self-oscillation.

NB4L339

Table 5. ATTRIBUTES

Characteristics		Value
Input Default State Resistors		80 kΩ
ESD Protection	Human Body Model Machine Model	> 2.0 kV > 100 V
Moisture Sensitivity (Note 2)	QFN-32	Level 1
Flammability Rating	Oxygen Index: 28 to 34	UL 94 V-0 @ 0.125 in
Transistor Count		366
Meets or exceeds JEDEC Spec EIA/JESD78 IC Latchup Test		

2. For additional information, see Application Note AND8003/D.

Table 6. MAXIMUM RATINGS

Symbol	Parameter	Condition 1	Condition 2	Rating	Units
V _{CC}	Positive Power Supply	V _{EE} = 0 V		4.0	V
V _{IO}	Input/Output Voltage	V _{EE} = 0 V	-0.5 = V _{io} ≤ V _{CC} + 0.5	4.0	V
V _{INPP}	Differential Input Voltage Swing CLK - $\overline{\text{CLK}}$			2.8	V
I _{IN}	Input Current Through R _T (50 Ω Resistor)	Static Surge		45 80	mA
I _{OUT}	Output Current	Continuous Surge		50 100	mA
T _A	Operating Temperature Range	QFN-32		-40 to +85	°C
T _{stg}	Storage Temperature Range			-65 to +150	°C
θ _{JA}	Thermal Resistance (Junction-to-Ambient) (Note 3)	0 LFPM 500 LFPM	QFN-32 QFN-32	31 27	°C/W
θ _{JC}	Thermal Resistance (Junction-to-Case)	(Note 3)	QFN-32	12	°C/W
T _{sol}	Wave Solder (Pb-Free)			265	°C

Stresses exceeding Maximum Ratings may damage the device. Maximum Ratings are stress ratings only. Functional operation above the Recommended Operating Conditions is not implied. Extended exposure to stresses above the Recommended Operating Conditions may affect device reliability.

3. JEDEC standard multilayer board – 2S2P (2 signal, 2 power) with 8 filled thermal vias under exposed pad.

NB4L339

Table 7. DC CHARACTERISTICS, CLOCK Inputs, LVPECL Outputs

$V_{CC} = 2.375\text{ V to }3.6\text{ V}$, $V_{EE} = 0\text{ V}$, $T_A = -40^\circ\text{C to }+85^\circ\text{C}$ (Note 5)

Symbol	Characteristic	Min	Typ	Max	Unit
I_{EE}	Power Supply Current (Inputs and Outputs Open)	58	70	90	mA

LVPECL Outputs (Note 4)

V_{OH}	Output HIGH Voltage	$V_{CC} - 1135$ 2155 $V_{CC} = 2.5\text{ V}$ 1355	$V_{CC} - 1020$ 2280 1480	$V_{CC} - 760$ 2540 1740	mV
V_{OL}	Output LOW Voltage	$V_{CC} - 1935$ 1355 $V_{CC} = 2.5\text{ V}$ 555	$V_{CC} - 1770$ 1530 730	$V_{CC} - 1560$ 1740 940	mV

Differential Input Driven Single-Ended (see Figures 6 & 8)

V_{th}	Input Threshold Reference Voltage Range (Note 6)	1125		$V_{CC} - 75$	mV
V_{IH}	Single-ended Input HIGH Voltage	$V_{th} + 75$		V_{CC}	mV
V_{IL}	Single-ended Input LOW Voltage	V_{EE}		$V_{th} - 75$	mV
V_{ISE}	Single-ended Input Voltage ($V_{IH} - V_{IL}$)	150		2800	mV

Differential Inputs Driven Differentially (see Figures 7 & 9)

V_{IHD}	Differential Input HIGH Voltage	1200		V_{CC}	mV
V_{ILD}	Differential Input LOW Voltage	V_{EE}		$V_{CC} - 150$	mV
V_{CMR}	Input Common Mode Range (Differential Configuration) (Note 8)	1125		$V_{CC} - 75$	mV
V_{ID}	Differential Input Voltage Swing ($V_{IHD} - V_{ILD}$)	150		2800	mV
I_{IH}	Input HIGH Current CLKx / $\overline{\text{CLKx}}$ (VTx Open)	10		40	μA
I_{IL}	Input LOW Current CLKx / $\overline{\text{CLKx}}$ (VTx Open)	-10		10	μA

Single-Ended LVCMOS / LVTTTL Control Inputs

V_{IH}	Single-ended Input HIGH Voltage	2000		V_{CC}	mV
V_{IL}	Single-ended Input LOW Voltage	V_{EE}		800	mV
I_{IH}	Input HIGH Current CLKSEL, DIVSEL, $\overline{\text{EN}}$, $\overline{\text{MR}}$	40 -10		115 10	μA
I_{IL}	Input LOW Current CLKSEL, DIVSEL, $\overline{\text{EN}}$, $\overline{\text{MR}}$	-10 -115		10 -40	μA

Termination Resistors

R_{TIN}	Internal Input Termination Resistor (Measured across CLKx and $\overline{\text{CLKx}}$)	80	100	120	Ω
R_{TIN}	Internal Input Termination Resistor (Measured from CLKx to VTx)	40	50	60	Ω

NOTE: Device will meet the specifications after thermal equilibrium has been established when mounted in a test socket or printed circuit board with maintained transverse airflow greater than 500 lpm. Electrical parameters are guaranteed only over the declared operating temperature range. Functional operation of the device exceeding these conditions is not implied. Device specification limit values are applied individually under normal operating conditions and not valid simultaneously.

- LVPECL outputs require 50 Ω receiver termination resistors to $V_{CC} - 2\text{ V}$ for proper operation.
- Input and output parameters vary 1:1 with V_{CC} .
- V_{th} is applied to the complementary input when operating in single-ended mode.
- V_{IHD} , V_{ILD} , V_{ID} and V_{CMR} parameters must be complied with simultaneously.
- V_{CMR} min varies 1:1 with V_{EE} , V_{CMR} max varies 1:1 with V_{CC} . The V_{CMR} range is referenced to the most positive side of the differential input signal.

NB4L339

Table 8. AC CHARACTERISTICS $V_{CC} = 2.375\text{ V to }3.6\text{ V}$, $V_{EE} = 0\text{ V}$ (Note 9)

Symbol	Characteristic	-40°C			25°C			85°C			Unit
		Min	Typ	Max	Min	Typ	Max	Min	Typ	Max	
$f_{in_{max}}$	Maximum Input CLOCK Frequency	700			700			700			MHz
V_{OUTPP}	Output Voltage Amplitude (@ $V_{INPPmin}$) (See Figure 4) $f_{in} \leq 622\text{ MHz}$	530	730		530	730		530	730		mV
t_{PLH} , t_{PHL}	Propagation Delay to Output Differential $\div 1$ CLKx/ \overline{CLKx} to Qx/ \overline{Qx} MR to Qx CLKSEL to Qx	0.8 1.2 0.8	1.0 – 1.0	1.3 5.0 1.3	0.8 1.2 0.8	1.0 – 1.0	1.3 5.0 1.3	0.8 1.2 0.8	1.0 – 1.0	1.3 5.0 1.3	ns
t_{rr}	Reset Recovery	4.0			4.0			4.0			ns
DCO	Output CLOCK Duty Cycle All Divides	40		60	40		60	40		60	%
t_{SKEW}	Within Device Skew (Note 11) Device to Device Skew (Note 12)		30 90	60 190		30 90	60 190		30 90	60 190	ps
t_s	Setup Time @ 50 MHz \overline{EN} to CLKx DIVSEL to CLKx	900 –100			900 –100			900 –100			ps
t_h	Hold Time @ 50 MHz CLKx to \overline{EN} CLKx to DIVSEL	800 0			800 0			800 0			ps
t_{PW}	Minimum Pulse Width MR	5.0			5.0			5.0			ns
Φ_N	Phase Noise $f_{in} = 622.08\text{ MHz}$ Outputs (A) Div by 1 10 kHz 100 kHz 1 MHz 10 MHz 20 MHz 40 MHz										dBc
t_{JIT1}	Integrated Phase Jitter (Figure 4) $f_{in} = 622.08\text{ MHz}$, 12 kHz – 20 MHz Offset All Divides		0.15	0.25		0.15	0.25		0.15	0.25	ps RMS
t_{JIT2}	Random Clock Period Jitter (Note 13) $f_{in} = 622.08\text{ MHz}$ All Divides		0.5	1.5		0.5	1.5		0.5	1.5	ps RMS
V_{INPP}	Input Voltage Swing/Sensitivity (Differential Configuration) (Note 14)	150			150			150			mV
t_r , t_f	Output Rise/Fall Times @ 622.08 MHz input frequency (20% – 80%)		150	250		150	250		150	250	ps

NOTE: Device will meet the specifications after thermal equilibrium has been established when mounted in a test socket or printed circuit board with maintained transverse airflow greater than 500 lfm. Electrical parameters are guaranteed only over the declared operating temperature range. Functional operation of the device exceeding these conditions is not implied. Device specification limit values are applied individually under normal operating conditions and not valid simultaneously.

9. Measured by forcing V_{INPP} (Min) from a 50% duty cycle clock source. All loading with an external $R_L = 50\ \Omega$ to $V_{CC} - 2\text{ V}$ Input edge rates 100 ps (20% – 80%).

10. Duty cycle skew is measured between differential outputs using the deviations of the sum of T_{pw-} and T_{pw+} @ 50 MHz.

11. Skew is measured between outputs under identical transitions and conditions. Duty cycle skew is defined only for differential operation when the delays are measured from the cross-point of the inputs to the cross-point of the outputs.

12. Device to device skew is measured between outputs under identical transition @ 50 MHz.

13. Additive RMS jitter with 50% duty cycle clock signal; all inputs and outputs active.

14. V_{INPP} (Max) cannot exceed $V_{CC} - V_{EE}$. Input voltage swing is a single-ended measurement operating in differential mode.

NB4L339

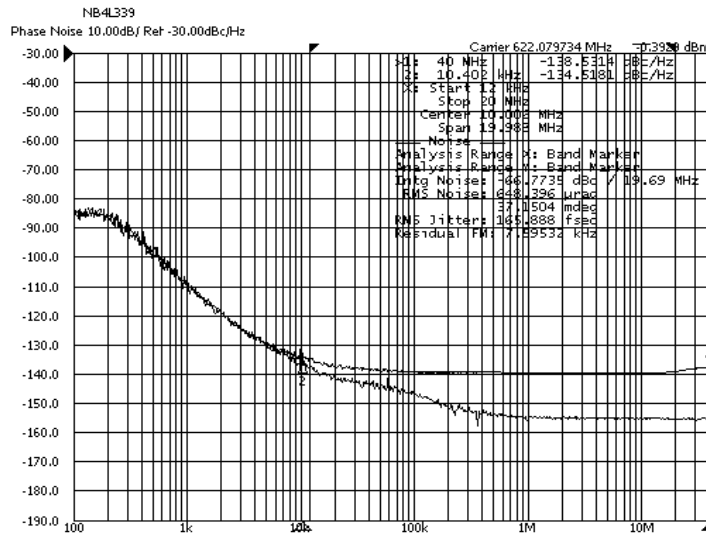

Figure 4. NB4L339 vs. Agilent 8665A 622.08 MHz at 3.3 V, Room Ambient

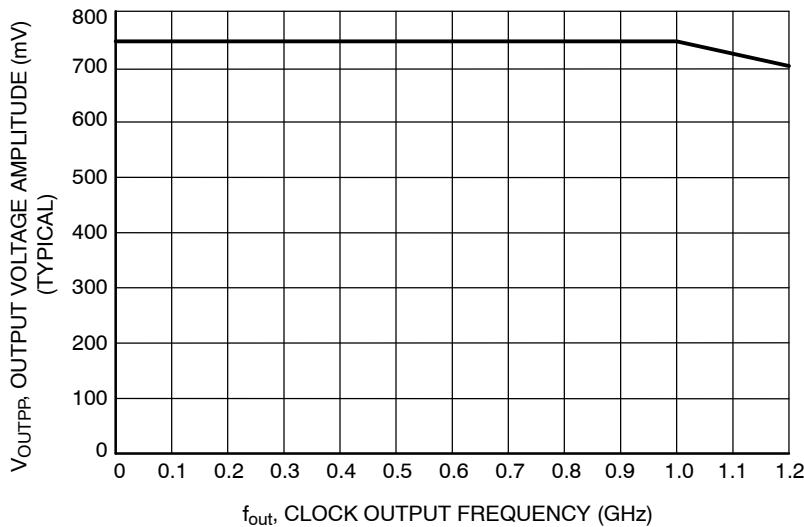

Figure 5. Output Voltage Amplitude (V_{OUTPP}) vs. Input Clock Frequency (f_{in}) at Ambient Temperature (Typical)

Application Information

The NB4L339 is a high-speed, Clock multiplexer, divider and low skew fan-out buffer featuring a 2:1 Clock multiplexer front end and outputs a selection of four different divide ratios; $\div 1/2/4/8$. One divide block has a choice of $\div 1$ or $\div 2$. The outputs of all four divider blocks are fanned-out to two pair of identical differential LVPECL copies of the selected clock. All outputs provide standard LVPECL voltage levels when externally terminated with a 50-ohm resistor to $V_{TT} = V_{CC} - 2$ V.

The differential Clock input buffers incorporate internal 50- Ω termination resistors in a 100- Ω center-tapped configuration and are accessible via a VTx pin. This feature provides transmission line termination on-chip, at the receiver end, eliminating external components. Inputs CLKA/B and $\overline{CLKA/B}$ must be signal driven or auto oscillation may result.

The NB4L339 Clock inputs can be driven by a variety of differential signal level technologies including LVDS, LVPECL, or CML.

The internal dividers are synchronous to each other. Therefore, the common output edges are precisely aligned.

The Output Enable pin (\overline{EN}) is synchronous so that the internal divider flip-flops will only be enabled/disabled when the internal clock is in the LOW state. This avoids any chance of generating a runt pulse on the internal clock when the device is enabled/disabled, as can happen with an asynchronous control. The internal enable flip-flop is clocked on the falling edge of the input clock. Therefore, all associated specification limits are referenced to the negative edge of the clock input.

The Master Reset (\overline{MR}) is asynchronous. When \overline{MR} is forced LOW, all Q outputs go to logic LOW.

NB4L339

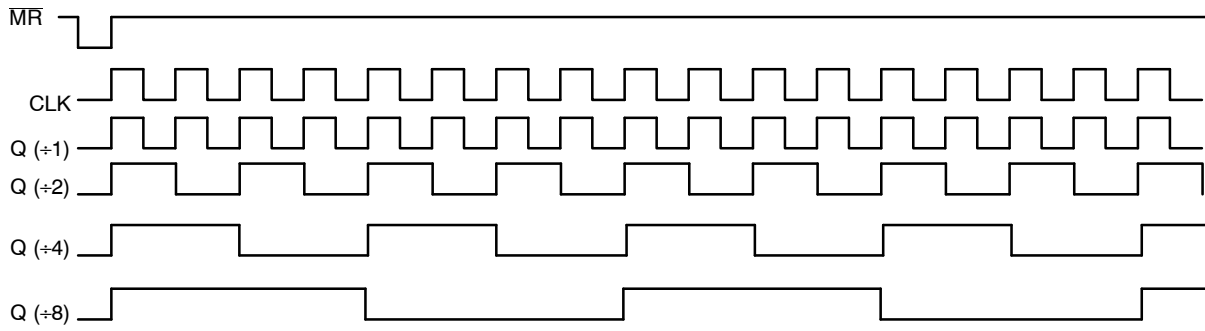
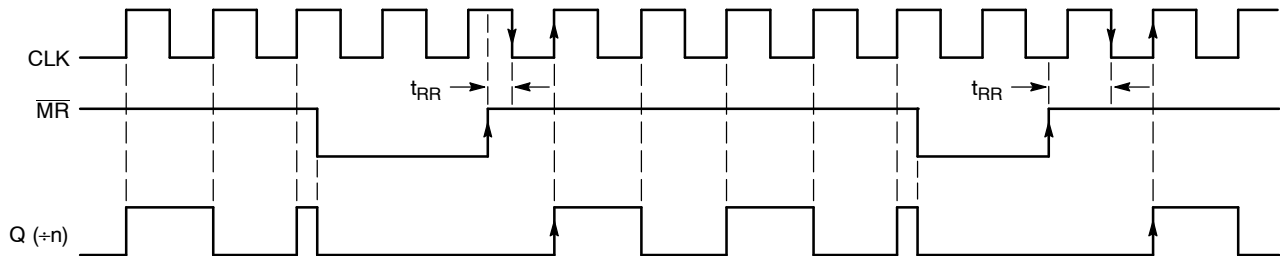

Figure 6. Timing Diagram



NOTE: On the rising edge of \overline{MR} , Q goes HIGH after the first rising edge of CLK, following a high-to-low clock transition.

Figure 7. Master Reset Timing Diagram

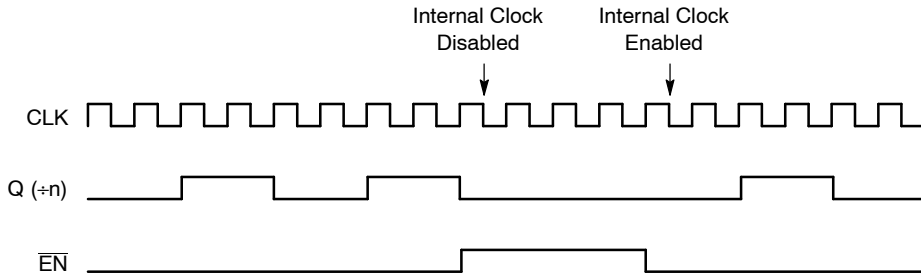

Figure 8. Output Enable Timing Diagrams

The \overline{EN} signal will “freeze” the internal divider flip-flops on the first falling edge of CLK after its assertion. The internal divider flip-flops will maintain their state during the freeze. When \overline{EN} is deasserted (LOW), and after the next

falling edge of CLK, then the internal divider flip-flops will “unfreeze” and continue to their next state count with proper phase relationships.

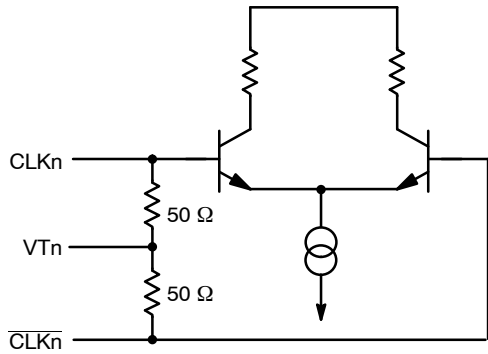

Figure 9. Input Structure

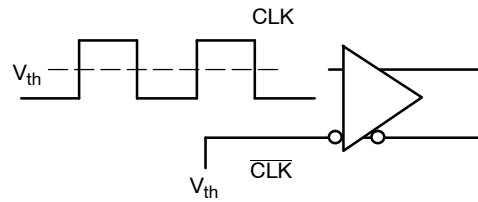

Figure 10. Differential Input Driven Single-Ended

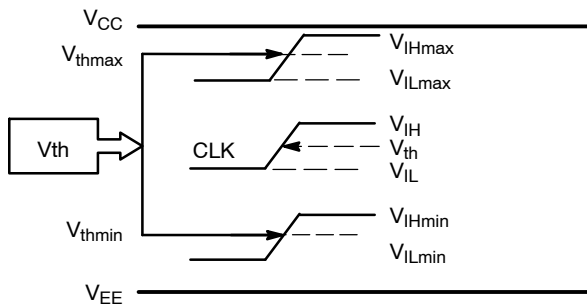

Figure 11. V_{th} Diagram

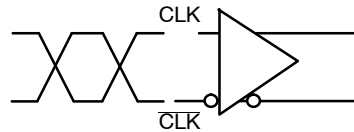

Figure 12. Differential Inputs Driven Differentially

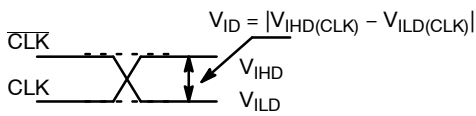

Figure 13. Differential Inputs Driven Differentially

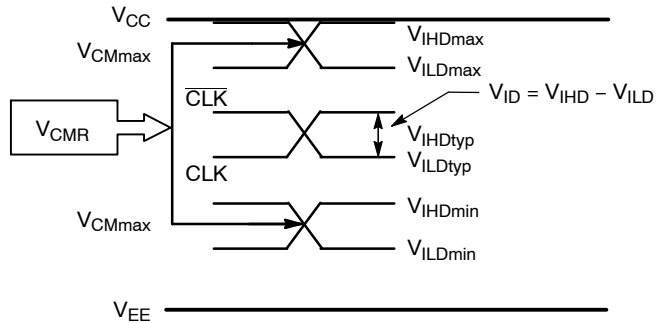
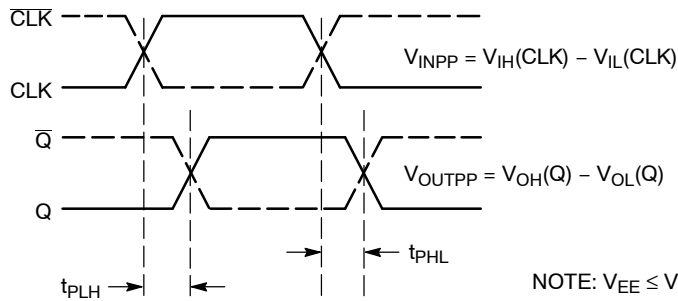

Figure 14. VCMR Diagram



NOTE: $V_{EE} \leq V_{IN} \leq V_{CC}$; $V_{IH} > V_{IL}$

Figure 15. AC Reference Measurement

NB4L339

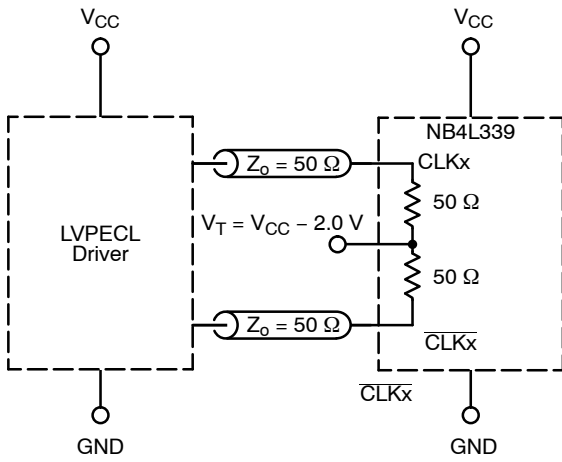

Figure 16. LVPECL Interface

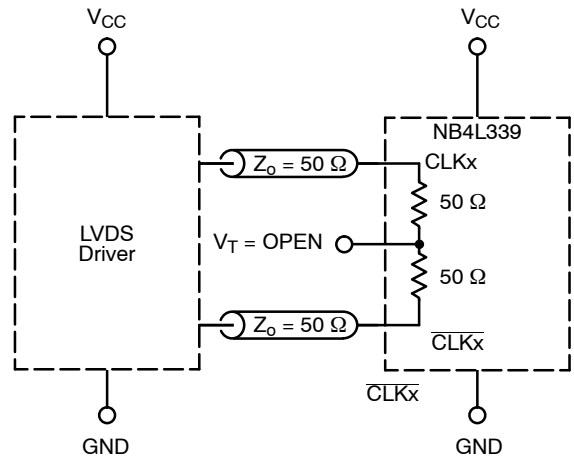

Figure 17. LVDS Interface

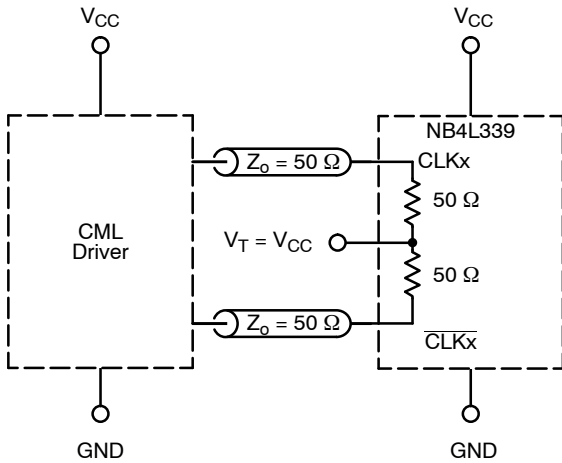

Figure 18. Standard 50 Ω Load CML Interface

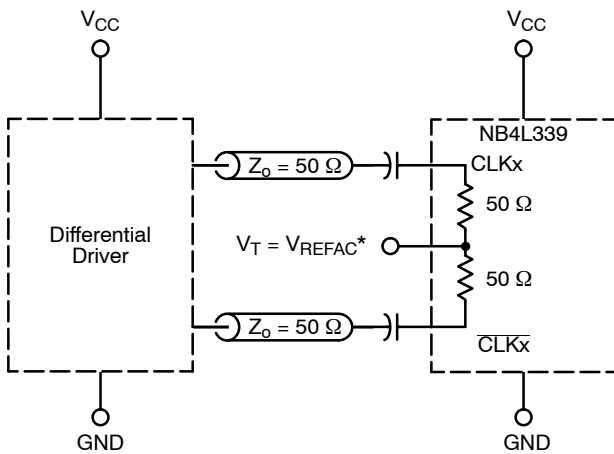

Figure 19. Capacitor-Coupled Differential Interface (V_T Connected to External V_{REFAC})

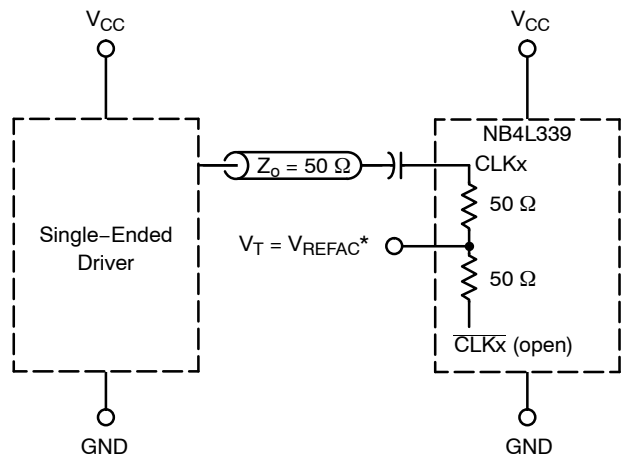

Figure 20. Capacitor-Coupled Single-Ended Interface (V_T Connected to External V_{REFAC})

* V_{REFAC} bypassed to ground with a 0.01 μ F capacitor.

NB4L339

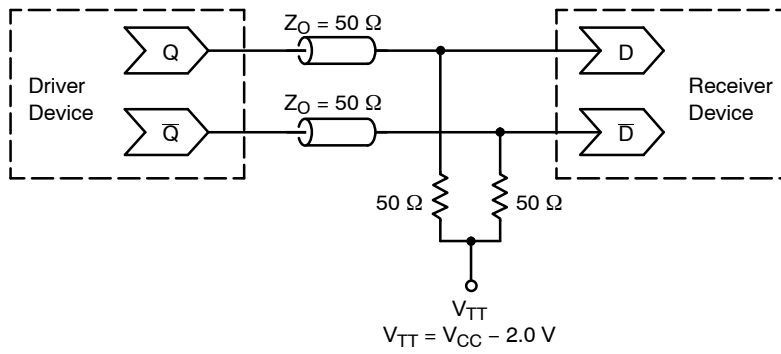

Figure 21. Typical Termination for Output Driver and Device Evaluation
 (See Application Note AND8020/D – Termination of ECL Logic Devices)

ORDERING INFORMATION

Device	Package	Shipping [†]
NB4L339MNG	QFN32 (Pb-free)	74 Units / Tray
NB4L339MNR4G	QFN32 (Pb-free)	1000 / Tape & Reel

*For additional information on our Pb-Free strategy and soldering details, please download the ON Semiconductor Soldering and Mounting Techniques Reference Manual, SOLDERRM/D.

NB4L339

PACKAGE DIMENSIONS

QFN32 5x5, 0.5 P
CASE 488AM
ISSUE O

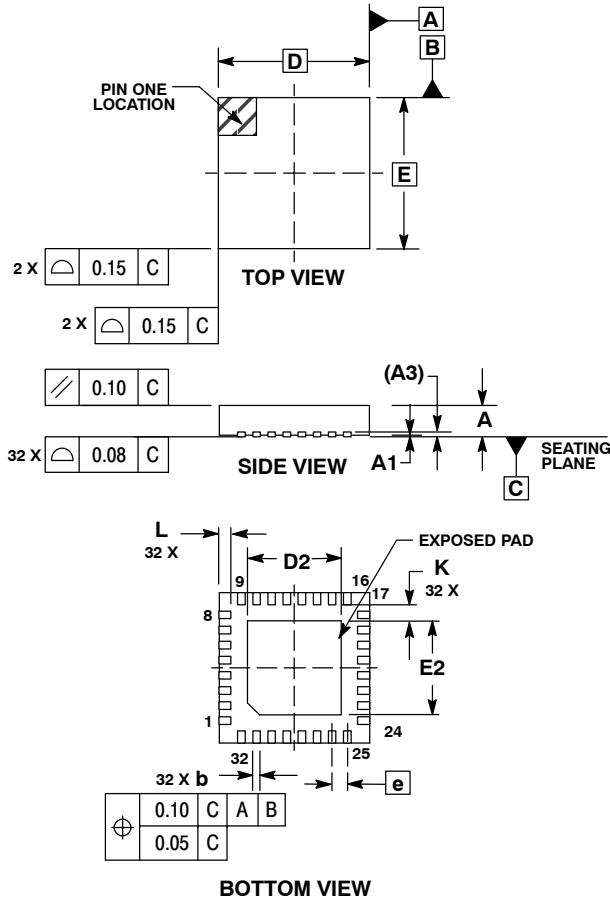

NOTES:

1. DIMENSIONS AND TOLERANCING PER ASME Y14.5M, 1994.
2. CONTROLLING DIMENSION: MILLIMETERS.
3. DIMENSION b APPLIES TO PLATED TERMINAL AND IS MEASURED BETWEEN 0.25 AND 0.30 MM TERMINAL
4. COPLANARITY APPLIES TO THE EXPOSED PAD AS WELL AS THE TERMINALS.

MILLIMETERS			
DIM	MIN	NOM	MAX
A	0.800	0.900	1.000
A1	0.000	0.025	0.050
A3	0.200 REF		
b	0.180	0.250	0.300
D	5.00 BSC		
D2	2.950	3.100	3.250
E	5.00 BSC		
E2	2.950	3.100	3.250
e	0.500 BSC		
K	0.200	---	---
L	0.300	0.400	0.500

SOLDERING FOOTPRINT*

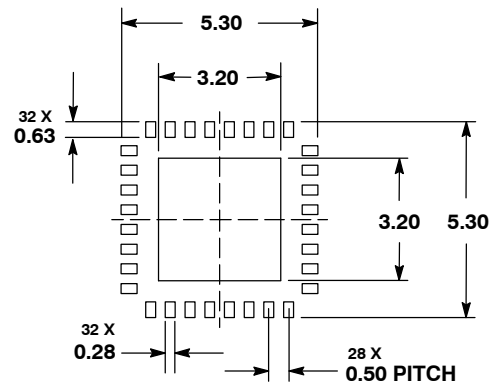

*For additional information on our Pb-Free strategy and soldering details, please download the ON Semiconductor Soldering and Mounting Techniques Reference Manual, SOLDERRM/D.

ON Semiconductor and are registered trademarks of Semiconductor Components Industries, LLC (SCILLC). SCILLC owns the rights to a number of patents, trademarks, copyrights, trade secrets, and other intellectual property. A listing of SCILLC's product/patent coverage may be accessed at www.onsemi.com/site/pdf/Patent-Marking.pdf. SCILLC reserves the right to make changes without further notice to any products herein. SCILLC makes no warranty, representation or guarantee regarding the suitability of its products for any particular purpose, nor does SCILLC assume any liability arising out of the application or use of any product or circuit, and specifically disclaims any and all liability, including without limitation special, consequential or incidental damages. "Typical" parameters which may be provided in SCILLC data sheets and/or specifications can and do vary in different applications and actual performance may vary over time. All operating parameters, including "Typicals" must be validated for each customer application by customer's technical experts. SCILLC does not convey any license under its patent rights nor the rights of others. SCILLC products are not designed, intended, or authorized for use as components in systems intended for surgical implant into the body, or other applications intended to support or sustain life, or for any other application in which the failure of the SCILLC product could create a situation where personal injury or death may occur. Should Buyer purchase or use SCILLC products for any such unintended or unauthorized application, Buyer shall indemnify and hold SCILLC and its officers, employees, subsidiaries, affiliates, and distributors harmless against all claims, costs, damages, and expenses, and reasonable attorney fees arising out of, directly or indirectly, any claim of personal injury or death associated with such unintended or unauthorized use, even if such claim alleges that SCILLC was negligent regarding the design or manufacture of the part. SCILLC is an Equal Opportunity/Affirmative Action Employer. This literature is subject to all applicable copyright laws and is not for resale in any manner.

PUBLICATION ORDERING INFORMATION

LITERATURE FULFILLMENT:
Literature Distribution Center for ON Semiconductor
P.O. Box 5163, Denver, Colorado 80217 USA
Phone: 303-675-2175 or 800-344-3860 Toll Free USA/Canada
Fax: 303-675-2176 or 800-344-3867 Toll Free USA/Canada
Email: orderlit@onsemi.com

N. American Technical Support: 800-282-9855 Toll Free USA/Canada
Europe, Middle East and Africa Technical Support:
Phone: 421 33 790 2910
Japan Customer Focus Center
Phone: 81-3-5817-1050

ON Semiconductor Website: www.onsemi.com
Order Literature: <http://www.onsemi.com/orderlit>
For additional information, please contact your local Sales Representative

Looking for pricing, stock, or lifecycle information?

Click below to explore more details on WIN SOURCE:

 [View NB4L339MNR4G on WIN SOURCE](#)

 [ON Semiconductor](#) Information

Optimize Your Supply Chain with WIN SOURCE Solutions

-  Global Sourcing Solution
-  Obsolete Management
-  Cost Control Management
-  Shortage Management
-  Alternative Solution
-  Excess Inventory Management