

LNA-IC for 800MHz / 450MHz Band Applications

FEATURES

- Low voltage operation +2.80 V typ.
- High gain 15.0 dB typ. fRX = 881.5 MHz
16.0 dB typ. fRX = 450 MHz
- Low noise figure 1.40 dB typ. fRX = 881.5 MHz
1.30 dB typ. fRX = 450 MHz
- Low distortion (IIP3 +10 MHz offset)
+10.0 dBm typ. fRX = 881.5 MHz
+10.0 dBm typ. fRX = 450 MHz
- 5 pin Plastic Small Surface Mount Package (SMINI Type)

DESCRIPTION

AN26011A is LNA-IC for 800MHz / 450MHz Band Applications.
Realizing high performance by using 0.18 μm SiGeC Bi-CMOS process($f_T = 90$ GHz, $f_{max} = 140$ GHz).
Low Gain mode is available, controlled by integrated CMOS logic circuit.
Achieving miniaturization by using small size package.

APPLICATIONS

- Cellular Phone 800MHz / 450MHz Band Application

SIMPLIFIED APPLICATION

TOP VIEW

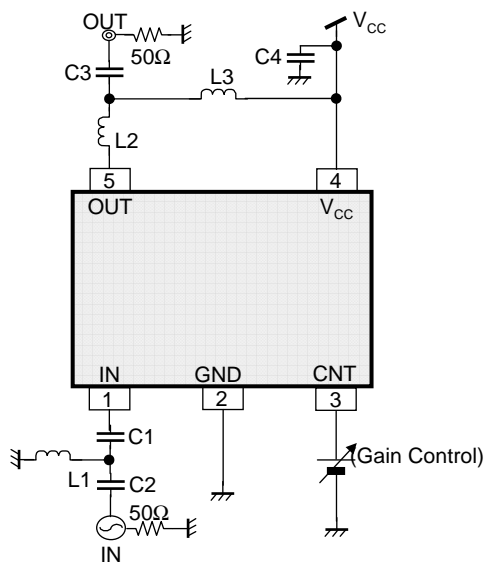

Components	Size	Value	Part Number	Vendor
L1	0603	12 nH	LQPT03TN12NH04	Murata
L2	0603	12 nH	LQPT03TN12NH04	Murata
L3	0603	10 nH	LQPT03TN10NH04	Murata
C1	0603	1000 pF	GRM033B11C102KD01	Murata
C2	0603	4.0 pF	GJM0332C1E4R0BB01D	Murata
C3	0603	4.0 pF	GJM0332C1E4R0BB01D	Murata
C4	0603	0.1 μF	GRM033B30J104KE18	Murata

Notes) This application circuit is an example. The operation of mass production set is not guaranteed. You should perform enough evaluation and verification on the design of mass production set. You are fully responsible for the incorporation of the above application circuit and information in the design of your equipment.

ABSOLUTE MAXIMUM RATINGS

Parameter	Symbol	Rating	Unit	Note
Supply voltage	V_{CC}	3.6	V	*1
Supply current	I_{CC}	18	mA	—
Operating ambient temperature	T_{opr}	-20 to +70	°C	*2
Operating junction temperature	T_j	-40 to +125	°C	*2
Storage temperature	T_{stg}	-55 to +125	°C	*2
Input Voltage Range	IN (Pin No.1)	—	V	*3
	CNT (Pin No.3)	- 0.3 to ($V_{CC}+0.3$)	V	*4
	OUT (Pin No.5)	- 0.3 to ($V_{CC}+0.3$)	V	*4
ESD	HBM (Human Body Model)	1500	V	—

Notes). This product may sustain permanent damage if subjected to conditions higher than the above stated absolute maximum rating. This rating is the maximum rating and device operating at this range is not guaranteeable as it is higher than our stated recommended operating range.

When subjected under the absolute maximum rating for a long time, the reliability of the product may be affected.

*1:The values under the condition not exceeding the above absolute maximum ratings and the power dissipation.

*2:Except for the operating ambient temperature, operating junction temperature and storage temperature, all ratings are for $T_a = 25^{\circ}C$.

*3:RF signal input pin. Do not apply more than 0 dBm to RF input.

*4:($V_{CC} + 0.3$) V must not be exceeded 3.6 V.

POWER DISSIPATION RATING

PACKAGE	θ_{JA}	PD ($T_a=25^{\circ}C$)	PD ($T_a=70^{\circ}C$)
SSMINI-5DC	833°C/W	0.12W	0.066W

Note). For the actual usage, please refer to the PD-Ta characteristics diagram in the package specification, supply voltage, load and ambient temperature conditions to ensure that there is enough margin follow the power and the thermal design does not exceed the allowable value.



CAUTION

Although this has limited built-in ESD protection circuit, but permanent damage may occur on it. Therefore, proper ESD precautions are recommended to avoid electrostatic damage to the MOS gates

RECOMMENDED OPERATING CONDITIONS

Parameter	Symbol	Min.	Typ.	Max.	Unit	Note
Supply voltage range	V_{CC}	2.65	2.8	2.95	V	*1

Note) *1: The values under the condition not exceeding the above absolute maximum ratings and the power dissipation

ELECTRICAL CHARACTERISTICS

Note) $V_{CC} = 2.80\text{ V}$, $T_a = 25^\circ\text{C} \pm 2^\circ\text{C}$, unless otherwise specified.

Performance based on application circuit 1 on page 11.

Parameter	Symbol	Condition	Limits			Unit	Note
			Min	Typ	Max		
DC electrical characteristics							
Supply current (High Gain mode)	I _{ccHS}	V _{CC} current at High Gain mode. No input signal	—	11.5	14.5	mA	—
Supply current (Low Gain mode)	I _{ccLS}	V _{CC} current at Low Gain mode. No input signal	—	0	10	μA	—
CNT current (High Gain mode)	I _{cntHS}	Current at CNT Pin. Voltage at CNT Pin = 2.80 V	—	5	35	μA	—
CNT current (Low Gain mode)	I _{cntLS}	Current at CNT Pin. Voltage at CNT Pin = 0 V	—	0	10	μA	—
CNT voltage (High Gain mode)	V _{IHS}	—	2.52	—	3.1	V	—
CNT voltage (Low Gain mode)	V _{ILS}	—	—	0	0.3	V	—

ELECTRICAL CHARACTERISTICS (continued)

Note) $V_{CC} = 2.80\text{ V}$,

$T_a = 25^\circ\text{C} \pm 2^\circ\text{C}$, $f_{RX} = 881.5\text{ MHz}$, $PRX = -30\text{ dBm}$, CW unless otherwise specified.

Performance based on application circuit 1 on page 11.

Parameter	Symbol	Condition	Limits			Unit	Note
			Min	Typ	Max		
LNA AC electrical characteristics (High Gain Mode)							
Power Gain HG	GHS	—	13.0	15.0	17.0	dB	—
IIP3 +10 MHz offset	IIP3S	f1 = f _{RX} + 10 MHz f2 = f _{RX} + 20 MHz Input 2 signals (f1, f2)	6.0	10.0	—	dBm	—
LNA AC electrical characteristics (Low Gain Mode)							
Power Gain LG	GLS	PRX = -20 dBm	-5.0	-3.0	-1.5	dB	—

APPLICATION INFORMATION
REFERENCE VALUES FOR DESIGN

Note) $V_{cc} = 2.80\text{ V}$

$T_a = 25^{\circ}\text{C} \pm 2^{\circ}\text{C}$, $f_{RXa} = 869\text{ MHz}, 881.5\text{ MHz}, 894\text{ MHz}$, $PRXa = -30\text{ dBm}$, CW unless otherwise specified.

Performance based on application circuit 1 on page 11.

Parameter	Symbol	Conditions	Reference values			Unit	Note
			Min	Typ	Max		
LNA AC electrical characteristics (High Gain Mode)							
Power Gain HG	GHa	—	13.0	15.0	17.0	dB	*1
Noise Figure HG	NFHa	—	—	1.5	2.1	dB	*1,*2
IIP3 +10 MHz offset HG	IIP3H1a	$f1 = f_{RXa} + 10\text{ MHz}$ $f2 = f_{RXa} + 20\text{ MHz}$ Input 2 signals (f1, f2)	6.0	10.0	—	dBm	*1
IIP3 -10 MHz offset HG	IIP3H2a	$f1 = f_{RXa} - 10\text{ MHz}$ $f2 = f_{RXa} - 20\text{ MHz}$ Input 2 signals (f1, f2)	6.0	10.0	—	dBm	*1
Input P1dB	IP1dBHa	—	-10.0	-6.0	—	dBm	*1
Reverse Isolation HG	ISOHa	—	—	-22.0	-18.0	dB	*1
Input Return Loss HG	S11Ha	—	5.5	7.5	—	dB	*1
Output Return Loss HG	S22Ha	—	7.0	9.0	—	dB	*1
LNA AC electrical characteristics (Low Gain Mode)							
Power Gain LG	GLa	$PRXa = -20\text{ dBm}$	-5.0	-3.0	-1.5	dB	*1
Noise Figure LG	NFLa	—	—	3.0	5.5	dB	*1
IIP3 +10 MHz offset LG	IIP3L1a	$f1 = f_{RXa} + 10\text{ MHz}$ $f2 = f_{RXa} + 20\text{ MHz}$ $PRXa = -15\text{ dBm}$ Input 2 signals (f1, f2)	17.0	20.0	—	dBm	*1
Reverse Isolation LG	ISOLa	—	-5.0	-3.0	-1.5	dB	*1
Input Return Loss LG	S11La	—	7.0	9.0	—	dB	*1
Output Return Loss LG	S22La	—	5.5	7.5	—	dB	*1

Note) *1 : Checked by design, not production tested.

*2 : RF input Connector & substrate loss (0.1 dB) included.

APPLICATION INFORMATION (continued)

REFERENCE VALUES FOR DESIGN (continued)

Note) $V_{cc} = 2.80\text{ V}$

$T_a = 25^{\circ}\text{C} \pm 2^{\circ}\text{C}$, $f_{RXa} = 869\text{ MHz}$, 881.5 MHz , 894 MHz , $PRXa = -30\text{ dBm}$, CW unless otherwise specified.

Performance based on application circuit 2 on page 11.

Parameter	Symbol	Conditions	Reference values			Unit	Note
			Min	Typ	Max		
LNA AC electrical characteristics (High Gain Mode)							
Power Gain HG	GHb	—	12.0	14.0	16.0	dB	*1
Noise Figure HG	NFHb	—	—	1.4	2.0	dB	*1,*2
IIP3 +10 MHz offset HG	IIP3H1b	$f_1 = f_{RXa} + 10\text{ MHz}$ $f_2 = f_{RXa} + 20\text{ MHz}$ Input 2 signals (f_1, f_2)	7.5	11.5	—	dBm	*1
IIP3 -10 MHz offset HG	IIP3H2b	$f_1 = f_{RXa} - 10\text{ MHz}$ $f_2 = f_{RXa} - 20\text{ MHz}$ Input 2 signals (f_1, f_2)	7.5	11.5	—	dBm	*1
Input P1dB	IP1dBHb	—	-9.0	-5.0	—	dBm	*1
Reverse Isolation HG	ISOHb	—	—	-22.0	-18.0	dB	*1
Input Return Loss HG	S11Hb	—	2.5	4.0	—	dB	*1
Output Return Loss HG	S22Hb	—	5.5	7.5	—	dB	*1
LNA AC electrical characteristics (Low Gain Mode)							
Power Gain LG	GLb	$PRXa = -20\text{ dBm}$	-6.0	-4.0	-2.5	dB	*1
Noise Figure LG	NFLb	—	—	4.0	6.5	dB	*1
IIP3 +10 MHz offset LG	IIP3L1b	$f_1 = f_{RXa} + 10\text{ MHz}$ $f_2 = f_{RXa} + 20\text{ MHz}$ $PRXa = -15\text{ dBm}$ Input 2 signals (f_1, f_2)	17.0	20.0	—	dBm	*1
Reverse Isolation LG	ISOLb	—	-6.0	-4.0	-2.5	dB	*1
Input Return Loss LG	S11Lb	—	2.5	5.0	—	dB	*1
Output Return Loss LG	S22Lb	—	2.5	5.0	—	dB	*1

Note) *1 : Checked by design, not production tested.

*2 : RF input Connector & substrate loss (0.1 dB) included.

APPLICATION INFORMATION (continued)

REFERENCE VALUES FOR DESIGN (continued)

Note) $V_{cc} = 2.80\text{ V}$

$T_a = 25^\circ\text{C} \pm 2^\circ\text{C}$, $f_{RXb} = 440\text{ MHz}$, 450 MHz , 460 MHz , $PRXb = -30\text{ dBm}$, CW unless otherwise specified.

Performance based on application circuit 3 on page 12.

Parameter	Symbol	Conditions	Reference values			Unit	Note
			Min	Typ	Max		
LNA AC electrical characteristics (High Gain Mode)							
Power Gain HG	GHc	—	14.0	16.0	18.0	dB	*1
Noise Figure HG	NFHc	—	—	1.4	2.1	dB	*1,*2
IIP3 +10 MHz offset HG	IIP3H1c	$f1 = f_{RXb} + 10\text{ MHz}$ $f2 = f_{RXb} + 20\text{ MHz}$ Input 2 signals ($f1, f2$)	6.5	10.0	—	dBm	*1
IIP3 -10 MHz offset HG	IIP3H2c	$f1 = f_{RXb} - 10\text{ MHz}$ $f2 = f_{RXb} - 20\text{ MHz}$ Input 2 signals ($f1, f2$)	6.5	10.0	—	dBm	*1
Input P1dB	IP1dBHc	—	-11.0	-7.0	—	dBm	*1
Reverse Isolation HG	ISOHc	—	—	-24.0	-20.0	dB	*1
Input Return Loss HG	S11Hc	—	5.5	7.5	—	dB	*1
Output Return Loss HG	S22Hc	—	5.0	7.5	—	dB	*1
LNA AC electrical characteristics (Low Gain Mode)							
Power Gain LG	GLc	$PRXb = -20\text{ dBm}$	-4.5	-3.0	-1.5	dB	*1
Noise Figure LG	NFLc	—	—	3.0	5.0	dB	*1
IIP3 +10 MHz offset LG	IIP3L1c	$f1 = f_{RXb} + 10\text{ MHz}$ $f2 = f_{RXb} + 20\text{ MHz}$ $PRXb = -10\text{ dBm}$ Input 2 signals ($f1, f2$)	22.0	25.0	—	dBm	*1
Reverse Isolation LG	ISOLc	—	-4.5	-3.0	-1.5	dB	*1
Input Return Loss LG	S11Lc	—	8.5	10.0	—	dB	*1
Output Return Loss LG	S22Lc	—	12.0	15.0	—	dB	*1

Note) *1 : Checked by design, not production tested.

*2 : RF input Connector & substrate loss (0.1 dB) included.

APPLICATION INFORMATION (continued)

REFERENCE VALUES FOR DESIGN (continued)

Note) $V_{cc} = 2.65\text{ V to }2.95\text{ V}$

$T_a = -20^\circ\text{C to }70^\circ\text{C}$, CW unless otherwise specified.

Performance based on application circuit 1 on page 11.

Parameter	Symbol	Conditions	Reference values			Unit	Note
			Min	Typ	Max		
DC electrical characteristics							
Supply current (High Gain mode)	I _{ccHT}	V _{cc} current at High Gain mode No input signal	—	11.5	15.5	mA	*1
Supply current (Low Gain mode)	I _{ccLT}	V _{cc} current at Low Gain mode No input signal	—	0	20	μA	*1
CNT current (High Gain mode)	I _{cntHT}	Current at CNT Pin Voltage at CNT Pin = 2.80 V	—	5	45	μA	*1
CNT current (Low Gain mode)	I _{cntLT}	Current at CNT Pin Voltage at CNT Pin = 0 V	—	0	20	μA	*1

Note) *1 : Checked by design, not production tested.

APPLICATION INFORMATION (continued)

REFERENCE VALUES FOR DESIGN (continued)

Note) $V_{cc} = 2.65\text{ V to }2.95\text{ V}$

$T_a = -20^\circ\text{C to }70^\circ\text{C}$, $f_{RXa} = 869\text{ MHz, }881.5\text{ MHz, }894\text{ MHz}$, $PRXa = -30\text{ dBm}$, CW unless otherwise specified.

Performance based on application circuit 1 on page 11.

Parameter	Symbol	Conditions	Reference values			Unit	Note
			Min	Typ	Max		
LNA AC electrical characteristics (High Gain Mode)							
Power Gain HG	GHTa	—	12.0	15.0	18.0	dB	*1
Noise Figure HG	NFHTa	—	—	1.5	2.4	dB	*1,*2
IIP3 +10 MHz offset HG	IIP3H1Ta	f1 = fRXa + 10 MHz f2 = fRXa + 20 MHz Input 2 signals (f1, f2)	5.0	10.0	—	dBm	*1
IIP3 -10 MHz offset HG	IIP3H2Ta	f1 = fRXa - 10 MHz f2 = fRXa - 20 MHz Input 2 signals (f1, f2)	5.0	10.0	—	dBm	*1
Input P1dB	IP1dBHTa	—	-15.0	-6.0	—	dBm	*1
LNA AC electrical characteristics (Low Gain Mode)							
Power Gain LG	GLTa	PRXa = - 20 dBm	-5.5	-3.0	-1.0	dB	*1
Noise Figure LG	NFLTa	—	—	3.0	7.0	dB	*1
IIP3 +10 MHz offset LG	IIP3LT1a	f1 = fRXa + 10 MHz f2 = fRXa + 20 MHz PRXa = - 15 dBm Input 2 signals (f1, f2)	15.0	20.0	—	dBm	*1

Note) *1 : Checked by design, not production tested.

*2 : RF input Connector & substrate loss (0.1 dB) included.

APPLICATION INFORMATION (continued)

REFERENCE VALUES FOR DESIGN (continued)

Note) $V_{cc} = 2.65\text{ V to }2.95\text{ V}$

$T_a = -20^\circ\text{C to }70^\circ\text{C}$, $f_{RXa} = 869\text{ MHz, }881.5\text{ MHz, }894\text{ MHz}$, $PRXa = -30\text{ dBm}$, CW unless otherwise specified.

Performance based on application circuit 2 on page 11.

Parameter	Symbol	Conditions	Reference values			Unit	Note
			Min	Typ	Max		
LNA AC electrical characteristics (High Gain Mode)							
Power Gain HG	GHTb	—	11.0	14.0	17.0	dB	*1
Noise Figure HG	NFHTb	—	—	1.4	2.3	dB	*1,*2
IIP3 +10 MHz offset HG	IIP3H1Tb	f1 = $f_{RXa} + 10\text{ MHz}$ f2 = $f_{RXa} + 20\text{ MHz}$ Input 2 signals (f1, f2)	6.5	11.5	—	dBm	*1
IIP3 -10 MHz offset HG	IIP3H2Tb	f1 = $f_{RXa} - 10\text{ MHz}$ f2 = $f_{RXa} - 20\text{ MHz}$ Input 2 signals (f1, f2)	6.5	11.5	—	dBm	*1
Input P1dB	IP1dBHTb	—	-14.0	-5.0	—	dBm	*1
LNA AC electrical characteristics (Low Gain Mode)							
Power Gain LG	GLTb	$PRXa = -20\text{ dBm}$	-6.5	-4.0	-2.0	dB	*1
Noise Figure LG	NFLTb	—	—	4.0	8.0	dB	*1
IIP3 +10 MHz offset LG	IIP3LT1b	f1 = $f_{RXa} + 10\text{ MHz}$ f2 = $f_{RXa} + 20\text{ MHz}$ $PRXa = -15\text{ dBm}$ Input 2 signals (f1, f2)	15.0	20.0	—	dBm	*1

Note) *1 : Checked by design, not production tested.

*2 : RF input Connector & substrate loss (0.1 dB) included.

APPLICATION INFORMATION (continued)

REFERENCE VALUES FOR DESIGN (continued)

Note) $V_{cc} = 2.65\text{ V to }2.95\text{ V}$

$T_a = -20^\circ\text{C to }70^\circ\text{C}$, $f_{RXb} = 440\text{ MHz, }450\text{ MHz, }460\text{ MHz}$, $PRXb = -30\text{ dBm}$, CW unless otherwise specified.

Performance based on application circuit 3 on page 12.

Parameter	Symbol	Conditions	Reference values			Unit	Note
			Min	Typ	Max		
LNA AC electrical characteristics (High Gain Mode)							
Power Gain HG	GHTc	—	13.0	16.0	19.0	dB	*1
Noise Figure HG	NFHTc	—	—	1.4	2.4	dB	*1,*2
IIP3 +10 MHz offset HG	IIP3H1Tc	$f1 = f_{RXb} + 10\text{ MHz}$ $f2 = f_{RXb} + 20\text{ MHz}$ Input 2 signals (f1, f2)	5.0	10.0	—	dBm	*1
IIP3 -10 MHz offset HG	IIP3H2Tc	$f1 = f_{RXb} - 10\text{ MHz}$ $f2 = f_{RXb} - 20\text{ MHz}$ Input 2 signals (f1, f2)	5.0	10.0	—	dBm	*1
Input P1dB	IP1dBHTc	—	-16.0	-7.0	—	dBm	*1
LNA AC electrical characteristics (Low Gain Mode)							
Power Gain LG	GLTc	$PRXb = -20\text{ dBm}$	-5.0	-3.0	-1.0	dB	*1
Noise Figure LG	NFLTc	—	—	3.0	6.5	dB	*1
IIP3 +10 MHz offset LG	IIP3LT1c	$f1 = f_{RXb} + 10\text{ MHz}$ $f2 = f_{RXb} + 20\text{ MHz}$ $PRXb = -10\text{ dBm}$ Input 2 signals (f1, f2)	20.0	25.0	—	dBm	*1

Note) *1 : Checked by design, not production tested.

*2 : RF input Connector & substrate loss (0.1 dB) included.

APPLICATION INFORMATION (Continued)
APPLICATION CIRCUIT

[Application Circuit 1 for 800 MHz Band]

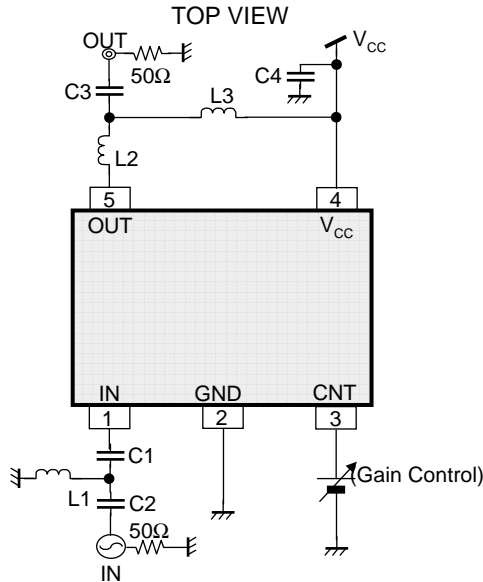

Components	Size	Value	Part Number	Vendor
L1	0603	12 nH	LQPT03TN12NH04	Murata
L2	0603	12 nH	LQPT03TN12NH04	Murata
L3	0603	10 nH	LQPT03TN10NH04	Murata
C1	0603	1000 pF	GRM033B11C102KD01	Murata
C2	0603	4.0 pF	GJM0332C1E4R0BB01D	Murata
C3	0603	4.0 pF	GJM0332C1E4R0BB01D	Murata
C4	0603	0.1 μF	GRM033B30J104KE18	Murata

Notes) This application circuit is an example. The operation of mass production set is not guaranteed. You should perform enough evaluation and verification on the design of mass production set. You are fully responsible for the incorporation of the above application circuit and information in the design of your equipment.

[Application Circuit 2 for 800 MHz Band]

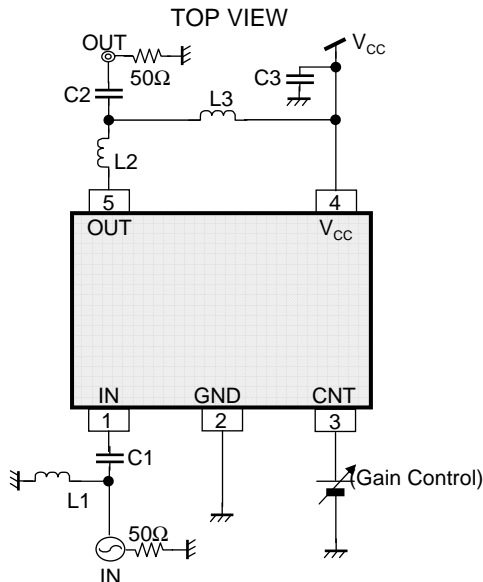

Components	Size	Value	Part Number	Vendor
L1	0603	56 nH	LQP03T56NJ04	Murata
L2	0603	12 nH	LQPT03TN12NH04	Murata
L3	0603	10 nH	LQPT03TN10NH04	Murata
C1	0603	1000 pF	GRM033B11C102KD01	Murata
C2	0603	4.0 pF	GJM0332C1E4R0BB01D	Murata
C3	0603	0.1 μF	GRM033B30J104KE18	Murata

Notes) This application circuit is an example. The operation of mass production set is not guaranteed. You should perform enough evaluation and verification on the design of mass production set. You are fully responsible for the incorporation of the above application circuit and information in the design of your equipment.

APPLICATION INFORMATION (Continued)

APPLICATION CIRCUIT (Continued)

[Application Circuit 3 for 450 MHz Band]

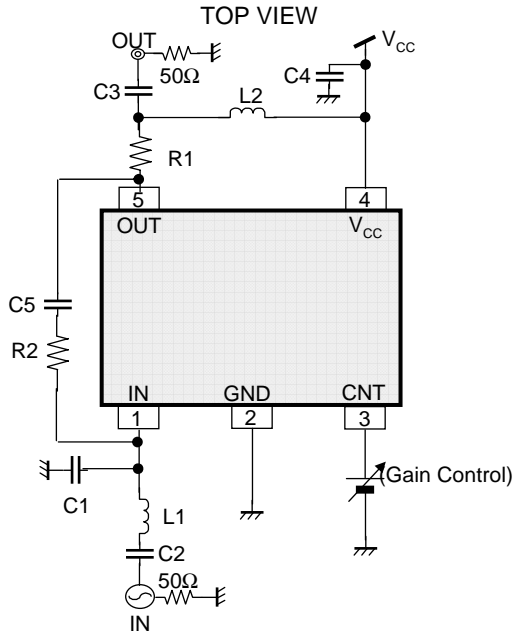

Components	Size	Value	Part Number	Vendor
L1	0603	12 nH	LQPT03TN12NH04	Murata
L2	0603	22 nH	LQP03T22NH04	Murata
R1	1005	10 Ω	ERJ2GEJ100X	Panasonic
R2	1005	1.3 kΩ	ERJ2GEJ132X	Panasonic
C1	0603	2.0 pF	GJM0334C1E2R0BB01	Murata
C2	0603	1000 pF	GRM033B11C102KD01	Murata
C3	0603	4.5 pF	GJM0332C1E4R5BB01D	Murata
C4	0603	0.1 μF	GRM033B30J104KE18	Murata
C5	1005	0.5 pF	ECJ0EC1H0R5C	Panasonic

Notes) This application circuit is an example. The operation of mass production set is not guaranteed. You should perform enough evaluation and verification on the design of mass production set. You are fully responsible for the incorporation of the above application circuit and information in the design of your equipment.

PIN CONFIGURATION

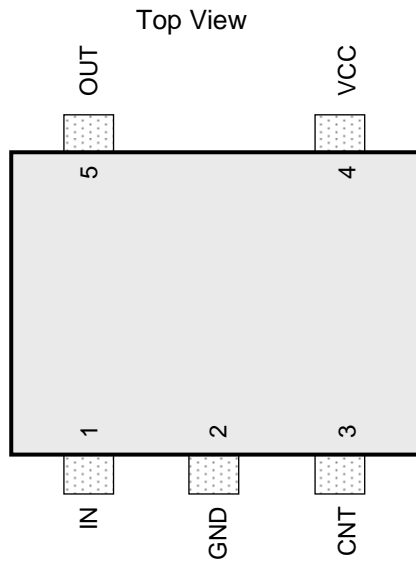

PIN FUNCTIONS

Pin No.	Pin name	Type	Description
1	IN	Input	RF Input
2	GND	Ground	GND
3	CNT	Input	High Gain / Low Gain switch L: Low Gain Mode H: High Gain Mode
4	VCC	Power Supply	V _{CC}
5	OUT	Output	RF Output

FUNCTIONAL BLOCK DIAGRAM

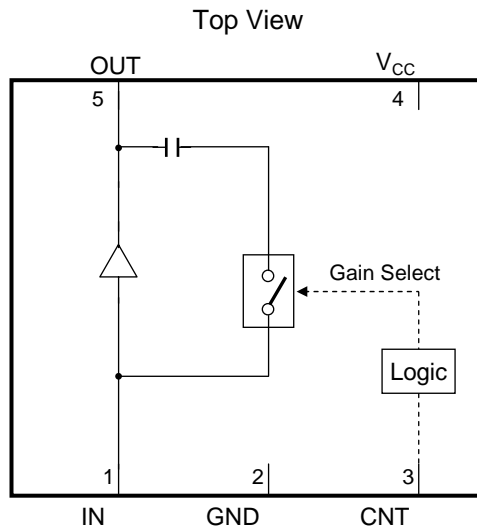

Notes) This circuit and these circuit constants show an example and do not guarantee the design as a mass-production set. This block diagram is for explaining functions. The part of the block diagram may be omitted, or it may be simplified.

PACKAGE INFORMATION (Reference Data)

Package Code:SSMINI-5DC

Unit:mm

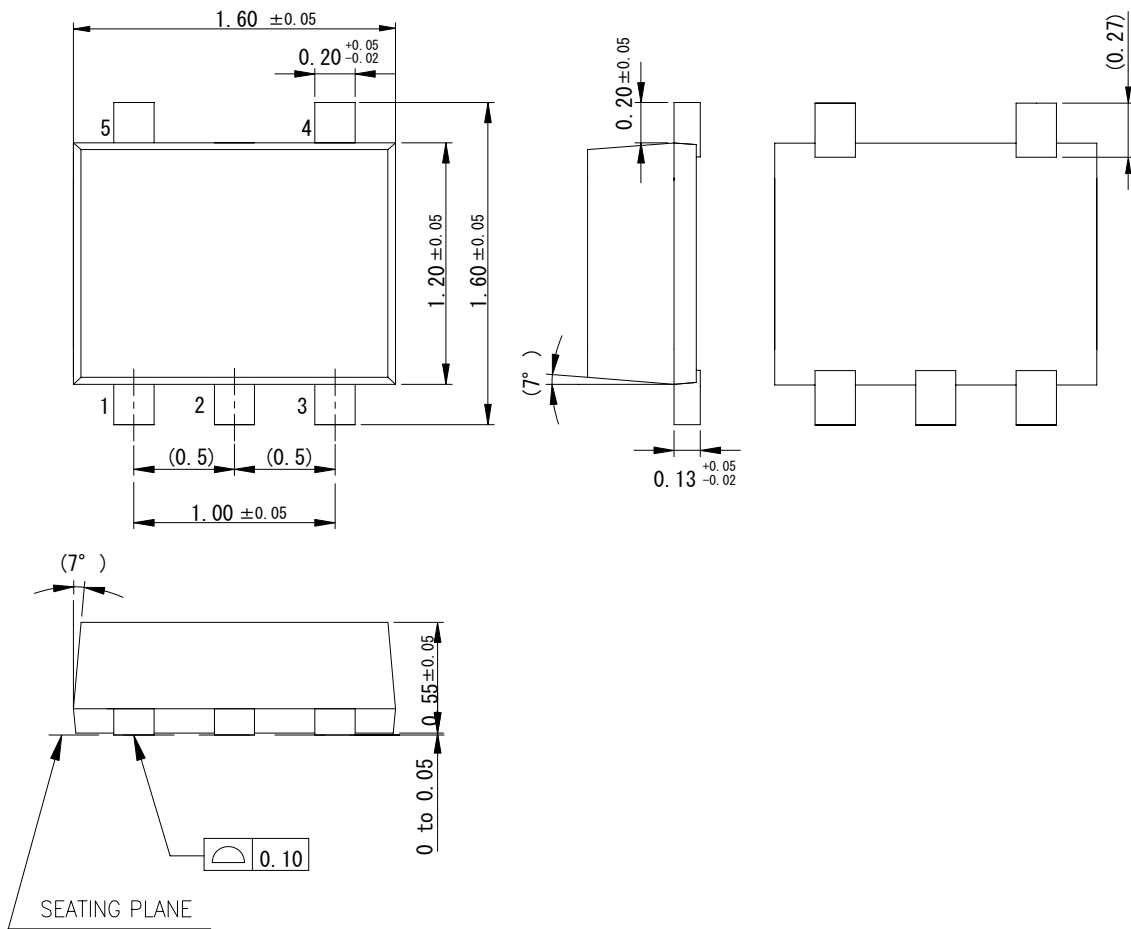

Body Material	: Br / Sb Free Epoxy Resin
Lead Material	: Cu Alloy
Lead Finish Method	: SnBi Plating

IMPORTANT NOTICE

1. The products and product specifications described in this book are subject to change without notice for modification and/or improvement. At the final stage of your design, purchasing, or use of the products, therefore, ask for the most up-to-date Product Standards in advance to make sure that the latest specifications satisfy your requirements.

2. When using the LSI for new models, verify the safety including the long-term reliability for each product.

3. When the application system is designed by using this LSI, be sure to confirm notes in this book.
Be sure to read the notes to descriptions and the usage notes in the book.

4. The technical information described in this book is intended only to show the main characteristics and application circuit examples of the products. No license is granted in and to any intellectual property right or other right owned by Panasonic Corporation or any other company. Therefore, no responsibility is assumed by our company as to the infringement upon any such right owned by any other company which may arise as a result of the use of technical information de-scribed in this book.

5. This book may be not reprinted or reproduced whether wholly or partially, without the prior written permission of our company.

6. This LSI is intended to be used for general electronic equipment [880 MHz / 450 MHz Band Applications].
Consult our sales staff in advance for information on the following applications: Special applications in which exceptional quality and reliability are required, or if the failure or malfunction of this LSI may directly jeopardize life or harm the human body.
Any applications other than the standard applications intended.
 - (1) Space appliance (such as artificial satellite, and rocket)
 - (2) Traffic control equipment (such as for automobile, airplane, train, and ship)
 - (3) Medical equipment for life support
 - (4) Submarine transponder
 - (5) Control equipment for power plant
 - (6) Disaster prevention and security device
 - (7) Weapon
 - (8) Others : Applications of which reliability equivalent to (1) to (7) is required
 It is to be understood that our company shall not be held responsible for any damage incurred as a result of or in connection with your using the LSI described in this book for any special application, unless our company agrees to your using the LSI in this book for any special application.

7. This LSI is neither designed nor intended for use in automotive applications or environments unless the specific product is designated by our company as compliant with the ISO/TS 16949 requirements.
Our company shall not be held responsible for any damage incurred by you or any third party as a result of or in connection with your using the LSI in automotive application, unless our company agrees to your using the LSI in this book for such application.

8. If any of the products or technical information described in this book is to be exported or provided to non-residents, the laws and regulations of the exporting country, especially, those with regard to security export control, must be observed.

9. Please use this product in compliance with all applicable laws and regulations that regulate the inclusion or use of controlled substances, including without limitation, the EU RoHS Directive. Our company shall not be held responsible for any damage incurred as a result of your using the LSI not complying with the applicable laws and regulations.

USAGE NOTES

1. When designing your equipment, comply with the range of absolute maximum rating and the guaranteed operating conditions (operating power supply voltage and operating environment etc.). Especially, please be careful not to exceed the range of absolute maximum rating on the transient state, such as power-on, power-off and mode-switching. Otherwise, we will not be liable for any defect which may arise later in your equipment.

Even when the products are used within the guaranteed values, take into the consideration of incidence of break down and failure mode, possible to occur to semiconductor products. Measures on the systems such as redundant design, arresting the spread of fire or preventing glitch are recommended in order to prevent physical injury, fire, social damages, for example, by using the products.

2. Comply with the instructions for use in order to prevent breakdown and characteristics change due to external factors (ESD, EOS, thermal stress and mechanical stress) at the time of handling, mounting or at customer's process. When using products for which damp-proof packing is required, satisfy the conditions, such as shelf life and the elapsed time since first opening the packages.
3. Pay attention to the direction of LSI. When mounting it in the wrong direction onto the PCB (printed-circuit-board), it might smoke or ignite.
4. Pay attention in the PCB (printed-circuit-board) pattern layout in order to prevent damage due to short circuit between pins. In addition, refer to the Pin Description for the pin configuration.
5. Perform a visual inspection on the PCB before applying power, otherwise damage might happen due to problems such as a solder-bridge between the pins of the semiconductor device. Also, perform a full technical verification on the assembly quality, because the same damage possibly can happen due to conductive substances, such as solder ball, that adhere to the LSI during transportation.
6. Take notice in the use of this product that it might break or occasionally smoke when an abnormal state occurs such as output pin-VCC short (Power supply fault), output pin-GND short (Ground fault), or output-to-output-pin short (load short) .

And, safety measures such as an installation of fuses are recommended because the extent of the above-mentioned damage and smoke emission will depend on the current capability of the power supply.

utions in using the technical information and scribed in this book

s book is to be exported or provided to non-residents, the laws and
rd to security export control, must be observed.

ly to show the main characteristics and application circuit examples
roperty right or other right owned by Panasonic Corporation or any
company as to the infringement upon any such right owned by any
l information described in this book.

or general applications (such as office equipment, communications
r for specific applications as expressly stated in this book.

ng applications:

tive equipment, traffic signaling equipment, combustion equipment,
quality and reliability are required, or if the failure or malfunction of
ody.

nsible for any damage incurred as a result of or in connection with
pplication, unless our company agrees to your using the products in

k are subject to change without notice for modification and/or im-
use of the products, therefore, ask for the most up-to-date Product
atisfy your requirements.

bsolute maximum rating and the guaranteed operating conditions
(.). Especially, please be careful not to exceed the range of absolute
er-off and mode-switching. Otherwise, we will not be liable for any



take into the consideration of incidence of break down and failure
n the systems such as redundant design, arresting the spread of fire
al injury, fire, social damages, for example, by using the products.

own and characteristics change due to external factors (ESD, EOS,
mounting or at customer's process. When using products for which
shelf life and the elapsed time since first opening the packages.

partially, without the prior written permission of our company.

Looking for pricing, stock, or lifecycle information?

Click below to explore more details on WIN SOURCE:

-  [View AN26011A on WIN SOURCE](#)
-  [Panasonic Information](#)

Optimize Your Supply Chain with WIN SOURCE Solutions

-  Global Sourcing Solution
-  Obsolete Management
-  Cost Control Management
-  Shortage Management
-  Alternative Solution
-  Excess Inventory Management