



**THE DATASHEET OF  
IDT74FCT810CTSO**





# FAST CMOS BUFFER/CLOCK DRIVER

## IDT74FCT810BT/CT

### FEATURES:

- 0.5 MICRON CMOS Technology
- Guaranteed low skew < 600ps (max.)
- Very low duty cycle distortion < 700ps (max.)
- Low CMOS levels
- TTL compatible inputs and outputs
- TTL level output voltage swings
- High drive: -32mA I<sub>OH</sub>, +48mA I<sub>OL</sub>
- Two independent output banks with 3-state control:
  - One 1:5 inverting bank
  - One 1:5 non-inverting bank
- Available in QSOP, SSOP, and SOIC packages

### DESCRIPTION:

The 74FCT810T is a dual bank inverting/ non-inverting clock driver built using advanced dual metal CMOS technology. It consists of two banks of drivers, one inverting and one non-inverting. Each bank drives five output buffers from a standard TTL-compatible input. The FCT810T has low output skew, pulse skew and package skew. Inputs are designed with hysteresis circuitry for improved noise immunity. The outputs are designed with TTL output levels and controlled edge rates to reduce signal noise. The part has multiple grounds, minimizing the effects of ground inductance.

### FUNCTIONAL BLOCK DIAGRAM

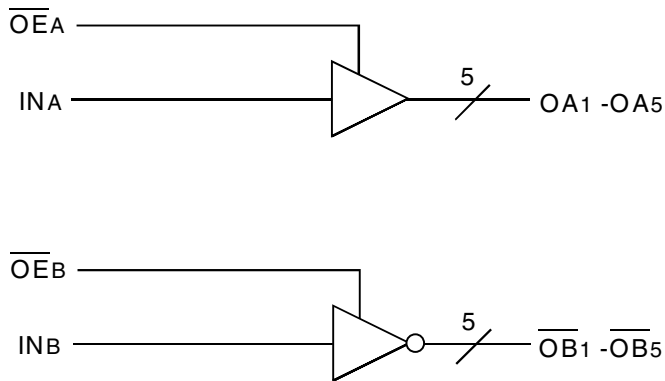

### PIN CONFIGURATION

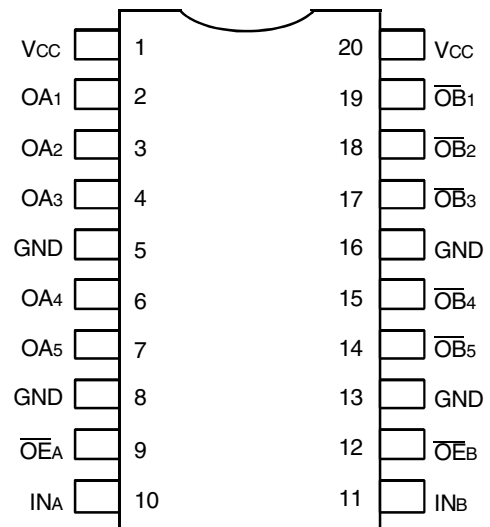

QSOP/ SOIC/ SSOP  
TOP VIEW

The IDT logo is a registered trademark of Integrated Device Technology, Inc.

### ABSOLUTE MAXIMUM RATINGS<sup>(1)</sup>

Symbol	Description	Max	Unit
V <sub>TERM</sub>	Terminal Voltage with Respect to GND	-0.5 to +7	V
T <sub>STG</sub>	Storage Temperature	-65 to +150	°C
I <sub>OUT</sub>	DC Output Current	-60 to +120	mA

**NOTE:**

- Stresses greater than those listed under ABSOLUTE MAXIMUM RATINGS may cause permanent damage to the device. This is a stress rating only and functional operation of the device at these or any other conditions above those indicated in the operational sections of this specification is not implied. Exposure to absolute maximum rating conditions for extended periods may affect reliability.

### CAPACITANCE (T<sub>A</sub> = +25°C, f = 1.0MHz)

Symbol	Parameter <sup>(1)</sup>	Conditions	Typ.	Max.	Unit
C <sub>IN</sub>	Input Capacitance	V <sub>IN</sub> = 0V	4.5	6	pF
C <sub>OUT</sub>	Output Capacitance	V <sub>OUT</sub> = 0V	5.5	8	pF

**NOTE:**

- This parameter is measured at characterization but not tested.

### PIN DESCRIPTION

Pin Names	Description
OEA, OEB	3-State Output-Enable Inputs (Active LOW)
INA, INB	Clock Inputs
OAX, OBX	Clock Outputs

### DC ELECTRICAL CHARACTERISTICS OVER OPERATING RANGE

Following Conditions Apply Unless Otherwise Specified:

Commercial: T<sub>A</sub> = 0°C to +70°C, V<sub>CC</sub> = 5V ± 5%

Symbol	Parameter	Test Conditions <sup>(1)</sup>	Min.	Typ. <sup>(2)</sup>	Max.	Unit	
V <sub>IH</sub>	Input HIGH Level (Input pins)	Guaranteed Logic HIGH Level	2	—	—	V	
V <sub>IL</sub>	Input LOW Level	Guaranteed Logic LOW Level	—	—	0.8	V	
I <sub>IH</sub>	Input HIGH Current (Input pins)	V <sub>CC</sub> = Max., V <sub>I</sub> = 2.7V	—	—	±1	μA	
I <sub>IL</sub>	Input LOW Current (Input pins)	V <sub>CC</sub> = Max., V <sub>I</sub> = 0.5V	—	—	±1	μA	
I <sub>OZH</sub>	High Impedance Output Current (3-State Output pins)	V <sub>CC</sub> = Max., V <sub>O</sub> = 2.7V	—	—	±1	μA	
I <sub>OZL</sub>			V <sub>O</sub> = 0.5V	—	—		±1
I <sub>I</sub>	Input HIGH Current	V <sub>CC</sub> = Max., V <sub>I</sub> = V <sub>CC</sub> (Max.)	—	—	±1	μA	
V <sub>IK</sub>	Clamp Diode Voltage	V <sub>CC</sub> = Min., I <sub>IN</sub> = -18mA	—	-0.7	-1.2	V	
I <sub>OS</sub>	Short Circuit Current	V <sub>CC</sub> = Max., V <sub>O</sub> = GND <sup>(3)</sup>	-60	-120	-225	mA	
V <sub>OH</sub>	Output HIGH Voltage	V <sub>CC</sub> = Min., V <sub>IN</sub> = V <sub>IH</sub> or V <sub>IL</sub>	I <sub>OH</sub> = -15mA	2.4	3.3	—	V
			I <sub>OH</sub> = -32mA <sup>(4)</sup>	2	3		
V <sub>OL</sub>	Output LOW Voltage	V <sub>CC</sub> = Min., V <sub>IN</sub> = V <sub>IH</sub> or V <sub>IL</sub>	—	0.3	0.55	—	V
I <sub>OFF</sub>	Input/Output Power Off Leakage	V <sub>CC</sub> = 0V, V <sub>IN</sub> or V <sub>O</sub> ≤ 4.5V	—	—	±1	μA	
V <sub>H</sub>	Input Hysteresis for all inputs	—	—	150	—	mV	
I <sub>CC1</sub> I <sub>CC2</sub> I <sub>CC3</sub>	Quiescent Power Supply Current	V <sub>CC</sub> = Max., V <sub>IN</sub> = GND or V <sub>CC</sub>	—	5	500	μA	

**NOTES:**

- For conditions shown as Max. or Min., use appropriate value specified under Electrical Characteristics for the applicable device type.
- Typical values are at V<sub>CC</sub> = 5V, +25°C ambient.
- Not more than one output should be shorted at one time. Duration of the test should not exceed one second.
- Duration of the condition should not exceed one second.

## POWER SUPPLY CHARACTERISTICS

Symbol	Parameter	Test Conditions <sup>(1)</sup>		Min.	Typ. <sup>(2)</sup>	Max.	Unit
$\Delta I_{CC}$	Quiescent Power Supply Current TTL Inputs HIGH	V <sub>CC</sub> = Max. V <sub>IN</sub> = 3.4V <sup>(3)</sup>		—	0.5	2	mA
I <sub>CCD</sub>	Dynamic Power Supply Current <sup>(4)</sup>	V <sub>CC</sub> = Max. Outputs Open O <sub>EA</sub> = O <sub>EB</sub> = GND 50% Duty Cycle	V <sub>IN</sub> = V <sub>CC</sub> V <sub>IN</sub> = GND	—	60	100	μA/MHz
I <sub>C</sub>	Total Power Supply Current <sup>(6)</sup>	V <sub>CC</sub> = Max. Outputs Open f <sub>o</sub> = 25MHz 50% Duty Cycle O <sub>EA</sub> = GND, O <sub>EB</sub> = V <sub>CC</sub>	V <sub>IN</sub> = V <sub>CC</sub> V <sub>IN</sub> = GND	—	7.5	13	mA
			V <sub>IN</sub> = 3.4V V <sub>IN</sub> = GND	—	7.8	14	
		V <sub>CC</sub> = Max. Outputs Open f <sub>o</sub> = 50MHz 50% Duty Cycle O <sub>EA</sub> = O <sub>EB</sub> = GND	V <sub>IN</sub> = V <sub>CC</sub> V <sub>IN</sub> = GND	—	30	50.5 <sup>(5)</sup>	
			V <sub>IN</sub> = 3.4V V <sub>IN</sub> = GND	—	30.5	52.5 <sup>(5)</sup>	

### NOTES:

- For conditions shown as Max. or Min., use appropriate value specified under Electrical Characteristics for the applicable device type.
- Typical values are at V<sub>CC</sub> = 5V, +25°C ambient.
- Per TTL driven input (V<sub>IN</sub> = 3.4V); all other inputs at V<sub>CC</sub> or GND.
- This parameter is not directly testable, but is derived for use in Total Power Supply calculations.
- Values for these conditions are examples of the I<sub>C</sub> formula. These limits are guaranteed but not tested.
- I<sub>C</sub> = I<sub>QUIESCENT</sub> + I<sub>INPUTS</sub> + I<sub>DYNAMIC</sub>  
 $I_C = I_{CC} + \Delta I_{CC} D_H N_T + I_{CCD} (f_o N_o)$   
 I<sub>CC</sub> = Quiescent Current (I<sub>CC1</sub>, I<sub>CC2</sub> and I<sub>CC3</sub>)  
 $\Delta I_{CC}$  = Power Supply Current for a TTL High Input (V<sub>IN</sub> = 3.4V)  
 D<sub>H</sub> = Duty Cycle for TTL Inputs High  
 N<sub>T</sub> = Number of TTL Inputs at D<sub>H</sub>  
 I<sub>CCD</sub> = Dynamic Current Caused by an Input Transition Pair (HLH or LHL)  
 f<sub>o</sub> = Output Frequency  
 N<sub>o</sub> = Number of Outputs at f<sub>o</sub>  
 All currents are in milliamps and all frequencies are in megahertz.

SWITCHING CHARACTERISTICS OVER OPERATING RANGE<sup>(3,4)</sup>

Symbol	Parameter	Conditions <sup>(1)</sup>	FCT810BT		FCT810CT		Unit
			Min. <sup>(2)</sup>	Max.	Min. <sup>(2)</sup>	Max.	
t <sub>PLH</sub>	Propagation Delay	C <sub>L</sub> = 50pF R <sub>L</sub> = 500Ω	1.5	4.5	1.5	4.3	ns
t <sub>PHL</sub>	I <sub>NA</sub> to O <sub>Ax</sub> , I <sub>NA</sub> to O <sub>Bx</sub>						
t <sub>R</sub>	Output Rise Time		—	1.5	—	1.5	ns
t <sub>F</sub>	Output Fall Time		—	1.5	—	1.5	ns
t <sub>SK1(O)</sub>	Output skew (same bank): skew between outputs of same bank and same package (same transition)		—	0.5	—	0.3	ns
t <sub>SK2(O)</sub>	Output skew (all banks): skew between outputs of all banks of same package (inputs tied together)		—	0.7	—	0.6	ns
t <sub>SK(P)</sub>	Pulse skew: skew between opposite transitions of same output ( t <sub>PHL</sub> - t <sub>PLH</sub>  )		—	0.7	—	0.7	ns
t <sub>SK(T)</sub>	Package skew: skew between outputs of different packages at same power supply voltage, temperature, package type and speed grade		—	1.2	—	1	ns
t <sub>PZL</sub>	Output Enable Time		1.5	6	1.5	5	ns
t <sub>PZH</sub>	O <sub>EA</sub> to O <sub>Ax</sub> , O <sub>EB</sub> to O <sub>Bx</sub>						
t <sub>PLZ</sub>	Output Disable Time	1.5	6	1.5	5	ns	
t <sub>PHZ</sub>	O <sub>EA</sub> to O <sub>Ax</sub> , O <sub>EB</sub> to O <sub>Bx</sub>						

NOTES:

1. See test circuits and waveforms.
2. Minimum limits are guaranteed but not tested on Propagation Delays.
3. t<sub>PLH</sub>, t<sub>PHL</sub>, t<sub>SK(t)</sub> are production tested. All other parameters guaranteed but not production tested.
4. Propagation delay range indicated by Min. and Max. limit is due to V<sub>CC</sub>, operating temperature and process parameters. These propagation delay limits do not imply skew.

TEST CIRCUITS AND WAVEFORMS

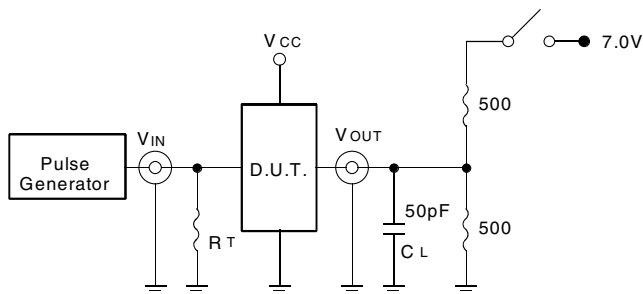

Test Circuit for All Outputs

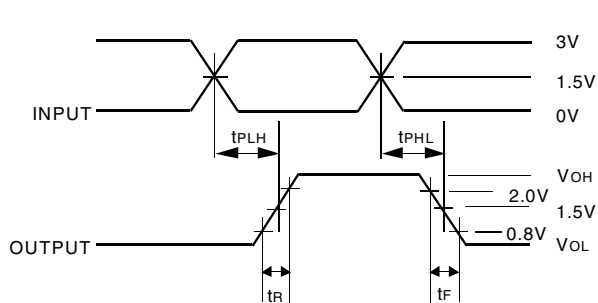

Package Delay

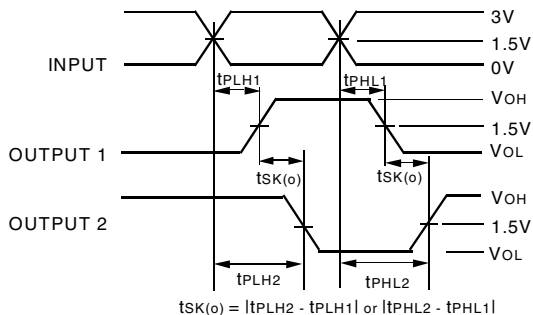

Output Skew (All Banks) -  $tsk2(o)$

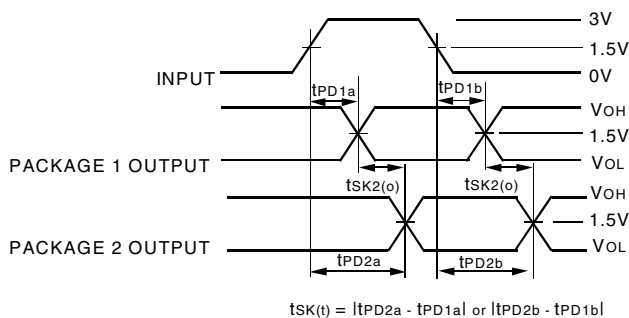

Package Skew -  $tsk(t)$

SWITCH POSITION

Test	Switch
Disable LOW Enable LOW	Closed
Disable HIGH Enable HIGH	GND

DEFINITIONS:

CL = Load capacitance: includes jig and probe capacitance.  
RT = Termination resistance: should be equal to ZOUT of the Pulse Generator.

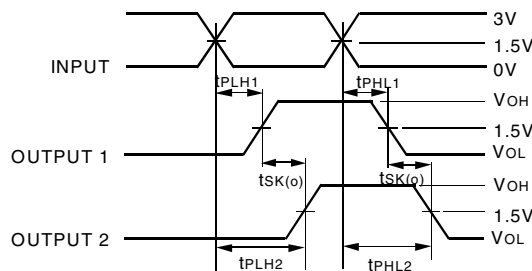

$$tsk(o) = |tPLH2 - tPLH1| \text{ or } |tPHL2 - tPHL1|$$

Output Skew (Same Bank) -  $tsk1(o)$

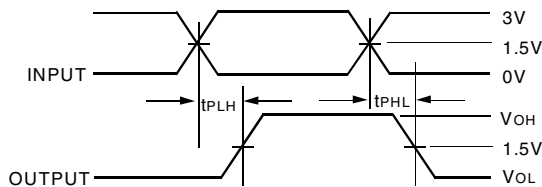

$$tsk(p) = |tPHL - tPLH|$$

Pulse Skew -  $tsk(p)$

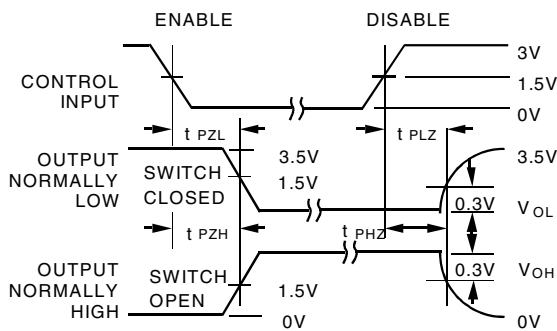

Enable and Disable Times

NOTES:

- Diagram shown for input Control Enable-LOW and input Control Disable-HIGH
- Pulse Generator for All Pulses: Rate  $\leq 1.0\text{MHz}$ ;  $t_r \leq 2.5\text{ns}$ ;  $t_f \leq 2.5\text{ns}$

NOTE:

- Package 1 and Package 2 are same device type and speed grade.

### ORDERING INFORMATION

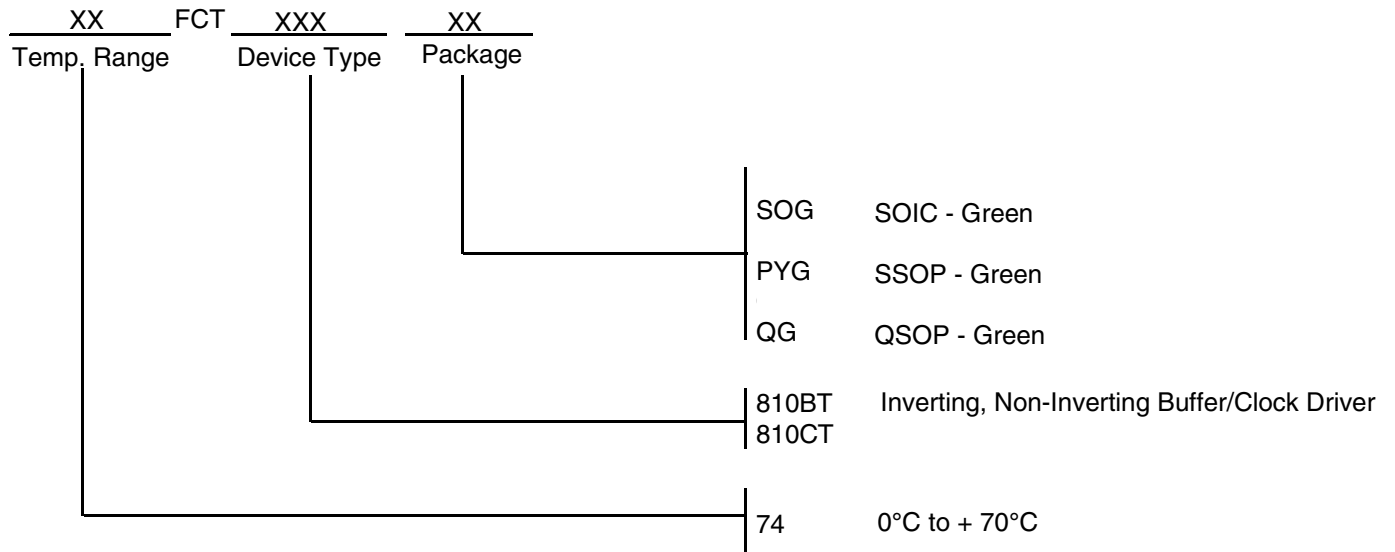

**CORPORATE HEADQUARTERS**  
6024 Silver Creek Valley Road  
San Jose, CA 95138

**for SALES:**  
800-345-7015 or 408-284-8200  
fax: 408-284-2775  
www.idt.com

**for Tech Support:**  
clockhelp@idt.com

## Looking for pricing, stock, or lifecycle information?

Click below to explore more details on WIN SOURCE:

- ⊖ [View IDT74FCT810CTSO on WIN SOURCE](#)
- ⊖ [IDT, Integrated Device Technology Inc Information](#)

## Optimize Your Supply Chain with WIN SOURCE Solutions

- ✓ Global Sourcing Solution
- ✓ Obsolete Management
- ✓ Cost Control Management
- ✓ Shortage Management
- ✓ Alternative Solution
- ✓ Excess Inventory Management