

Prepared	<i>Guo</i>	Product Specifications AN17808B	Ref No.	A-1
Checked	<i>Kenneth Law</i>		Total Page	14
Approved	<i>Ziguli</i>		Page No.	1

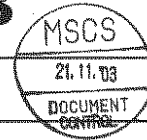

Structure	Silicon Monolithic Bipolar IC
Appearance	SIL-12 Pins Plastic Package (Power-type with Fin)
Application	Low Frequency Amplifier
Function	Dual 5W Audio Power Amplifier, with muting circuit and incorporating protection circuits

A Absolute Maximum Ratings					
No.	Item	Symbol	Ratings	Unit	Note
1	Storage Temperature	Tstg	-55 ~ +150	°C	1
2	Operating Ambient Temperature	Topr	-25 ~ +75	°C	1
3	Operating Ambient Pressure	Popr	$1.013 \times 10^5 \pm 0.61 \times 10^5$	Pa	
4	Operating Constant Acceleration	Gopr	9,810	m/s ²	
5	Operating Shock	Sopr	4,900	m/s ²	
6	Supply Voltage	Vcc	26.0	V	
7	Supply Current	Icc	4.0	A	
8	Power Dissipation	P _D	37.5	W	2

Operating Supply Voltage	Vcc	10.0 V ~ 24.0V
--------------------------	-----	----------------

Note 1) The temperature of all item shall be Ta = 25°C except storage temperature and operating ambient temperature.

2) Ta = 75°C



Eff. Date	Eff. Date	Eff. Date	Eff. Date
22-OCT-03	21-NOV-03		

Prepared	<i>Cao</i>	Product Specifications AN17808B	Ref No.	A-2
Checked	<i>Kenneth Law</i>		Total Page	14
Approved	<i>H. Gulin</i>		Page No.	2



A Absolute Maximum Ratings					
No.	Item	Symbol	Ratings	Unit	Note
1	Pin Voltage (2-Pin)	V2	-0.3 ~ +3.0	V	1
2	Pin Voltage (5-Pin)	V5	-0.3 ~ +3.0	V	1

Note: 1) Do not apply a current or voltage from the external to the terminals not described above. For circuit current, '+' denotes the current flowing into IC and, '-' denotes the current flowing out of IC.

Eff. Date	Eff. Date	Eff. Date	Eff. Date	
22-OCT-03	21-NOV-03			

Prepared	<i>Guo</i>	Product Specifications AN17808B	Ref No.	B-1
Checked	<i>Kenneth Law</i>		Total Page	14
Approved	<i>Higuchi</i>		Page No.	3



B Electrical Characteristics (Ta = 25°C ± 2°C, unless otherwise specified, Vcc=19V, RL=8Ω and f=1kHz)									
No.	Item	Symbol	Test Circuit	Condition	Limit			Unit	Note
					Min	Typ	Max		
1	Quiescent Current	IcQ	1	Vin=0mV	-	35	70	mA	
2	Output End Noise Voltage	Vno	1	No Input Rg=10kΩ	-	0.22	0.4	mV	1
3	Voltage Gain	Gv	1	Vin=57mV	32	34	36	dB	
4	Total Harmonic Distortion	THD	1	Vin=57mV	-	0.2	0.4	%	
5	Maximum Output Power 1	Po1	1	Vcc=19V THD=10%	4.0	5.0	-	W	
6	Maximum Output Power 2	Po2	1	Vcc=22V THD=10%	5.6	7.0	-	W	
7	Ripple Rejection Ratio	RR	1	Vr=1Vrms, fr=120Hz, Rg=10kΩ	45	55	-	dB	1
8	Channel Balance	CB	1	Vin=57mV	-1.0	0	1.0	dB	
9	Muting Ratio	MR	1	Vin=57mV Vmute ≥ 3.0V	65	75	-	dB	
10	Muting Control Voltage	Vmute	1	Vin = 57mV, MR ≥ 65dB	3.0	-	-	V	
11	Standby On Voltage	Vstb-on	1	No Input Icc < 0.1mA	-	-	0.4	V	
12	Standby Off Voltage	Vstb-off	1	No Input Icc ≥ 17mA	3.0	-	-	V	
13	Channel Crosstalk	CT	1	Vin = 57mV Rg=10kΩ	50	60	-	dB	

Note 1) For this measurement, use the 20Hz~20kHz (12dB/OCT) filter.

Eff. Date	Eff. Date	Eff. Date	Eff. Date	
22-OCT-03	21-NOV-03			

Prepared	<i>[Signature]</i>	Product Specifications AN17808B	Ref No.	C-1
Checked	<i>Kenneth Law</i>		Total Page	14
Approved	<i>Higuli</i>		Page No.	4



(Description of Test Circuit and Test Method)
Test Circuit 1

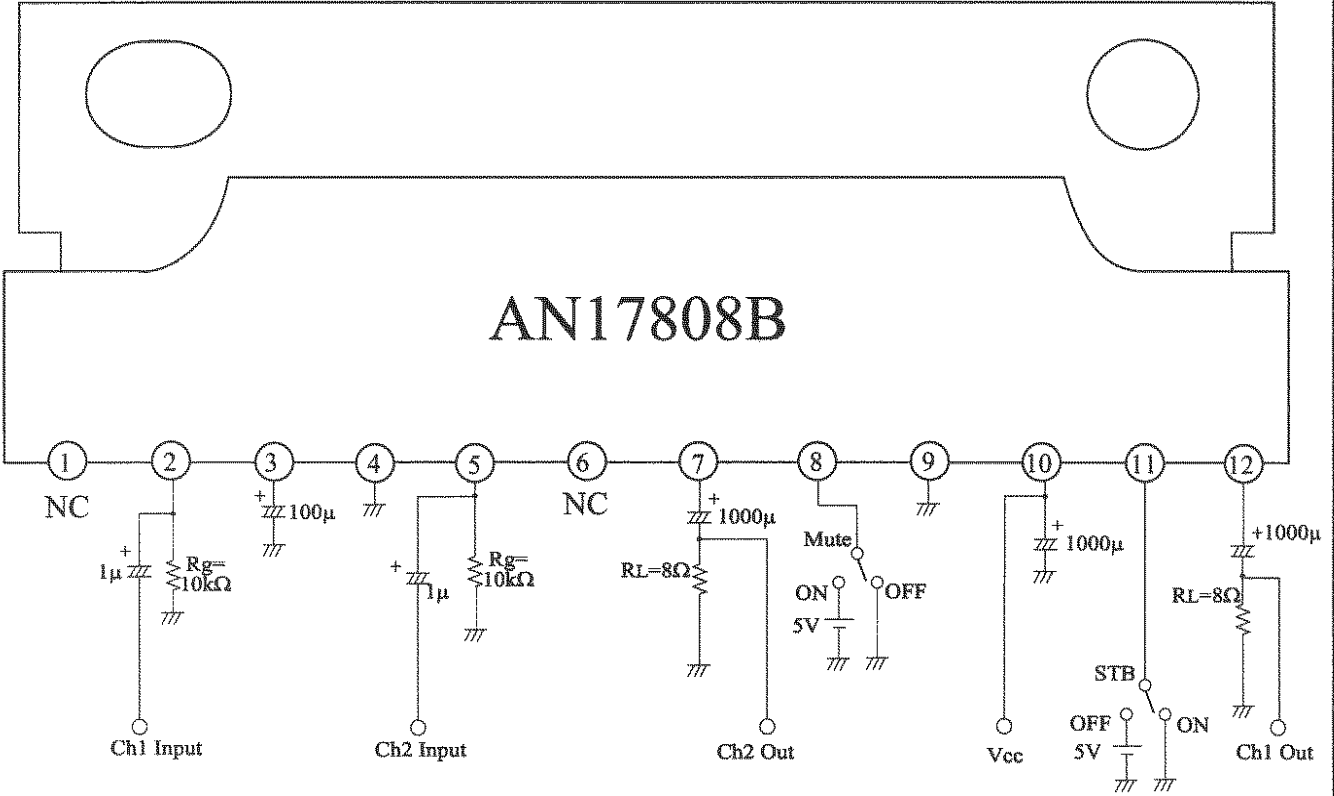

Note : For STB 'OFF', connect to 5V.
Mute 'OFF' means 0V.

Eff. Date	Eff. Date	Eff. Date	Eff. Date
22-OCT-03	21-NOV-03		

Prepared	<i>Guo</i>	Product Specifications AN17808B	Ref No.	D-1
Checked	<i>Kenneth Law</i>		Total Page	14
Approved	<i>Higalin</i>		Page No.	5



Circuit Function Block Diagram

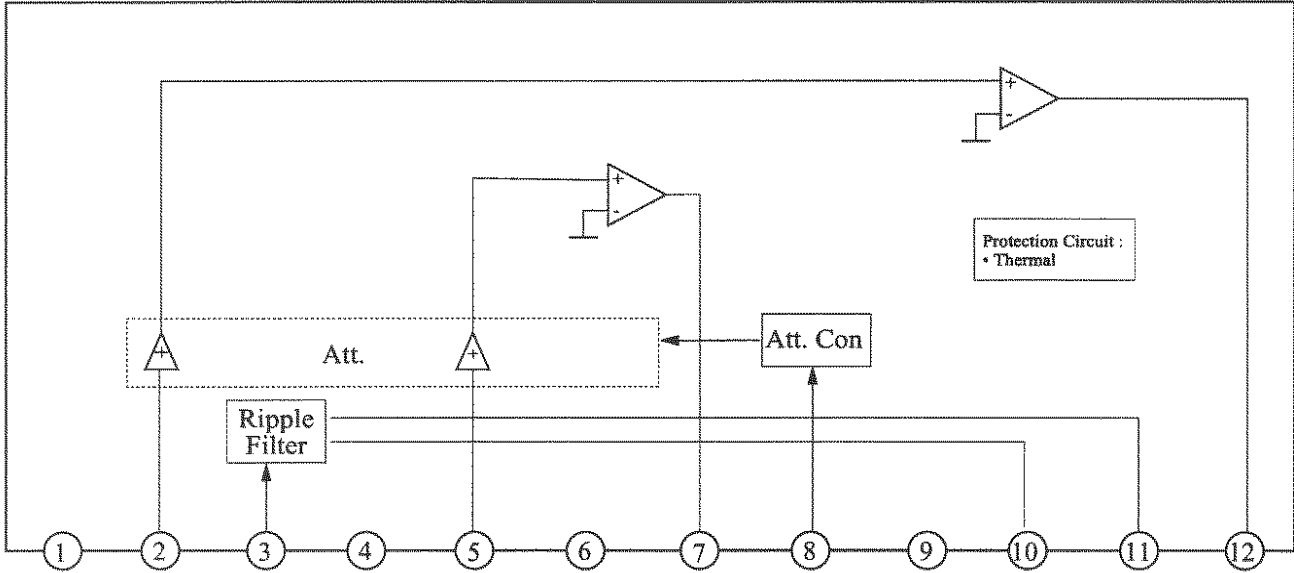

Pin Descriptions

Pin No.	Pin Name	Pin No.	Pin Name
1	N.C	7	Channel 2 Output
2	Channel 1 Input	8	Mute
3	Ripple Filter	9	Output GND
4	Input GND	10	Vcc
5	Channel 2 Input	11	Standby
6	N.C	12	Channel 1 Output

Eff. Date	Eff. Date	Eff. Date	Eff. Date
22-OCT-03	21-NOV-03		

Prepared	Lim Fuey Sheen	Product Specifications AN17808B	Ref No.	E
Checked	Kenneth Law		Total Page	14
Approved	Yasuo Higuchi		Page No.	6

12-SIL(FP)

Package Name

FP-12S

Unit : mm

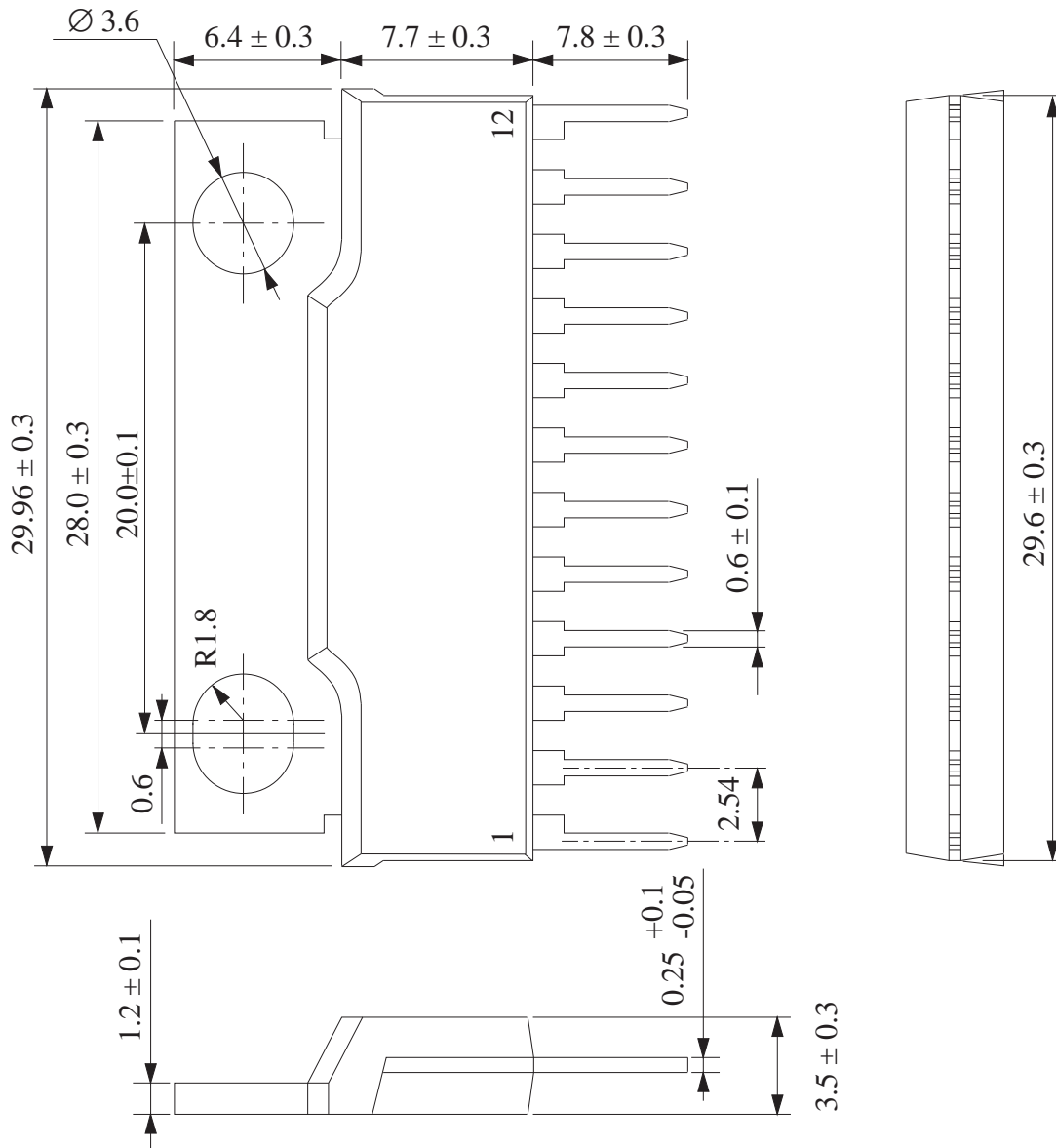

*4

Eff. Date	Eff. Date	Eff. Date	Eff. Date
28-MAR-05			

Prepared	Lim Fuey Sheen	Product Specifications (Leadfree) AN17808B	Ref No.	F
Checked	Kenneth Law		Total Page	14
Approved	Yasuo Higuchi		Page No.	7A

(Structure Description)

Chip surface passivation	SiN, PSG, Others ()	①
Lead frame material	Fe group, Cu group, Others ()	②, ⑥
Inner lead surface process	Ag plating, Au plating, Others ()	②
Outer lead surface process	Solder plating (98Sn-2Bi), Solder dip, Others ()	⑥
Chip mounting method	Ag paste, Au-Si alloy, Solder (95.5Pb-2.5Ag-2Sn)**	③
Wire bonding method	Thermalsonic bonding, Others ()	④
Wire material	Au, Others ()	④
Mold material	Epoxy, Others ()	⑤
Molding method	Transfer mold, Multiplunger mold, Others ()	⑤
Fin material	Cu group, Others ()	⑦

*3

*3

Package FP-12S

**Under RoHS exemption clause, Lead (Pb) in high melting temperature type solder (i.e. tin-lead solder alloys containing more than 85% of lead), is exempted until 2010.

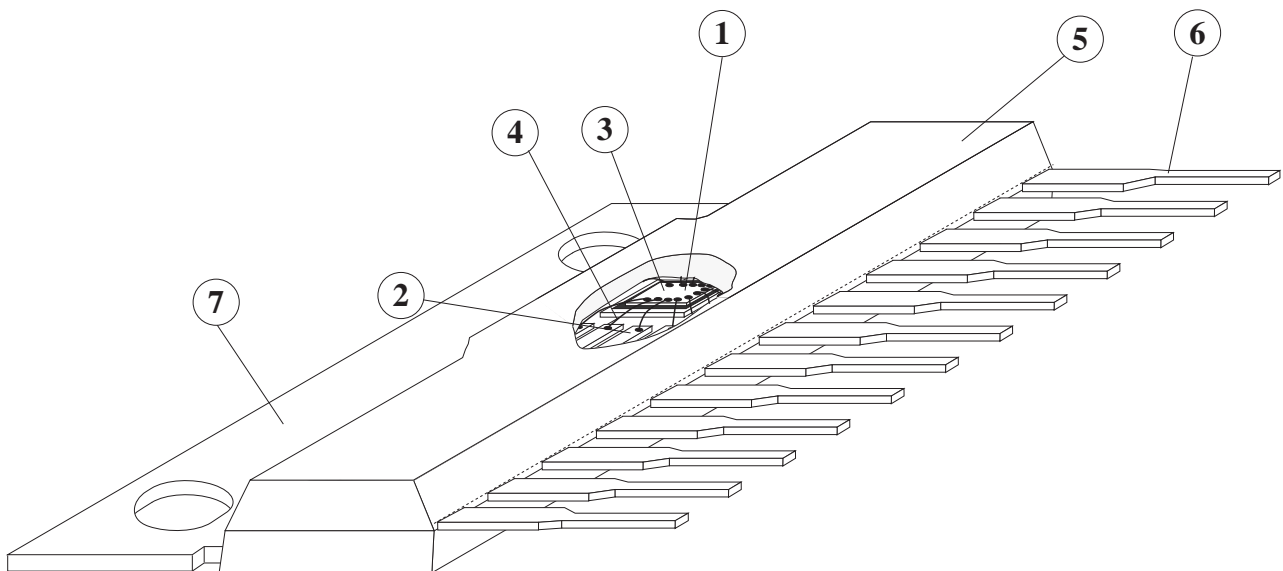

*3

Eff. Date	Eff. Date	Eff. Date	Eff. Date
-	-	4-NOV-04	15-DEC-04

Prepared	<i>Law</i>
Checked	<i>Kenneth Law</i>
Approved	<i>Higuchi</i>

Product Specifications

(Technical Data)

AN17808B

Ref No.	G-1
Total Page	14
Page No.	8



Application Circuit 1

Standby Pin is controlled by microcontroller.

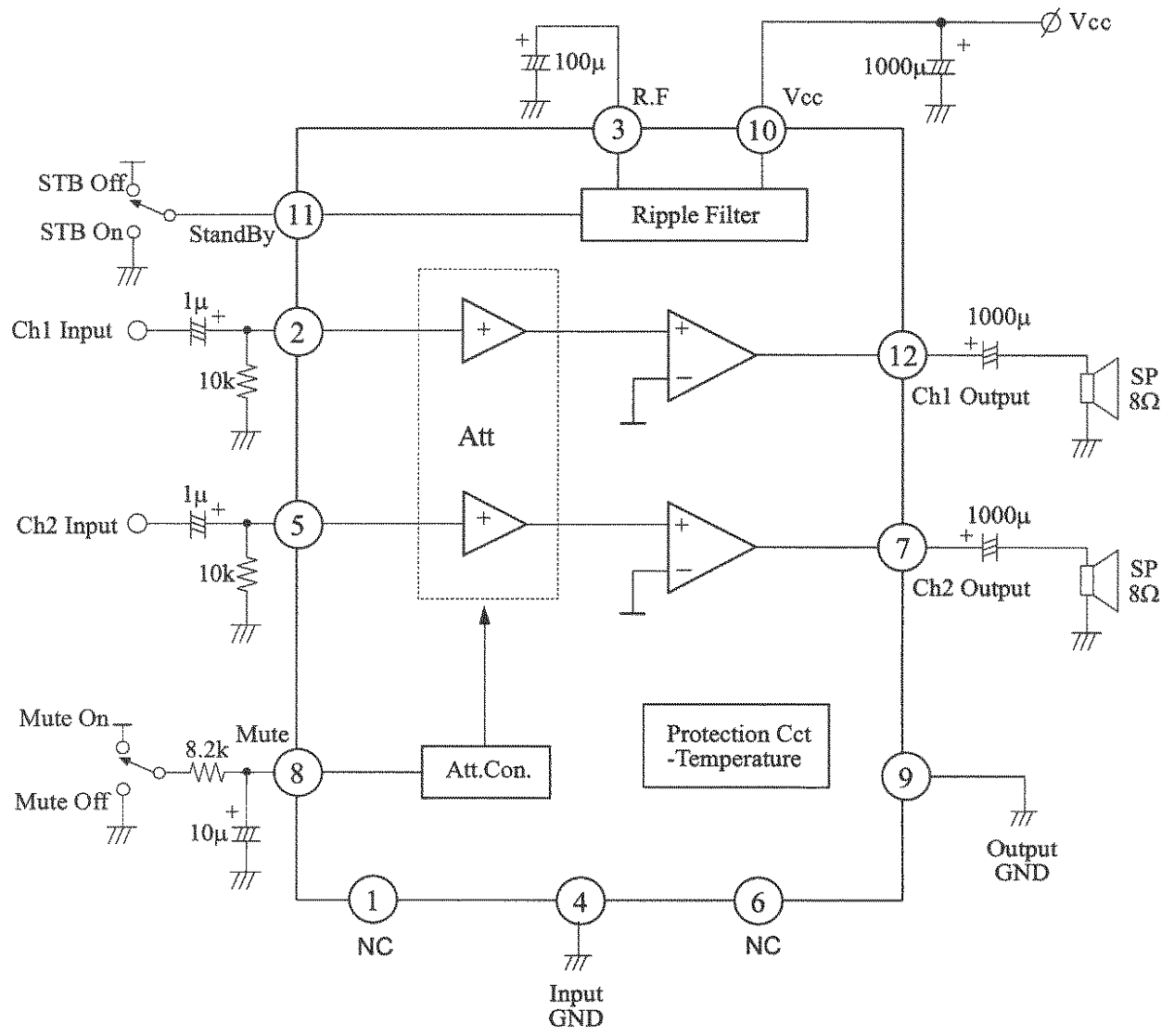

STB 'OFF'	5V
STB 'ON'	0V
Mute 'OFF'	0V
Mute 'ON'	5V

Eff. Date	Eff. Date	Eff. Date	Eff. Date
22-OCT-03	21-NOV-03		

Prepared	<i>[Signature]</i>
Checked	<i>Kenneth Law</i>
Approved	<i>H. J. J. J.</i>

Product Specifications

(Technical Data)

AN17808B

Ref No.	G-1
Total Page	14
Page No.	9



Application Circuit 2

Standby Pin is controlled by Vcc.

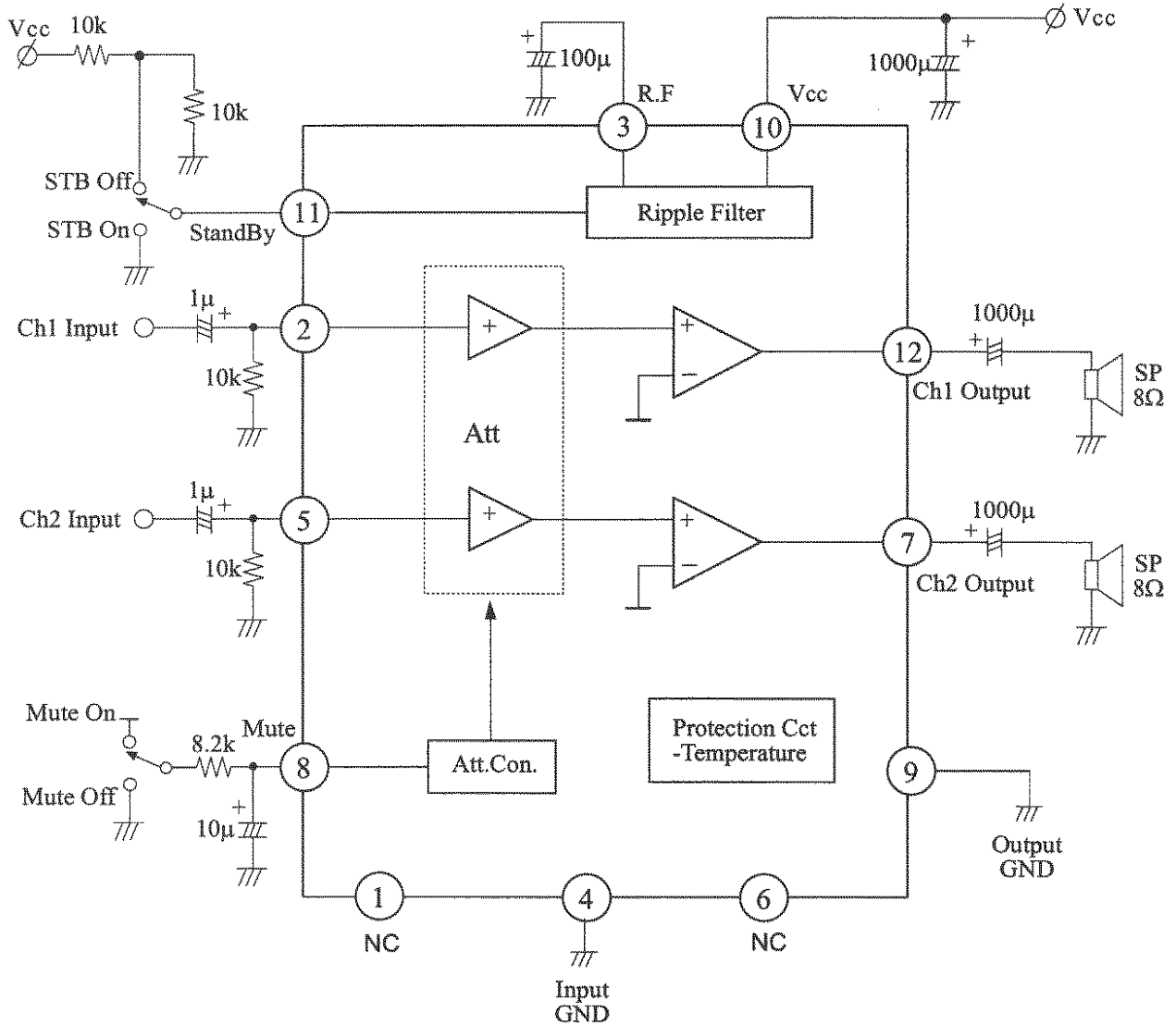

Mute 'OFF'	0V
Mute 'ON'	5V

Eff. Date	Eff. Date	Eff. Date	Eff. Date
22-OCT-03	21-NOV-03		

Prepared *[Signature]*
 Checked *Kenneth Law*
 Approved *Higali*

Product Specifications
 (Technical Data)
AN17808B

Ref No. G-2
 Total Page 14
 Page No. 10



Pin No.	Function	Adjacent Circuitry	Description	DC Bias (V)
2, 5	Ch1, Ch2 Input		This is the amplifier input pin.	0V
3	Ripple Filter		This is the pin to connect the positive terminal of a ripple filter capacitor.	Vcc-1.5VBE
4	Input GND		Input ground pin.	0V
1,6	Not Connected			

Eff. Date	Eff. Date	Eff. Date	Eff. Date
22-OCT-03	21-NOV-03		

Prepared	<i>bio</i>	Product Specifications (Technical Data) AN17808B	Ref No.	G-2
Checked	<i>Kenneth Law</i>		Total Page	14
Approved	<i>Higali</i>		Page No.	11



Pin No.	Function	Adjacent Circuitry	Description	DC Bias (V)
12, 7	Ch1 and Ch2 Output		Ch1 and Ch2 output pin	Vcc/2
8	Mute		Mute input pin. Mute 'On' = 5V Mute 'Off' = 0V	
9	Output GND		Ch1 and Ch2 output ground.	0V
10	Vcc		This is the power supply pin.	Typ: 19V

Eff. Date	Eff. Date	Eff. Date	Eff. Date
22-OCT-03	21-NOV-03		

Prepared	<i>Guo</i>
Checked	<i>Kenneth Law</i>
Approved	<i>H. Galin</i>

Product Specifications
(Technical Data)
AN1780&B

Ref No.	G-2
Total Page	14
Page No.	12



Pin No.	Function	Adjacent Circuitry	Description	DC Bias (V)
11	Standby		This is the Standby control pin.	

Eff. Date	Eff. Date	Eff. Date	Eff. Date
22-OCT-03	21-NOV-03		

Prepared	<i>[Signature]</i>	Product Specifications (Technical Data) AN17808B	Ref No.	G-3
Checked	<i>Kenneth Law</i>		Total Page	14
Approved	<i>Zigalin</i>		Page No.	13



PD - Ta Curves

- (1) $T_c = T_a$, 62.5W ($\theta_{j-c} = 2 \text{ }^\circ\text{C/W}$)
- (2) 20.83W ($\theta_f = 4.0 \text{ }^\circ\text{C/W}$)
 With a 100cm² X 3mm Al heat sink (black colour coated)
 or a 200cm² X 2mm Al heat sink (not lacquered)
- (3) 15.63W ($\theta_f = 6.0 \text{ }^\circ\text{C/W}$)
 With a 100cm² X 2mm Al heat sink (not lacquered)
- (4) 3.0W at $T_a = 25^\circ\text{C}$ ($\theta_{j-a} = 42 \text{ }^\circ\text{C/W}$)
 Without heat sink

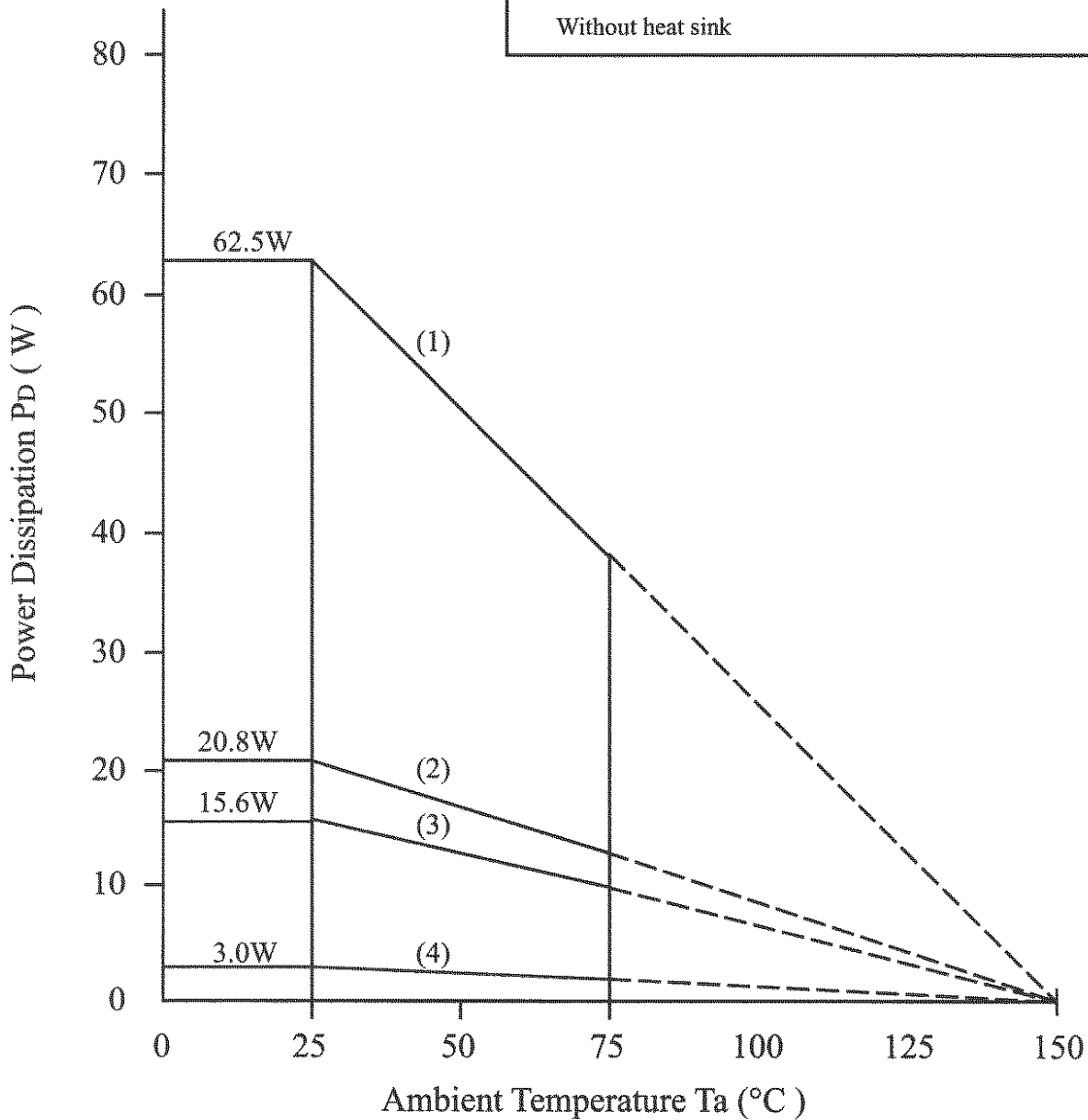

Eff. Date	Eff. Date	Eff. Date	Eff. Date
22-OCT-03	21-NOV-03		

Prepared	<i>Law</i>	Product Specifications AN17808B	Ref No.	H
Checked	<i>Kenneth Law</i>		Total Page	14
Approved	<i>Higuchi</i>		Page No.	14





Application's Precautions

- (1) External heatsink is needed when used. External heatsink should be fixed to the chassis.
- (2) Fin of the IC can be connected to GND.
- (3) Please prevent "Output to Vcc short", "Output to GND short", "Pin shift" and "Load short". The IC may be damaged if any of these occurs and smoke may be observed.
- (4) The temperature protection circuit will operate at Tj around 150°C. However, if temperature decrease, the protection circuit will automatically be deactivated and resume normal operation.
- (5) The Absolute Maximum Supply Voltage for this IC is specified as 26V. The IC is permitted to operate up to this voltage, without causing damage, for the condition that no signal is applied to all the 2 input pins.
- (6) For the condition of chip junction temperature below the minimum thermal shutdown temperature, under continuous operation, this will not cause damage to the IC for the recommended application. The minimum thermal shutdown temperature of this IC is typically 140 °C. This value is provided as a design reference and is not guaranteed by testing.

Eff. Date	Eff. Date	Eff. Date	Eff. Date
22-OCT-03	21-NOV-03		

Looking for pricing, stock, or lifecycle information?

Click below to explore more details on WIN SOURCE:

-  [View AN17808B on WIN SOURCE](#)
-  [Panasonic Information](#)

Optimize Your Supply Chain with WIN SOURCE Solutions

-  Global Sourcing Solution
-  Obsolete Management
-  Cost Control Management
-  Shortage Management
-  Alternative Solution
-  Excess Inventory Management