



# THE DATASHEET OF TUSB1106IPWRQ1



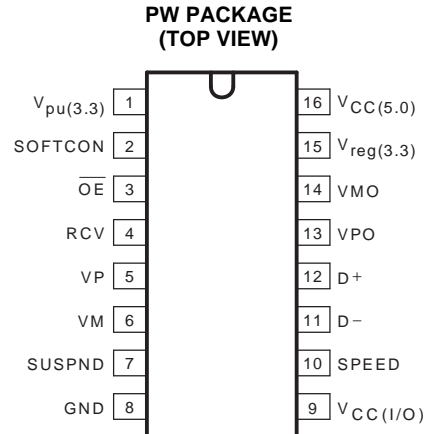
## ADVANCED UNIVERSAL SERIAL BUS TRANSCEIVERS

Check for Samples: [TUSB1106-Q1](#)

### FEATURES

- Qualified for Automotive Applications
- Compatible With Universal Serial Bus Specification Rev. 2.0
- Transmit and Receive Serial Data at Both Full-Speed (12-Mbit/s) and Low-Speed (1.5-Mbit/s) Data Rates
- Integrated Bypassable 5-V to 3.3-V Voltage Regulator for Powering Via USB  $V_{BUS}$
- $V_{BUS}$  Disconnection Indication Through  $V_P$  and  $V_M$
- Used as USB Device Transceiver or USB Host Transceiver
- Stable RCV Output During SE0 Condition
- Two Single-Ended Receivers With Hysteresis
- Low-Power Operation, Ideal for Portable Equipment
- Support I/O Voltage Range From 1.65 V to 3.6 V

- Available in a Thin Shrink Small-Outline Package [TSSOP (PW)]



### DESCRIPTION

The TUSB1106-Q1 universal serial bus (USB) transceiver is compliant with the Universal Serial Bus Specification Rev. 2.0. This device can transmit and receive serial data at both full-speed (12-Mbit/s) and low-speed (1.5-Mbit/s) data rates. The TUSB1106-Q1 can be used as USB device transceiver or USB host transceiver.

The device allows USB application-specific ICs (ASICs) and programmable logic devices (PLDs), with power-supply voltages from 1.65 V to 3.6 V, to interface with the physical layer (PHY) of the universal serial bus. It has an integrated 5-V to 3.3-V voltage regulator for direct powering via the USB supply  $V_{BUS}$ .

The TUSB1106-Q1 allows only differential input mode and is available in a PW package.

The TUSB1106-Q1 is ideal for portable electronic devices such as mobile phones, personal digital assistants, information appliances, and digital still cameras.

### ORDERING INFORMATION

$T_A$	PACKAGE <sup>(1)</sup> <sup>(2)</sup>	ORDERABLE PART NUMBER	TOP-SIDE MARKING
–40°C to 85°C	TSSOP – PW      Reel of 2000	TUSB1106IPWRQ1	TU1106I

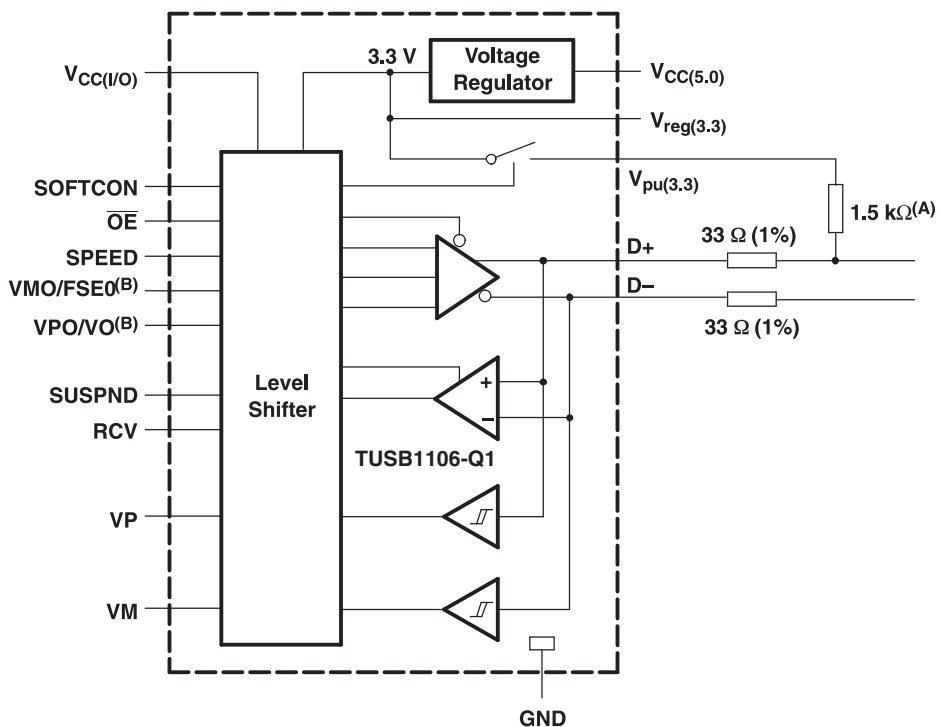
(1) Package drawings, thermal data, and symbolization are available at [www.ti.com/packaging](http://www.ti.com/packaging).

(2) For the most current package and ordering information, see the Package Option Addendum at the end of this document, or see the TI website at [www.ti.com](http://www.ti.com).



Please be aware that an important notice concerning availability, standard warranty, and use in critical applications of Texas Instruments semiconductor products and disclaimers thereto appears at the end of this data sheet.

FUNCTIONAL BLOCK DIAGRAM



- A. Connect to D- for low-speed operation and to D+ for high-speed operation.
- B. Pin function depends on device type.

**TERMINAL FUNCTIONS**

TERMINAL		I/O	DESCRIPTION
NAME	NO.		
$\overline{\text{OE}}$	3	I	Output enable (CMOS level with respect to $V_{\text{CC(I/O)}}$ , active LOW). Enables the transceiver to transmit data on the USB bus input pad. Push pull, CMOS.
RCV	4	O	Differential data receiver (CMOS level with respect to $V_{\text{CC(I/O)}}$ ). Driven LOW when input SUSPND is HIGH. The output state of RCV is preserved and stable during an SE0 condition output pad. Push pull, 4-mA output drive, CMOS.
VP	5	O	Single-ended D+ receiver (CMOS level with respect to V). For external detection of single-ended zero (SE0), error conditions, speed of connected device. Driven HIGH when no supply voltage is connected to $V_{\text{CC(5.0)}}$ and $V_{\text{reg(3.3)}}$ output pad. Push pull, 4-mA output drive, CMOS.
VM	6	O	Single-ended D– receiver (CMOS level with respect to $V_{\text{CC(I/O)}}$ ). For external detection of single-ended zero (SE0), error conditions, speed of connected device. Driven HIGH when no supply voltage is connected to $V_{\text{CC(5.0)}}$ and $V_{\text{reg(3.3)}}$ output pad. Push pull, 4-mA output drive, CMOS.
SUSPND	7	I	Suspend (CMOS level with respect to $V_{\text{CC(I/O)}}$ ). A HIGH level enables low-power state while the USB bus is inactive and drives output RCV to a LOW-level input pad. Push pull, CMOS.
MODE		I	Mode (CMOS level with respect to $V_{\text{CC(I/O)}}$ ). A HIGH level enables the differential input mode (VPO, VMO), whereas a LOW level enables a single-ended input mode (VO, FSE0). See Table 5 and Table 6 input pad. Push pull, CMOS.
GND	8		Ground supply
$V_{\text{CC(I/O)}}$	9		Supply voltage for digital I/O pins (1.65 to 3.6 V). When $V_{\text{CC(I/O)}}$ is not connected, the D+ and D– pins are in 3-state. This supply pin is independent of $V_{\text{CC(5.0)}}$ and $V_{\text{reg(3.3)}}$ and must never exceed the $V_{\text{reg(3.3)}}$ voltage.
SPEED	10	I	Speed selection (CMOS level with respect to $V_{\text{CC(I/O)}}$ ). Adjusts the slew rate of differential data outputs D+ and D– according to the transmission speed. Input pad, push pull, CMOS. LOW – low speed (1.5 Mbit/s) HIGH – full speed (12 Mbit/s)
D–	11	AI/O	Negative USB data bus connection (analog, differential). For low-speed mode, connect to pin $V_{\text{pu(3.3)}}$ via a 1.5-k $\Omega$ resistor.
D+	12	AI/O	Positive USB data bus connection (analog, differential). For full-speed mode, connect to pin $V_{\text{pu(3.3)}}$ via a 1.5-k $\Omega$ resistor.
VPO/VO		I	Driver data (CMOS level with respect to $V_{\text{CC(I/O)}}$ , Schmitt trigger). See <a href="#">Driving Function table</a> . Push pull, CMOS.
VPO	13		
VMO/FSE0		I	Driver data (CMOS level with respect to $V_{\text{CC(I/O)}}$ , Schmitt trigger). See <a href="#">Driving Function table</a> . Push pull, CMOS.
VMO	14		
$V_{\text{reg(3.3)}}$	15		Internal regulator option. Regulated supply-voltage output (3 V to 3.6 V) during 5-V operation. A decoupling capacitor of at least 0.1 mF is required for the regulator bypass option. Used as a supply-voltage input for 3.3 V $\pm$ 10% operation.
$V_{\text{CC(5.0)}}$	16		Internal regulator option. Supply-voltage input (4 V to 5.5 V). Can be connected directly to USB supply VBUS regulator bypass option. Connect to $V_{\text{reg(3.3)}}$ .
$V_{\text{pu(3.3)}}$	1		Pullup supply voltage (3.3 V $\pm$ 10%). Connect an external 1.5-k $\Omega$ resistor on D+ (full speed) or D– (low speed). Pin function is controlled by input SOFTCON. SOFTCON = LOW – $V_{\text{pu(3.3)}}$ floating (high impedance), ensures zero pullup current SOFTCON = HIGH – $V_{\text{pu(3.3)}} = 3.3$ V, internally connected to $V_{\text{reg(3.3)}}$
SOFTCON	2	I	Software-controlled USB connection. A HIGH level applies 3.3 V to pin $V_{\text{pu(3.3)}}$ , which is connected to an external 1.5-k $\Omega$ pullup resistor. This allows USB connect/disconnect signaling to be controlled by software input pad. Push pull, CMOS.

## FUNCTIONAL DESCRIPTION

### Function Selection

**FUNCTION TABLE**

SUSPND	$\overline{OE}$	D+, D–	RCV	VP, VM	FUNCTION
L	L	Driving and receiving	Active	Active	Normal driving (differential receiver active)
L	H	Receiving <sup>(1)</sup>	Active	Active	Receiving
H	L	Driving	Inactive <sup>(2)</sup>	Active	Driving during suspend <sup>(3)</sup> (differential receiver inactive)
H	H	High-Z <sup>(1)</sup>	Inactive <sup>(2)</sup>	Active	Low-power state

- (1) Signal levels on D+ and D– are determined by other USB devices and external pullup/pulldown resistors.  
 (2) In suspend mode (SUSPND = HIGH) the differential receiver is inactive and output RCV is always LOW. Out of suspend (K), signaling is detected via the single-ended receivers VP and VM.  
 (3) During suspend, the slew-rate control circuit of low-speed operation is disabled. The D+ and D– lines are still driven to their intended states, without slew-rate control. This is permitted because driving during suspend is used to signal remote wakeup by driving a K signal (one transition from idle to K state) for a period of 1 ms to 15 ms.

### Operating Functions

**Driving Function (Pin  $\overline{OE}$  = L)  
Using Differential Input Data Interface**

VMO	VPO	DATA	DATA STATE	
			LOW SPEED	FULL SPEED
L	L	SE0	X	X
H	L	Differential logic 0	J	K
L	H	Differential logic 1	K	J
H	H	Illegal state	X	X

**Table 1. Receiving Function (Pin  $\overline{OE}$  = H)**

D+, D–	RCV	VP <sup>(1)</sup>	VM <sup>(1)</sup>	DATA STATE	
				LOW SPEED	FULL SPEED
Differential logic 0	L	L	H	J	K
Differential logic 1	H	H	L	K	J
SE0	RCV* <sup>(2)</sup>	L	L	X	X

- (1) VP = VM = H indicates the sharing mode ( $V_{CC(5.0)}$  and  $V_{reg(3.3)}$  are disconnected).  
 (2) RCV\* denotes the signal level on output RCV just before SE0 state occurs. This level is stable during the SE0 period.

### Power-Supply Configurations

The TUSB1106-Q1 can be used with different power-supply configurations, which can be dynamically changed. An overview is given in [Table 3](#).

- Normal mode – Both  $V_{CC(I/O)}$  and  $V_{CC(5.0)}$  or ( $V_{CC(5.0)}$  and  $V_{reg(3.3)}$ ) are connected. For 5-V operation,  $V_{CC(5.0)}$  is connected to a 5-V source (4 V to 5.5 V). The internal voltage regulator then produces 3.3 V for the USB connections. For 3.3-V operation, both  $V_{CC(5.0)}$  and  $V_{reg(3.3)}$  are connected to a 3.3-V source (3 V to 3.6 V).  $V_{CC(I/O)}$  is independently connected to a voltage source (1.65 V to 3.6 V), depending on the supply voltage of the external circuit.
- Disable mode –  $V_{CC(I/O)}$  is not connected,  $V_{CC(5.0)}$  or ( $V_{CC(5.0)}$  and  $V_{reg(3.3)}$ ) are connected. In this mode, the internal circuits of the TUSB1106-Q1 ensure that the D+ and D– pins are in 3-state and the power consumption drops to the low-power (suspended) state level. Some hysteresis is built into the detection of  $V_{CC(I/O)}$  lost.
- Sharing mode –  $V_{CC(I/O)}$  is connected, ( $V_{CC(5.0)}$  and  $V_{reg(3.3)}$ ) are not connected. In this mode, the D+ and D– pins are made 3-state and the TUSB1106-Q1 allows external signals of up to 3.6 V to share the D+ and D–

lines. The internal circuits of the TUSB1106-Q1 ensure that virtually no current (maximum 10  $\mu$ A) is drawn via the D+ and D– lines. The power consumption through  $V_{CC(I/O)}$  drops to the low-power (suspended) state level. Both the VP and VM pins are driven HIGH to indicate this mode. Pin RCV is made LOW. Some hysteresis is built into the detection of  $V_{reg(3.3)}$  lost.

**Table 2. Pin States in Disable or Sharing Mode**

PINS	DISABLE-MODE STATE	SHARING-MODE STATE
$V_{CC(5.0)}/V_{reg(3.3)}$	5-V input/3.3-V output, 3.3-V input/3.3-V input	Not present
$V_{CC(I/O)}$	Not present	1.65-V to 3.6-V input
$V_{pu(3.3)}$	High impedance (off)	High impedance (off)
D+, D–	High impedance	High impedance
VP, VM	Invalid <sup>(1)</sup>	H
RCV	Invalid <sup>(2)</sup>	L
Inputs (VO/VPO, FSE0/VMO, SPEED, SUSPND, OE, SOFTCON)	High impedance	High impedance

(1) High impedance or driven LOW

(2) High impedance or driven LOW

**Table 3. Power-Supply Configuration Overview**

$V_{CC(5.0)}$ or $V_{reg(3.3)}$	$V_{CC(I/O)}$	CONFIGURATION	SPECIAL CHARACTERISTICS
Connected	Connected	Normal mode	
Connected	Not connected	Disable mode	D+, D–, and $V_{pu(3.3)}$ are in high impedance. VP, VM, and RCV are invalid. <sup>(1)</sup>
Not connected	Connected	Sharing mode	D+, D–, and $V_{pu(3.3)}$ are in high impedance. VP and VM are driven HIGH. RCV is driven LOW.

(1) High impedance or driven LOW

### Power-Supply Input Options

The TUSB1106-Q1 has two power-supply input options.

- Internal regulator –  $V_{CC(5.0)}$  is connected to 4 V to 5.5 V. The internal regulator is used to supply the internal circuitry with 3.3 V (nominal).  $V_{reg(3.3)}$  becomes a 3.3-V output reference.
- Regulator bypass –  $V_{CC(5.0)}$  and  $V_{reg(3.3)}$  are connected to the same supply. The internal regulator is bypassed and the internal circuitry is supplied directly from the  $V_{reg(3.3)}$  power supply. The voltage range is 3 V to 3.6 V to comply with the USB specification.

The supply-voltage range for each input option is specified in [Table 4](#).

**Table 4. Power-Supply Input Options**

INPUT OPTION	$V_{CC(5.0)}$	$V_{REG(3.3)}$	$V_{CC(I/O)}$
Internal regulator	Supply input for internal regulator (4 V to 5.5 V)	Voltage-reference output (3.3 V, 300 $\mu$ A)	Supply input for digital I/O pins (1.65 V to 3.6 V)
Regulator bypass	Connected to $V_{reg(3.3)}$ with maximum voltage drop of 0.3 V (2.7 V to 3.6 V)	Supply input (3 V to 3.6 V)	Supply input for digital I/O pins (1.65 V to 3.6 V)

**ABSOLUTE MAXIMUM RATINGS<sup>(1)</sup>**

over operating free-air temperature range (unless otherwise noted)

		MIN	MAX	UNIT
$V_{CC(5.0)}$	Supply voltage range	-0.5	6	V
$V_{I(I/O)}$	Supply voltage range	-0.5	4.6	V
$V_{CCreg(3.3)}$	Regulated voltage range	-0.5	4.6	V
$V_I$	DC input voltage	-0.5	$V_{CC(I/O)} + 0.5$	V
$I_{IK}$	Input clamp current	$V_I = -1.8 \text{ V to } 5.4 \text{ V}$		100 mA
$T_{stg}$	Storage temperature range	-40	125	°C

(1) Stresses beyond those listed under "absolute maximum ratings" may cause permanent damage to the device. These are stress ratings only, and functional operation of the device at these or any other conditions beyond those indicated under "recommended operating conditions" is not implied. Exposure to absolute-maximum-rated conditions for extended periods may affect device reliability.

**RECOMMENDED OPERATING CONDITIONS**

		MIN	NOM	MAX	UNIT		
$V_{CC(5.0)}$	Supply voltage, internal regulator option	5-V operation		4	5	5.5	V
$V_{CCreg(3.3)}$	Supply voltage, regulator bypass option	3.3-V operation		3	3.3	3.6	V
$V_{CC(I/O)}$	I/O supply voltage			1.65		3.6	V
$V_I$	I/O supply voltage			0		$V_{CC(I/O)}$	V
$V_{I/O}$	Input voltage on analog I/O pins (D+, D-)			0		3.6	V
$T_c$	Junction temperature			-40		85	°C

## STATIC ELECTRICAL CHARACTERISTICS – SUPPLY PINS

over recommended ranges of operating free-air temperature and supply voltage (unless otherwise noted)

PARAMETER		TEST CONDITIONS		MIN	TYP	MAX	UNIT
$V_{reg(3.3)}$	Regulated supply-voltage output	Internal regulator option, $I_{load} \leq 300 \mu A$ <sup>(1)</sup> <sup>(2)</sup>		3	3.3	3.6	V
$I_{CC}$	Operating supply current	Full-speed transmitting and receiving at 12 Mbit/s, $C_L = 50$ pF on D+ and D- <sup>(3)</sup>			6	8	mA
$I_{CC(I/O)}$	Operating I/O supply current	Full-speed transmitting and receiving at 12 Mbit/s <sup>(3)</sup>			2.3	2.5	mA
$I_{CC(idle)}$	Supply current during full-speed idle and SE0	Full-speed idle: $V_{D+} > 2.7$ V, $V_{D-} < 0.3$ V SE0: $V_{D+} < 0.3$ V, $V_{D-} < 0.3$ V <sup>(4)</sup>				500	$\mu A$
$I_{CC(I/O)(static)}$	Static I/O supply current	Full-speed idle, SE0 or suspend			10	22	$\mu A$
$I_{CC(susp)}$	Suspend supply current	SUSPND = HIGH <sup>(4)</sup>			10	22	$\mu A$
$I_{CC(dis)}$	Disable-mode supply current	$V_{CC(I/O)}$ not connected <sup>(4)</sup>			10	22	$\mu A$
$I_{CC(I/O)(sharing)}$	Sharing-mode I/O supply current	$V_{CC(5.0)}$ or $V_{reg(3.3)}$ not connected			10	22	$\mu A$
$I_{Dx(sharing)}$	Sharing-mode load current on D+ and D-	$V_{CC(5.0)}$ or $V_{reg(3.3)}$ not connected, SOFTCON = LOW, $V_{Dx} = 3.6$ V				10	$\mu A$
$V_{reg(3.3)th}$	Regulated supply-voltage detection threshold	$1.65$ V $\leq V_{CC(I/O)} \leq V_{reg(3.3)}$ , $2.7$ V $\leq V_{reg(3.3)} \leq 3.6$ V	Supply lost during power down			0.8	V
			Supply detect during power up <sup>(5)</sup>	2.4			
$V_{reg(3.3)hys}$	Regulated supply-voltage detection hysteresis	$V_{CC(I/O)} = 1.8$ V			0.45		V
$V_{CC(I/O)th}$	I/O supply-voltage detection threshold	$V_{reg(3.3)} = 2.7$ V to 3.6 V	Supply lost during power down			0.5	V
			Supply detect during power up	1.4			
$V_{CC(I/O)hys}$	I/O supply-voltage detection hysteresis	$V_{reg(3.3)} = 3.3$ V			0.45		V

(1)  $I_{load}$  includes the pullup resistor current via  $V_{pu(3.3)}$ .

(2) In suspend mode, the typical voltage is 2.8 V.

(3) Maximum value is characterized only, not tested in production.

(4) Excluding any load current and  $V_{pu(3.3)}/V_{sw}$  source current to the 1.5-k $\Omega$  and 15-k $\Omega$  pullup and pulldown resistors (200  $\mu A$  typ)

(5) When  $V_{CC(I/O)} < 2.7$  V, the minimum value for  $V_{reg(3.3)th}$  (present) is 2 V.

## STATIC ELECTRICAL CHARACTERISTICS – DIGITAL PINS

over recommended ranges of operating free-air temperature and supply voltage (unless otherwise noted)

PARAMETER		TEST CONDITIONS	$V_{CC(I/O)}$	MIN	MAX	UNIT
$V_{IL}$	LOW-level input voltage		1.65 V to 3.6 V		$0.3 V_{CC(I/O)}$	V
$V_{IH}$	HIGH-level input voltage		1.65 V to 3.6 V	$0.6 V_{CC(I/O)}$		V
$V_{OL}$	LOW-level output voltage	$I_{OL} = 100 \mu A$	1.65 V to 3.6 V		0.15	V
		$I_{OL} = 2 \text{ mA}$			0.4	
		$I_{OL} = 100 \mu A$	1.8 V $\pm$ 0.15 V		0.15	
		$I_{OL} = 2 \text{ mA}$			0.4	
		$I_{OL} = 100 \mu A$	2.5 V $\pm$ 0.2 V		0.15	
		$I_{OL} = 2 \text{ mA}$			0.4	
		$I_{OL} = 100 \mu A$	3.3 V $\pm$ 0.3 V		0.15	
		$I_{OL} = 2 \text{ mA}$			0.4	
$V_{OH}$	HIGH-level output voltage	$I_{OH} = 100 \mu A$	1.65 V to 3.6 V	$V_{CC(I/O)} - 0.15$		V
		$I_{OH} = 2 \text{ mA}$		$V_{CC(I/O)} - 0.4$		
		$I_{OH} = 100 \mu A$	1.8 V $\pm$ 0.15 V		1.5	
		$I_{OH} = 2 \text{ mA}$			1.25	
		$I_{OH} = 100 \mu A$	2.5 V $\pm$ 0.2 V		2.15	
		$I_{OH} = 2 \text{ mA}$			1.9	
		$I_{OH} = 100 \mu A$	3.3 V $\pm$ 0.3 V		2.85	
		$I_{OH} = 2 \text{ mA}$			2.6	
$I_{LI}$	Input leakage current			-1	1	$\mu A$
$C_{IN}$	Input capacitance	Pin to GND			3.5	pF

## STATIC ELECTRICAL CHARACTERISTICS – ANALOG I/O PINS

over recommended ranges of operating free-air temperature and supply voltage,  $V_{CC} = 4\text{ V to }5.5\text{ V}$  or  $V_{reg(3.3)} = 3\text{ V to }3.6\text{ V}$ ,  $V_{GND} = 0\text{ V}$ ,  $T_A = -40^\circ\text{C to }85^\circ\text{C}$  (unless otherwise noted)

PARAMETER		TEST CONDITIONS	MIN	TYP	MAX	UNIT
$V_{DI}$	Differential input sensitivity	$ V_{I(D+)} - V_{I(D-)} $	0.2			V
$V_{CM}$	Differential common-mode voltage	Includes $V_{DI}$ range	0.8		2.5	V
$V_{IL}$	LOW-level input voltage, single-ended receiver		2		0.8	V
$V_{IH}$	HIGH-level input voltage, single-ended receiver		0.4			V
$V_{hys}$	Hysteresis voltage, single-ended receiver				0.7	V
$V_{OL}$	LOW-level output voltage	$R_L = 1.5\text{ k}\Omega$ to $3.6\text{ V}$			0.3	V
$V_{OH}$	HIGH-level output voltage	$R_L = 1.5\text{ k}\Omega$ to GND	2.8 <sup>(1)</sup>		3.6	V
$I_{LZ}$	OFF-state leakage current				1	$\mu\text{A}$
$C_{IN}$	Transceiver capacitance	Pin to GND			25	pF
$Z_{DRV}$	Driver output impedance	Steady-state drive	34 <sup>(2)</sup>	39	44	$\Omega$
$Z_{INP}$	Input impedance		10			M $\Omega$
$R_{SW}$	Internal switch resistance at $V_{pu(3.3)}$				13	$\Omega$
$V_{TERM}$	Termination voltage for upstream port pullup (RPU)		3 <sup>(3)</sup> <sup>(4)</sup>		3.6	V

(1)  $V_{OH(min)} = V_{reg(3.3)} - 0.2\text{ V}$

(2) Includes external resistors of  $33\ \Omega \pm 1\%$  on both D+ and D-

(3) This voltage is available at  $V_{reg(3.3)}$  and  $V_{pu(3.3)}$ .

(4) In suspend mode, the minimum voltage is 2.7 V.

## DYNAMIC ELECTRICAL CHARACTERISTICS – ANALOG I/O PINS (D+, D–)<sup>(1) (2)</sup>

### Driver Characteristics, Full-Speed Mode

over recommended ranges of operating free-air temperature and supply voltage,  $V_{CC} = 4\text{ V to }5.5\text{ V}$  or  $V_{reg(3.3)} = 3\text{ V to }3.6\text{ V}$ ,  $V_{CC(I/O)} = 1.65\text{ V to }3.6\text{ V}$ ,  $V_{GND} = 0\text{ V}$ , see Table 10 for valid voltage level combinations,  $T_A = -40^\circ\text{C to }85^\circ\text{C}$  (unless otherwise noted)

PARAMETER		TEST CONDITIONS	MIN	MAX	UNIT
$t_{FR}$	Rise time	$C_L = 50\text{ pF to }125\text{ pF}$ , 10% to 90% of $ V_{OH} - V_{OL} $ (see Figure 1)	4	20	ns
$t_{FF}$	Fall time	$C_L = 50\text{ pF to }125\text{ pF}$ , 90% to 10% of $ V_{OH} - V_{OL} $ (see Figure 1)	4	20	ns
FRFM	Differential rise/fall time matching ( $t_{FR}/t_{FF}$ )	Excluding the first transition from idle state	90	111.1	%
$V_{CRS}$	Output signal crossover voltage	Excluding the first transition from idle state (see Figure 10)	1.3	2	V

(1) Test circuit, see Figure 13

(2) Driver timing in low-speed mode is not specified. Low-speed delay timings are dominated by the slow rise/fall times  $t_{LR}$  and  $t_{LF}$ .

## DYNAMIC ELECTRICAL CHARACTERISTICS – ANALOG I/O PINS (D+, D–)<sup>(1) (2)</sup>

### Driver Characteristics, Low-Speed Mode

over recommended ranges of operating free-air temperature and supply voltage,  $V_{CC} = 4\text{ V to }5.5\text{ V}$  or  $V_{reg(3.3)} = 3\text{ V to }3.6\text{ V}$ ,  $V_{CC(I/O)} = 1.65\text{ V to }3.6\text{ V}$ ,  $V_{GND} = 0\text{ V}$ , see Table 10 for valid voltage level combinations,  $T_A = -40^\circ\text{C to }85^\circ\text{C}$  (unless otherwise noted)

PARAMETER		TEST CONDITIONS	MIN	MAX	UNIT
$t_{LR}$	Rise time	$C_L = 200\text{ pF to }600\text{ pF}$ , 10% to 90% of $ V_{OH} - V_{OL} $ (see Figure 1)	75	300	ns
$t_{LF}$	Fall time	$C_L = 200\text{ pF to }600\text{ pF}$ , 90% to 10% of $ V_{OH} - V_{OL} $ (see Figure 1)	75	300	ns
LRFM	Differential rise/fall time matching ( $t_{LR}/t_{LF}$ )	Excluding the first transition from idle state	80	125	%
$V_{CRS}$	Output signal crossover voltage	Excluding the first transition from idle state (see Figure 10)	1.3	2	V

(1) Test circuit, see Figure 13

(2) Driver timing in low-speed mode is not specified. Low-speed delay timings are dominated by the slow rise/fall times  $t_{LR}$  and  $t_{LF}$ .

## DYNAMIC ELECTRICAL CHARACTERISTICS – ANALOG I/O PINS (D+, D–)<sup>(1) (2)</sup>

### Driver Timing, Full-Speed Mode

over recommended ranges of operating free-air temperature and supply voltage,  $V_{CC} = 4\text{ V to }5.5\text{ V}$  or  $V_{reg(3.3)} = 3\text{ V to }3.6\text{ V}$ ,  $V_{CC(I/O)} = 1.65\text{ V to }3.6\text{ V}$ ,  $V_{GND} = 0\text{ V}$ , see Table 10 for valid voltage level combinations,  $T_A = -40^\circ\text{C to }85^\circ\text{C}$  (unless otherwise noted)

PARAMETER		TEST CONDITIONS	MIN	MAX	UNIT
$t_{PLH(drv)}$	Driver propagation delay (VO/VPO, FSE0/VMO to D+, D–)	LOW to HIGH (see Figure 4)		18	ns
$t_{PHL(drv)}$		HIGH to LOW (see Figure 4)		18	
$t_{PHZ}$	Driver disable delay ( $\overline{OE}$ to D+, D–)	HIGH to OFF (see Figure 2)		15	ns
$t_{PLZ}$		LOW to OFF (see Figure 2)		15	
$t_{PZH}$	Driver enable delay ( $\overline{OE}$ to D+, D–)	OFF to HIGH (see Figure 2)		15	ns
$t_{PZL}$		OFF to LOW (see Figure 2)		15	

(1) Test circuit, see Figure ?

(2) Driver timing in low-speed mode is not specified. Low-speed delay timings are dominated by the slow rise/fall times  $t_{LR}$  and  $t_{LF}$ .

### DYNAMIC ELECTRICAL CHARACTERISTICS FOR ANALOG I/O PINS (D+, D-)<sup>(1)</sup> Receiver Timing, Full-Speed and Low-Speed Mode, Differential Receiver

over recommended ranges of operating free-air temperature and supply voltage,  $V_{CC} = 4\text{ V to }5.5\text{ V}$  or  $V_{reg(3.3)} = 3\text{ V to }3.6\text{ V}$ ,  $V_{CC(I/O)} = 1.65\text{ V to }3.6\text{ V}$ ,  $V_{GND} = 0\text{ V}$ , see Table 10 for valid voltage level combinations,  $T_A = -40^\circ\text{C to }85^\circ\text{C}$  (unless otherwise noted)

PARAMETER		TEST CONDITIONS	MIN	MAX	UNIT
$t_{PLH(rcv)}$	Propagation delay (D+, D- to RCV)	LOW to HIGH (see Figure 3)		15	ns
$t_{PHL(rcv)}$		HIGH to LOW (see Figure 3)		15	

(1) Test circuit, see Figure ?

### DYNAMIC ELECTRICAL CHARACTERISTICS FOR ANALOG I/O PINS (D+, D-)<sup>(1)</sup> Receiver Timing, Full-Speed and Low-Speed Mode, Single-Ended Receiver

over recommended ranges of operating free-air temperature and supply voltage,  $V_{CC} = 4\text{ V to }5.5\text{ V}$  or  $V_{reg(3.3)} = 3\text{ V to }3.6\text{ V}$ ,  $V_{CC(I/O)} = 1.65\text{ V to }3.6\text{ V}$ ,  $V_{GND} = 0\text{ V}$ , see Table 10 for valid voltage level combinations,  $T_A = -40^\circ\text{C to }85^\circ\text{C}$  (unless otherwise noted)

PARAMETER		TEST CONDITIONS	MIN	MAX	UNIT
$t_{PLH(se)}$	Propagation delay (D+, D- to VP, VM)	LOW to HIGH (see Figure 3)		18	ns
$t_{PHL(se)}$		HIGH to LOW (see Figure 3)		18	

(1) Test circuit, see Figure 13

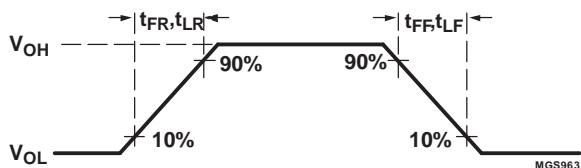


Figure 1. Rise and Fall Times

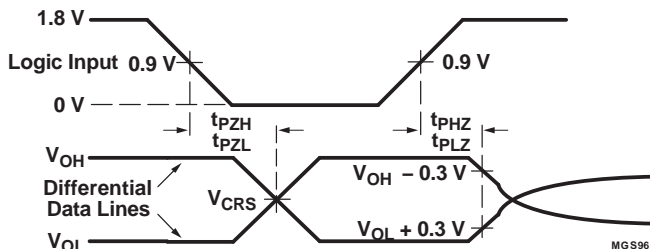


Figure 2.  $\overline{OE}$  to D+, D-

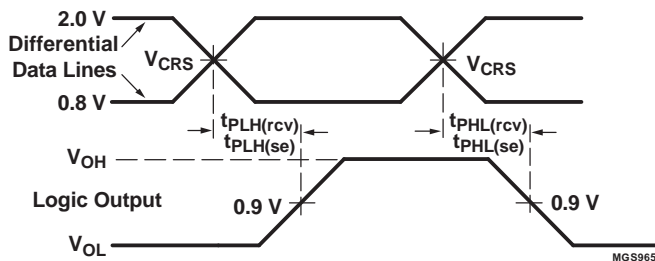


Figure 3. D+, D- to RCV, VP, VM

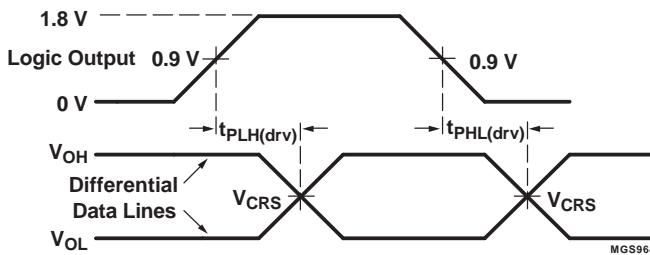
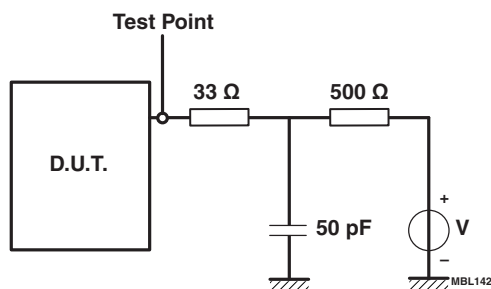


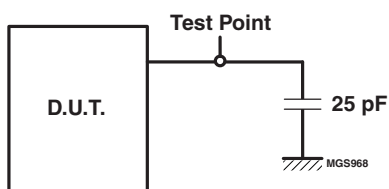
Figure 4. VO/VPO, FSE0/VM0 to D+, D-

## APPLICATION INFORMATION

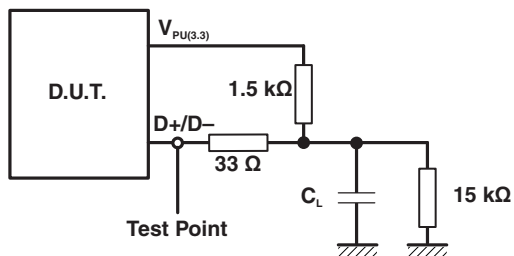


**Figure 5. Load for Enable and Disable Times**

- A.  $V = 0\text{ V}$  for  $t_{pZH}$ ,  $t_{pHZ}$
- B.  $V = V_{\text{reg}(3.3)}$  for  $t_{pZL}$ ,  $t_{pLZ}$



**Figure 6. Load for VM, VP, and RCV**



**Figure 7. Load for D+, D–**

- A. Full-speed mode: connected to D+
- B. Low-speed mode: Connected to D–
- C. Load capacitance:
  - $C_L = 50\text{ pF}$  or  $125\text{ pF}$  (full-speed mode, minimum or maximum timing)
  - $C_L = 200\text{ pF}$  or  $600\text{ pF}$  (low-speed mode, minimum or maximum timing)

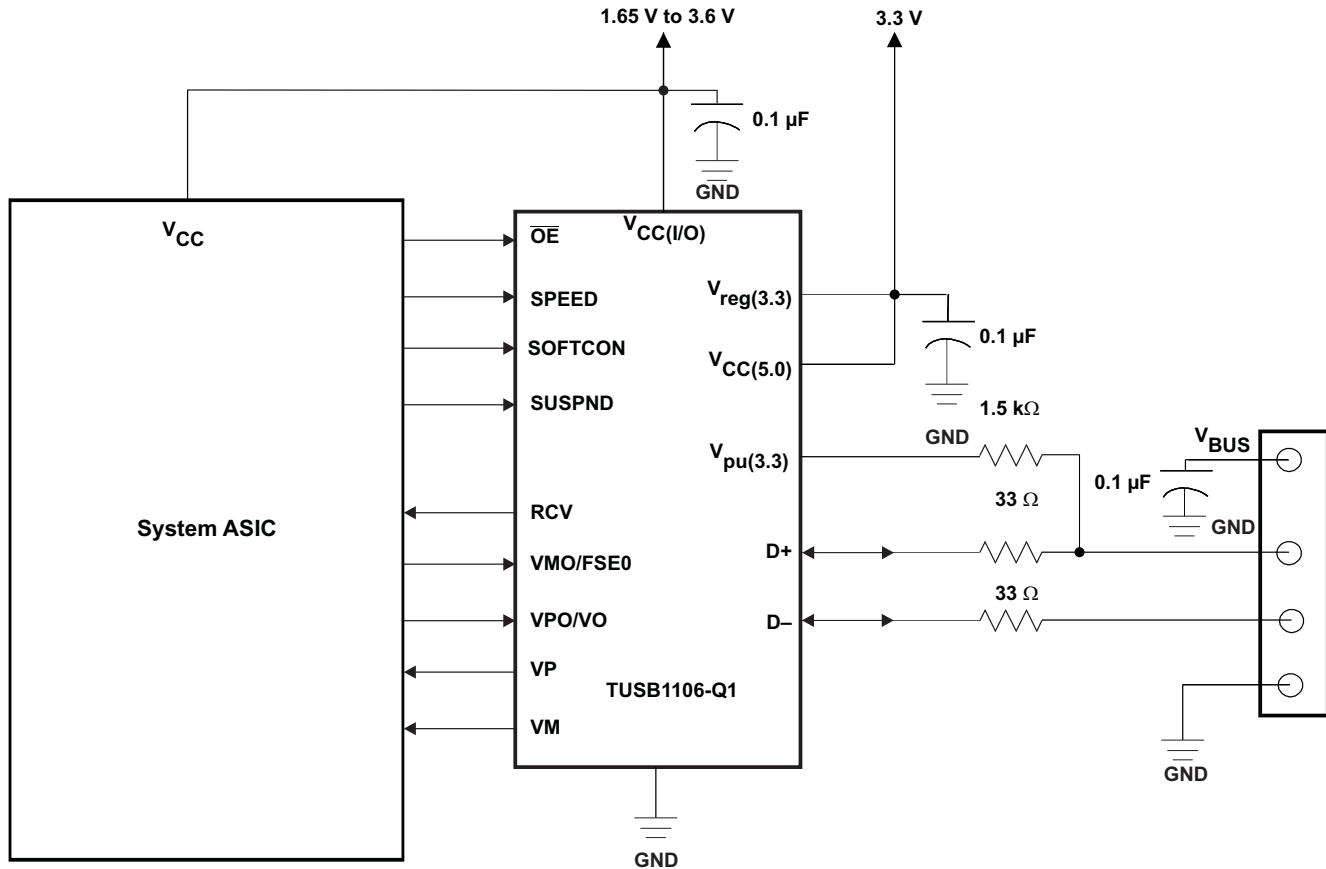
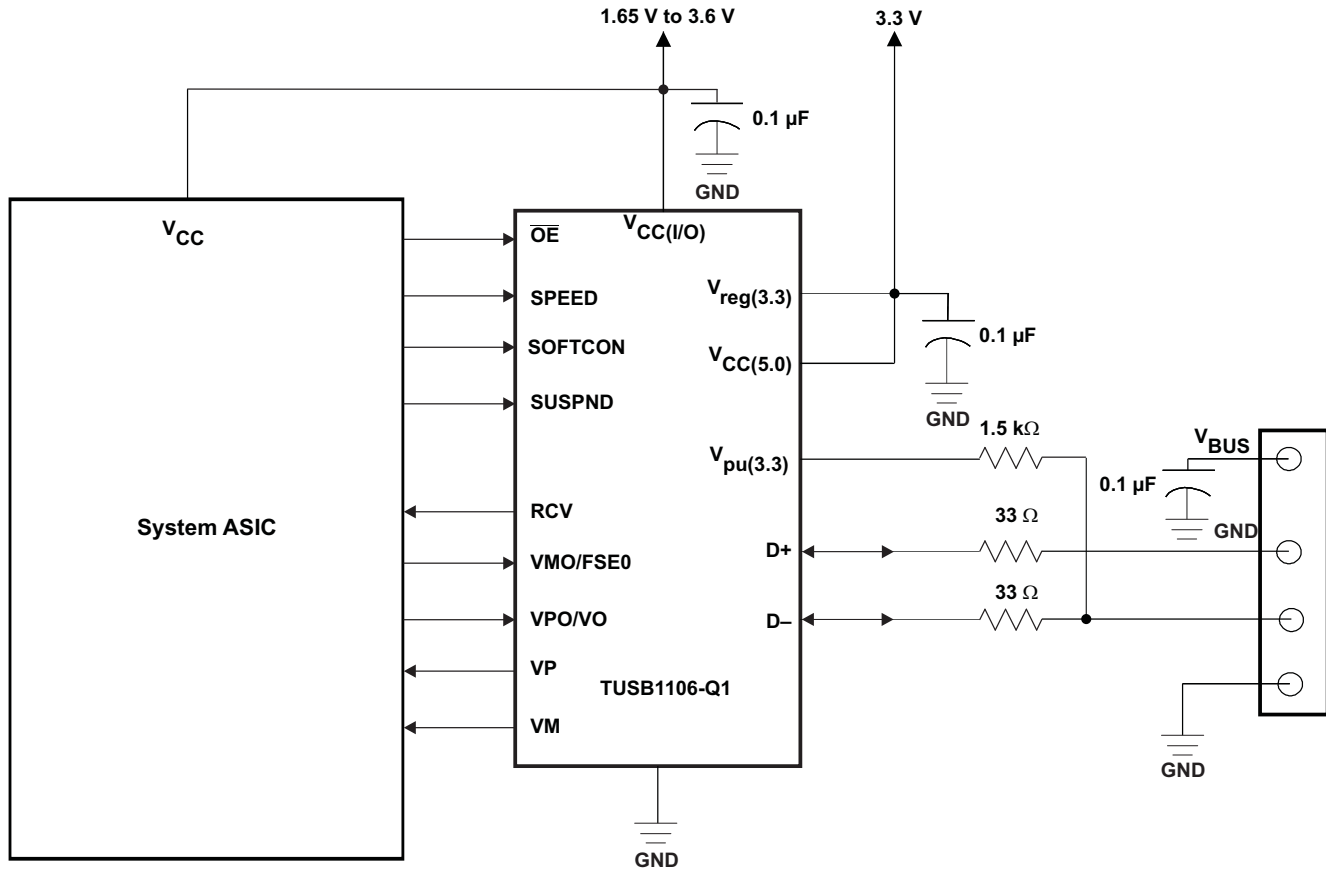


Figure 8. Peripheral-Side (Full-Speed) Regulator Bypass Mode

### Peripheral-Side (Full-Speed) Regulator Bypass Mode

This mode is applicable when there is a 3.3-V supply already available on the board. The  $V_{BUS}$  pin of the USB connector, if left unused at the peripheral side, should be terminated with a 0.1- $\mu$ F capacitor. While operating at full speed, the 1.5-k $\Omega$  resistor must be connected between the D+ line and  $V_{PU(3.3)}$  or an external 3.3-V supply. When the  $V_{CC(5.0)}$  and the  $V_{reg(3.3)}$  are connected together, the device operates at regulator bypass mode. This enables power savings since the regulator is turned off.



**Figure 9. Peripheral-Side (Low-Speed) Regulator Bypass Mode**

### Peripheral-Side (Low-Speed) Regulator Bypass Mode

This mode is applicable when there is a 3.3-V supply already available on the board. The  $V_{BUS}$  pin of the USB connector, if left unused at the peripheral side, should be terminated with a 0.1- $\mu$ F capacitor. While operating at low speed, the 1.5-k $\Omega$  resistor must be connected between the D– line and  $V_{PU(3.3)}$  or an external 3.3-V supply. When the  $V_{CC(5.0)}$  and the  $V_{reg(3.3)}$  are connected together, the device operates at regulator bypass mode. This enables power savings since the regulator is turned off.

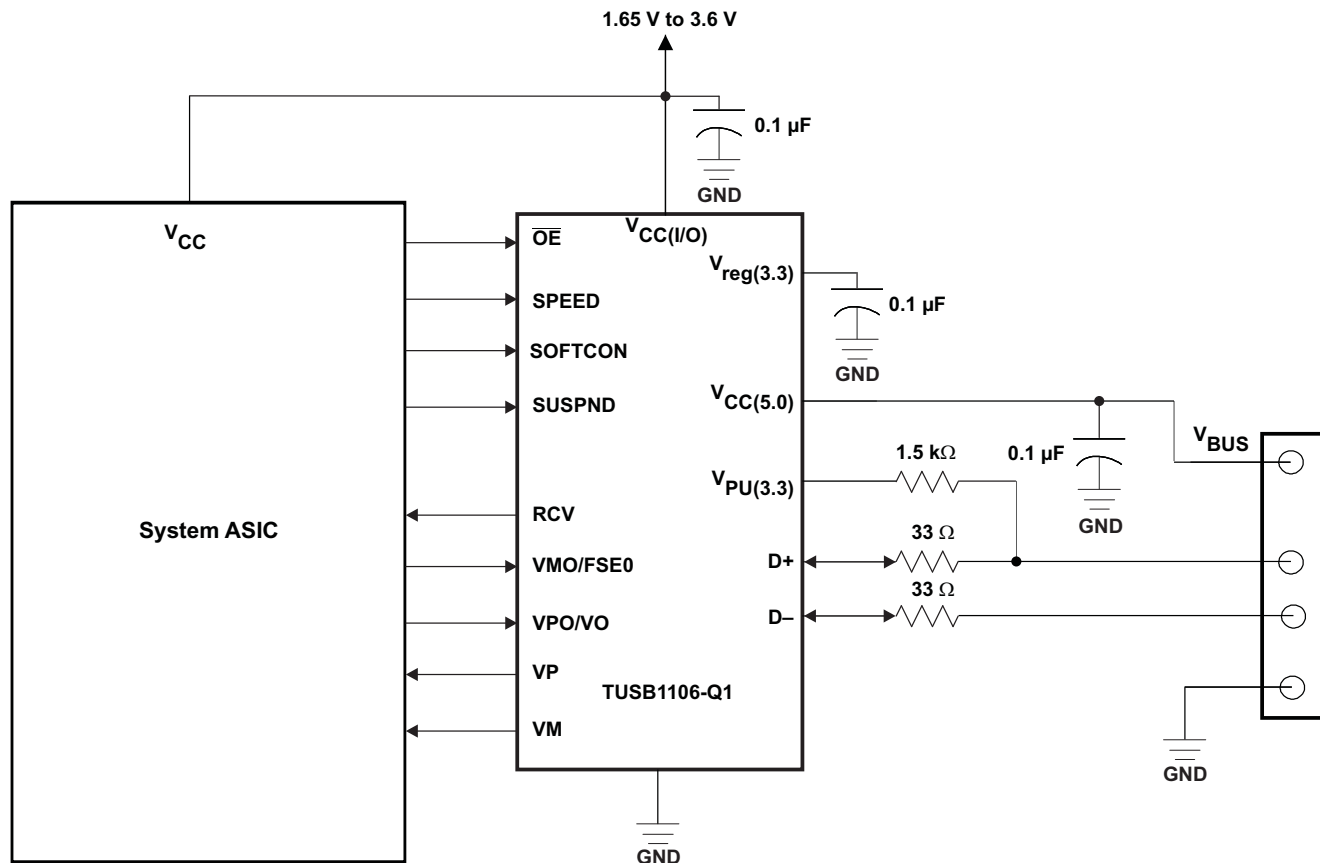
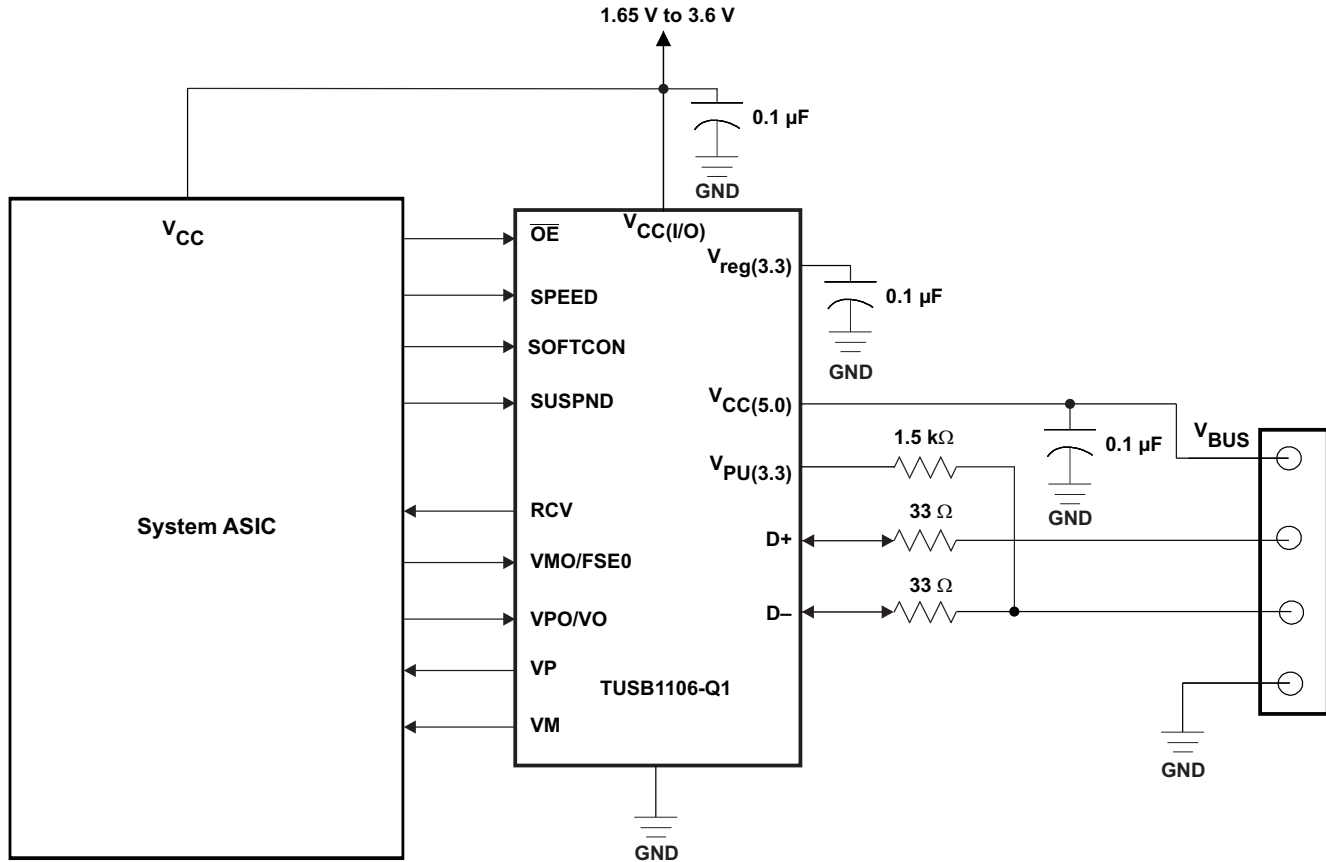


Figure 10. Peripheral-Side (Full-Speed) Internal Regulator Mode

### Peripheral-Side (Full-Speed) Internal Regulator Mode

The USB side of the TUSB1106-Q1 can be powered from the  $V_{BUS}$  line directly if a 3.3-V supply is not present on board. In this case, the internal regulator can be used to provide the 3.3-V supply for USB signaling. The  $V_{CC(5.0)}$  is connected to the  $V_{BUS}$ , which receives 5-V supply from the host, and generates the 3.3-V output at the  $V_{reg(3.3)}$  pin. In this mode, it is important that both  $V_{CC(5.0)}$  and  $V_{reg(3.3)}$  pins have individual bypass capacitors in the range of 0.1  $\mu\text{F}$ . Powering  $V_{CC(5.0)}$  through the  $V_{BUS}$  port of the USB connector realizes significant power saving for portable applications, such as cell phones, PDAs, etc. In this operating mode, the  $I_{CC(5.0)}$  current is fed from the host. The USB-side power consumption,  $I_{CC(5.0)}$  is 4 mA (with the regulator active), as opposed to logic-side  $I_{CC(I/O)}$  of 1 mA under full-speed operation. While operating at full speed, the 1.5-k $\Omega$  resistor must be connected between the D+ line and the  $V_{PU(3.3)}$  or an external 3.3-V supply.



**Figure 11. Peripheral-Side (Low-Speed) Internal Regulator Mode**

### Peripheral-Side (Low-Speed) Internal Regulator Mode

The USB side of the TUSB1106-Q1 can be powered from the  $V_{BUS}$  line directly if a 3.3-V supply is not present on board. In this case, the internal regulator can be used to provide the 3.3-V supply for the USB signaling. The  $V_{CC(5.0)}$  is connected to the  $V_{BUS}$ , which receives 5-V supply from the host, and generates the 3.3-V output at the  $V_{reg(3.3)}$  pin. In this mode, it is important that both  $V_{CC(5.0)}$  and  $V_{reg(3.3)}$  pins have individual bypass capacitors in the range of 0.1  $\mu\text{F}$ . Powering  $V_{CC(5.0)}$  through the  $V_{BUS}$  port of the USB connector realizes significant power saving for portable applications, such as cell phones, PDAs, etc. In this operating mode, the  $I_{CC(5.0)}$  current is fed from the host side. The USB-side power consumption,  $I_{CC(5.0)}$  is 4 mA (with the regulator active), as opposed to logic-side  $I_{CC(I/O)}$  of 1 mA under full-speed operation. While operating at low speed, the 1.5-k $\Omega$  resistor must be connected between the D- line and the  $V_{PU(3.3)}$  or an external 3.3-V supply.

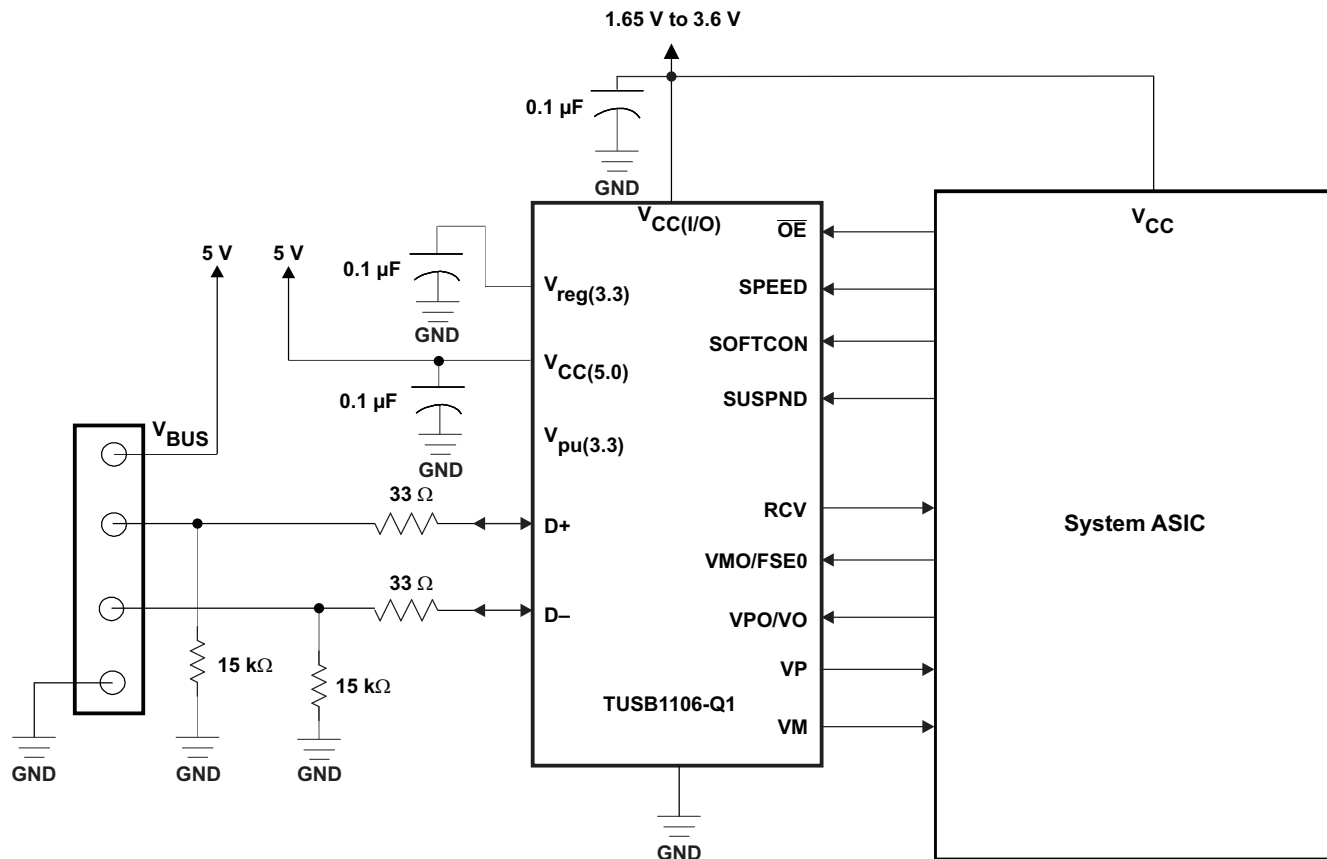


Figure 12. Host Side ( $V_{CC(5.0)}$  Supplied From  $V_{BUS}$  Pin)

### Host Side ( $V_{CC(5.0)}$ Supplied From $V_{BUS}$ Pin)

If there is no 3.3-V supply on board, an external 5-V supply can support the USB-side power needs. When the  $V_{CC(5.0)}$  is connected to an external 5-V supply, the on-chip regulator generates the 3.3-V internal supply rail, which is used to drive the USB signaling levels at the USB side of the TUSB1106-Q1. The logic-side I/Os can operate at any voltage range from 1.65 V to 3.6 V.

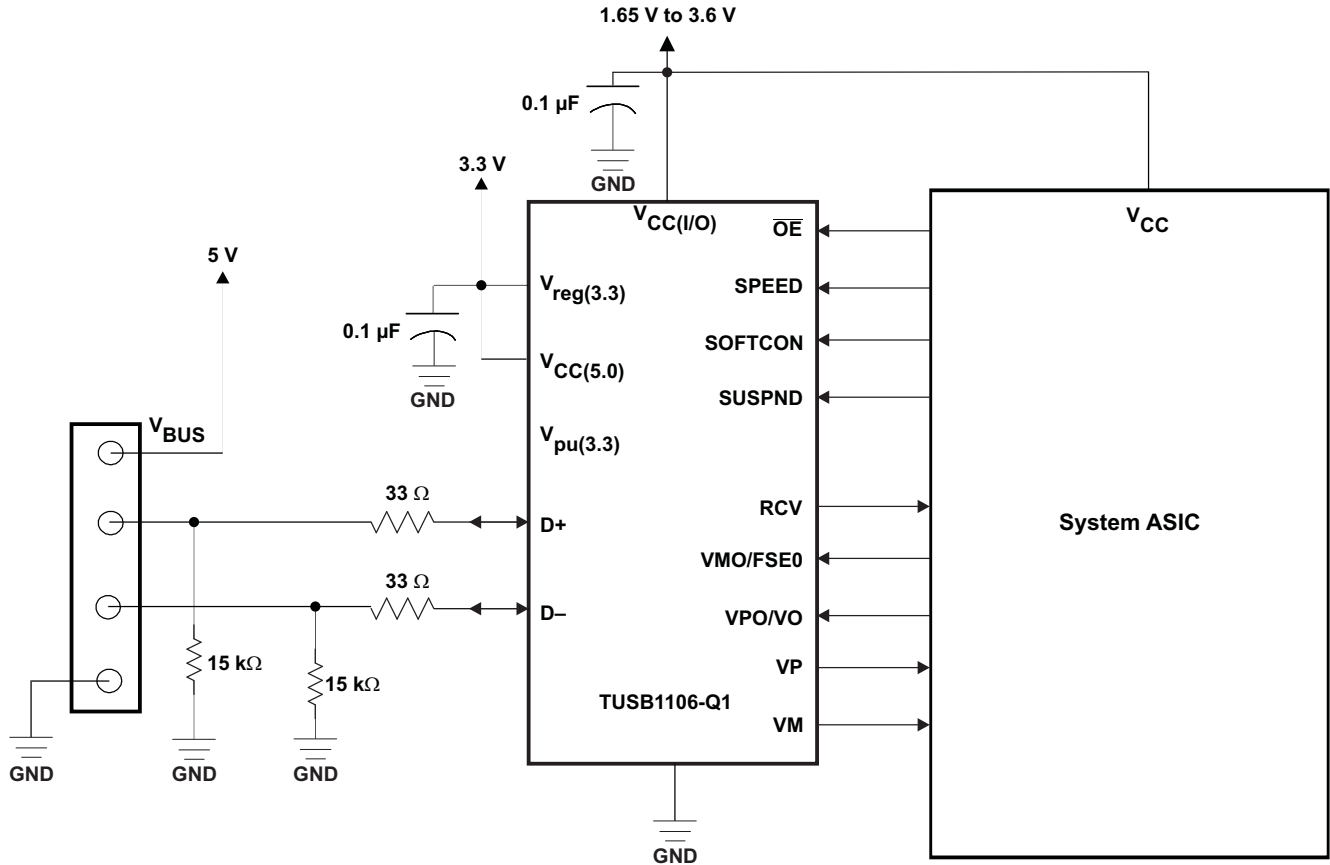


Figure 13. Host-Side (3.3-V Supply Present) Internal Regulator Bypass Mode

### Host-Side (3.3-V Supply Present) Internal Regulator Bypass Mode

If a 3.3-V supply supports the USB-side power,  $V_{CC(5.0)}$  and  $V_{reg(3.3)}$  must to be tied together and connected to a 3.3-V supply. It also makes the regulator inactive.

**PACKAGING INFORMATION**

Orderable Device	Status (1)	Package Type	Package Drawing	Pins	Package Qty	Eco Plan (2)	Lead/Ball Finish	MSL Peak Temp (3)	Op Temp (°C)	Top-Side Markings (4)	Samples
TUSB1106IPWRQ1	ACTIVE	TSSOP	PW	16	2000	Green (RoHS & no Sb/Br)	CU NIPDAU	Level-1-260C-UNLIM	-40 to 85	TU1106I	Samples

(1) The marketing status values are defined as follows:

**ACTIVE:** Product device recommended for new designs.

**LIFEBUY:** TI has announced that the device will be discontinued, and a lifetime-buy period is in effect.

**NRND:** Not recommended for new designs. Device is in production to support existing customers, but TI does not recommend using this part in a new design.

**PREVIEW:** Device has been announced but is not in production. Samples may or may not be available.

**OBSOLETE:** TI has discontinued the production of the device.

(2) Eco Plan - The planned eco-friendly classification: Pb-Free (RoHS), Pb-Free (RoHS Exempt), or Green (RoHS & no Sb/Br) - please check <http://www.ti.com/productcontent> for the latest availability information and additional product content details.

**TBD:** The Pb-Free/Green conversion plan has not been defined.

**Pb-Free (RoHS):** TI's terms "Lead-Free" or "Pb-Free" mean semiconductor products that are compatible with the current RoHS requirements for all 6 substances, including the requirement that lead not exceed 0.1% by weight in homogeneous materials. Where designed to be soldered at high temperatures, TI Pb-Free products are suitable for use in specified lead-free processes.

**Pb-Free (RoHS Exempt):** This component has a RoHS exemption for either 1) lead-based flip-chip solder bumps used between the die and package, or 2) lead-based die adhesive used between the die and leadframe. The component is otherwise considered Pb-Free (RoHS compatible) as defined above.

**Green (RoHS & no Sb/Br):** TI defines "Green" to mean Pb-Free (RoHS compatible), and free of Bromine (Br) and Antimony (Sb) based flame retardants (Br or Sb do not exceed 0.1% by weight in homogeneous material)

(3) MSL, Peak Temp. -- The Moisture Sensitivity Level rating according to the JEDEC industry standard classifications, and peak solder temperature.

(4) Multiple Top-Side Markings will be inside parentheses. Only one Top-Side Marking contained in parentheses and separated by a "~" will appear on a device. If a line is indented then it is a continuation of the previous line and the two combined represent the entire Top-Side Marking for that device.

**Important Information and Disclaimer:**The information provided on this page represents TI's knowledge and belief as of the date that it is provided. TI bases its knowledge and belief on information provided by third parties, and makes no representation or warranty as to the accuracy of such information. Efforts are underway to better integrate information from third parties. TI has taken and continues to take reasonable steps to provide representative and accurate information but may not have conducted destructive testing or chemical analysis on incoming materials and chemicals. TI and TI suppliers consider certain information to be proprietary, and thus CAS numbers and other limited information may not be available for release.

In no event shall TI's liability arising out of such information exceed the total purchase price of the TI part(s) at issue in this document sold by TI to Customer on an annual basis.

**OTHER QUALIFIED VERSIONS OF TUSB1106-Q1 :**

- Catalog: [TUSB1106](#)

NOTE: Qualified Version Definitions:

- Catalog - TI's standard catalog product

**TAPE AND REEL INFORMATION**
**REEL DIMENSIONS**

**TAPE DIMENSIONS**


A0	Dimension designed to accommodate the component width
B0	Dimension designed to accommodate the component length
K0	Dimension designed to accommodate the component thickness
W	Overall width of the carrier tape
P1	Pitch between successive cavity centers

**TAPE AND REEL INFORMATION**

\*All dimensions are nominal

Device	Package Type	Package Drawing	Pins	SPQ	Reel Diameter (mm)	Reel Width W1 (mm)	A0 (mm)	B0 (mm)	K0 (mm)	P1 (mm)	W (mm)	Pin1 Quadrant
TUSB1106IPWRQ1	TSSOP	PW	16	2000	330.0	12.4	6.9	5.6	1.6	8.0	12.0	Q1

TAPE AND REEL BOX DIMENSIONS



\*All dimensions are nominal

Device	Package Type	Package Drawing	Pins	SPQ	Length (mm)	Width (mm)	Height (mm)
TUSB1106IPWRQ1	TSSOP	PW	16	2000	367.0	367.0	35.0



4220204/A 02/2017

**NOTES:**

1. All linear dimensions are in millimeters. Any dimensions in parenthesis are for reference only. Dimensioning and tolerancing per ASME Y14.5M.
2. This drawing is subject to change without notice.
3. This dimension does not include mold flash, protrusions, or gate burrs. Mold flash, protrusions, or gate burrs shall not exceed 0.15 mm per side.
4. This dimension does not include interlead flash. Interlead flash shall not exceed 0.25 mm per side.
5. Reference JEDEC registration MO-153.

# EXAMPLE BOARD LAYOUT

PW0016A

TSSOP - 1.2 mm max height

SMALL OUTLINE PACKAGE



LAND PATTERN EXAMPLE  
EXPOSED METAL SHOWN  
SCALE: 10X



4220204/A 02/2017

NOTES: (continued)

- 6. Publication IPC-7351 may have alternate designs.
- 7. Solder mask tolerances between and around signal pads can vary based on board fabrication site.

# EXAMPLE STENCIL DESIGN

PW0016A

TSSOP - 1.2 mm max height

SMALL OUTLINE PACKAGE



SOLDER PASTE EXAMPLE  
BASED ON 0.125 mm THICK STENCIL  
SCALE: 10X

4220204/A 02/2017

NOTES: (continued)

8. Laser cutting apertures with trapezoidal walls and rounded corners may offer better paste release. IPC-7525 may have alternate design recommendations.
9. Board assembly site may have different recommendations for stencil design.

## IMPORTANT NOTICE AND DISCLAIMER

TI PROVIDES TECHNICAL AND RELIABILITY DATA (INCLUDING DATASHEETS), DESIGN RESOURCES (INCLUDING REFERENCE DESIGNS), APPLICATION OR OTHER DESIGN ADVICE, WEB TOOLS, SAFETY INFORMATION, AND OTHER RESOURCES "AS IS" AND WITH ALL FAULTS, AND DISCLAIMS ALL WARRANTIES, EXPRESS AND IMPLIED, INCLUDING WITHOUT LIMITATION ANY IMPLIED WARRANTIES OF MERCHANTABILITY, FITNESS FOR A PARTICULAR PURPOSE OR NON-INFRINGEMENT OF THIRD PARTY INTELLECTUAL PROPERTY RIGHTS.

These resources are intended for skilled developers designing with TI products. You are solely responsible for (1) selecting the appropriate TI products for your application, (2) designing, validating and testing your application, and (3) ensuring your application meets applicable standards, and any other safety, security, or other requirements. These resources are subject to change without notice. TI grants you permission to use these resources only for development of an application that uses the TI products described in the resource. Other reproduction and display of these resources is prohibited. No license is granted to any other TI intellectual property right or to any third party intellectual property right. TI disclaims responsibility for, and you will fully indemnify TI and its representatives against, any claims, damages, costs, losses, and liabilities arising out of your use of these resources.

TI's products are provided subject to TI's Terms of Sale ([www.ti.com/legal/termsofsale.html](http://www.ti.com/legal/termsofsale.html)) or other applicable terms available either on [ti.com](http://ti.com) or provided in conjunction with such TI products. TI's provision of these resources does not expand or otherwise alter TI's applicable warranties or warranty disclaimers for TI products.

Mailing Address: Texas Instruments, Post Office Box 655303, Dallas, Texas 75265  
Copyright © 2018, Texas Instruments Incorporated

## Looking for pricing, stock, or lifecycle information?

Click below to explore more details on WIN SOURCE:

 [View TUSB1106IPWRQ1](#) on WIN SOURCE

 [Texas Instruments](#) Information

## Optimize Your Supply Chain with WIN SOURCE Solutions

-  Global Sourcing Solution
-  Obsolete Management
-  Cost Control Management
-  Shortage Management
-  Alternative Solution
-  Excess Inventory Management