



**THE DATASHEET OF  
TMP75AIDGKTG4**



# TMPx75 Temperature Sensor With I<sup>2</sup>C and SMBus Interface in Industry Standard LM75 Form Factor and Pinout

## 1 Features

- TMP175: 27 Addresses
- TMP75: 8 Addresses, NIST Traceable
- Digital Output: SMBus™, Two-Wire, and I<sup>2</sup>C Interface Compatibility
- Resolution: 9 to 12 Bits, User-Selectable
- Accuracy:
  - ±1°C (Typical) from –40°C to +125°C
  - ±2°C (Maximum) from –40°C to +125°C
- Low Quiescent Current: 50-µA, 0.1-µA Standby
- Wide Supply Range: 2.7 V to 5.5 V
- Small 8-Pin MSOP and 8-Pin SOIC Packages

## 2 Applications

- Power-Supply Temperature Monitoring
- Computer Peripheral Thermal Protection
- Notebook Computers
- Cell Phones
- Battery Management
- Office Machines
- Thermostat Controls
- Environmental Monitoring and HVAC
- Electro Mechanical Device Temperature

## 3 Description

The TMP75 and TMP175 devices are digital temperature sensors ideal for negative temperature coefficient (NTC) and positive temperature coefficient (PTC) thermistor replacement. The devices offer a typical accuracy of ±1°C without requiring calibration or external component signal conditioning. Device temperature sensors are highly linear and do not require complex calculations or look-up tables to derive the temperature. The on-chip 12-bit analog-to-digital converter (ADC) offers resolutions down to 0.0625°C. The devices are available in the industry-standard LM75 SOIC-8 and MSOP-8 footprint.

The TMP175 and TMP75 feature SMBus, two-wire, and I<sup>2</sup>C interface compatibility. The TMP175 device allows up to 27 devices on one bus. The TMP75 allows up to eight on one bus. The TMP175 and TMP75 both feature an SMBus Alert function.

The TMP175 and TMP75 devices are ideal for extended temperature measurement in a variety of communication, computer, consumer, environmental, industrial, and instrumentation applications.

The TMP175 and TMP75 devices are specified for operation over a temperature range of –40°C to +125°C.

The TMP75 production units are 100% tested against sensors that are NIST traceable and are verified with equipment that are NIST traceable through ISO/IEC 17025 accredited calibrations.

**TMP175 and TMP75 Internal Block Diagram**

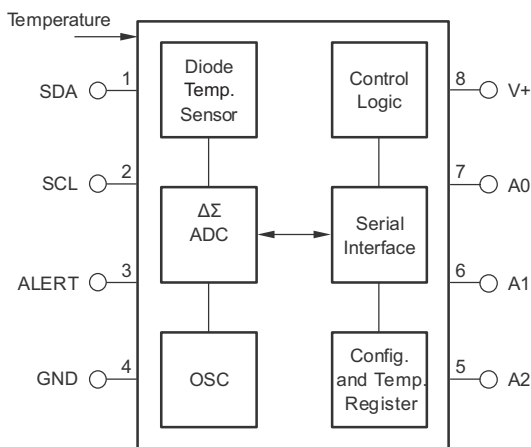

**Device Information<sup>(1)</sup>**

PART NUMBER	PACKAGE	BODY SIZE (NOM)
TMPx75	SOIC (8)	4.90 mm × 3.91 mm
	VSSOP (8)	3.00 mm × 3.00 mm

(1) For all available packages, see the orderable addendum at the end of the data sheet.



## Table of Contents

<b>1 Features</b> .....	<b>1</b>	7.4 Device Functional Modes .....	<b>15</b>
<b>2 Applications</b> .....	<b>1</b>	7.5 Programming .....	<b>16</b>
<b>3 Description</b> .....	<b>1</b>	<b>8 Application and Implementation</b> .....	<b>21</b>
<b>4 Revision History</b> .....	<b>2</b>	8.1 Application Information .....	<b>21</b>
<b>5 Pin Configuration and Functions</b> .....	<b>3</b>	8.2 Typical Application .....	<b>21</b>
<b>6 Specifications</b> .....	<b>4</b>	<b>9 Power Supply Recommendations</b> .....	<b>23</b>
6.1 Absolute Maximum Ratings .....	<b>4</b>	<b>10 Layout</b> .....	<b>23</b>
6.2 ESD Ratings .....	<b>4</b>	10.1 Layout Guidelines .....	<b>23</b>
6.3 Recommended Operating Conditions .....	<b>4</b>	10.2 Layout Example .....	<b>23</b>
6.4 Thermal Information .....	<b>4</b>	<b>11 Device and Documentation Support</b> .....	<b>24</b>
6.5 Electrical Characteristics .....	<b>5</b>	11.1 Related Links .....	<b>24</b>
6.6 Timing Requirements .....	<b>6</b>	11.2 Community Resources .....	<b>24</b>
6.7 Typical Characteristics .....	<b>7</b>	11.3 Trademarks .....	<b>24</b>
<b>7 Detailed Description</b> .....	<b>8</b>	11.4 Electrostatic Discharge Caution .....	<b>24</b>
7.1 Overview .....	<b>8</b>	11.5 Glossary .....	<b>24</b>
7.2 Functional Block Diagram .....	<b>8</b>	<b>12 Mechanical, Packaging, and Orderable Information</b> .....	<b>24</b>
7.3 Feature Description .....	<b>9</b>		

## 4 Revision History

### Changes from Revision K (April 2015) to Revision L

**Page**

• Changed second Features bullet: added NIST Traceable to TMP75 device .....	<b>1</b>
• Added last paragraph to <i>Description</i> section .....	<b>1</b>
• Deleted <i>Simplified Schematic</i> figure from page 1 .....	<b>1</b>
• Changed the <i>Timing Requirements</i> table .....	<b>6</b>
• Changed <a href="#">Figure 6</a> .....	<b>13</b>

### Changes from Revision J (December 2007) to Revision K

**Page**

• Added <i>ESD Ratings</i> table, <i>Feature Description</i> section, <i>Device Functional Modes</i> , <i>Application and Implementation</i> section, <i>Power Supply Recommendations</i> section, <i>Layout</i> section, <i>Device and Documentation Support</i> section, and <i>Mechanical, Packaging, and Orderable Information</i> section. ....	<b>1</b>
• Updated parameters in the <i>Timing Requirements</i> table. ....	<b>6</b>

## 5 Pin Configuration and Functions

**DGK and D Packages  
8-Pin VSSOP and SOIC  
Top View**

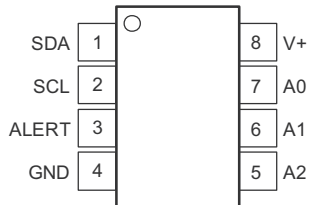

NOTE: Pin 1 is determined by orienting the package marking as indicated in the diagram.

### Pin Functions

PIN		I/O	DESCRIPTION
NO.	NAME		
1	SDA	I/O	Serial data. Open-drain output; requires a pullup resistor.
2	SCL	I	Serial clock. Open-drain output; requires a pullup resistor.
3	ALERT	O	Overtemperature alert. Open-drain output; requires a pullup resistor.
4	GND	—	Ground
5	A2	I	Address select. Connect to GND, V+ or (for the TMP175 device only) leave these pins floating.
6	A1		
7	A0		
8	V+	I	Supply voltage, 2.7 V to 5.5 V

## 6 Specifications

### 6.1 Absolute Maximum Ratings

over operating free-air temperature range (unless otherwise noted)<sup>(1)</sup>

	MIN	MAX	UNIT
Power supply, V+		7	V
Input voltage <sup>(2)</sup>	-0.5	7	V
Input current		10	mA
Operating temperature	-55	127	°C
Junction temperature, T <sub>J</sub>		150	°C
Storage temperature, T <sub>stg</sub>	-60	130	°C

- (1) Stresses beyond those listed under *Absolute Maximum Ratings* may cause permanent damage to the device. These are stress ratings only, which do not imply functional operation of the device at these or any other conditions beyond those indicated under *Recommended Operating Conditions*. Exposure to absolute-maximum-rated conditions for extended periods may affect device reliability.
- (2) Input voltage rating applies to all TMP175 and TMP75 input voltages.

### 6.2 ESD Ratings

		VALUE	UNIT
V <sub>(ESD)</sub>	Electrostatic discharge	Human body model (HBM), per ANSI/ESDA/JEDEC JS-001 <sup>(1)</sup>	±4000
		Charged device model (CDM), per JEDEC specification JESD22-C101 <sup>(2)</sup>	±1000
		Machine model (MM)	±300

- (1) JEDEC document JEP155 states that 500-V HBM allows safe manufacturing with a standard ESD control process.
- (2) JEDEC document JEP157 states that 250-V CDM allows safe manufacturing with a standard ESD control process.

### 6.3 Recommended Operating Conditions

over operating free-air temperature range (unless otherwise noted)

	MIN	NOM	MAX	UNIT
Supply voltage	2.7		5.5	V
Operating free-air temperature, T <sub>A</sub>	-40		125	°C

### 6.4 Thermal Information

THERMAL METRIC <sup>(1)</sup>		TMP175, TMP75	UNIT
		DGK (SOIC), D (VSSOP)	
		8 PINS	
R <sub>θJA</sub>	Junction-to-ambient thermal resistance	185	°C/W
R <sub>θJC(top)</sub>	Junction-to-case (top) thermal resistance	76.1	°C/W
R <sub>θJB</sub>	Junction-to-board thermal resistance	106.4	°C/W
Ψ <sub>JT</sub>	Junction-to-top characterization parameter	14.1	°C/W
Ψ <sub>JB</sub>	Junction-to-board characterization parameter	104.8	°C/W

- (1) For more information about traditional and new thermal metrics, see the *IC Package Thermal Metrics* application report, [SPRA953](#).

## 6.5 Electrical Characteristics

 at  $T_A = -40^\circ\text{C}$  to  $+125^\circ\text{C}$  and  $V_+ = 2.7\text{ V}$  to  $5.5\text{ V}$  (unless otherwise noted)

PARAMETER	TEST CONDITIONS	TMP175			TMP75			UNIT	
		MIN	TYP	MAX	MIN	TYP	MAX		
<b>TEMPERATURE INPUT</b>									
Range		-40		125	-40		125	$^\circ\text{C}$	
Accuracy (temperature error)	$-25^\circ\text{C}$ to $+85^\circ\text{C}$		$\pm 0.5$	$\pm 1.5$		$\pm 0.5$	$\pm 2$	$^\circ\text{C}$	
	$-40^\circ\text{C}$ to $+125^\circ\text{C}$		$\pm 1$	$\pm 2$		$\pm 1$	$\pm 3$		
Accuracy (temperature error) vs supply			0.2	$\pm 0.5$		0.2	$\pm 0.5$	$^\circ\text{C}/\text{V}$	
Resolution <sup>(1)</sup>	Selectable		0.0625			0.0625		$^\circ\text{C}$	
<b>DIGITAL INPUT/OUTPUT</b>									
Input capacitance			3			3		$\mu\text{F}$	
$V_{IH}$	High-level input logic	0.7(V+)		6	0.7(V+)		6	V	
$V_{IL}$	Low-level input logic	-0.5		0.3(V+)	-0.5		0.3(V+)	V	
$I_{IN}$	Leakage input current	$0\text{ V} \leq V_{IN} \leq 6\text{ V}$		1			1	$\mu\text{A}$	
	Input voltage hysteresis	SCL and SDA pins		500		500		mV	
$V_{OL}$	Low-level output logic SDA	$I_{OL} = 3\text{ mA}$	0	0.15	0.4	0	0.15	0.4	V
$V_{OL}$	Low-level output logic ALERT	$I_{OL} = 4\text{ mA}$	0	0.15	0.4	0	0.15	0.4	V
	Resolution	Selectable		9 to 12		9 to 12		Bits	
	Conversion time	9 bits		27.5	37.5		27.5	37.5	ms
		10 bits		55	75		55	75	
		11 bits		110	150		110	150	
		12 bits		220	300		220	300	
	Timeout time		25	54	74	25	54	74	
<b>POWER SUPPLY</b>									
	Operating range		2.7		5.5	2.7		5.5	V
$I_Q$	Quiescent current	Serial bus inactive		50	85		50	85	$\mu\text{A}$
		Serial bus active, SCL frequency = 400 kHz		100			100		
		Serial bus active, SCL frequency = 3.4 MHz		410			410		
$I_{SD}$	Shutdown current	Serial bus inactive		0.1	3		0.1	3	$\mu\text{A}$
		Serial bus active, SCL frequency = 400 kHz		60			60		
		Serial bus active, SCL frequency = 3.4 MHz		380			380		
<b>TEMPERATURE RANGE</b>									
	Specified range		-40		125	-40		125	$^\circ\text{C}$
	Operating range		-55		127	-55		127	$^\circ\text{C}$

(1) Specified for 12-bit resolution.

## 6.6 Timing Requirements

 see the [Timing Diagrams](#) and [Two-Wire Timing Diagrams](#) sections for additional information

			FAST MODE		HIGH-SPEED MODE		UNIT
			MIN	MAX	MIN	MAX	
$f_{(SCL)}$	SCL operating frequency	V+	0.001	0.4	0.001	2.38	MHz
$t_{(BUF)}$	Bus-free time between STOP and START conditions	See the <a href="#">Timing Diagrams</a> section	1300		160		ns
$t_{(HDSTA)}$	Hold time after repeated START condition. After this period, the first clock is generated.		600		160		ns
$t_{(SUSTA)}$	Repeated START condition setup time		600		160		ns
$t_{(SUSTO)}$	STOP condition setup time		600		160		ns
$t_{(HDDAT)}$	Data hold time		4	900	4	120	ns
$t_{(SUDAT)}$	Data setup time		100		10		ns
$t_{(LOW)}$	SCL clock low period	V+, see the <a href="#">Timing Diagrams</a> section	1300		280		ns
$t_{(HIGH)}$	SCL clock high period	See the <a href="#">Timing Diagrams</a> section	600		60		ns
$t_{FD}$	Data fall time	See the <a href="#">Timing Diagrams</a> section	300		150		ns
$t_{RC}$	Clock rise time	See the <a href="#">Two-Wire Timing Diagrams</a> section	300		40		ns
		SCLK $\leq$ 100 kHz, see the <a href="#">Timing Diagrams</a> section	1000				
$t_{FC}$	Clock fall time	See the <a href="#">Two-Wire Timing Diagrams</a> section	300		40		ns

### 6.7 Typical Characteristics

at  $T_A = 25^\circ\text{C}$  and  $V_+ = 5\text{ V}$  (unless otherwise noted)

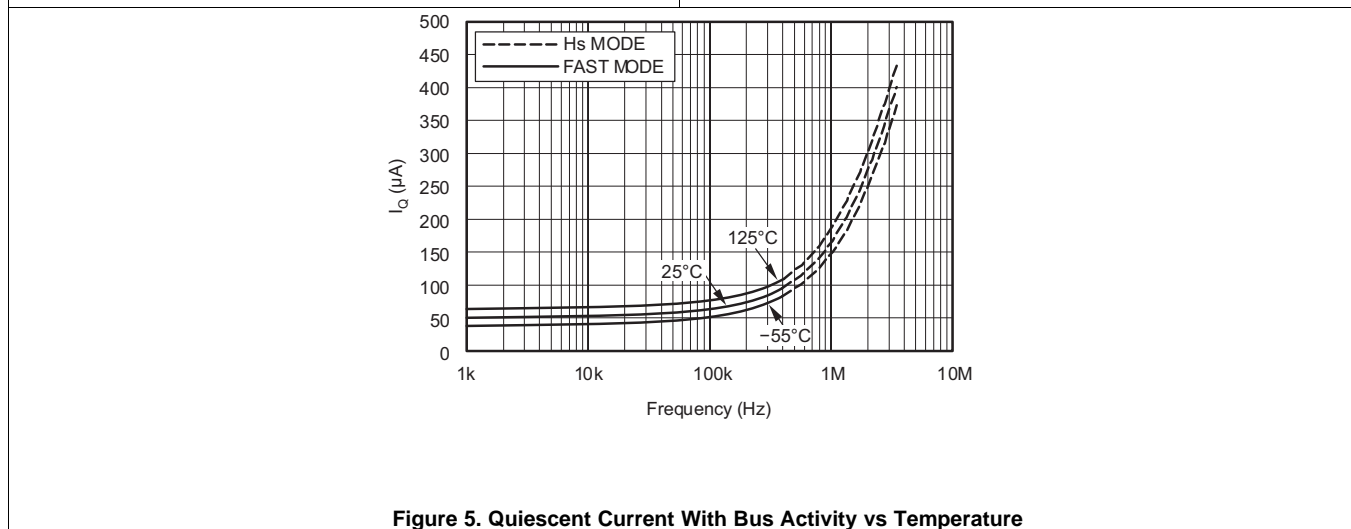
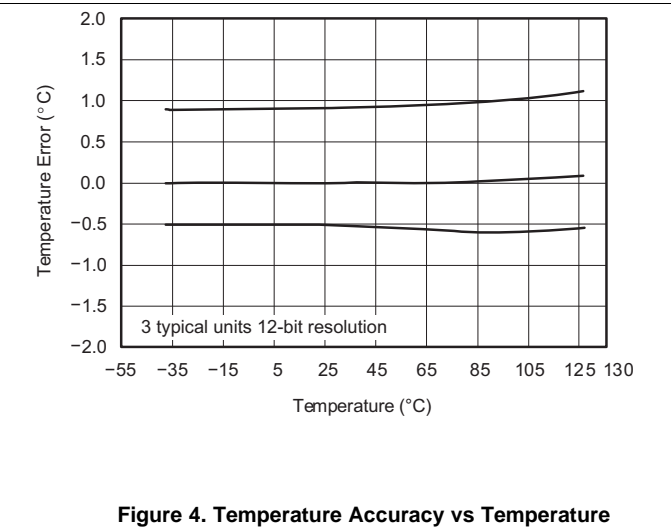
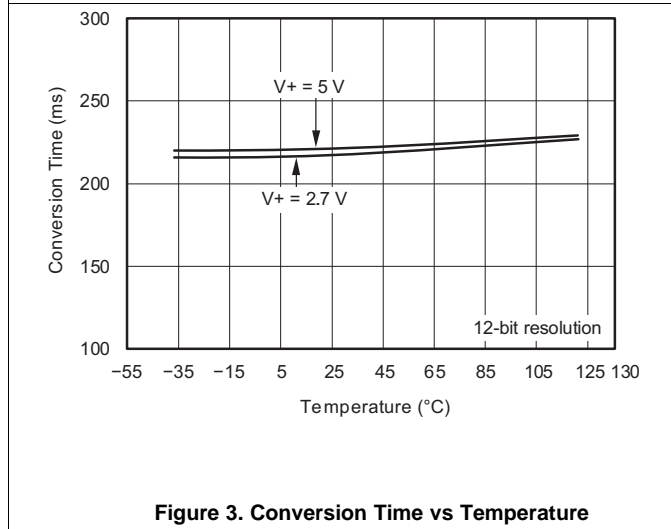
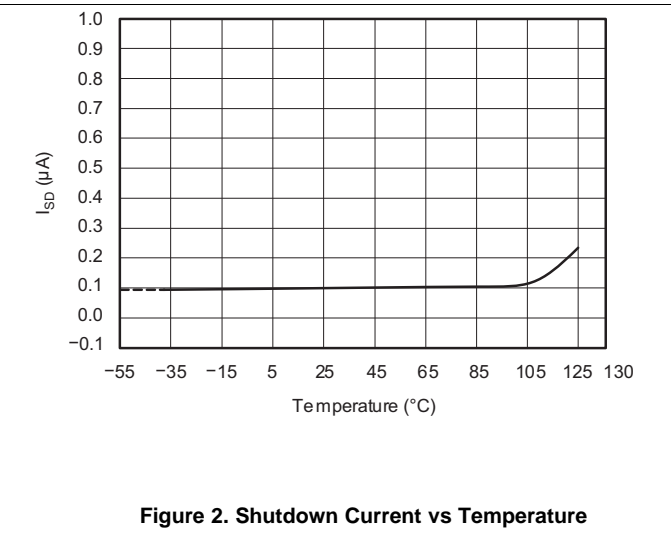
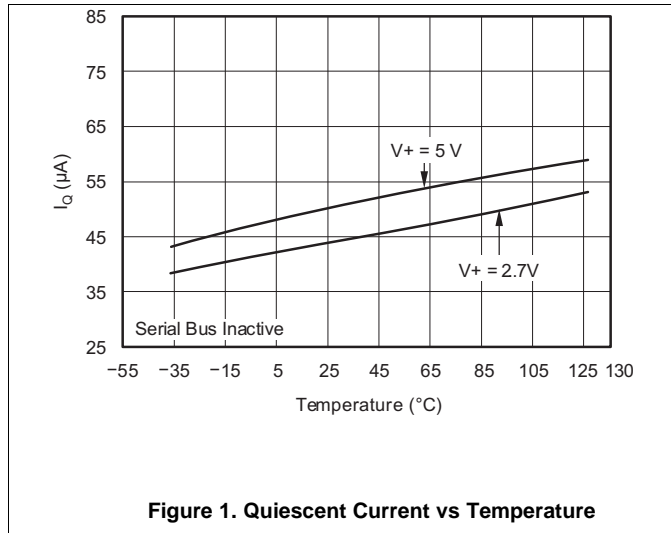

## 7 Detailed Description

### 7.1 Overview

The TMP175 and TMP75 devices are digital temperature sensors that are optimal for thermal management and thermal protection applications. The TMP175 and TMP75 are two-wire, SMBus, and I<sup>2</sup>C interface-compatible. The devices are specified over a temperature range of –40°C to +125°C. The [Functional Block Diagram](#) section shows an internal block diagram of TMP175 and TMP75 devices.

The temperature sensor in the TMP175 and TMP75 devices is the device itself. Thermal paths run through the package leads as well as the plastic package. The package leads provide the primary thermal path because of the lower thermal resistance of the metal.

### 7.2 Functional Block Diagram

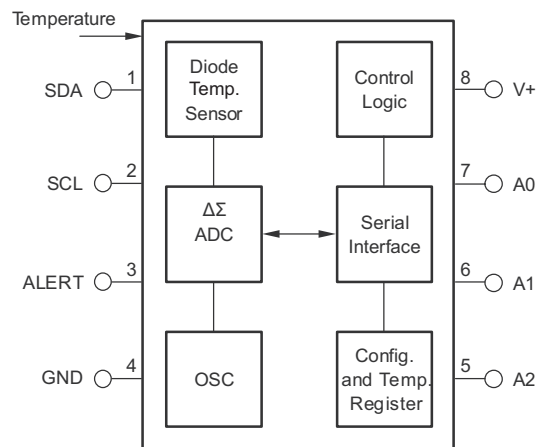

## 7.3 Feature Description

### 7.3.1 Digital Temperature Output

The digital output from each temperature measurement conversion is stored in the read-only Temperature register. The Temperature register of the TMP175 or TMP75 is a 12-bit read-only register that stores the output of the most recent conversion. Two bytes must be read to obtain data, and are listed in [Table 6](#) and [Table 7](#). The first 12 bits are used to indicate temperature with all remaining bits equal to zero. Data format for temperature is listed in [Table 1](#). Negative numbers are represented in binary twos complement format. Following power-up or reset, the Temperature register reads 0°C until the first conversion is complete.

The user can obtain 9, 10, 11, or 12 bits of resolution by addressing the Configuration register and setting the resolution bits accordingly. For 9-, 10-, or 11-bit resolution, the most significant bits (MSBs) in the Temperature register are used with the unused least significant bits (LSBs) set to zero.

**Table 1. Temperature Data Format**

TEMPERATURE (°C)	DIGITAL OUTPUT	
	BINARY	HEX
128	0111 1111 1111	7FF
127.9375	0111 1111 1111	7FF
100	0110 0100 0000	640
80	0101 0000 0000	500
75	0100 1011 0000	4B0
50	0011 0010 0000	320
25	0001 1001 0000	190
0.25	0000 0000 0100	004
0	0000 0000 0000	000
-0.25	1111 1111 1100	FFC
-25	1110 0111 0000	E70
-55	1100 1001 0000	C90

### 7.3.2 Serial Interface

The TMP175 and TMP75 operate only as slave devices on the SMBus, two-wire, and I<sup>2</sup>C interface-compatible bus. Connections to the bus are made through the open-drain I/O lines SDA and SCL. The SDA and SCL pins feature integrated spike suppression filters and Schmitt triggers to minimize the effects of input spikes and bus noise. The TMP175 and TMP75 support the transmission protocol for fast (up to 400 kHz) and high-speed (up to 2 MHz) modes. All data bytes are transmitted MSB first.

#### 7.3.2.1 Bus Overview

The device that initiates the transfer is called a *master*, and the devices controlled by the master are *slaves*. The bus must be controlled by a master device that generates the serial clock (SCL), controls the bus access, and generates the START and STOP conditions.

To address a specific device, a START condition is initiated, indicated by pulling the data line (SDA) from a high to low logic level when SCL is high. All slaves on the bus shift in the slave address byte, with the last bit indicating whether a read or write operation is intended. During the ninth clock pulse, the slave being addressed responds to the master by generating an Acknowledge and pulling SDA low.

Data transfer is then initiated and sent over eight clock pulses followed by an Acknowledge bit. During data transfer SDA must remain stable when SCL is high because any change in SDA when SCL is high is interpreted as a control signal.

When all data are transferred, the master generates a STOP condition indicated by pulling SDA from low to high when SCL is high.

### 7.3.2.2 Serial Bus Address

To communicate with the TMP175 and TMP75, the master must first address slave devices through a slave address byte. The slave address byte consists of seven address bits, and a direction bit indicating the intent of executing a read or write operation.

The TMP175 features three address pins to allow up to 27 devices to be addressed on a single bus interface. [Table 2](#) describes the pin logic levels used to properly connect up to 27 devices. A 1 indicates the pin is connected to the supply (VCC); a 0 indicates the pin is connected to GND; *float* indicates the pin is left unconnected. The state of pins A0, A1, and A2 is sampled on every bus communication and must be set prior to any activity on the interface.

The TMP75 features three address pins allowing up to eight devices to be connected per bus. Pin logic levels are described in [Table 3](#). The address pins of the TMP175 and TMP75 are read after reset, at start of communication, or in response to a two-wire address acquire request. After the state of the pins are read, the address is latched to minimize power dissipation associated with detection.

**Table 2. Address Pins and Slave Addresses for the TMP175**

A2	A1	A0	SLAVE ADDRESS
0	0	0	1001000
0	0	1	1001001
0	1	0	1001010
0	1	1	1001011
1	0	0	1001100
1	0	1	1001101
1	1	0	1001110
1	1	1	1001111
Float	0	0	1110000
Float	0	Float	1110001
Float	0	1	1110010
Float	1	0	1110011
Float	1	Float	1110100
Float	1	1	1110101
Float	Float	0	1110110
Float	Float	1	1110111
0	Float	0	0101000
0	Float	1	0101001
1	Float	0	0101010
1	Float	1	0101011
0	0	Float	0101100
0	1	Float	0101101
1	0	Float	0101110
1	1	Float	0101111
0	Float	Float	0110101
1	Float	Float	0110110
Float	Float	Float	0110111

**Table 3. Address Pins and Slave Addresses for the TMP75**

A2	A1	A0	SLAVE ADDRESS
0	0	0	1001000
0	0	1	1001001
0	1	0	1001010
0	1	1	1001011
1	0	0	1001100
1	0	1	1001101
1	1	0	1001110
1	1	1	1001111

### 7.3.2.3 Writing and Reading to the TMP175 and TMP75

Accessing a particular register on the TMP175 and TMP75 devices is accomplished by writing the appropriate value to the Pointer register. The value for the Pointer register is the first byte transferred after the slave address byte with the R/W bit low. Every write operation to the TMP175 and TMP75 requires a value for the Pointer register (see [Figure 7](#)).

When reading from the TMP175 and TMP75 devices, the last value stored in the Pointer register by a write operation is used to determine which register is read by a read operation. To change the register pointer for a read operation, a new value must be written to the Pointer register. This action is accomplished by issuing a slave address byte with the R/W bit low, followed by the Pointer register byte. No additional data are required. The master can then generate a START condition and send the slave address byte with the R/W bit high to initiate the read command. See [Figure 9](#) for details of this sequence. If repeated reads from the same register are desired, the Pointer register bytes do not have to be continually sent because the TMP175 and TMP75 remember the Pointer register value until the value is changed by the next write operation.

Register bytes are sent MSB first, followed by the LSB.

### 7.3.2.4 Slave Mode Operations

The TMP175 and TMP75 can operate as a slave receiver or slave transmitter.

#### 7.3.2.4.1 Slave Receiver Mode

The first byte transmitted by the master is the slave address, with the  $\overline{R/W}$  bit low. The TMP175 or TMP75 then acknowledges reception of a valid address. The next byte transmitted by the master is the Pointer register. The TMP175 or TMP75 then acknowledges reception of the Pointer register byte. The next byte or bytes are written to the register addressed by the Pointer register. The TMP175 and TMP75 acknowledge reception of each data byte. The master can terminate data transfer by generating a START or STOP condition.

#### 7.3.2.4.2 Slave Transmitter Mode

The first byte is transmitted by the master and is the slave address, with the  $\overline{R/W}$  bit high. The slave acknowledges reception of a valid slave address. The next byte is transmitted by the slave and is the most significant byte of the register indicated by the Pointer register. The master acknowledges reception of the data byte. The next byte transmitted by the slave is the least significant byte. The master acknowledges reception of the data byte. The master can terminate data transfer by generating a Not-Acknowledge on reception of any data byte, or generating a START or STOP condition.

### 7.3.2.5 SMBus Alert Function

The TMP175 and TMP75 support the SMBus Alert function. When the TMP75 and TMP175 are operating in interrupt mode ( $TM = 1$ ), the ALERT pin of the TMP75 or TMP175 can be connected as an SMBus Alert signal. When a master senses that an ALERT condition is present on the ALERT line, the master sends an SMBus Alert command (00011001) on the bus. If the ALERT pin of the TMP75 or TMP175 is active, the devices acknowledge the SMBus Alert command and respond by returning its slave address on the SDA line. The eighth bit (LSB) of the slave address byte indicates if the temperature exceeding  $T_{HIGH}$  or falling below  $T_{LOW}$  caused the ALERT condition. This bit is high if the temperature is greater than or equal to  $T_{HIGH}$ . This bit is low if the temperature is less than  $T_{LOW}$ . See [Figure 10](#) for details of this sequence.

If multiple devices on the bus respond to the SMBus Alert command, arbitration during the slave address portion of the SMBus Alert command determine which device clears its ALERT status. If the TMP75 or TMP175 wins the arbitration, its ALERT pin becomes inactive at the completion of the SMBus Alert command. If the TMP75 or TMP175 loses the arbitration, its ALERT pin remains active.

### 7.3.2.6 General Call

The TMP175 and TMP75 respond to a two-wire general call address (0000000) if the eighth bit is 0. The device acknowledges the general call address and responds to commands in the second byte. If the second byte is 00000100, the TMP175 and TMP75 latch the status of their address pins, but do not reset. If the second byte is 00000110, the TMP175 and TMP75 latch the status of their address pins and reset their internal registers to their power-up values.

### 7.3.2.7 High-Speed Mode

In order for the two-wire bus to operate at frequencies above 400 kHz, the master device must issue an Hs-mode master code (00001XXX) as the first byte after a START condition to switch the bus to high-speed operation. The TMP175 and TMP75 devices do not acknowledge this byte, but do switch their input filters on SDA and SCL and their output filters on SDA to operate in Hs-mode, allowing transfers at up to 2 MHz. After the Hs-mode master code is issued, the master transmits a two-wire slave address to initiate a data transfer operation. The bus continues to operate in Hs-mode until a STOP condition occurs on the bus. Upon receiving the STOP condition, the TMP175 and TMP75 switch the input and output filter back to fast-mode operation.

### 7.3.2.8 Time-out Function

The TMP175 resets the serial interface if either SCL or SDA is held low for 54 ms (typical) between a START and STOP condition. The TMP175 releases the bus if it is pulled low and waits for a START condition. To avoid activating the time-out function, a communication speed of at least 1 kHz must be maintained for the SCL operating frequency.

## 7.3.3 Timing Diagrams

The TMP175 and TMP75 devices are two-wire, SMBus, and I<sup>2</sup>C interface-compatible. [Figure 6](#) to [Figure 10](#) describe the various operations on the TMP175. The following list provides bus definitions. Parameters for [Figure 6](#) are defined in the [Timing Requirements](#).

**Bus Idle:** Both SDA and SCL lines remain high.

**Start Data Transfer:** A change in the state of the SDA line, from high to low when the SCL line is high defines a START condition. Each data transfer is initiated with a START condition.

**Stop Data Transfer:** A change in the state of the SDA line from low to high when the SCL line is high defines a STOP condition. Each data transfer is terminated with a repeated START or STOP condition.

**Data Transfer:** The number of data bytes transferred between a START and a STOP condition is not limited and is determined by the master device. The receiver acknowledges the transfer of data.

**Acknowledge:** Each receiving device, when addressed, is obliged to generate an Acknowledge bit. A device that acknowledges must pull down the SDA line during the Acknowledge clock pulse in such a way that the SDA line is stable low during the high period of the Acknowledge clock pulse. Setup and hold times must be taken into account. On a master receive, the termination of the data transfer can be signaled by the master generating a Not-Acknowledge on the last byte that is transmitted by the slave.

7.3.4 Two-Wire Timing Diagrams

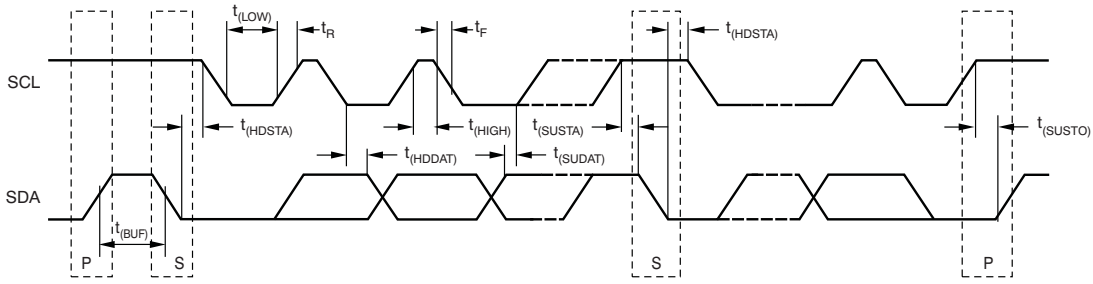

Figure 6. Two-Wire Timing Diagram

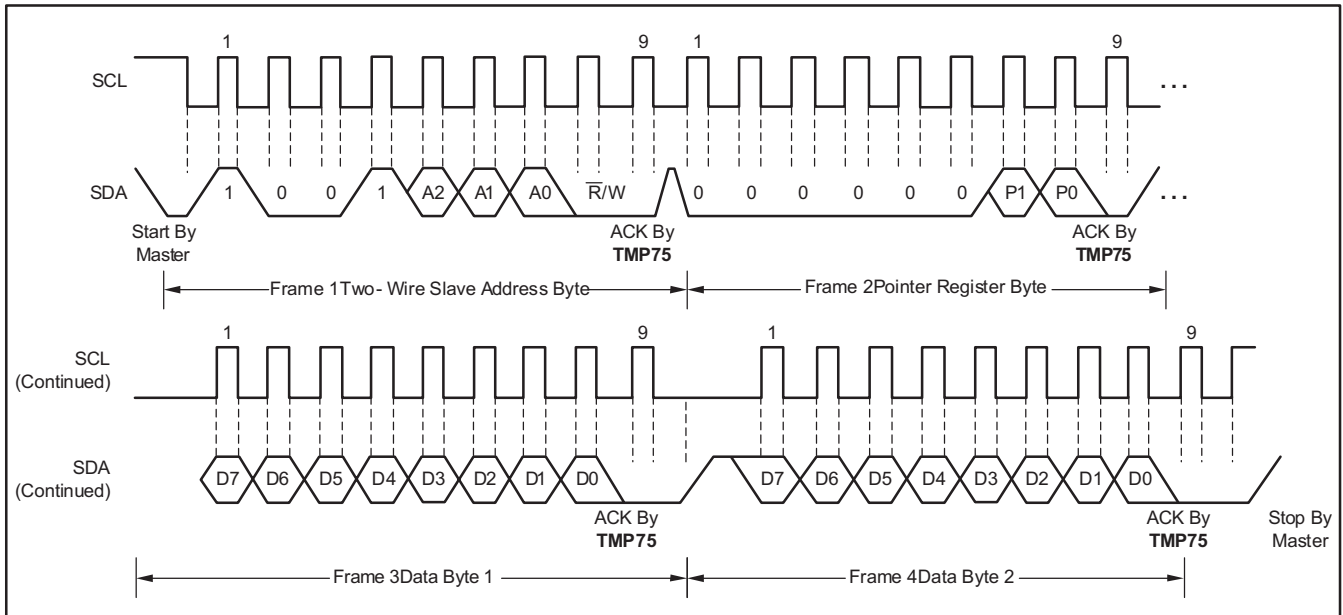

Figure 7. Two-Wire Timing Diagram for the TMP75 Write Word Format

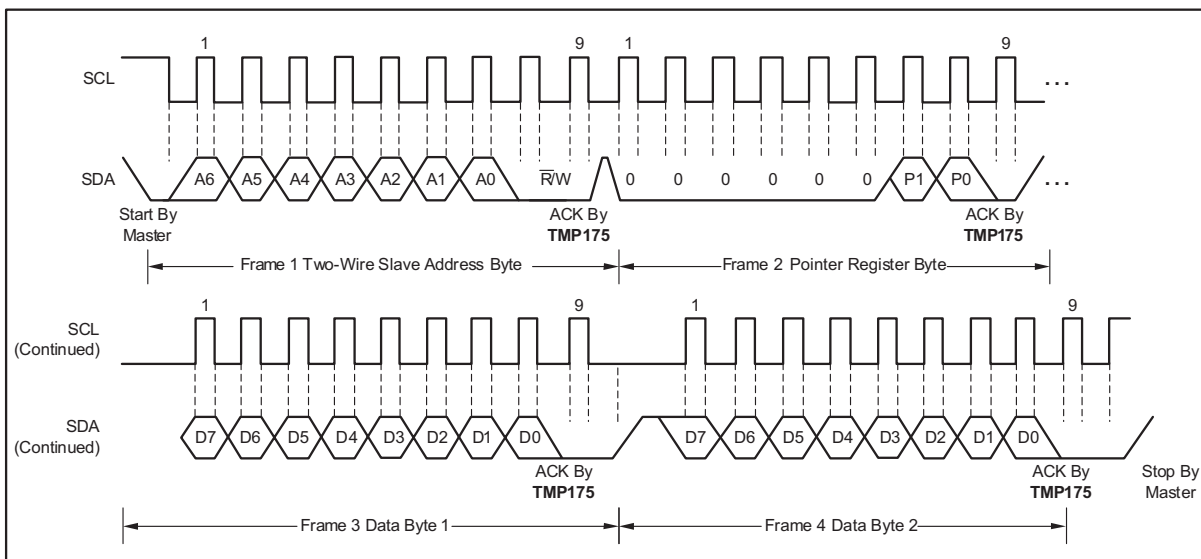

Figure 8. Two-Wire Timing Diagram for the TMP175 Write Word Format

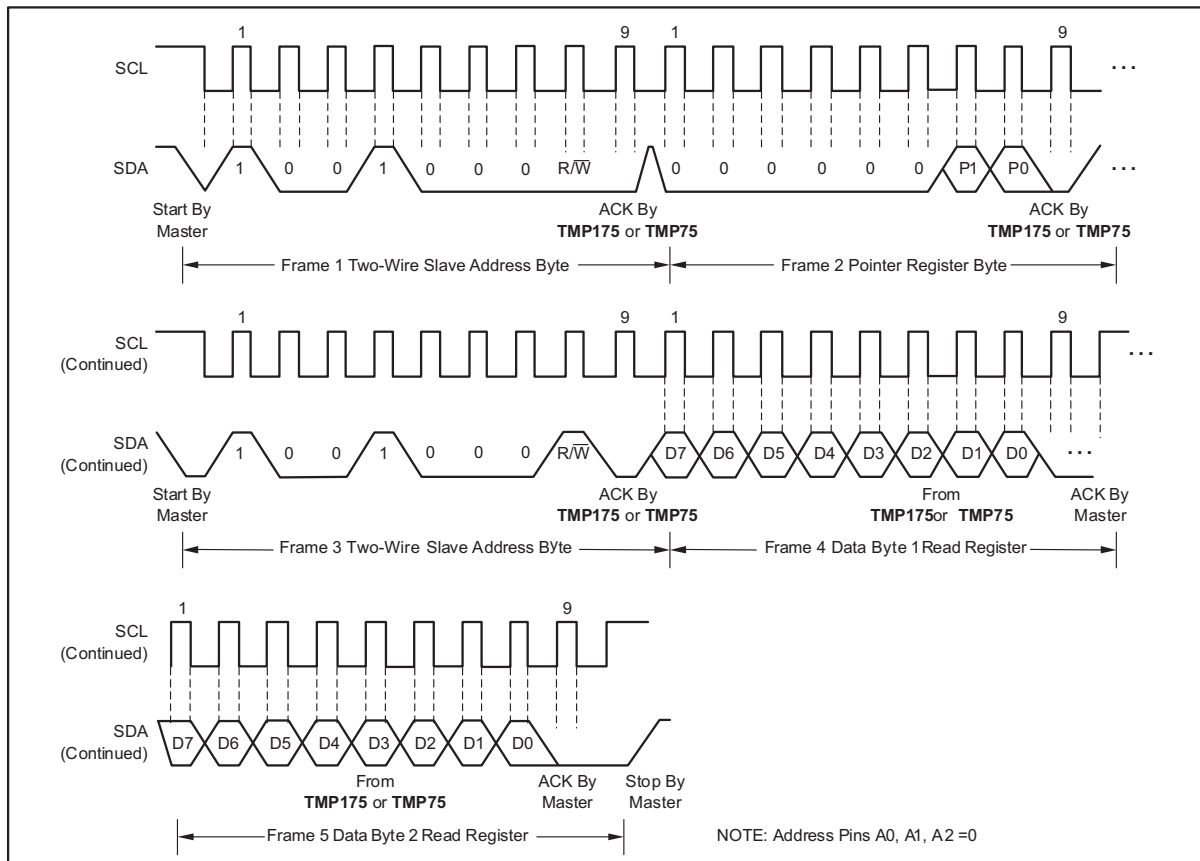

Figure 9. Two-Wire Timing Diagram for Read Word Format

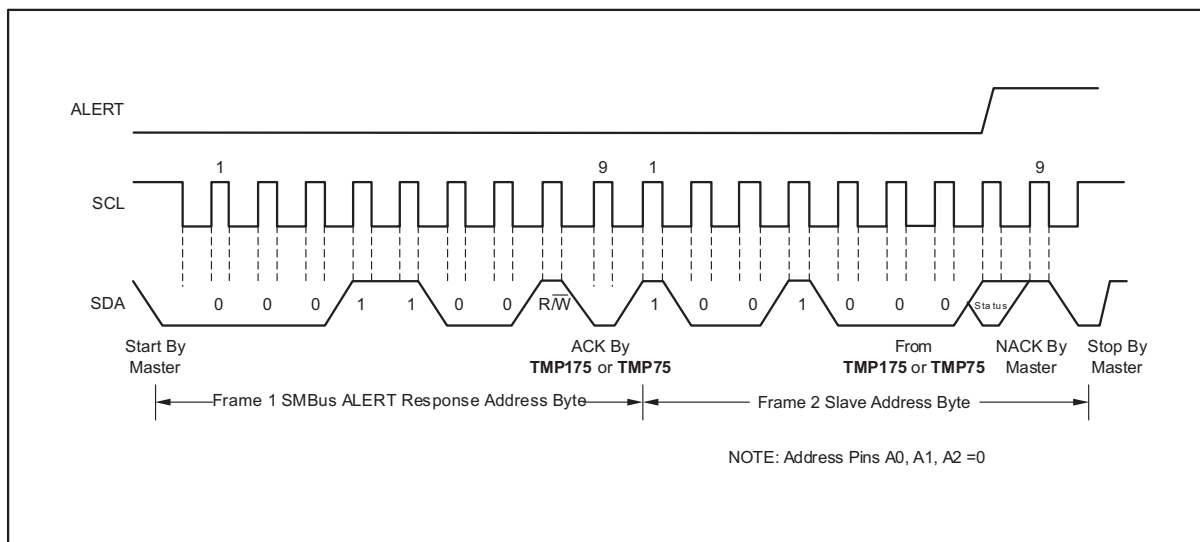

Figure 10. Timing Diagram for SMBus ALERT

## 7.4 Device Functional Modes

### 7.4.1 Shutdown Mode (SD)

The shutdown mode of the TMP175 and TMP75 devices lets the user save maximum power by shutting down all device circuitry other than the serial interface, which reduces current consumption to typically less than 0.1  $\mu$ A. Shutdown mode is enabled when the SD bit is 1; the device shuts down when the current conversion is completed. When SD is equal to 0, the device maintains a continuous conversion state.

### 7.4.2 One-shot (OS)

The TMP175 and TMP75 feature a one-shot temperature measurement mode. When the device is in shutdown mode, writing 1 to the OS bit starts a single temperature conversion. The device returns to the shutdown state at the completion of the single conversion. This feature is useful to reduce power consumption in the TMP175 and TMP75 when continuous temperature monitoring is not required. When the configuration register is read, the OS always reads zero.

### 7.4.3 Thermostat Mode (TM)

The thermostat mode bit of the TMP175 and TMP75 indicates to the device whether to operate in comparator mode (TM = 0) or interrupt mode (TM = 1). For more information on comparator and interrupt modes, see the [High and Low Limit Registers](#) section.

#### 7.4.3.1 Comparator Mode (TM = 0)

In comparator mode (TM = 0), the ALERT pin is activated when the temperature equals or exceeds the value in the  $T_{(HIGH)}$  register and remains active until the temperature falls below the value in the  $T_{(LOW)}$  register. For more information on the comparator mode, see the [High and Low Limit Registers](#) section.

#### 7.4.3.2 Interrupt Mode (TM = 1)

In interrupt mode (TM = 1), the ALERT pin is activated when the temperature exceeds  $T_{(HIGH)}$  or goes below  $T_{(LOW)}$  registers. The ALERT pin is cleared when the host controller reads the temperature register. For more information on the interrupt mode, see the [High and Low Limit Registers](#) section.

## 7.5 Programming

### 7.5.1 Pointer Register

Figure 11 shows the internal register structure of the TMP175 and TMP75. The 8-bit Pointer register of the devices is used to address a given data register. The Pointer register uses the two LSBs to identify which of the data registers must respond to a read or write command. Table 4 identifies the bits of the Pointer register byte. Table 5 describes the pointer address of the registers available in the TMP175 and TMP75. Power-up reset value of P1/P0 is 00.

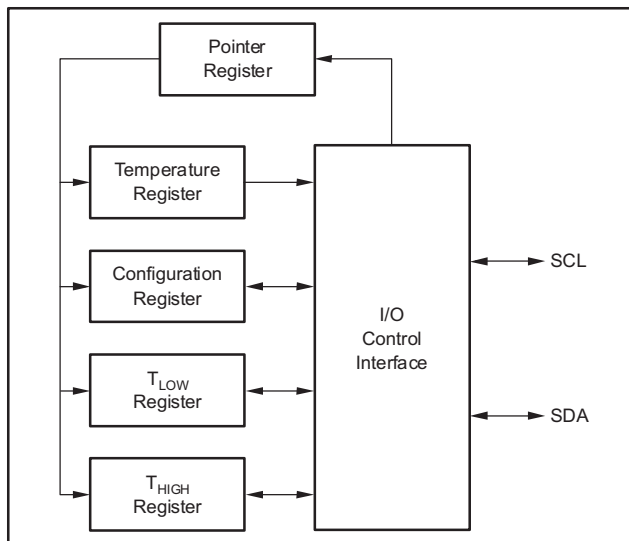

Figure 11. Internal Register Structure of the TMP175 and TMP75

#### 7.5.1.1 Pointer Register Byte (pointer = N/A) [reset = 00h]

Table 4. Pointer Register Byte

P7	P6	P5	P4	P3	P2	P1	P0
0	0	0	0	0	0	Register Bits	

#### 7.5.1.2 Pointer Addresses of the TMP175

Table 5. Pointer Addresses of the TMP175 and TMP75

P1	P0	TYPE	REGISTER
0	0	R only, default	Temperature register
0	1	R/W	Configuration register
1	0	R/W	T <sub>LOW</sub> register
1	1	R/W	T <sub>HIGH</sub> register

## 7.5.2 Temperature Register

The Temperature register of the TMP175 or TMP75 is a 12-bit, read-only register that stores the output of the most recent conversion. Two bytes must be read to obtain data, and are described in [Table 6](#) and [Table 7](#). Byte 1 is the most significant byte, followed by byte 2, the least significant byte. The first 12 bits are used to indicate temperature, with all remaining bits equal to zero. The least significant byte does not have to be read if that information is not needed. Following power-up or reset value, the Temperature register reads 0°C until the first conversion is complete.

**Table 6. Byte 1 of the Temperature Register**

D7	D6	D5	D4	D3	D2	D1	D0
T11	T10	T9	T8	T7	T6	T5	T4

**Table 7. Byte 2 of the Temperature Register**

D7	D6	D5	D4	D3	D2	D1	D0
T3	T2	T1	T0	0	0	0	0

## 7.5.3 Configuration Register

The Configuration register is an 8-bit read/write register used to store bits that control the operational modes of the temperature sensor. Read and write operations are performed MSB first. The format of the Configuration register for the TMP175 and TMP75 is shown in [Table 8](#), followed by a breakdown of the register bits. The power-up or reset value of the Configuration register are all bits equal to 0.

**Table 8. Configuration Register Format**

BYTE	D7	D6	D5	D4	D3	D2	D1	D0
1	OS	R1	R0	F1	F0	POL	TM	SD

### 7.5.3.1 Shutdown Mode (SD)

The shutdown mode of the TMP175 and TMP75 allows the user to save maximum power by shutting down all device circuitry other than the serial interface, which reduces current consumption to typically less than 0.1  $\mu$ A. Shutdown mode is enabled when the SD bit is 1; the device shuts down when the current conversion is completed. When SD is equal to 0, the device maintains a continuous conversion state.

### 7.5.3.2 Thermostat Mode (TM)

The thermostat mode bit of the TMP175 and TMP75 indicates to the device whether to operate in comparator mode (TM = 0) or interrupt mode (TM = 1). For more information on comparator and interrupt modes, see the [High and Low Limit Registers](#) section.

### 7.5.3.3 Polarity (POL)

The polarity bit of the TMP175 lets the user adjust the polarity of the ALERT pin output. If the POL bit is set to 0 (default), the ALERT pin becomes active low. When POL bit is set to 1, the ALERT pin becomes active high and the state of the ALERT pin is inverted. The operation of the ALERT pin in various modes is illustrated in Figure 12.

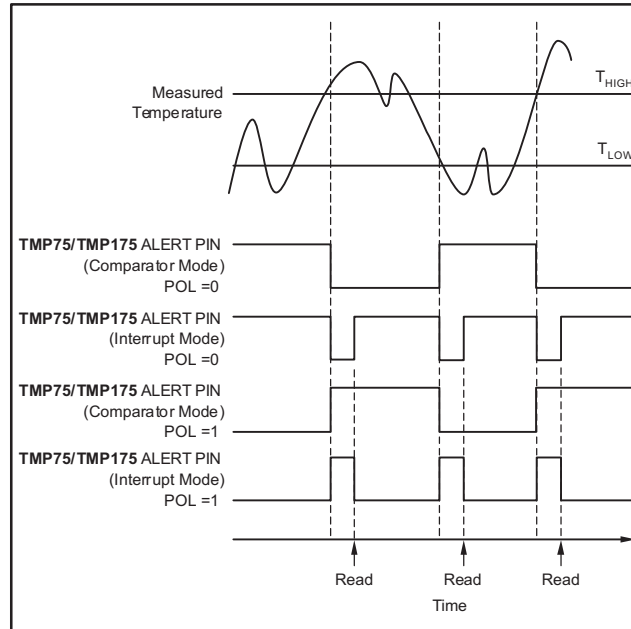

**Figure 12. Output Transfer Function Diagrams**

### 7.5.3.4 Fault Queue (F1/F0)

A fault condition is defined as when the measured temperature exceeds the user-defined limits set in the  $T_{HIGH}$  and  $T_{LOW}$  registers. Additionally, the number of fault conditions required to generate an alert may be programmed using the fault queue. The fault queue is provided to prevent a false alert as a result of environmental noise. The fault queue requires consecutive fault measurements in order to trigger the alert function. Table 9 defines the number of measured faults that can be programmed to trigger an alert condition in the device. For  $T_{HIGH}$  and  $T_{LOW}$  register format and byte order, see the [High and Low Limit Registers](#) section.

**Table 9. Fault Settings of the TMP175 and TMP75**

F1	F0	CONSECUTIVE FAULTS
0	0	1
0	1	2
1	0	4
1	1	6

### 7.5.3.5 Converter Resolution (R1/R0)

The converter resolution bits control the resolution of the internal ADC converter. This control allows the user to maximize efficiency by programming for higher resolution or faster conversion time. [Table 10](#) identifies the resolution bits and the relationship between resolution and conversion time.

**Table 10. Resolution of the TMP175 and TMP75**

R1	R0	RESOLUTION	CONVERSION TIME (Typical)
0	0	9 bits (0.5°C)	27.5 ms
0	1	10 bits (0.25°C)	55 ms
1	0	11 bits (0.125°C)	110 ms
1	1	12 bits (0.0625°C)	220 ms

### 7.5.3.6 One-Shot (OS)

The TMP175 and TMP75 feature a one-shot temperature measurement mode. When the device is in shutdown mode, writing a 1 to the OS bit starts a single temperature conversion. The device returns to the shutdown state at the completion of the single conversion. This feature is useful to reduce power consumption in the TMP175 and TMP75 when continuous temperature monitoring is not required. When the configuration register is read, the OS always reads zero.

### 7.5.4 High and Low Limit Registers

In comparator mode (TM = 0), the ALERT pin of the TMP175 and TMP75 becomes active when the temperature equals or exceeds the value in  $T_{HIGH}$  and generates a consecutive number of faults according to fault bits F1 and F0. The ALERT pin remains active until the temperature falls below the indicated  $T_{LOW}$  value for the same number of faults.

In interrupt mode (TM = 1), the ALERT pin becomes active when the temperature equals or exceeds  $T_{HIGH}$  for a consecutive number of fault conditions. The ALERT pin remains active until a read operation of any register occurs, or the device successfully responds to the SMBus Alert response address. The ALERT pin is also cleared if the device is placed in shutdown mode. When the ALERT pin is cleared, it only become active again by the temperature falling below  $T_{LOW}$ . When the temperature falls below  $T_{LOW}$ , the ALERT pin becomes active and remains active until cleared by a read operation of any register or a successful response to the SMBus Alert response address. When the ALERT pin is cleared, the above cycle repeats, with the ALERT pin becoming active when the temperature equals or exceeds  $T_{HIGH}$ . The ALERT pin can also be cleared by resetting the device with the general call reset command. This action also clears the state of the internal registers in the device by returning the device to comparator mode (TM = 0).

Both operational modes are represented in [Figure 12](#). [Table 11](#), [Table 12](#), [Table 13](#), and [Table 14](#) describe the format for the  $T_{HIGH}$  and  $T_{LOW}$  registers. The most significant byte is sent first, followed by the least significant byte. Power-up reset values for  $T_{HIGH}$  and  $T_{LOW}$  are:

$$T_{HIGH} = 80^{\circ}\text{C} \text{ and } T_{LOW} = 75^{\circ}\text{C}$$

The format of the data for  $T_{HIGH}$  and  $T_{LOW}$  is the same as for the Temperature register.

**Table 11. Byte 1 of the  $T_{HIGH}$  Register**

D7	D6	D5	D4	D3	D2	D1	D0
H11	H10	H9	H8	H7	H6	H5	H4

**Table 12. Byte 2 of the  $T_{HIGH}$  Register**

D7	D6	D5	D4	D3	D2	D1	D0
H3	H2	H1	H0	0	0	0	0

**Table 13. Byte 1 of the  $T_{LOW}$  Register**

BYTE	D7	D6	D5	D4	D3	D2	D1	D0
1	L11	L10	L9	L8	L7	L6	L5	L4

**Table 14. Byte 2 of the  $T_{LOW}$  Register**

D7	D6	D5	D4	D3	D2	D1	D0
L3	L2	L1	L0	0	0	0	0

All 12 bits for the Temperature,  $T_{HIGH}$ , and  $T_{LOW}$  registers are used in the comparisons for the ALERT function for all converter resolutions. The three LSBs in  $T_{HIGH}$  and  $T_{LOW}$  can affect the ALERT output even if the converter is configured for 9-bit resolution.

## 8 Application and Implementation

### NOTE

Information in the following applications sections is not part of the TI component specification, and TI does not warrant its accuracy or completeness. TI's customers are responsible for determining suitability of components for their purposes. Customers should validate and test their design implementation to confirm system functionality.

### 8.1 Application Information

The TMP175 and TMP75 devices are used to measure the PCB temperature of the location it is mounted. The TMP175 and TMP75 feature SMBus, two-wire, and I<sup>2</sup>C interface compatibility, with the TMP175 allowing up to 27 devices on one bus and the TMP75 allowing up to eight devices on one bus. The TMP175 and TMP75 both feature an SMBus Alert function. The TMP175 and TMP75 require no external components for operation except for pullup resistors on SCL, SDA, and ALERT, although a 0.1- $\mu$ F bypass capacitor is recommended.

The sensing device of the TMP175 and TMP75 devices is the device itself. Thermal paths run through the package leads as well as the plastic package. The lower thermal resistance of metal causes the leads to provide the primary thermal path.

### 8.2 Typical Application

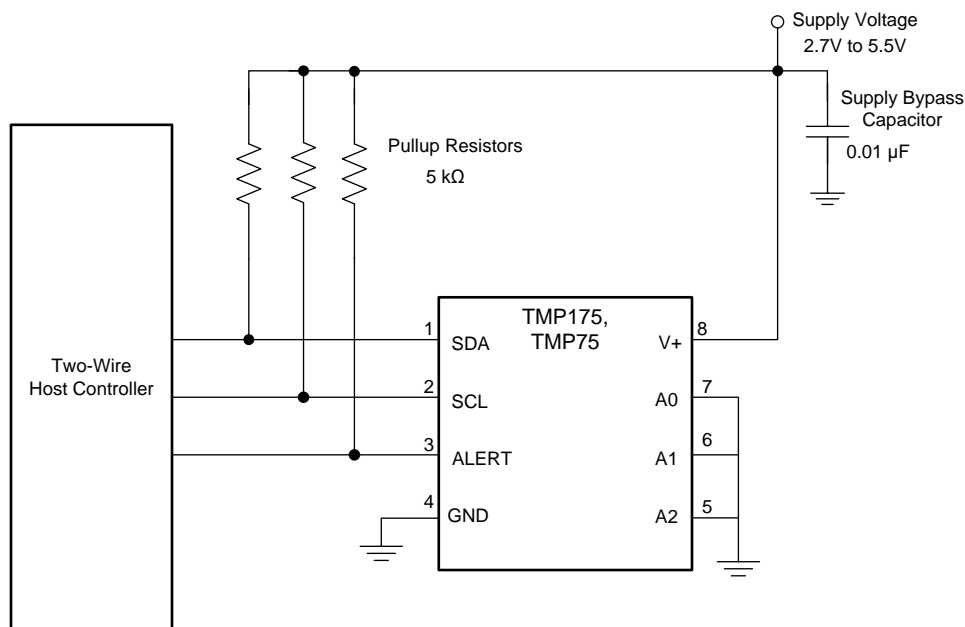

Figure 13. Typical Connections of the TMP175 and TMP75

#### 8.2.1 Design Requirements

The TMP175 and TMP75 devices requires pullup resistors on the SCL, SDA, and ALERT pins. The recommended value for the pullup resistor is 5 k $\Omega$ . In some applications the pullup resistor can be lower or higher than 5 k $\Omega$  but must not exceed 3 mA of current on the SCL and SDA pins, and must not exceed 4 mA on the ALERT pin. A 0.1- $\mu$ F bypass capacitor is recommended, as shown in Figure 13. The SCL, SDA, and ALERT lines can be pulled up to a supply that is equal to or higher than  $V_S$  through the pullup resistors. For TMP175, to configure one of 27 different addresses on the bus, connect A0, A1, and A2 to either the GND or V+ pin, or float. Float indicates the pin is left unconnected. For the TMP75, to configure one of eight different addresses on the bus, connect A0, A1, and A2 to either the GND or V+ pin.

## Typical Application (continued)

### 8.2.2 Detailed Design Procedure

Place the TMP175 and TMP75 devices in close proximity to the heat source that must be monitored, with a proper layout for good thermal coupling. This placement ensures that temperature changes are captured within the shortest possible time interval. To maintain accuracy in applications that require air or surface temperature measurement, take care to isolate the package and leads from ambient air temperature. A thermally-conductive adhesive is helpful in achieving accurate surface temperature measurement.

### 8.2.3 Application Curve

Figure 14 shows the step response of the TMP175 and TMP75 devices to a submersion in an oil bath of 100°C from room temperature (27°C). The time-constant, or the time for the output to reach 63% of the input step, is 1.5 s. The time-constant result depends on the printed-circuit-board (PCB) that the TMPx175 devices are mounted. For this test, the TMP175 and TMP75 devices were soldered to a two-layer PCB that measured 0.375 inch x 0.437 inch.

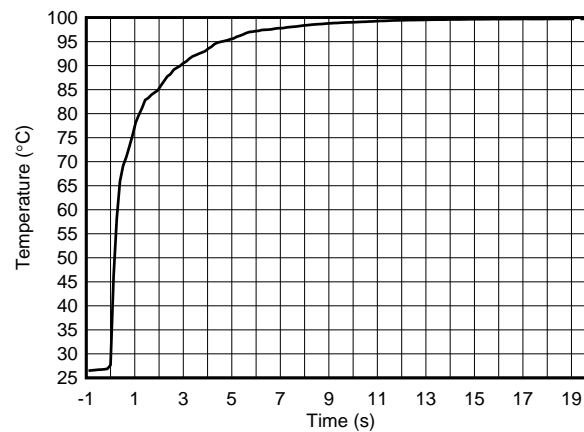

**Figure 14. Temperature Step Response**

## 9 Power Supply Recommendations

The TMP175 and TMP75 devices operate with a power supply in the range of 2.7 V to 5.5 V. A power-supply bypass capacitor is required for stability; place this capacitor as close as possible to the supply and ground pins of the device. A typical value for this supply bypass capacitor is 0.01  $\mu\text{F}$ . Applications with noisy or high-impedance power supplies can require additional decoupling capacitors to reject power-supply noise.

## 10 Layout

### 10.1 Layout Guidelines

Place the power-supply bypass capacitor as close as possible to the supply and ground pins. The recommended value of this bypass capacitor is 0.01  $\mu\text{F}$ . Additional decoupling capacitance can be added to compensate for noisy or high-impedance power supplies. Pull up the open-drain output pins SDA, SCL, and ALERT through 5-k $\Omega$  pullup resistors.

### 10.2 Layout Example

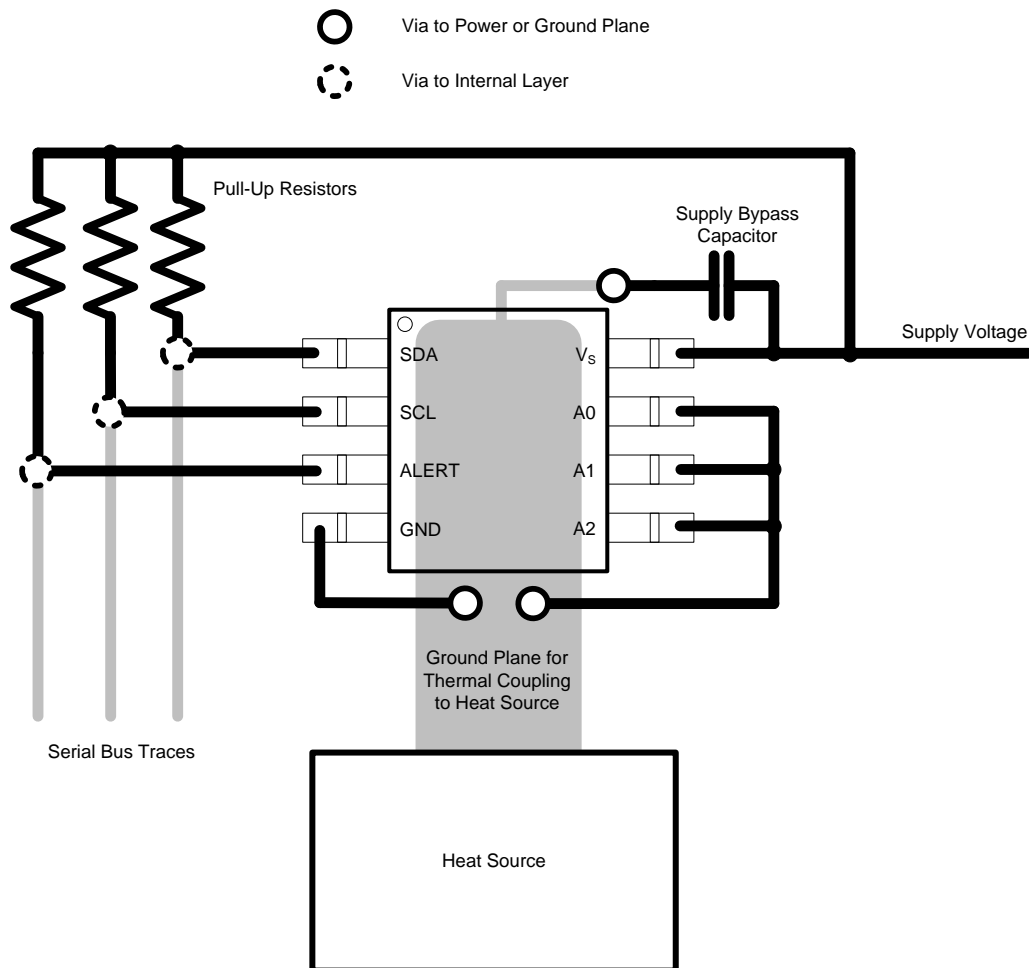

Figure 15. Layout Example

## 11 Device and Documentation Support

### 11.1 Related Links

The table below lists quick access links. Categories include technical documents, support and community resources, tools and software, and quick access to sample or buy.

**Table 15. Related Links**

PARTS	PRODUCT FOLDER	SAMPLE & BUY	TECHNICAL DOCUMENTS	TOOLS & SOFTWARE	SUPPORT & COMMUNITY
TMP175	<a href="#">Click here</a>	<a href="#">Click here</a>	<a href="#">Click here</a>	<a href="#">Click here</a>	<a href="#">Click here</a>
TMP75	<a href="#">Click here</a>	<a href="#">Click here</a>	<a href="#">Click here</a>	<a href="#">Click here</a>	<a href="#">Click here</a>

### 11.2 Community Resources

The following links connect to TI community resources. Linked contents are provided "AS IS" by the respective contributors. They do not constitute TI specifications and do not necessarily reflect TI's views; see TI's [Terms of Use](#).

**TI E2E™ Online Community** *TI's Engineer-to-Engineer (E2E) Community*. Created to foster collaboration among engineers. At [e2e.ti.com](http://e2e.ti.com), you can ask questions, share knowledge, explore ideas and help solve problems with fellow engineers.

**Design Support** *TI's Design Support* Quickly find helpful E2E forums along with design support tools and contact information for technical support.

### 11.3 Trademarks

E2E is a trademark of Texas Instruments.

SMBus is a trademark of Intel Corporation.

All other trademarks are the property of their respective owners.

### 11.4 Electrostatic Discharge Caution



These devices have limited built-in ESD protection. The leads should be shorted together or the device placed in conductive foam during storage or handling to prevent electrostatic damage to the MOS gates.

### 11.5 Glossary

[SLYZ022](#) — *TI Glossary*.

This glossary lists and explains terms, acronyms, and definitions.

## 12 Mechanical, Packaging, and Orderable Information

The following pages include mechanical, packaging, and orderable information. This information is the most current data available for the designated devices. This data is subject to change without notice and revision of this document. For browser-based versions of this data sheet, refer to the left-hand navigation.

**PACKAGING INFORMATION**

Orderable Device	Status (1)	Package Type	Package Drawing	Pins	Package Qty	Eco Plan (2)	Lead/Ball Finish (6)	MSL Peak Temp (3)	Op Temp (°C)	Device Marking (4/5)	Samples
TMP175AID	ACTIVE	SOIC	D	8	75	Green (RoHS & no Sb/Br)	CU NIPDAU	Level-2-250C-1 YEAR	-40 to 125	TMP175	<a href="#">Samples</a>
TMP175AIDGKR	ACTIVE	VSSOP	DGK	8	2500	Green (RoHS & no Sb/Br)	CU NIPDAU   CU NIPDAUAG	Level-2-260C-1 YEAR	-40 to 125	DABQ	<a href="#">Samples</a>
TMP175AIDGKT	ACTIVE	VSSOP	DGK	8	250	Green (RoHS & no Sb/Br)	CU NIPDAU   CU NIPDAUAG	Level-2-260C-1 YEAR	-40 to 125	DABQ	<a href="#">Samples</a>
TMP175AIDGKTG4	ACTIVE	VSSOP	DGK	8	250	Green (RoHS & no Sb/Br)	CU NIPDAUAG	Level-2-260C-1 YEAR	-40 to 125	DABQ	<a href="#">Samples</a>
TMP175AIDR	ACTIVE	SOIC	D	8	2500	Green (RoHS & no Sb/Br)	CU NIPDAU	Level-2-260C-1 YEAR	-40 to 125	TMP175	<a href="#">Samples</a>
TMP75AID	ACTIVE	SOIC	D	8	75	Green (RoHS & no Sb/Br)	CU NIPDAU   Call TI	Level-1-260C-UNLIM	-40 to 125	TMP75	<a href="#">Samples</a>
TMP75AIDG4	ACTIVE	SOIC	D	8	75	Green (RoHS & no Sb/Br)	Call TI	Level-1-260C-UNLIM	-40 to 125	TMP75	<a href="#">Samples</a>
TMP75AIDGKR	ACTIVE	VSSOP	DGK	8	2500	Green (RoHS & no Sb/Br)	CU NIPDAU   CU NIPDAUAG	Level-2-260C-1 YEAR	-40 to 125	T127	<a href="#">Samples</a>
TMP75AIDGKRG4	ACTIVE	VSSOP	DGK	8	2500	Green (RoHS & no Sb/Br)	CU NIPDAUAG	Level-2-260C-1 YEAR	-40 to 125	T127	<a href="#">Samples</a>
TMP75AIDGKT	ACTIVE	VSSOP	DGK	8	250	Green (RoHS & no Sb/Br)	CU NIPDAU   CU NIPDAUAG	Level-2-260C-1 YEAR	-40 to 125	T127	<a href="#">Samples</a>
TMP75AIDGKTG4	ACTIVE	VSSOP	DGK	8	250	Green (RoHS & no Sb/Br)	CU NIPDAUAG	Level-2-260C-1 YEAR	-40 to 125	T127	<a href="#">Samples</a>
TMP75AIDR	ACTIVE	SOIC	D	8	2500	Green (RoHS & no Sb/Br)	CU NIPDAU   Call TI	Level-1-260C-UNLIM	-40 to 125	TMP75	<a href="#">Samples</a>
TMP75AIDRG4	ACTIVE	SOIC	D	8	2500	Green (RoHS & no Sb/Br)	Call TI	Level-1-260C-UNLIM	-40 to 125	TMP75	<a href="#">Samples</a>

(1) The marketing status values are defined as follows:

**ACTIVE:** Product device recommended for new designs.

**LIFEBUY:** TI has announced that the device will be discontinued, and a lifetime-buy period is in effect.

**NRND:** Not recommended for new designs. Device is in production to support existing customers, but TI does not recommend using this part in a new design.

**PREVIEW:** Device has been announced but is not in production. Samples may or may not be available.

**OBSELETE:** TI has discontinued the production of the device.

(2) **RoHS:** TI defines "RoHS" to mean semiconductor products that are compliant with the current EU RoHS requirements for all 10 RoHS substances, including the requirement that RoHS substance do not exceed 0.1% by weight in homogeneous materials. Where designed to be soldered at high temperatures, "RoHS" products are suitable for use in specified lead-free processes. TI may reference these types of products as "Pb-Free".

**RoHS Exempt:** TI defines "RoHS Exempt" to mean products that contain lead but are compliant with EU RoHS pursuant to a specific EU RoHS exemption.

**Green:** TI defines "Green" to mean the content of Chlorine (Cl) and Bromine (Br) based flame retardants meet JS709B low halogen requirements of <=1000ppm threshold. Antimony trioxide based flame retardants must also meet the <=1000ppm threshold requirement.

(3) **MSL, Peak Temp.** - The Moisture Sensitivity Level rating according to the JEDEC industry standard classifications, and peak solder temperature.

(4) There may be additional marking, which relates to the logo, the lot trace code information, or the environmental category on the device.

(5) Multiple Device Markings will be inside parentheses. Only one Device Marking contained in parentheses and separated by a "~" will appear on a device. If a line is indented then it is a continuation of the previous line and the two combined represent the entire Device Marking for that device.

(6) **Lead/Ball Finish** - Orderable Devices may have multiple material finish options. Finish options are separated by a vertical ruled line. Lead/Ball Finish values may wrap to two lines if the finish value exceeds the maximum column width.

**Important Information and Disclaimer:**The information provided on this page represents TI's knowledge and belief as of the date that it is provided. TI bases its knowledge and belief on information provided by third parties, and makes no representation or warranty as to the accuracy of such information. Efforts are underway to better integrate information from third parties. TI has taken and continues to take reasonable steps to provide representative and accurate information but may not have conducted destructive testing or chemical analysis on incoming materials and chemicals. TI and TI suppliers consider certain information to be proprietary, and thus CAS numbers and other limited information may not be available for release.

In no event shall TI's liability arising out of such information exceed the total purchase price of the TI part(s) at issue in this document sold by TI to Customer on an annual basis.

**OTHER QUALIFIED VERSIONS OF TMP175, TMP75 :**

- Automotive: [TMP175-Q1](#), [TMP75-Q1](#)

NOTE: Qualified Version Definitions:

- Automotive - Q100 devices qualified for high-reliability automotive applications targeting zero defects

## TAPE AND REEL INFORMATION

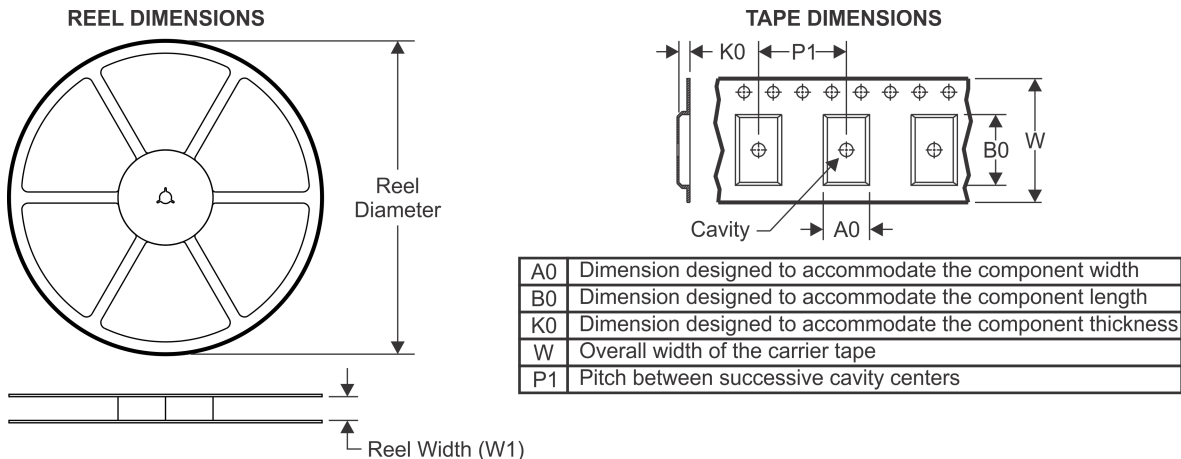

### QUADRANT ASSIGNMENTS FOR PIN 1 ORIENTATION IN TAPE



\*All dimensions are nominal

Device	Package Type	Package Drawing	Pins	SPQ	Reel Diameter (mm)	Reel Width W1 (mm)	A0 (mm)	B0 (mm)	K0 (mm)	P1 (mm)	W (mm)	Pin1 Quadrant
TMP175AIDGKR	VSSOP	DGK	8	2500	330.0	12.4	5.3	3.4	1.4	8.0	12.0	Q1
TMP175AIDGKR	VSSOP	DGK	8	2500	330.0	12.4	5.3	3.3	1.3	8.0	12.0	Q1
TMP175AIDGKT	VSSOP	DGK	8	250	330.0	12.4	5.3	3.4	1.4	8.0	12.0	Q1
TMP175AIDGKT	VSSOP	DGK	8	250	180.0	12.4	5.3	3.3	1.3	8.0	12.0	Q1
TMP175AIDR	SOIC	D	8	2500	330.0	12.4	6.4	5.2	2.1	8.0	12.0	Q1
TMP75AIDGKR	VSSOP	DGK	8	2500	330.0	12.4	5.3	3.4	1.4	8.0	12.0	Q1
TMP75AIDGKT	VSSOP	DGK	8	250	330.0	12.4	5.3	3.4	1.4	8.0	12.0	Q1
TMP75AIDR	SOIC	D	8	2500	330.0	12.4	6.4	5.2	2.1	8.0	12.0	Q1

**TAPE AND REEL BOX DIMENSIONS**

\*All dimensions are nominal

Device	Package Type	Package Drawing	Pins	SPQ	Length (mm)	Width (mm)	Height (mm)
TMP175AIDGKR	VSSOP	DGK	8	2500	366.0	364.0	50.0
TMP175AIDGKR	VSSOP	DGK	8	2500	370.0	355.0	55.0
TMP175AIDGKT	VSSOP	DGK	8	250	366.0	364.0	50.0
TMP175AIDGKT	VSSOP	DGK	8	250	195.0	200.0	45.0
TMP175AIDR	SOIC	D	8	2500	367.0	367.0	35.0
TMP75AIDGKR	VSSOP	DGK	8	2500	366.0	364.0	50.0
TMP75AIDGKT	VSSOP	DGK	8	250	366.0	364.0	50.0
TMP75AIDR	SOIC	D	8	2500	367.0	367.0	35.0



# EXAMPLE BOARD LAYOUT

D0008A

SOIC - 1.75 mm max height

SMALL OUTLINE INTEGRATED CIRCUIT



LAND PATTERN EXAMPLE  
 EXPOSED METAL SHOWN  
 SCALE:8X



SOLDER MASK DETAILS

4214825/C 02/2019

NOTES: (continued)

- 6. Publication IPC-7351 may have alternate designs.
- 7. Solder mask tolerances between and around signal pads can vary based on board fabrication site.

# EXAMPLE STENCIL DESIGN

D0008A

SOIC - 1.75 mm max height

SMALL OUTLINE INTEGRATED CIRCUIT



SOLDER PASTE EXAMPLE  
BASED ON .005 INCH [0.125 MM] THICK STENCIL  
SCALE:8X

4214825/C 02/2019

NOTES: (continued)

8. Laser cutting apertures with trapezoidal walls and rounded corners may offer better paste release. IPC-7525 may have alternate design recommendations.
9. Board assembly site may have different recommendations for stencil design.





- NOTES:
- A. All linear dimensions are in millimeters.
  - B. This drawing is subject to change without notice.
  - C. Publication IPC-7351 is recommended for alternate designs.
  - D. Laser cutting apertures with trapezoidal walls and also rounding corners will offer better paste release. Customers should contact their board assembly site for stencil design recommendations. Refer to IPC-7525 for other stencil recommendations.
  - E. Customers should contact their board fabrication site for solder mask tolerances between and around signal pads.

## IMPORTANT NOTICE AND DISCLAIMER

TI PROVIDES TECHNICAL AND RELIABILITY DATA (INCLUDING DATASHEETS), DESIGN RESOURCES (INCLUDING REFERENCE DESIGNS), APPLICATION OR OTHER DESIGN ADVICE, WEB TOOLS, SAFETY INFORMATION, AND OTHER RESOURCES "AS IS" AND WITH ALL FAULTS, AND DISCLAIMS ALL WARRANTIES, EXPRESS AND IMPLIED, INCLUDING WITHOUT LIMITATION ANY IMPLIED WARRANTIES OF MERCHANTABILITY, FITNESS FOR A PARTICULAR PURPOSE OR NON-INFRINGEMENT OF THIRD PARTY INTELLECTUAL PROPERTY RIGHTS.

These resources are intended for skilled developers designing with TI products. You are solely responsible for (1) selecting the appropriate TI products for your application, (2) designing, validating and testing your application, and (3) ensuring your application meets applicable standards, and any other safety, security, or other requirements. These resources are subject to change without notice. TI grants you permission to use these resources only for development of an application that uses the TI products described in the resource. Other reproduction and display of these resources is prohibited. No license is granted to any other TI intellectual property right or to any third party intellectual property right. TI disclaims responsibility for, and you will fully indemnify TI and its representatives against, any claims, damages, costs, losses, and liabilities arising out of your use of these resources.

TI's products are provided subject to TI's Terms of Sale ([www.ti.com/legal/termsofsale.html](http://www.ti.com/legal/termsofsale.html)) or other applicable terms available either on [ti.com](http://ti.com) or provided in conjunction with such TI products. TI's provision of these resources does not expand or otherwise alter TI's applicable warranties or warranty disclaimers for TI products.

Mailing Address: Texas Instruments, Post Office Box 655303, Dallas, Texas 75265  
Copyright © 2019, Texas Instruments Incorporated

## Looking for pricing, stock, or lifecycle information?

Click below to explore more details on WIN SOURCE:

 [View TMP75AIDGKTG4 on WIN SOURCE](#)

 [Texas Instruments](#) Information

## Optimize Your Supply Chain with WIN SOURCE Solutions

-  Global Sourcing Solution
-  Obsolete Management
-  Cost Control Management
-  Shortage Management
-  Alternative Solution
-  Excess Inventory Management