



**THE DATASHEET OF  
DS90UH925QSQE/NOPB**



# DS90UH925Q-Q1 720p 24-bit Color FPD-Link III Serializer with HDCP

## 1 Features

- Integrated HDCP Cipher Engine with On-chip Key Storage
- Bidirectional Control Interface Channel Interface with I2C Compatible Serial Control Bus
- Supports High Definition (720p) Digital Video Format
- RGB888 + VS, HS, DE and I2S Audio Supported
- 5 to 85 MHz PCLK Supported
- Single 3.3V Operation with 1.8 V or 3.3 V Compatible LVCMOS I/O Interface
- AC-coupled STP Interconnect up to 10 meters
- Parallel LVCMOS Video Inputs
- DC-balanced & Scrambled Data with Embedded Clock
- HDCP Content Protected
- Supports HDCP Repeater Application
- Internal Pattern Generation
- Low Power Modes Minimize Power Dissipation
- Automotive Grade Product: AEC-Q100 Grade 2 Qualified
- > 8k V HBM and ISO 10605 ESD rating
- Backward Compatible Modes

## 2 Applications

- Automotive Display for Navigation
- Rear Seat Entertainment Systems

## 3 Description

The DS90UH925Q-Q1 serializer, in conjunction with the DS90UH926Q-Q1 deserializer, provides a solution for secure distribution of content-protected digital video within automotive entertainment systems. This chipset translates a parallel RGB Video Interface into a single pair high-speed serialized interface. The digital video data is protected using the industry standard HDCP copy protection scheme. The serial bus scheme, FPD-Link III, supports video and audio data transmission and full duplex control including I2C communication over a single differential link. Consolidation of video data and control over a single differential pair reduces the interconnect size and weight, while also eliminating skew issues and simplifying system design.

The DS90UH925Q-Q1 serializer embeds the clock, content protects the data payload, and level shifts the signals to high-speed low voltage differential signaling. Up to 24 RGB data bits are serialized along with three video control signals and up to two I2S data inputs.

EMI is minimized by the use of low voltage differential signaling, data scrambling and randomization and spread spectrum clocking compatibility.

The HDCP cipher engine is implemented in the serializer and deserializer. HDCP keys are stored in on-chip memory.

### Device Information<sup>(1)</sup>

PART NUMBER	PACKAGE	BODY SIZE
DS90UH925Q-Q1	WQFN (48)	7.00 mm x 7.00 mm

(1) For all available packages, see the orderable addendum at the end of the datasheet.

### Simplified Schematic

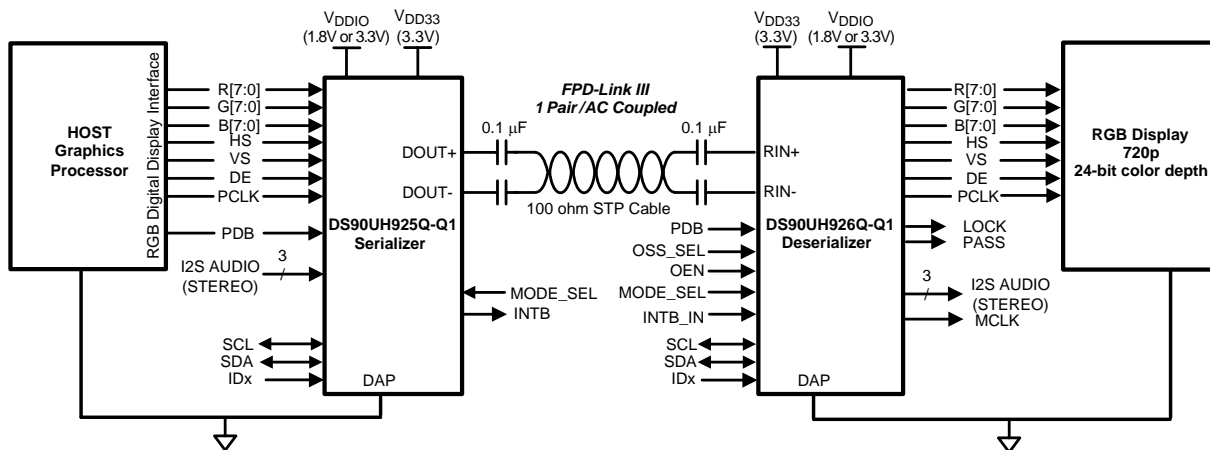

## Table of Contents

<b>1 Features</b> .....	<b>1</b>	7.3 Feature Description .....	<b>14</b>
<b>2 Applications</b> .....	<b>1</b>	7.4 Device Functional Modes .....	<b>21</b>
<b>3 Description</b> .....	<b>1</b>	7.5 Programming .....	<b>25</b>
<b>4 Revision History</b> .....	<b>2</b>	7.6 Register Maps .....	<b>27</b>
<b>5 Pin Configuration and Functions</b> .....	<b>3</b>	<b>8 Applications and Implementation</b> .....	<b>42</b>
<b>6 Specifications</b> .....	<b>6</b>	8.1 Application Information .....	<b>42</b>
6.1 Absolute Maximum Ratings .....	<b>6</b>	8.2 Typical Application .....	<b>43</b>
6.2 Handling Ratings .....	<b>6</b>	<b>9 Power Supply Recommendations</b> .....	<b>45</b>
6.3 Recommended Operating Conditions .....	<b>6</b>	9.1 Power Up Requirements and PDB Pin .....	<b>45</b>
6.4 Thermal Information .....	<b>7</b>	9.2 CML Interconnect Guidelines .....	<b>45</b>
6.5 DC Electrical Characteristics .....	<b>7</b>	<b>10 Layout</b> .....	<b>46</b>
6.6 AC Electrical Characteristics .....	<b>8</b>	10.1 Layout Guidelines .....	<b>46</b>
6.7 DC and AC Serial Control Bus Characteristics .....	<b>9</b>	10.2 Layout Example .....	<b>47</b>
6.8 Recommended Timing for Serial Control Bus .....	<b>9</b>	<b>11 Device and Documentation Support</b> .....	<b>49</b>
6.9 Switching Characteristics .....	<b>12</b>	11.1 Documentation Support .....	<b>49</b>
6.10 Typical Characteristics .....	<b>13</b>	11.2 Trademarks .....	<b>49</b>
<b>7 Detailed Description</b> .....	<b>14</b>	11.3 Electrostatic Discharge Caution .....	<b>49</b>
7.1 Overview .....	<b>14</b>	11.4 Glossary .....	<b>49</b>
7.2 Functional Block Diagram .....	<b>14</b>	<b>12 Mechanical, Packaging, and Orderable Information</b> .....	<b>49</b>

## 4 Revision History

### Changes from Revision I (April 2013) to Revision J

**Page**

• Added, updated, or renamed the following sections: Device Information Table, Pin Configuration and Functions, Application and Implementation; Power Supply Recommendations; Layout; Device and Documentation Support; Mechanical, Packaging, and Ordering Information .....	<b>1</b>
• Fixed typo for GPIO configuration .....	<b>17</b>
• Removed two MODE_SEL modes: I2S Channel B, and Backward Compatible .....	<b>22</b>
• Removed IDx addresses 0x22, 0x24, 0x2C, 0x2E, 0x30, 0x32, 0x34 .....	<b>25</b>
• Changed suggested resistor values for IDx addresses 0x1E, 0x20, 0x26, 0x28, 0x2A .....	<b>25</b>

### Changes from Revision H (October 2010) to Revision I

**Page**

• Changed layout from National Data Sheet style to TI format .....	<b>1</b>
--	----------

## 5 Pin Configuration and Functions

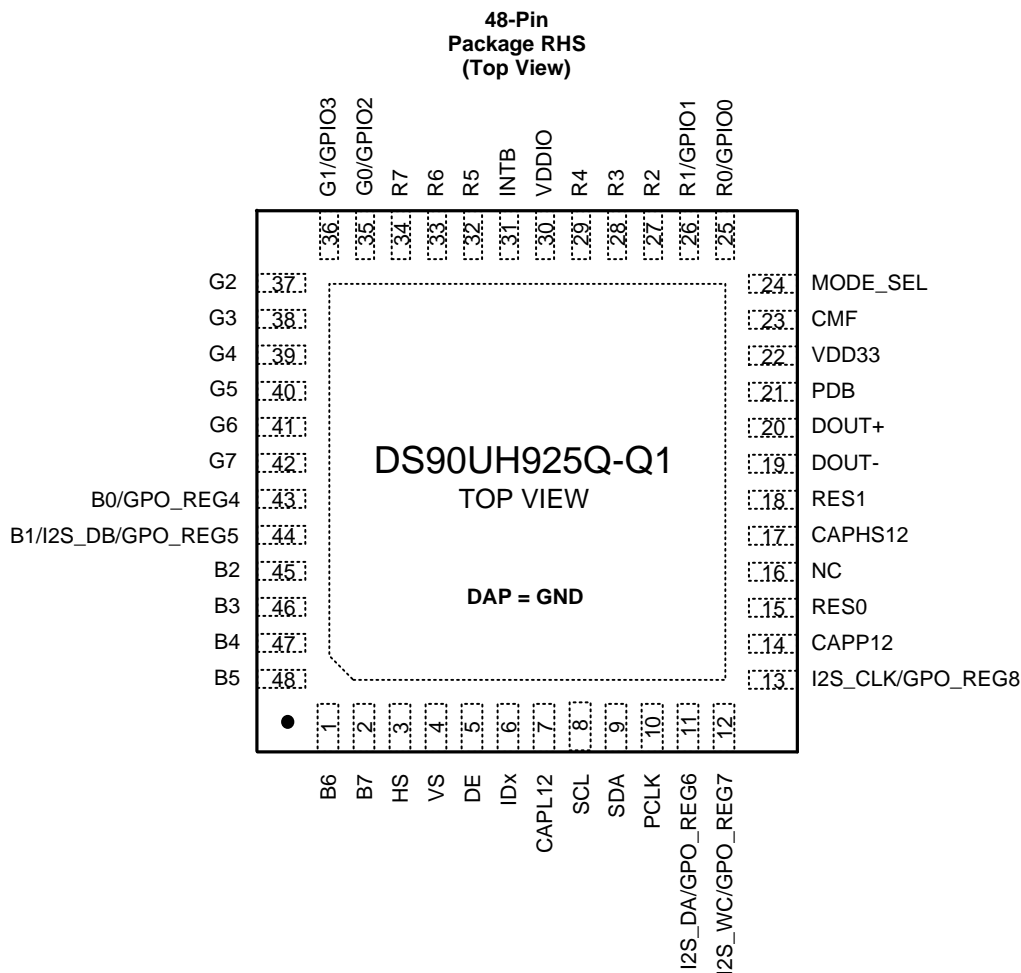

### Pin Functions

PIN		I/O, TYPE	DESCRIPTION
NAME	NUMBER		
<b>LVCOS PARALLEL INTERFACE</b>			
R[7:0]	34, 33, 32, 29, 28, 27, 26, 25	I, LVCMOS w/ pull down	RED Parallel Interface Data Input Pins Leave open if unused. R0 can optionally be used as GPIO0 and R1 can optionally be used as GPIO1.
G[7:0]	42, 41, 40, 39, 38, 37, 36, 35	I, LVCMOS w/ pull down	GREEN Parallel Interface Data Input Pins Leave open if unused. G0 can optionally be used as GPIO2 and G1 can optionally be used as GPIO3.
B[7:0]	2, 1, 48, 47, 46, 45, 44, 43	I, LVCOS w/ pull down	BLUE Parallel Interface Data Input Pins Leave open if unused B0 can optionally be used as GPO_REG4 and B1 can optionally be used as GPO_REG5.
HS	3	I, LVCMOS w/ pull down	Horizontal Sync Input Pin Video control signal pulse width must be 3 PCLKs or longer to be transmitted when the Control Signal Filter is enabled. There is no restriction on the minimum transition pulse when the Control Signal Filter is disabled. The signal is limited to 2 transitions per 130 PCLKs. See <a href="#">Table 6</a> .
VS	4	I, LVCMOS w/ pull down	Vertical Sync Input Pin Video control signal is limited to 1 transition per 130 PCLKs. Thus, the minimum pulse width is 130 PCLKs.

**Pin Functions (continued)**

PIN		I/O, TYPE	DESCRIPTION
NAME	NUMBER		
DE	5	I, LVCMOS w/ pull down	Data Enable Input Pin Video control signal pulse width must be 3 PCLKs or longer to be transmitted when the Control Signal Filter is enabled. There is no restriction on the minimum transition pulse when the Control Signal Filter is disabled. The signal is limited to 2 transitions per 130 PCLKs. See <a href="#">Table 6</a> .
PCLK	10	I, LVCMOS w/ pull down	Pixel Clock Input Pin. Strobe edge set by RFB configuration register. See <a href="#">Table 6</a> .
I2S_CLK, I2S_WC, I2S_DA	13, 12, 11	I, LVCMOS w/ pull down	Digital Audio Interface Data Input Pins Leave open if unused. I2S_CLK can optionally be used as GPO_REG8, I2S_WC can optionally be used as GPO_REG7, and I2S_DA can optionally be used as GPO_REG6.
<b>OPTIONAL PARALLEL INTERFACE</b>			
I2S_DB	44	I, LVCMOS w/ pull down	Second Channel Digital Audio Interface Data Input pin at 18-bit color mode and set by MODE_SEL pin or configuration register Leave open if unused. I2S_DB can optionally be used as B1 or GPO_REG5.
GPIO[3:0]	36, 35, 26, 25	I/O, LVCMOS w/ pull down	General Purpose IOs. Available only in 18-bit color mode, and set by MODE_SEL pin or configuration register. See <a href="#">Table 6</a> . Leave open if unused Shared with G1, G0, R1 and R0.
GPO_REG[ 8:4]	13, 12, 11, 44, 43	O, LVCMOS w/ pull down	General Purpose Outputs and set by configuration register. See <a href="#">Table 6</a> . Share with I2S_CLK, I2S_WC, I2S_DA, I2S_DB or B1, B0.
<b>CONTROL</b>			
PDB	21	I, LVCMOS w/ pull-down	Power-down Mode Input Pin PDB = H, device is enabled (normal operation) Refer to "Power Up Requirements and PDB Pin" in the Applications Information Section. PDB = L, device is powered down. When the device is in the powered down state, the Driver Outputs are both HIGH, the PLL is shutdown, and IDD is minimized. Control Registers are <b>RESET</b> .
MODE_SEL	24	I, Analog	Device Configuration Select. See <a href="#">Table 4</a> .
<b>I2C</b>			
IDx	6	I, Analog	I2C Serial Control Bus Device ID Address Select External pull-up to $V_{DD33}$ is required under all conditions, DO NOT FLOAT. Connect to external pull-up and pull-down resistor to create a voltage divider. See <a href="#">Figure 19</a> .
SCL	8	I/O, LVCMOS Open Drain	I2C Clock Input / Output Interface Must have an external pull-up to $V_{DD33}$ , DO NOT FLOAT. Recommended pull-up: 4.7k $\Omega$ .
SDA	9	I/O, LVCMOS Open Drain	I2C Data Input / Output Interface Must have an external pull-up to $V_{DD33}$ , DO NOT FLOAT. Recommended pull-up: 4.7k $\Omega$ .

**Pin Functions (continued)**

PIN		I/O, TYPE	DESCRIPTION
NAME	NUMBER		
<b>STATUS</b>			
INTB	31	O, LVCMOS Open Drain	HDCP Interrupt INTB = H, normal INTB = L, Interrupt request Recommended pull-up: 4.7kΩ to V <sub>DDIO</sub>
<b>FPD-Link III SERIAL INTERFACE</b>			
DOUT+	20	O, LVDS	True Output The output must be AC-coupled with a 0.1μF capacitor.
DOUT-	19	O, LVDS	Inverting Output The output must be AC-coupled with a 0.1μF capacitor.
CMF	23	Analog	Common Mode Filter. Connect 0.1μF to GND
<b>POWER<sup>(1)</sup> and GROUND</b>			
V <sub>DD33</sub>	22	Power	Power to on-chip regulator <b>3.0 V - 3.6 V</b> . Requires 4.7 uF to GND
V <sub>DDIO</sub>	30	Power	LVCMOS I/O Power <b>1.8 V ±5% OR 3.0 V - 3.6 V</b> . Requires 4.7 uF to GND
GND	DAP	Ground	DAP is the large metal contact at the bottom side, located at the center of the WQFN package. <b>Connect to the ground plane (GND)</b> with at least 9 vias.
<b>REGULATOR CAPACITOR</b>			
CAPHS12, CAPP12	17, 14	CAP	Decoupling capacitor connection for on-chip regulator. Requires a 4.7uF to GND at each CAP pin.
CAPL12	7	CAP	Decoupling capacitor connection for on-chip regulator. Requires two 4.7uF to GND at this CAP pin.
<b>OTHERS</b>			
NC	16	NC	Do not connect.
RES[1:0]	18, 15	GND	Reserved. Tie to Ground.

(1) The VDD (V<sub>DD33</sub> and V<sub>DDIO</sub>) supply ramp should be faster than 1.5 ms with a monotonic rise.

## 6 Specifications

### 6.1 Absolute Maximum Ratings <sup>(1) (2)</sup>

over operating free-air temperature range (unless otherwise noted)

	MIN	MAX	UNIT
Supply Voltage – $V_{DD33}$	-0.3	4.0	V
Supply Voltage – $V_{DDIO}$	-0.3	4.0	V
LVCMOS I/O Voltage <sup>(3)</sup>	-0.3	$V_{DDIO} + 0.3$	V
Serializer Output Voltage	-0.3	2.75	V
Junction Temperature		150	°C

- (1) If Military/Aerospace specified devices are required, please contact the Texas Instruments Sales Office/ Distributors for availability and specifications.
- (2) "Absolute Maximum Ratings" indicate limits beyond which damage to the device may occur, including inoperability and degradation of device reliability and/or performance. Functional operation of the device and/or non-degradation at the Absolute Maximum Ratings or other conditions beyond those indicated in the Recommended Operating Conditions is not implied. The Recommended Operating Conditions indicate conditions at which the device is functional and the device should not be operated beyond such conditions.
- (3) The maximum limit ( $V_{DDIO} + 0.3V$ ) does not apply to the PDB pin during the transition to the power down state (PDB transitioning from HIGH to LOW).

### 6.2 Handling Ratings

		MIN	MAX	UNIT	
$T_{stg}$	Storage temperature range	-65	+150	°C	
$V_{(ESD)}$	Electrostatic discharge	Human body model (HBM), per AEC Q100-002 <sup>(1)</sup>	±8	±8	kV
		Charged device model (CDM), per AEC Q100-011	±1.25	±1.25	
		Machine Model (MM)	±250	±250	V
ESD Rating (IEC 61000-4-2, powered-up only) $R_D = 330\Omega$ , $C_S = 150pF$	Air Discharge (DOUT+, DOUT-)	±15	±15	kV	
	Contact Discharge (DOUT+, DOUT-)	±8	±8		
ESD Rating (ISO 10605) $R_D = 330\Omega$ , $C_S = 150pF/330pF$ $R_D = 2K\Omega$ , $C_S = 150pF/330pF$	Air Discharge (DOUT+, DOUT-)	±15	±15		
	Contact Discharge (DOUT+, DOUT-)	±8	±8		

- (1) AEC Q100-002 indicates HBM stressing is done in accordance with the ANSI/ESDA/JEDEC JS-001 specification.

### 6.3 Recommended Operating Conditions

over operating free-air temperature range (unless otherwise noted)

	MIN	NOM	MAX	UNIT
Supply Voltage ( $V_{DD33}$ )	3.0	3.3	3.6	V
LVCMOS Supply Voltage ( $V_{DDIO}$ )	3.0	3.3	3.6	V
<b>OR</b>				
LVCMOS Supply Voltage ( $V_{DDIO}$ )	1.71	1.8	1.89	V
Operating Free Air Temperature ( $T_A$ )	-40	25	105	°C
PCLK Frequency	5		85	MHz
Supply Noise			100	mV <sub>P-P</sub>

## 6.4 Thermal Information

THERMAL METRIC <sup>(1)</sup>		RHS	UNIT
		48 PINS	
R <sub>θJA</sub>	Junction-to-ambient thermal resistance	35	°C/W
R <sub>θJC(top)</sub>	Junction-to-case (top) thermal resistance	5.2	
R <sub>θJB</sub>	Junction-to-board thermal resistance	5.5	
Ψ <sub>JT</sub>	Junction-to-top characterization parameter	0.1	
Ψ <sub>JB</sub>	Junction-to-board characterization parameter	5.5	
R <sub>θJC(bot)</sub>	Junction-to-case (bottom) thermal resistance	1.3	

(1) For more information about traditional and new thermal metrics, see the *IC Package Thermal Metrics* application report, [SPRA953](#).

## 6.5 DC Electrical Characteristics<sup>(1) (2) (3)</sup>

Over recommended operating supply and temperature ranges unless otherwise specified.

PARAMETER		TEST CONDITIONS		PIN/FREQ.	MIN	TYP	MAX	UNIT
<b>LVCMOS I/O DC SPECIFICATIONS</b>								
V <sub>IH</sub>	High Level Input Voltage	V <sub>DDIO</sub> = 3.0 to 3.6V		PDB	2.0		V <sub>DDIO</sub>	V
V <sub>IL</sub>	Low Level Input Voltage	V <sub>DDIO</sub> = 3.0 to 3.6V			GND		0.8	V
I <sub>IN</sub>	Input Current	V <sub>IN</sub> = 0V or V <sub>DDIO</sub> = 3.0 to 3.6V			-10	±1	10	μA
V <sub>IH</sub>	High Level Input Voltage	V <sub>DDIO</sub> = 3.0 to 3.6V		R[7:0], G[7:0], B[7:0], HS, VS, DE, PCLK, I2S_CLK, I2S_WC, I2S_DA, I2S_DB	2.0		V <sub>DDIO</sub>	V
		V <sub>DDIO</sub> = 1.71 to 1.89V			0.65* V <sub>DDIO</sub>		V <sub>DDIO</sub>	V
V <sub>IL</sub>	Low Level Input Voltage	V <sub>DDIO</sub> = 3.0 to 3.6V			GND		0.8	V
		V <sub>DDIO</sub> = 1.71 to 1.89V			GND		0.35* V <sub>DDIO</sub>	V
I <sub>IN</sub>	Input Current	V <sub>IN</sub> = 0V or V <sub>DDIO</sub>	V <sub>DDIO</sub> = 3.0 to 3.6V		-10	±1	10	μA
			V <sub>DDIO</sub> = 1.71 to 1.89V		-10	±1	10	μA
V <sub>OH</sub>	High Level Output Voltage	I <sub>OH</sub> = -4mA	V <sub>DDIO</sub> = 3.0 to 3.6V	GPIO[3:0], GPO_REG[8:4]	2.4		V <sub>DDIO</sub>	V
			V <sub>DDIO</sub> = 1.71 to 1.89V		V <sub>DDIO</sub> - 0.45		V <sub>DDIO</sub>	V
V <sub>OL</sub>	Low Level Output Voltage	I <sub>OL</sub> = +4mA	V <sub>DDIO</sub> = 3.0 to 3.6V		GND		0.4	V
			V <sub>DDIO</sub> = 1.71 to 1.89V		GND		0.35	V
I <sub>OS</sub>	Output Short Circuit Current	V <sub>OUT</sub> = 0V					-50	mA
I <sub>OZ</sub>	TRI-STATE® Output Current	V <sub>OUT</sub> = 0V or V <sub>DDIO</sub> , PDB = L,					-10	10

- (1) The Electrical Characteristics tables list ensured specifications under the listed Recommended Operating Conditions except as otherwise modified or specified by the Electrical Characteristics Conditions and/or Notes. Typical specifications are estimations only and are not ensured.
- (2) Typical values represent most likely parametric norms at VDD = 3.3 V, TA = +25 °C, and at the Recommended Operating Conditions at the time of product characterization and are not ensured.
- (3) Current into device pins is defined as positive. Current out of a device pin is defined as negative. Voltages are referenced to ground except V<sub>OD</sub> and ΔV<sub>OD</sub>, which are differential voltages.

**DC Electrical Characteristics<sup>(1) (2) (3)</sup> (continued)**

Over recommended operating supply and temperature ranges unless otherwise specified.

PARAMETER		TEST CONDITIONS	PIN/FREQ.	MIN	TYP	MAX	UNIT
<b>FPD-LINK III CML DRIVER DC SPECIFICATIONS</b>							
$V_{ODp-p}$	Differential Output Voltage (DOUT+) – (DOUT-)	$R_L = 100\Omega$ , <a href="#">Figure 1</a>	DOUT+, DOUT-	1160	1250	1340	mVp-p
$\Delta V_{OD}$	Output Voltage Unbalance				1	50	mV
$V_{OS}$	Offset Voltage – Single-ended	$R_L = 100\Omega$ , <a href="#">Figure 1</a>			2.5- 0.25* $V_{O_{Dp-p}}$ (TYP)		V
$\Delta V_{OS}$	Offset Voltage Unbalance Single-ended				1	50	mV
$I_{OS}$	Output Short Circuit Current	DOUT+/- = 0V, PDB = L or H			-38		mA
$R_T$	Internal Termination Resistor - Single ended				40	52	62
<b>SUPPLY CURRENT</b>							
$I_{DD1}$	Supply Current (includes load current) $R_L = 100\Omega$ , $f = 85$ MHz	Checker Board Pattern, <a href="#">Figure 2</a>	$V_{DD33} = 3.6V$	$V_{DD33}$	148	170	mA
$I_{DDIO1}$			$V_{DDIO} = 3.6V$	$V_{DDIO}$	90	180	$\mu A$
			$V_{DDIO} = 1.89V$		1	1.6	mA
$I_{DDS1}$	Supply Current Remote Auto Power Down Mode	0x01[7] = 1, deserializer is powered down	$V_{DD33} = 3.6V$	$V_{DD33}$	1.2	2.4	mA
$I_{DDIOS1}$			$V_{DDIO} = 3.6V$	$V_{DDIO}$	65	150	$\mu A$
			$V_{DDIO} = 1.89V$		55	150	$\mu A$
$I_{DDS2}$	Supply Current Power Down	PDB = L, All LVCMOS inputs are floating or tied to GND	$V_{DD33} = 3.6V$	$V_{DD33}$	1	2	mA
$I_{DDIOS2}$			$V_{DDIO} = 3.6V$	$V_{DDIO}$	65	150	$\mu A$
			$V_{DDIO} = 1.89V$		50	150	$\mu A$

**6.6 AC Electrical Characteristics**

 Over recommended operating supply and temperature ranges unless otherwise specified.<sup>(1) (2) (3)</sup>

PARAMETER		TEST CONDITIONS	PIN/FREQ.	MIN	TYP	MAX	UNIT
<b>GPIO BIT RATE</b>							
$B_R$	Forward Channel Bit Rate	See <sup>(4) (5)</sup>	$f = 5 - 85$ MHz GPIO[3:0]	0.25* $f$			Mbps
	Back Channel Bit Rate			75		kbps	
<b>RECOMMENDED TIMING for PCLK</b>							
$t_{TCP}$	PCLK Period	See <sup>(4) (5)</sup>	PCLK	11.76	T	200	ns
$t_{CIH}$	PCLK Input High Time			0.4*T	0.5*T	0.6*T	ns
$t_{CIL}$	PCLK Input Low Time			0.4*T	0.5*T	0.6*T	ns
$t_{CLKT}$	PCLK Input Transition Time <a href="#">Figure 3</a> <sup>(4) (5)</sup>		$f = 5$ MHz	4.0			ns
			$f = 85$ MHz	0.5			ns
$t_{JIT}$	PCLK Input Jitter Tolerance, Bit Error Rate $\leq 10^{-10}$	$f / 40 < \text{Jitter Freq} < f / 20$ <sup>(5) (6)</sup>	$f = 5 - 78$ MHz	0.4	0.6		UI

- (1) The Electrical Characteristics tables list ensured specifications under the listed Recommended Operating Conditions except as otherwise modified or specified by the Electrical Characteristics Conditions and/or Notes. Typical specifications are estimations only and are not ensured.
- (2) Typical values represent most likely parametric norms at  $V_{DD} = 3.3$  V,  $T_A = +25$  °C, and at the Recommended Operating Conditions at the time of product characterization and are not ensured.
- (3) Current into device pins is defined as positive. Current out of a device pin is defined as negative. Voltages are referenced to ground except  $V_{OD}$  and  $\Delta V_{OD}$ , which are differential voltages.
- (4) Specification is ensured by design and is not tested in production.
- (5) Specification is ensured by characterization and is not tested in production.
- (6) Jitter Frequency is specified in conjunction with DS90UH926 PLL bandwidth.

## 6.7 DC and AC Serial Control Bus Characteristics

Over 3.3V supply and temperature ranges unless otherwise specified.<sup>(1) (2) (3)</sup>

PARAMETER		TEST CONDITIONS	MIN	TYP	MAX	UNIT
V <sub>IH</sub>	Input High Level	SDA and SCL	0.7* V <sub>DD33</sub>		V <sub>DD33</sub>	V
V <sub>IL</sub>	Input Low Level Voltage	SDA and SCL	GND		0.3* V <sub>DD33</sub>	V
V <sub>HY</sub>	Input Hysteresis			>50		mV
V <sub>OL</sub>		SDA, I <sub>OL</sub> = 1.25 mA	0		0.36	V
I <sub>in</sub>		SDA or SCL, V <sub>IN</sub> = V <sub>DD33</sub> or GND	-10		10	μA
t <sub>R</sub>	SDA RiseTime – READ	SDA, RPU = 10 kΩ, C <sub>b</sub> ≤ 400 pF, see <a href="#">Figure 8</a>		430		ns
t <sub>F</sub>	SDA Fall Time – READ			20		ns
t <sub>SU;DAT</sub>	Set Up Time — READ	See <a href="#">Figure 8</a>		560		ns
t <sub>HD;DAT</sub>	Hold Up Time — READ	See <a href="#">Figure 8</a>		615		ns
t <sub>SP</sub>	Input Filter			50		ns
C <sub>in</sub>	Input Capacitance	SDA or SCL		<5		pF

- (1) The Electrical Characteristics tables list ensured specifications under the listed *Recommended Operating Conditions* except as otherwise modified or specified by the Electrical Characteristics Conditions and/or Notes. Typical specifications are estimations only and are not ensured.
- (2) Typical values represent most likely parametric norms at V<sub>DD</sub> = 3.3 V, T<sub>A</sub> = +25 °C, and at the *Recommended Operating Conditions* at the time of product characterization and are not ensured.
- (3) Current into device pins is defined as positive. Current out of a device pin is defined as negative. Voltages are referenced to ground except V<sub>OD</sub> and ΔV<sub>OD</sub>, which are differential voltages.

## 6.8 Recommended Timing for Serial Control Bus

Over 3.3V supply and temperature ranges unless otherwise specified.

			MIN	TYP	MAX	UNITS
f <sub>SCL</sub>	SCL Clock Frequency	Standard Mode	0		100	kHz
		Fast Mode	0		400	kHz
t <sub>LOW</sub>	SCL Low Period	Standard Mode	4.7			us
		Fast Mode	1.3			us
t <sub>HIGH</sub>	SCL High Period	Standard Mode	4.0			us
		Fast Mode	0.6			us
t <sub>HD;STA</sub>	Hold time for a start or a repeated start condition <a href="#">Figure 8</a>	Standard Mode	4.0			us
		Fast Mode	0.6			us
t <sub>SU;STA</sub>	Set Up time for a start or a repeated start condition <a href="#">Figure 8</a>	Standard Mode	4.7			us
		Fast Mode	0.6			us
t <sub>HD;DAT</sub>	Data Hold Time <a href="#">Figure 8</a>	Standard Mode	0		3.45	us
		Fast Mode	0		0.9	us
t <sub>SU;DAT</sub>	Data Set Up Time <a href="#">Figure 8</a>	Standard Mode	250			ns
		Fast Mode	100			ns
t <sub>SU;STO</sub>	Set Up Time for STOP Condition, <a href="#">Figure 8</a>	Standard Mode	4.0			us
		Fast Mode	0.6			us
t <sub>BUF</sub>	Bus Free Time Between STOP and START, <a href="#">Figure 8</a>	Standard Mode	4.7			us
		Fast Mode	1.3			us
t <sub>r</sub>	SCL & SDA Rise Time, <a href="#">Figure 8</a>	Standard Mode			1000	ns
		Fast Mode			300	ns
t <sub>f</sub>	SCL & SDA Fall Time, <a href="#">Figure 8</a>	Standard Mode			300	ns
		Fast mode			300	ns

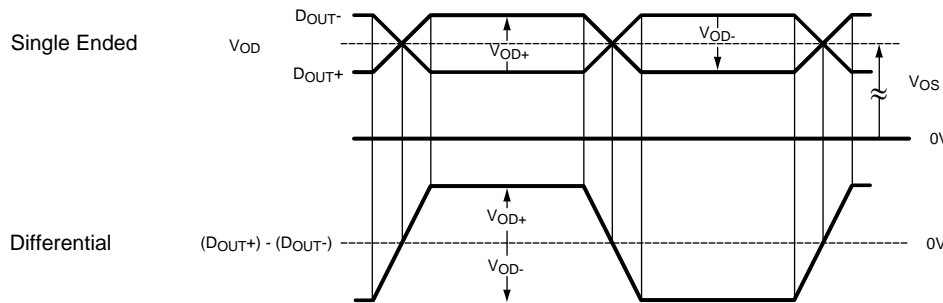
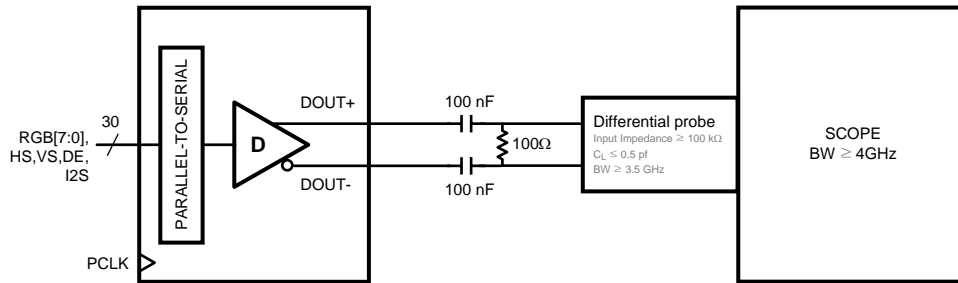

Figure 1. Serializer VOD DC Output

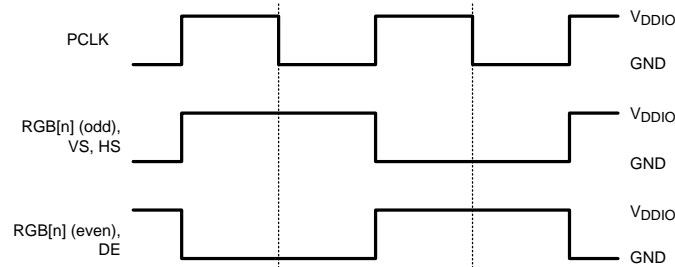

Figure 2. Checkboard Data Pattern

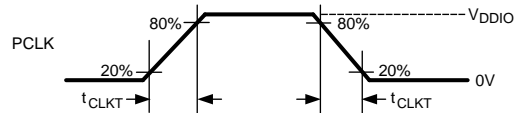

Figure 3. Serializer Input Clock Transition Time

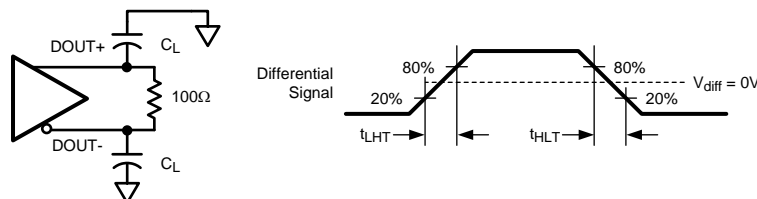

Figure 4. Serializer CML Output Load and Transition Time

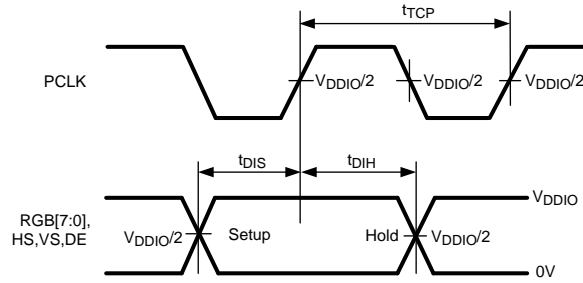

Figure 5. Serializer Setup and Hold Times

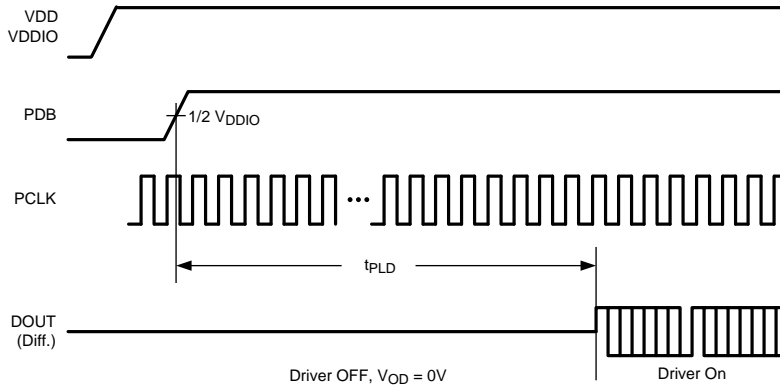

Figure 6. Serializer Lock Time

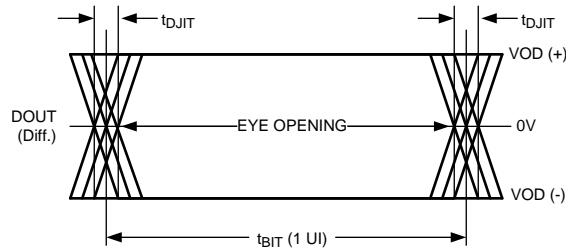

Figure 7. Serializer CML Output Jitter

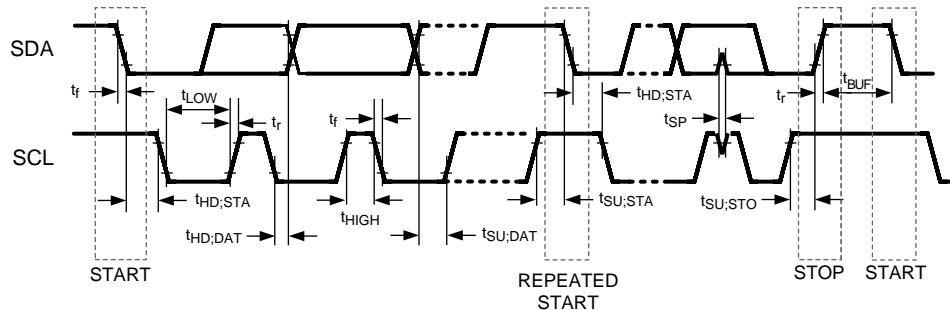

Figure 8. Serial Control Bus Timing Diagram

## 6.9 Switching Characteristics

over operating free-air temperature range (unless otherwise noted)

PARAMETER		TEST CONDITIONS		MIN	TYP	MAX	UNIT
$t_{LHT}$	CML Output Low-to-High Transition Time	See <a href="#">Figure 4</a>	DOUT+, DOUT-		80	130	ps
$t_{HLT}$	CML Output High-to-Low Transition Time				80	130	ps
$t_{DIS}$	Data Input Setup to PCLK	See <a href="#">Figure 5</a>	R[7:0], G[7:0], B[7:0], HS, VS, DE, PCLK, I2S_CLK, I2S_WC, I2S_DA, I2S_DB	2.0			ns
$t_{DIH}$	Data Input Hold from PCLK			2.0			ns
$t_{PLD}$	Serializer PLL Lock Time	<a href="#">Figure 6</a> <sup>(1)</sup>	f = 5 – 85 MHz		131*T		ns
$t_{SD}$	Delay — Latency		f = 5 – 85 MHz		145*T		ns
$t_{TJIT}$	Output Total Jitter, Bit Error Rate $\geq 10^{-10}$ <a href="#">Figure 7</a> <sup>(2)</sup> <sup>(3)</sup> <sup>(4)</sup>	$R_L = 100\Omega$ f = 85MHz, LFMODE = L	DOUT+, DOUT-		0.25	0.30	UI
		$R_L = 100\Omega$ f = 5MHz, LFMODE = H			0.25	0.30	UI

- (1)  $t_{PLD}$  is the time required by the device to obtain lock when exiting power-down state with an active PCLK.  
 (2) Specification is ensured by characterization and is not tested in production.  
 (3) Specification is ensured by design and is not tested in production.  
 (4) UI – Unit Interval is equivalent to one serialized data bit width ( $1UI = 1 / 35 * PCLK$ ). The UI scales with PCLK frequency.

## 6.10 Typical Characteristics

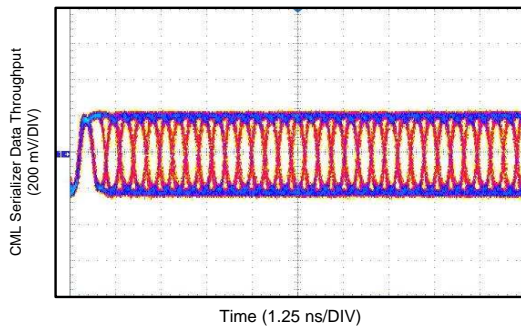

Note: On the rising edge of each clock period, the CML driver outputs a low Stop bit, high Start bit, and 33 DC-scrambled data bits.

**Figure 9. Serializer CML Driver Output with 78 MHz TX Pixel Clock**

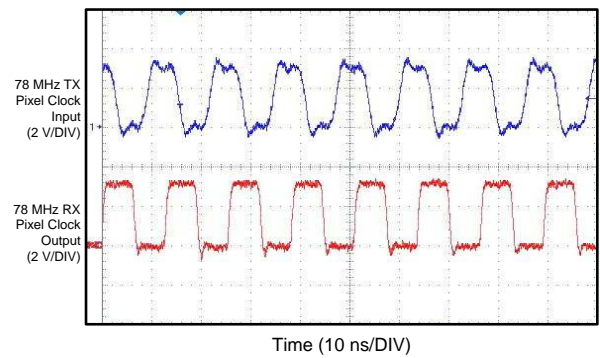

**Figure 10. Comparison of Deserializer LVCMOS RX PCLK Output Locked to a 78 MHz TX PCLK**

## 7 Detailed Description

### 7.1 Overview

The DS90UH925Q-Q1 serializer transmits a 35-bit symbol over a single serial FPD-Link III pair operating up to 2.975 Gbps line rate. The serial stream contains an embedded clock, video control signals and DC-balanced video data and audio data which enhance signal quality to support AC coupling. The DS90UH925Q-Q1 serializes video and audio data then applies encryption through a High-Bandwidth Digital Content Protection (HDCP) Cipher and transmits out through the FPD-Link III interface. Audio encryption is supported. The serializer also includes the HDCP cipher. On board non-volatile memory stores the HDCP keys. All key exchange is conducted over the FPD-Link III bidirectional control interface. The serializer is intended for use with the DS90UH926Q-Q1 deserializer, but is also backward compatible with DS90UR906Q or DS90UR908Q FPD-Link II deserializer.

### 7.2 Functional Block Diagram

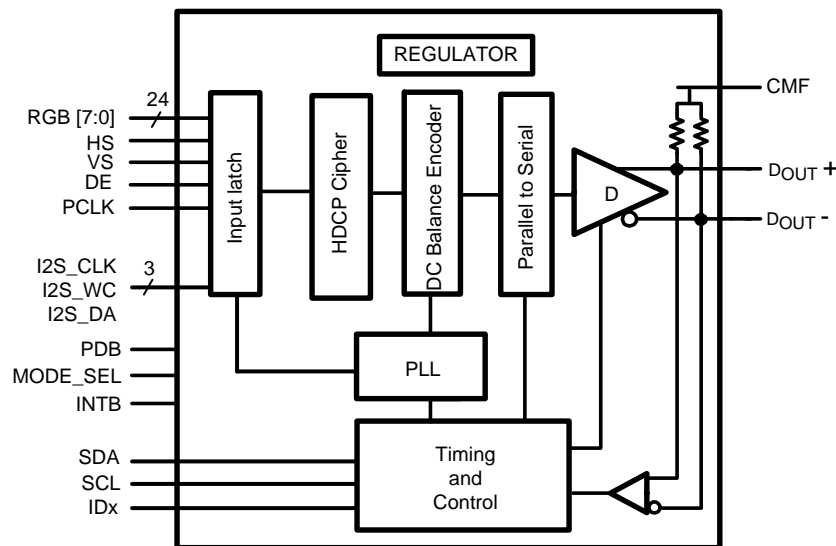

### 7.3 Feature Description

#### 7.3.1 High Speed Forward Channel Data Transfer

The High Speed Forward Channel (HS\_FC) is composed of 35 bits of data containing RGB data, sync signals, HDCP, I2C, and I2S audio transmitted from Serializer to Deserializer. Figure 11 illustrates the serial stream per PCLK cycle. This data payload is optimized for signal transmission over an AC coupled link. Data is randomized, balanced and scrambled.

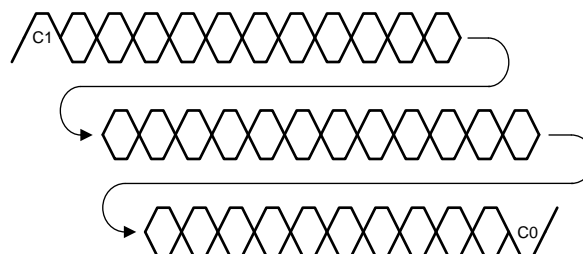

Figure 11. FPD-Link III Serial Stream

The device supports clocks in the range of 5 MHz to 85 MHz. The application payload rate is 2.975 Gbps maximum (175 Mbps minimum) with the actual line rate of 2.975 Gbps maximum and 525 Mbps Minimum.

## Feature Description (continued)

### 7.3.2 Low Speed Back Channel Data Transfer

The Low-Speed Backward Channel (LS\_BC) of the DS90UH925Q-Q1 provides bidirectional communication between the display and host processor. The information is carried back from the Deserializer to the Serializer per serial symbol. The back channel control data is transferred over the single serial link along with the high-speed forward data, DC balance coding and embedded clock information. This architecture provides a backward path across the serial link together with a high speed forward channel. The back channel contains the I2C, HDCP, CRC and 4 bits of standard GPIO information with 10 Mbps line rate.

### 7.3.3 Backward Compatible Mode

The DS90UH925Q-Q1 is also backward compatible to DS90UR906Q and DS90UR908Q FPD Link II deserializers at 5-65 MHz of PCLK. It transmits 28-bits of data over a single serial FPD-Link II pair operating at the line rate of 140 Mbps to 1.82 Gbps. The backward configuration mode can be set via MODE\_SEL pin (Table 4) or the configuration register (Table 6). Note: frequency range = 15 - 65MHz when LFMODE = 0 and frequency range = 5 - <15MHz when LFMODE = 1.

### 7.3.4 Common Mode Filter Pin (CMF)

The serializer provides access to the center tap of the internal termination. A capacitor must be placed on this pin for additional common-mode filtering of the differential pair. This can be useful in high noise environments for additional noise rejection capability. A 0.1  $\mu$ F capacitor must be connected to this pin to Ground.

### 7.3.5 Video Control Signal Filter

When operating the devices in Normal Mode, the Video Control Signals (DE, HS, VS) have the following restrictions:

- Normal Mode with Control Signal Filter Enabled: DE and HS — Only 2 transitions per 130 clock cycles are transmitted, the transition pulse must be 3 PCLK or longer.
- Normal Mode with Control Signal Filter Disabled: DE and HS — Only 2 transitions per 130 clock cycles are transmitted, no restriction on minimum transition pulse.
- VS — Only 1 transition per 130 clock cycles are transmitted, minimum pulse width is 130 clock cycles.

Video Control Signals are defined as low frequency signals with limited transitions. Glitches of a control signal can cause a visual display error. This feature allows for the chipset to validate and filter out any high frequency noise on the control signals. See Figure 12.

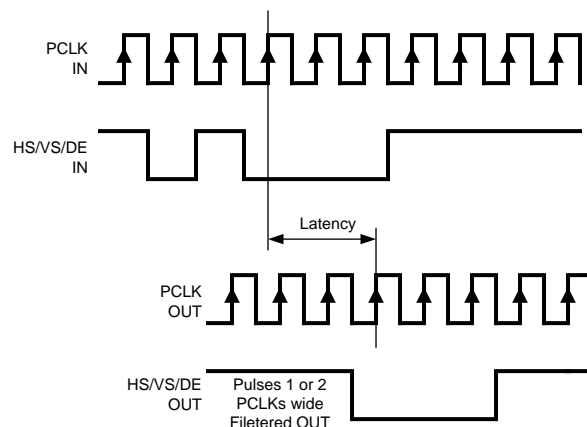

Figure 12. Video Control Signal Filter Waveform

## Feature Description (continued)

### 7.3.6 Power Down (PDB)

The Serializer has a PDB input pin to ENABLE or POWER DOWN the device. This pin can be controlled by the host or through the  $V_{DDIO}$ , where  $V_{DDIO} = 3.0V$  to  $3.6V$  or  $V_{DD33}$ . To save power disable the link when the display is not needed (PDB = LOW). When the pin is driven by the host, make sure to release it after  $V_{DD33}$  and  $V_{DDIO}$  have reached final levels; no external components are required. In the case of driven by the  $V_{DDIO} = 3.0V$  to  $3.6V$  or  $V_{DD33}$  directly, a 10 kohm resistor to the  $V_{DDIO} = 3.0V$  to  $3.6V$  or  $V_{DD33}$ , and a >10uF capacitor to the ground are required see [Figure 23](#).

### 7.3.7 Remote Auto Power Down Mode

The Serializer features a remote auto power down mode. During the power down mode of the pairing deserializer, the Serializer enters the remote auto power down mode. In this mode, the power dissipation of the Serializer is reduced significantly. When the Deserializer is powered up, the Serializer enters the normal power on mode automatically. This feature is enabled through the register bit 0x01[7] [Table 6](#).

### 7.3.8 LVCMOS $V_{DDIO}$ Option

1.8V or 3.3V Inputs and Outputs are powered from a separate  $V_{DDIO}$  supply to offer compatibility with external system interface signals. Note: When configuring the  $V_{DDIO}$  power supplies, all the single-ended data and control input pins for device need to scale together with the same operating  $V_{DDIO}$  levels.

### 7.3.9 Input PCLK Loss Detect

The serializer can be programmed to enter a low power SLEEP state when the input clock (PCLK) is lost. A clock loss condition is detected when PCLK drops below approximately 1MHz. When a PCLK is detected again, the serializer will then lock to the incoming PCLK. Note – when PCLK is lost, the Serial Control Bus Registers values are still RETAINED.

### 7.3.10 Serial Link Fault Detect

The serial link fault detection is able to detect any of following seven (7) conditions

1. cable open
2. “+” to “-“ short
3. “+” short to GND
4. “-“ short to GND
5. “+” short to battery
6. “-“ short to battery
7. Cable is linked correctly

If any one of the fault conditions occurs, The Link Detect Status is 0 (cable is not detected) on bit 0 of address 0x0C [Table 6](#).

### 7.3.11 Pixel Clock Edge Select (RFB)

The RFB control register bit selects which edge of the Pixel Clock is used. For the serializer, this pin determines the edge that the data is latched on. If RFB is HIGH ('1'), data is latched on the Rising edge of the PCLK. If RFB is LOW ('0'), data is latched on the Falling edge of the PCLK.

### 7.3.12 Low Frequency Optimization (LFMODE)

The LFMODE is set via register (0x04[1:0]) or MODE\_SEL Pin 24 ([Table 4](#)). It controls the operating frequency of the serializer. If LFMODE is Low (default), the PCLK frequency is between 15 MHz and 85 MHz. If LFMODE is High, the PCLK frequency is between 5 MHz and <15 MHz. Please note when the device LFMODE is changed, a PDB reset is required.

## Feature Description (continued)

### 7.3.13 Interrupt Pin — Functional Description and Usage (INTB)

1. On DS90UH925Q-Q1, set register 0xC6[5] = 1 and 0xC6[0] = 1
2. DS90UH926Q-Q1 deserializer INTB\_IN (pin 16) is set LOW by some downstream device.
3. DS90UH925Q-Q1 serializer pulls INTB (pin 31) LOW. The signal is active low, so a LOW indicates an interrupt condition.
4. External controller detects INTB = LOW; to determine interrupt source, read HDCP\_ISR register .
5. A read to HDCP\_ISR will clear the interrupt at the DS90UH925Q-Q1, releasing INTB.
6. The external controller typically must then access the remote device to determine downstream interrupt source and clear the interrupt driving INTB\_IN. This would be when the downstream device releases the INTB\_IN (pin 16) on the DS90UH926Q-Q1. The system is now ready to return to step (1) at next falling edge of INTB\_IN.

### 7.3.14 EMI Reduction Features

#### 7.3.14.1 Input SSC Tolerance (SSCT)

The DS90UH925Q-Q1 serializer is capable of tracking a triangular input spread spectrum clocking (SSC) profile up to +/-2.5% amplitude deviations (center spread), up to 35 kHz modulation at 5–85 MHz, from a host source.

#### 7.3.14.2 GPIO[3:0] and GPO\_REG[8:4]

In 18-bit RGB operation mode, the optional R[1:0] and G[1:0] of the DS90UH925Q-Q1 can be used as the general purpose IOs GPIO[3:0] in either forward channel (Inputs) or back channel (Outputs) application.

##### 7.3.14.2.1 GPIO[3:0] Enable Sequence

See [Table 1](#) for the GPIO enable sequencing.

**Step 1:** Enable the 18-bit mode either through the configuration register bit [Table 6](#) on DS90UH925Q-Q1 only. DS90UH926Q-Q1 is automatically configured as in the 18-bit mode.

**Step 2:** To enable GPIO3 forward channel, write 0x03 to address 0x0F on DS90UH925Q-Q1, then write 0x05 to address 0x1F on DS90UH926Q-Q1.

**Table 1. GPIO Enable Sequencing Table**

#	DESCRIPTION	DEVICE	FORWARD CHANNEL	BACK CHANNEL
1	Enable 18-bit mode	DS90UH925Q-Q1	0x12 = 0x04	0x12 = 0x04
		DS90UH926Q-Q1	Auto Load from DS90UH925Q-Q1	Auto Load from DS90UH925Q-Q1
2	GPIO3	DS90UH925Q-Q1	0x0F = 0x03	0x0F = 0x05
		DS90UH926Q-Q1	0x1F = 0x05	0x1F = 0x03
3	GPIO2	DS90UH925Q-Q1	0x0E = 0x30	0x0E = 0x50
		DS90UH926Q-Q1	0x1E = 0x50	0x1E = 0x30
4	GPIO1	DS90UH925Q-Q1	0x0E = 0x03	0x0E = 0x05
		DS90UH926Q-Q1	0x1E = 0x05	0x1E = 0x03
5	GPIO0	DS90UH925Q-Q1	0x0D = 0x93	0x0D = 0x95
		DS90UH926Q-Q1	0x1D = 0x95	0x1D = 0x93

##### 7.3.14.2.2 GPO\_REG[8:4] Enable Sequence

GPO\_REG[8:4] are the outputs only pins. They must be programmed through the local register bits. See [Table 2](#) for the GPO\_REG enable sequencing.

**Step 1:** Enable the 18-bit mode either through the configuration register bit [Table 6](#) on DS90UH925Q-Q1 only. DS90UH926Q-Q1 is automatically configured as in the 18-bit mode.

**Step 2:** To enable GPO\_REG8 outputs an “1”, write 0x90 to address 0x11 on DS90UH925Q-Q1.

**Table 2. GPO\_REG Enable Sequencing Table**

#	DESCRIPTION	DEVICE	LOCAL ACCESS	LOCAL OUTPUT
1	Enable 18-bit mode	DS90UH925Q-Q1	0x12 = 0x04	
2	GPO_REG8	DS90UH925Q-Q1	0x11 = 0x90	"1"
			0x11 = 0x10	"0"
3	GPO_REG7	DS90UH925Q-Q1	0x11 = 0x09	"1"
			0x11 = 0x01	"0"
4	GPO_REG6	DS90UH925Q-Q1	0x10 = 0x90	"1"
			0x10 = 0x10	"0"
5	GPO_REG5	DS90UH925Q-Q1	0x10 = 0x09	"1"
			0x10 = 0x01	"0"
6	GPO_REG4	DS90UH925Q-Q1	0x0F = 0x90	"1"
			0x0F = 0x10	"0"

### 7.3.14.3 I2S Transmitting

In normal 24-bit RGB operation mode, the DS90UH925Q-Q1 supports 3 bits of I2S. They are I2S\_CLK, I2S\_WC and I2S\_DA. The optionally encrypted and packetized audio information can be transmitted during the video blanking (data island transport) or during active video (forward channel frame transport). Note: The bit rates of any I2S bits must maintain one fourth of the PCLK rate. The audio encryption capability is supported per HDCP v1.3.

#### 7.3.14.3.1 Secondary I2S Channel

In I2S Channel B operation mode, the secondary I2S data (I2S\_DB) can be used as the additional I2S audio in addition to the 3-bit of I2S. The I2S\_DB input must be synchronized to I2S\_CLK and aligned with I2S\_DA and I2S\_WC at the input to the serializer. This operation mode is enabled through either the MODE\_SEL pin (Table 4) or through the register bit 0x12[0] (Table 6). Table 3 below covers the range of I2S sample rates.

**Table 3. Audio Interface Frequencies**

SAMPLE RATE (kHz)	I2S DATA WORD SIZE (bits)	I2S CLK (MHz)
32	16	1.024
44.1	16	1.411
48	16	1.536
96	16	3.072
192	16	6.144
32	24	1.536
44.1	24	2.117
48	24	2.304
96	24	4.608
192	24	9.216
32	32	2.048
44.1	32	2.822
48	32	3.072
96	32	6.144
192	32	12.288

#### 7.3.14.4 HDCP

The Cipher function is implemented in the serializer per HDCP v1.3 specification. The DS90UH925Q-Q1 provides HDCP encryption of audiovisual content when connected to an HDCP capable FPD-Link III deserializer such as the DS90UH926Q-Q1. HDCP authentication and shared key generation is performed using the HDCP Control Channel which is embedded in the forward and backward channels of the serial link. An on-chip Non-Volatile Memory (NVM) is used to store the HDCP keys. The confidential HDCP keys are loaded by TI during the manufacturing process and are not accessible external to the device.

The DS90UH925Q-Q1 uses the Cipher engine to encrypt the data as per HDCP v1.3. The encrypted data is transmitted through the FPD-Link III interface.

#### 7.3.14.5 Built In Self Test (BIST)

An optional At-Speed Built In Self Test (BIST) feature supports the testing of the high speed serial link and the low-speed back channel. This is useful in the prototype stage, equipment production, in-system test and also for system diagnostics. Note: BIST not available in backwards compatible mode.

##### 7.3.14.5.1 BIST Configuration and Status

The BIST mode is enabled at the deserializer by the Pin select (Pin 44 BISTEN and Pin 16 BISTC) or configuration register (Table 6) through the deserializer. When LFMODE = 0, the pin based configuration defaults to external PCLK or 33 MHz internal Oscillator clock (OSC) frequency. In the absence of PCLK, the user can select the desired OSC frequency (default 33 MHz or 25MHz) through the register bit. When LFMODE = 1, the pin based configuration defaults to external PCLK or 12.5MHz internal Oscillator clock (OSC) frequency.

When BISTEN of the deserializer is high, the BIST mode enable information is sent to the serializer through the Back Channel. The serializer outputs a test pattern and drives the link at speed. The deserializer detects the test pattern and monitors it for errors. The PASS output pin toggles to flag any payloads that are received with 1 to 35 bit errors.

The BIST status is monitored real time on PASS pin. The result of the test is held on the PASS output until reset (new BIST test or Power Down). A high on PASS indicates NO ERRORS were detected. A Low on PASS indicates one or more errors were detected. The duration of the test is controlled by the pulse width applied to the deserializer BISTEN pin. This BIST feature also contains a Link Error Count and a Lock Status. If the connection of the serial link is broken, then the link error count is shown in the register. When the PLL of the deserializer is locked or unlocked, the lock status can be read in the register. See Table 6.

##### 7.3.14.5.1.1 Sample BIST Sequence

See Figure 13 for the BIST mode flow diagram.

**Step 1:** For the DS90UH925Q-Q1 and DS90UH926Q-Q1 FPD-Link III chipset, BIST Mode is enabled via the BISTEN pin of DS90UH926Q-Q1 FPD-Link III deserializer. The desired clock source is selected through BISTC pin.

**Step 2:** The DS90UH925Q-Q1 serializer is woken up through the back channel if it is not already on. The all zero pattern on the data pins is sent through the FPD-Link III to the deserializer. Once the serializer and the deserializer are in BIST mode and the deserializer acquires Lock, the PASS pin of the deserializer goes high and BIST starts checking the data stream. If an error in the payload (1 to 35) is detected, the PASS pin will switch low for one half of the clock period. During the BIST test, the PASS output can be monitored and counted to determine the payload error rate.

**Step 3:** To Stop the BIST mode, the deserializer BISTEN pin is set Low. The deserializer stops checking the data. The final test result is held on the PASS pin. If the test ran error free, the PASS output will be High. If there was one or more errors detected, the PASS output will be Low. The PASS output state is held until a new BIST is run, the device is RESET, or Powered Down. The BIST duration is user controlled by the duration of the BISTEN signal.

**Step 4:** The Link returns to normal operation after the deserializer BISTEN pin is low. Figure 14 shows the waveform diagram of a typical BIST test for two cases. Case 1 is error free, and Case 2 shows one with multiple errors. In most cases it is difficult to generate errors due to the robustness of the link (differential data transmission etc.), thus they may be introduced by greatly extending the cable length, faulting the interconnect, reducing signal condition enhancements (Rx Equalization).

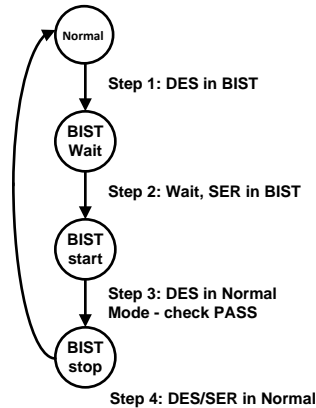

Figure 13. BIST Mode Flow Diagram

7.3.14.5.2 Forward Channel and Back Channel Error Checking

While in BIST mode, the serializer stops sampling RGB input pins and switches over to an internal all-zero pattern. The internal all-zeroes pattern goes through scrambler, dc-balancing etc. and goes over the serial link to the deserializer. The deserializer on locking to the serial stream compares the recovered serial stream with all-zeroes and records any errors in status registers and dynamically indicates the status on PASS pin. The deserializer then outputs a SSO pattern on the RGB output pins.

The back-channel data is checked for CRC errors once the serializer locks onto back-channel serial stream as indicated by link detect status (register bit 0x0C[0]). The CRC errors are recorded in an 8-bit register. The register is cleared when the serializer enters the BIST mode. As soon as the serializer exits BIST mode, the functional mode CRC register starts recording the CRC errors. The BIST mode CRC error register is active in BIST mode only and keeps the record of last BIST run until cleared or enters BIST mode again.

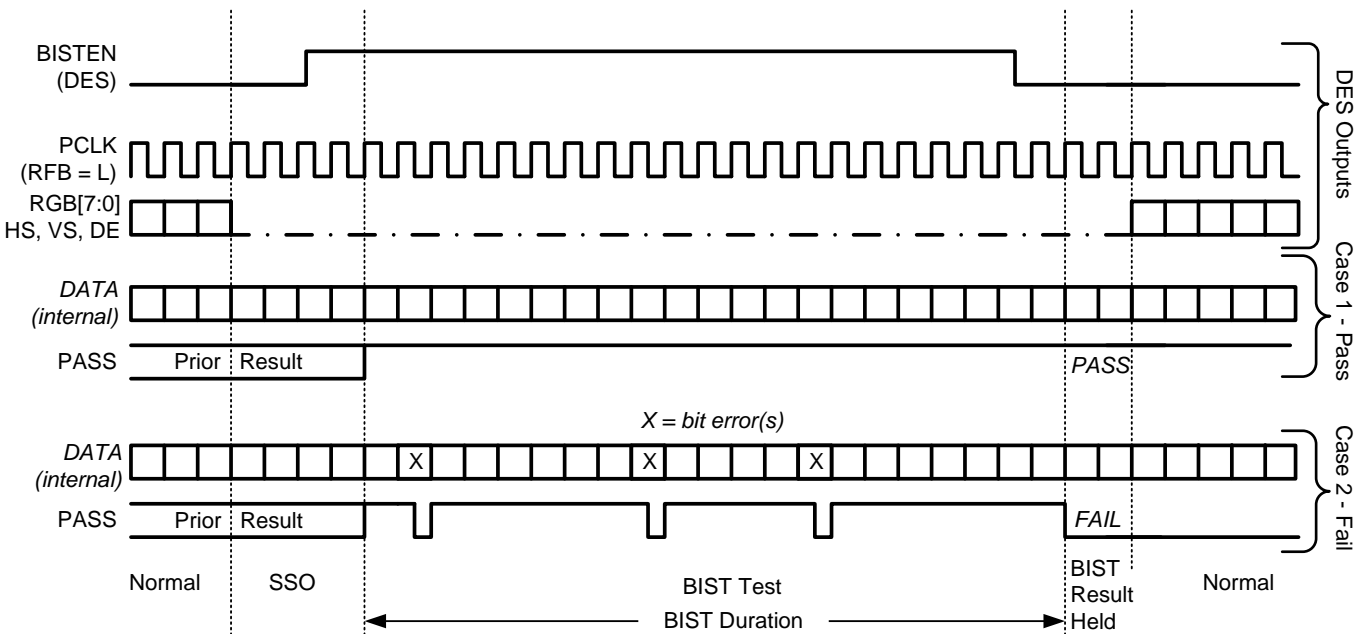

Figure 14. BIST Waveforms

### 7.3.14.6 Internal Pattern Generation

The DS90UH925Q-Q1 serializer supports the internal pattern generation feature. It allows basic testing and debugging of an integrated panel through the FPD-Link III output stream. The test patterns are simple and repetitive and allow for a quick visual verification of panel operation. As long as the device is not in power down mode, the test pattern will be displayed even if no parallel input is applied. If no PCLK is received, the test pattern can be configured to use a programmed oscillator frequency. For detailed information, refer to [SNLA132](#).

## 7.4 Device Functional Modes

### 7.4.1 Configuration Select (MODE\_SEL)

Configuration of the device may be done via the MODE\_SEL input pin, or via the configuration register bit. A pull-up resistor and a pull-down resistor of suggested values may be used to set the voltage ratio of the MODE\_SEL input ( $V_{R4}$ ) and  $V_{DD33}$  to select one of the other 10 possible selected modes. See [Figure 15](#) and [Table 4](#).

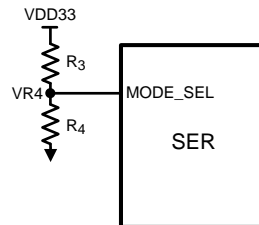

Figure 15. MODE\_SEL Connection Diagram

**Device Functional Modes (continued)**
**Table 4. Configuration Select (MODE\_SEL)**

#	IDEAL RATIO $V_{R4}/V_{DD33}$	IDEAL $V_{R4}$ (V)	SUGGESTED RESISTOR R3 k $\Omega$ (1% tol)	SUGGESTED RESISTOR R4 k $\Omega$ (1% tol)	LFMODE	REPEATER	BACKWARD COMPATIBLE	I2S CHANNEL B (18-bit MODE)
1	0	0	Open	40.2 or Any	L	L	L	L
2	0.164	0.541	255	49.9	L	H	L	L
3	0.221	0.729	243	69.8	L	H	L	H
4	0.285	0.941	237	95.3	H	L	L	L
5	0.359	1.185	196	110	H	L	L	H
6	0.453	1.495	169	140	H	H	L	L
7	0.539	1.779	137	158	H	H	L	H
8	0.728	2.402	90.9	243	H	L	H*	L

**LFMODE:**

L = frequency range is 15 – 85 MHz (Default)

H = frequency range is 5 – &lt;15 MHz

**Repeater:**

 L = Repeater *OFF* (Default)

 H = Repeater *ON*
**Backward Compatible:**

 L = Backward Compatible is *OFF* (Default)

 H = Backward Compatible is *ON*; DES = DS90UR906Q or DS90UR916Q or DS90UR908Q

– frequency range = 15 - 65 MHz when LFMODE = 0

– frequency range = 5 - &lt;15 MHz when LFMODE = 1

**I2S Channel B:**

 L = I2S Channel B is *OFF*, Normal 24-bit RGB Mode (Default)

 H = I2S Channel B is *ON*, 18-bit RGB Mode with I2S\_DB Enabled. Note: use of GPIO(s) on unused inputs must be enabled by register.

**7.4.2 HDCP Repeater**

When DS90UH925Q-Q1 and DS90UH926Q-Q1 are configured as the HDCP Repeater application, it provides a mechanism to extend HDCP transmission over multiple links to multiple display devices. This repeater application provides a mechanism to authenticate all HDCP Receivers in the system and distribute protected content to the HDCP Receivers using the encryption mechanisms provided in the HDCP specification.

### 7.4.3 Repeater Configuration

In HDCP repeater application, In this document, the DS90UH925Q-Q1 is referred to as the HDCP Transmitter or transmit port (TX), and the DS90UH926Q-Q1 is referred to as the HDCP Receiver (RX). [Figure 16](#) shows the maximum configuration supported for HDCP Repeater implementations using the DS90UH925Q-Q1 (TX) and DS90UH926Q-Q1 (RX). Two levels of HDCP Repeaters are supported with a maximum of three HDCP Transmitters per HDCP Receiver.

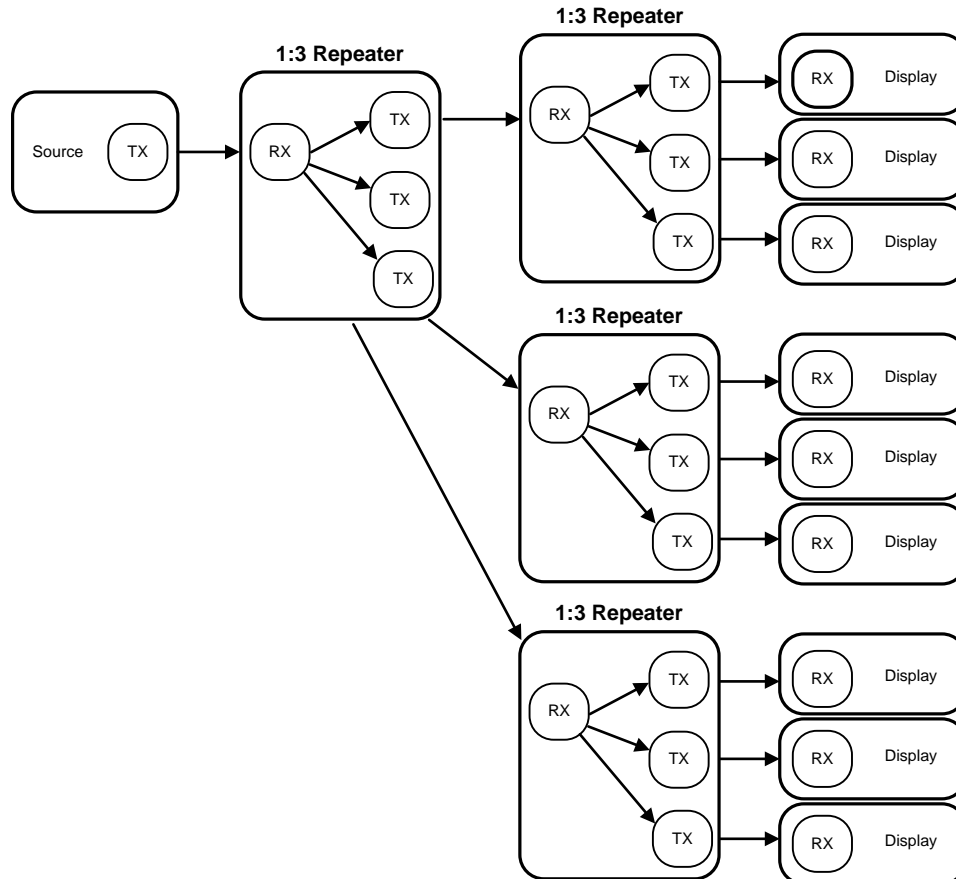

**Figure 16. HDCP Maximum Repeater Application**

To support HDCP Repeater operation, the DS90UH926Q-Q1 Deserializer includes the ability to control the downstream authentication process, assemble the KSV list for downstream HDCP Receivers, and pass the KSV list to the upstream HDCP Transmitter. An I2C master within the DS90UH926Q-Q1 communicates with the I2C slave within the DS90UH925Q-Q1 Serializer. The DS90UH925Q-Q1 Serializer handles authenticating with a downstream HDCP Receiver and makes status available through the I2C interface. The DS90UH926Q-Q1 monitors the transmit port status for each DS90UH925Q-Q1 and reads downstream KSV and KSV list values from the DS90UH925Q-Q1.

In addition to the I2C interface used to control the authentication process, the HDCP Repeater implementation includes two other interfaces. A parallel LVCMOS interface provides the unencrypted video data in 24-bit RGB format and includes the DE/VS/HS control signals. In addition to providing the RGB video data, the parallel LVCMOS interface communicates control information and packetized audio data during video blanking intervals. A separate I2S audio interface may optionally be used to send I2S audio data between the HDCP Receiver and HDCP Transmitter in place of using the packetized audio over the parallel LVCMOS interface. All audio and video data is decrypted at the output of the HDCP Receiver and is re-encrypted by the HDCP Transmitter.

Figure 17 provides more detailed block diagram of a 1:2 HDCP repeater configuration.

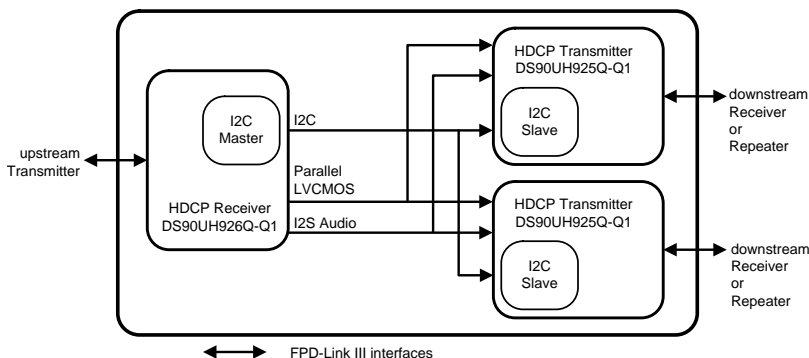

Figure 17. HDCP 1:2 Repeater Configuration

### 7.4.4 Repeater Connections

The HDCP Repeater requires the following connections between the HDCP Receiver and each HDCP Transmitter [Figure 18](#).

1. Video Data – Connect PCLK, RGB and control signals (DE, VS, HS).
2. I2C – Connect SCL and SDA signals. Both signals should be pulled up to  $V_{DD33}$  with 4.7 k $\Omega$  resistors.
3. Audio – Connect I2S\_CLK, I2S\_WC, and I2S\_DA signals.
4. IDx pin – Each HDCP Transmitter and Receiver must have an unique I2C address.
5. MODE\_SEL pin – All HDCP Transmitter and Receiver must be set into the Repeater Mode.
6. Interrupt pin – Connect DS90UH926Q-Q1 INTB\_IN pin to DS90UH925Q-Q1 INTB pin. The signal must be pulled up to  $V_{DDIO}$ .

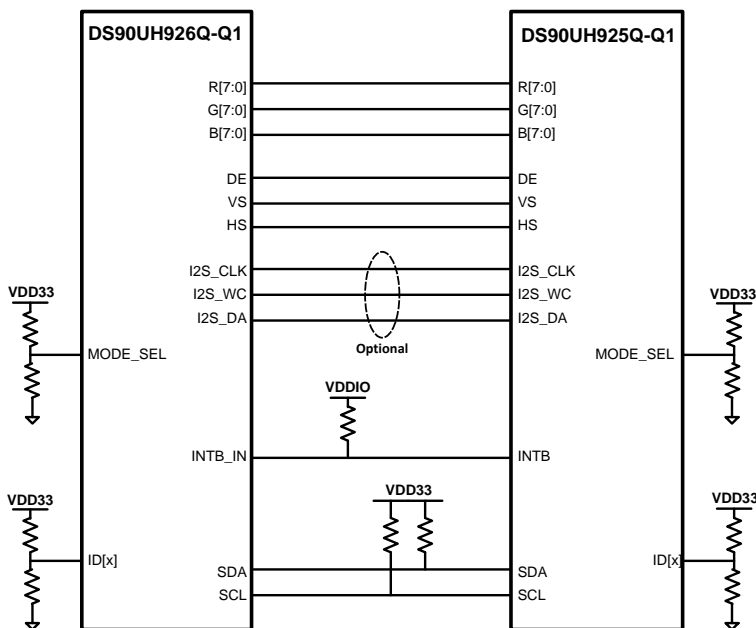

Figure 18. HDCP Repeater Connection Diagram

## 7.5 Programming

### 7.5.1 Serial Control Bus

The DS90UH925Q-Q1 is configured by the use of a serial control bus that is I2C protocol compatible. This bus is also used by the Host source to control and monitor status of the HDCP function. Multiple serializer devices may share the serial control bus since 16 device addresses are supported. Device address is set via  $R_1$  and  $R_2$  values on IDx pin. See Figure 19 below.

The serial control bus consists of two signals and a configuration pin. The SCL is a Serial Bus Clock Input / Output. The SDA is the Serial Bus Data Input / Output signal. Both SCL and SDA signals require an external pull-up resistor to  $V_{DD33}$ . For most applications a 4.7 k pull-up resistor to  $V_{DD33}$  may be used. The resistor value may be adjusted for capacitive loading and data rate requirements. The signals are either pulled High, or driven Low.

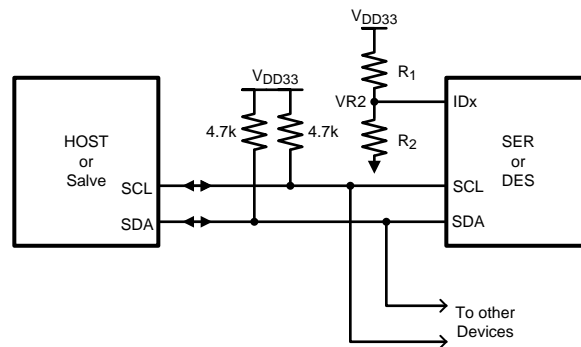

Figure 19. Serial Control Bus Connection

The configuration pin is the IDx pin. This pin sets one of 9 possible device addresses. A pull-up resistor and a pull-down resistor of suggested values may be used to set the voltage ratio of the IDx input ( $V_{R2}$ ) and  $V_{DD33}$  to select one of the other 9 possible addresses. Table 5 defines the required  $V_{R2}$  and  $V_{R2}/V_{DD33}$  ratios, and suggests standard resistor values to achieve these ratios. In systems where excessive noise may be present, we recommend reducing the resistor values (by a factor of 10x or 100x) while maintaining the required ratio. This provides tighter coupling to supply rails, and more stability of  $V_{R2}$  in the presence of coupled noise. Note that reducing the resistor values will increase the current consumed by the resistor divider. See Table 5.

Table 5. Serial Control Bus Addresses for IDx

#	IDEAL RATIO $V_{R2} / V_{DD33}$	IDEAL $V_{R2}$ (V)	SUGGESTED RESISTOR $R_1$ k $\Omega$ (1% tol)	SUGGESTED RESISTOR $R_2$ k $\Omega$ (1% tol)	ADDRESS 7'b	ADDRESS 8'b APPENDED
1	0	0	Open	40.2 or Any	0x0C	0x18
2	0.121	0.399	294	40.2	0x0D	0x1A
3	0.152	0.502	280	49.9	0x0E	0x1C
4	0.180	0.594	137	30.1	0x0F	0x1E
5	0.208	0.685	118	30.9	0x10	0x20
6	0.303	0.999	115	49.9	0x13	0x26
7	0.345	1.137	102	53.6	0x14	0x28
8	0.389	1.284	115	73.2	0x15	0x2A
9	0.727	2.399	90.9	243	0x1B	0x36

The Serial Bus protocol is controlled by START, START-Repeated, and STOP phases. A START occurs when SCL transitions Low while SDA is High. A STOP occurs when SDA transition High while SCL is also HIGH. See Figure 20.

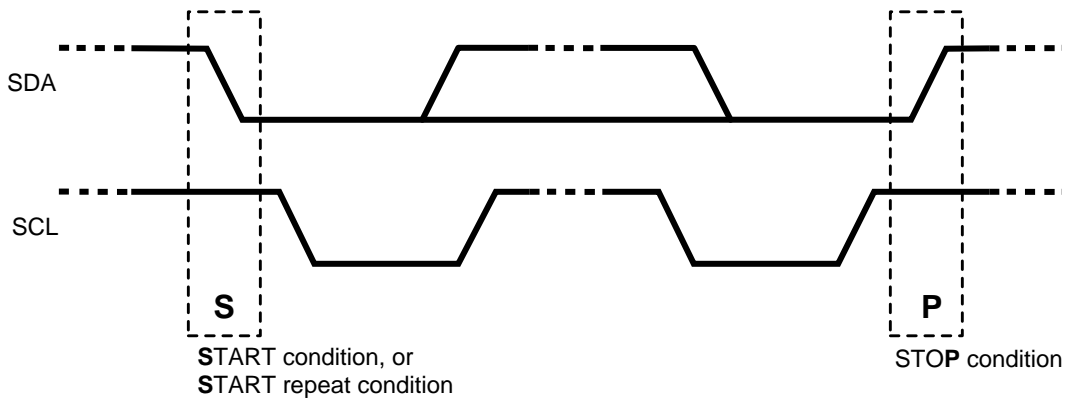

Figure 20. START and STOP Conditions

To communicate with a remote device, the host controller (master) sends the slave address and listens for a response from the slave. This response is referred to as an acknowledge bit (ACK). If a slave on the bus is addressed correctly, it Acknowledges (ACKs) the master by driving the SDA bus low. If the address doesn't match a device's slave address, it Not-acknowledges (NACKs) the master by letting SDA be pulled High. ACKs also occur on the bus when data is being transmitted. When the master is writing data, the slave ACKs after every data byte is successfully received. When the master is reading data, the master ACKs after every data byte is received to let the slave know it wants to receive another data byte. When the master wants to stop reading, it NACKs after the last data byte and creates a stop condition on the bus. All communication on the bus begins with either a Start condition or a Repeated Start condition. All communication on the bus ends with a Stop condition. A READ is shown in Figure 21 and a WRITE is shown in Figure 22.

If the Serial Bus is not required, the three pins may be left open (NC).

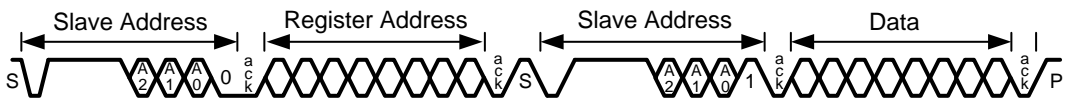

Figure 21. Serial Control Bus — READ

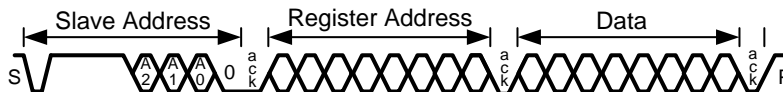

Figure 22. Serial Control Bus — WRITE

## 7.6 Register Maps

**Table 6. Serial Control Bus Registers**

ADD (dec)	ADD (hex)	REGISTER NAME	Bit(s)	REGISTER TYPE	DEFAULT (hex)	FUNCTION	DESCRIPTION
0	0x00	I2C Device ID	7:1	RW		Device ID	7-bit address of Serializer
			0	RW		ID Setting	I2C ID Setting 1: Register I2C Device ID (Overrides IDx pin) 0: Device ID is from IDx pin
1	0x01	Reset	7	RW	0x00	Remote Auto Power Down	Remote Auto Power Down 1: Power down when no Bidirectional Control Channel link is detected 0: Do not power down when no Bidirectional Control Channel link is detected
			6:2				<b>Reserved.</b>
			1	RW		Digital RESET1	Reset the entire digital block including registers This bit is self-clearing. 1: Reset 0: Normal operation
			0	RW		Digital RESET0	Reset the entire digital block except registers This bit is self-clearing 1: Reset 0: Normal operation
3	0x03	Configuration [0]	7	RW	0xD2	Back channel CRC Checker Enable	Back Channel Check Enable 1: Enable 0: Disable
			6				<b>Reserved.</b>
			5	RW		I2C Remote Write Auto Acknowledge	Automatically Acknowledge I2C Remote Write When enabled, I2C writes to the Deserializer (or any remote I2C Slave, if I2C PASS ALL is enabled) are immediately acknowledged without waiting for the Deserializer to acknowledge the write. This allows higher throughput on the I2C bus 1: Enable 0: Disable
			4	RW		Filter Enable	HS, VS, DE two clock filter When enabled, pulses less than two full PCLK cycles on the DE, HS, and VS inputs will be rejected 1: Filtering enable 0: Filtering disable
			3	RW		I2C Pass-through	I2C Pass-Through Mode 1: Pass-Through Enabled 0: Pass-Through Disabled
			2				<b>Reserved</b>
			1	RW		PCLK Auto	Switch over to internal OSC in the absence of PCLK 1: Enable auto-switch 0: Disable auto-switch
			0	RW		TRFB	Pixel Clock Edge Select 1: Parallel Interface Data is strobed on the Rising Clock Edge. 0: Parallel Interface Data is strobed on the Falling Clock Edge.

**Register Maps (continued)**
**Table 6. Serial Control Bus Registers (continued)**

ADD (dec)	ADD (hex)	REGISTER NAME	Bit(s)	REGISTER TYPE	DEFAULT (hex)	FUNCTION	DESCRIPTION
4	0x04	Configuration [1]	7	RW	0x80	Failsafe State	Input Failsafe State 1: Failsafe to Low 0: Failsafe to High
			6			<b>Reserved</b>	
			5	RW		CRC Error Reset	Clear back channel CRC Error Counters This bit is NOT self-clearing 1: Clear Counters 0: Normal Operation
			4			<b>Reserved</b>	
			3	RW		Backward Compatible select by pin or register control	Backward Compatible (BC) mode set by MODE_SEL pin or register 1: BC is set by register bit. Use register bit reg_0x04[2] to set BC Mode 0: BC is set by MODE_SEL pin.
			2	RW		Backward Compatible Mode Select	Backward compatible (BC) mode to DS90UR906Q or DS90UR908Q, if reg_0x04[3] = 1 1: Backward compatible with DS90UR906Q or DS90UR908Q 0: Backward Compatible is OFF (default)
			1	RW		LFMODE select by pin or register control	Frequency range is set by MODE_SEL pin or register 1: Frequency range is set by register. Use register bit reg_0x04[0] to set LFMODE 0: Frequency range is set by MODE_SEL pin.
			0	RW		LFMODE	Frequency range select 1: PCLK range = 5MHz - <15 MHz, if reg_0x04[1] = 1 0: PCLK range = 15MHz - 85MHz (default)
5	0x05	I2C Control	7:5		0x00		<b>Reserved</b>
			4:3	RW		SDA Output Delay	SDA output delay Configures output delay on the SDA output. Setting this value will increase output delay in units of 40ns. Nominal output delay values for SCL to SDA are 00: 240ns 01: 280ns 10: 320ns 11: 360ns
			2	RW		Local Write Disable	Disable remote writes to local registers Setting the bit to a 1 prevents remote writes to local device registers from across the control channel. It prevents writes to the Serializer registers from an I2C master attached to the Deserializer. Setting this bit does not affect remote access to I2C slaves at the Serializer
			1	RW		I2C Bus Timer Speedup	Speed up I2C bus watchdog timer 1: Watchdog timer expires after ~50 ms. 0: Watchdog Timer expires after ~1 s
			0	RW		I2C Bus timer Disable	Disable I2C bus watchdog timer When the I2C watchdog timer may be used to detect when the I2C bus is free or hung up following an invalid termination of a transaction. If SDA is high and no signalling occurs for ~1 s, the I2C bus assumes to be free. If SDA is low and no signaling occurs, the device attempts to clear the bus by driving 9 clocks on SCL

**Register Maps (continued)**
**Table 6. Serial Control Bus Registers (continued)**

ADD (dec)	ADD (hex)	REGISTER NAME	Bit(s)	REGISTER TYPE	DEFAULT (hex)	FUNCTION	DESCRIPTION
6	0x06	DES ID	7:1	RW	0x00	DES Device ID	7-bit Deserializer Device ID Configures the I2C Slave ID of the remote Deserializer. A value of 0 in this field disables I2C access to the remote Deserializer. This field is automatically configured by the Bidirectional Control Channel once RX Lock has been detected. Software may overwrite this value, but should also assert the FREEZE DEVICE ID bit to prevent overwriting by the Bidirectional Control Channel.
			0	RW		Device ID Frozen	Freeze Deserializer Device ID Prevents autoloading of the Deserializer Device ID by the Bidirectional Control Channel. The ID will be frozen at the value written.
7	0x07	Slave ID	7:1	RW	0x00	Slave Device ID	7-bit Remote Slave Device ID Configures the physical I2C address of the remote I2C Slave device attached to the remote Deserializer. If an I2C transaction is addressed to the Slave Device Alias ID, the transaction will be remapped to this address before passing the transaction across the Bidirectional Control Channel to the Deserializer
			0				<b>Reserved</b>
8	0x08	Slave Alias	7:1	RW	0x00	Slave Device Alias ID	7-bit Remote Slave Device Alias ID Assigns an Alias ID to an I2C Slave device attached to the remote Deserializer. The transaction will be remapped to the address specified in the Slave ID register. A value of 0 in this field disables access to the remote I2C Slave.
			0				<b>Reserved</b>
10	0x0A	CRC Errors	7:0	R	0x00	CRC Error LSB	Number of back channel CRC errors – 8 least significant bits
11	0x0B		7:0	R	0x00	CRC Error MSB	Number of back channel CRC errors – 8 most significant bits
12	0x0C	General Status	7:4		0x00		<b>Reserved</b>
			3	R		BIST CRC Error	Back channel CRC error during BIST communication with Deserializer. The bit is cleared upon loss of link, restart of BIST, or assertion of CRC ERROR RESET in register 0x04.
			2	R		PCLK Detect	PCLK Status 1: Valid PCLK detected 0: Valid PCLK not detected
			1	R		DES Error	Back channel CRC error during communication with Deserializer. The bit is cleared upon loss of link or assertion of CRC ERROR RESET in register 0x04.
			0	R		LINK Detect	LINK Status 1: Cable link detected 0: Cable link not detected (Fault Condition)

Register Maps (continued)

Table 6. Serial Control Bus Registers (continued)

ADD (dec)	ADD (hex)	REGISTER NAME	Bit(s)	REGISTER TYPE	DEFAULT (hex)	FUNCTION	DESCRIPTION
13	0x0D	Revision ID and GPIO0 Configuration	7:4	R	0xA0	Rev-ID	Revision ID: 1010 Production Device
			3	RW		GPIO0 Output Value	Local GPIO output value This value is output on the GPIO pin when the GPIO function is enabled, the local GPIO direction is Output, and remote GPIO control is disabled.
			2	RW		GPIO0 Remote Enable	Remote GPIO control 1: Enable GPIO control from remote Deserializer. The GPIO pin will be an output, and the value is received from the remote Deserializer. 0: Disable GPIO control from remote Deserializer.
			1	RW		GPIO0 Direction	Local GPIO Direction 1: Input 0: Output
			0	RW		GPIO0 Enable	GPIO function enable 1: Enable GPIO operation 0: Enable normal operation
14	0x0E	GPIO2 and GPIO1 Configurations	7	RW	0x0	GPIO2 Output Value	Local GPIO output value This value is output on the GPIO pin when the GPIO function is enabled, the local GPIO direction is Output, and remote GPIO control is disabled.
			6	RW		GPIO2 Remote Enable	Remote GPIO control 1: Enable GPIO control from remote Deserializer. The GPIO pin will be an output, and the value is received from the remote Deserializer. 0: Disable GPIO control from remote Deserializer.
			5	RW		GPIO2 Direction	Local GPIO Direction 1: Input 0: Output
			4	RW		GPIO2 Enable	GPIO function enable 1: Enable GPIO operation 0: Enable normal operation
			3	RW		GPIO1 Output Value	Local GPIO output value This value is output on the GPIO pin when the GPIO function is enabled, the local GPIO direction is Output, and remote GPIO control is disabled.
			2	RW		GPIO1 Remote Enable	Remote GPIO control 1: Enable GPIO control from remote Deserializer. The GPIO pin will be an output, and the value is received from the remote Deserializer. 0: Disable GPIO control from remote Deserializer.
			1	RW		GPIO1 Direction	Local GPIO Direction 1: Input 0: Output
			0	RW		GPIO1 Enable	GPIO function enable 1: Enable GPIO operation 0: Enable normal operation

**Register Maps (continued)**
**Table 6. Serial Control Bus Registers (continued)**

ADD (dec)	ADD (hex)	REGISTER NAME	Bit(s)	REGISTER TYPE	DEFAULT (hex)	FUNCTION	DESCRIPTION
15	0x0F	GPO_REG4 and GPIO3 Configurations	7	RW	0x00	GPO_REG 4 Output Value	Local GPO_REG4 output value This value is output on the GPO pin when the GPO function is enabled. (The local GPO direction is Output, and remote GPO control is disabled)
			6:5			<b>Reserved</b>	
			4	RW		GPO_REG 4 Enable	GPO_REG4 function enable 1: Enable GPO operation 0: Enable normal operation
			3	RW		GPIO3 Output Value	Local GPIO output value This value is output on the GPIO pin when the GPIO function is enabled, the local GPIO direction is Output, and remote GPIO control is disabled.
			2	RW		GPIO3 Remote Enable	Remote GPIO control 1: Enable GPIO control from remote Deserializer. The GPIO pin will be an output, and the value is received from the remote Deserializer. 0: Disable GPIO control from remote Deserializer.
			1	RW		GPIO3 Direction	Local GPIO Direction 1: Input 0: Output
			0	RW		GPIO3 Enable	GPIO function enable 1: Enable GPIO operation 0: Enable normal operation
			16	0x10		GPO_REG6 and GPO_REG5 Configurations	7
6:5		<b>Reserved</b>					
4	RW	GPO_REG 6 Enable			GPO_REG6 function enable 1: Enable GPO operation 0: Enable normal operation		
3	RW	GPO_REG 5 Output Value			Local GPO_REG5 output value This value is output on the GPO pin when the GPO function is enabled, the local GPO direction is Output, and remote GPO control is disabled.		
2:1		<b>Reserved</b>					
0	RW	GPO_REG 5 Enable			GPO_REG5 function enable 1: Enable GPO operation 0: Enable normal operation		

**Register Maps (continued)**
**Table 6. Serial Control Bus Registers (continued)**

ADD (dec)	ADD (hex)	REGISTER NAME	Bit(s)	REGISTER TYPE	DEFAULT (hex)	FUNCTION	DESCRIPTION
17	0x11	GPO_REG8 and GPO_REG7 Configurations	7	RW	0x00	GPO_REG8 Output Value	Local GPO_REG8 output value This value is output on the GPO pin when the GPO function is enabled. (The local GPO direction is Output, and remote GPO control is disabled)
			6:5			<b>Reserved</b>	
			4	RW		GPO_REG8 Enable	GPO_REG8 function enable 1: Enable GPO operation 0: Enable normal operation
			3	RW		GPO_REG7 Output Value	Local GPO_REG7 output value This value is output on the GPO pin when the GPO function is enabled, the local GPO direction is Output, and remote GPO control is disabled.
			2:1			<b>Reserved</b>	
			0	RW		GPO_REG7 Enable	GPO_REG7 function enable 1: Enable GPO operation 0: Enable normal operation
18	0x12	Data Path Control	7		0x00		<b>Reserved</b>
			6	RW		Pass RGB	Setting this bit causes RGB data to be sent independent of DE. It allows operation in systems which may not use DE to frame video data or send other data when DE is de-asserted. Note that setting this bit prevents HDCP operation and blocks packetized audio. This bit does not need to be set in Backwards Compatible mode 1: Pass RGB independent of DE 0: Normal operation (DE gates RGB data transmission - RGB data is transmitted only when DE is active)
			5	RW		DE Polarity	The bit indicates the polarity of the Data Enable (DE) signal. 1: DE is inverted (active low, idle high) 0: DE is positive (active high, idle low)
			4	RW		I2S Repeater Regeneration	I2S Repeater Regeneration 1: Repeater regenerate I2S from I2S pins 0: Repeater pass through I2S from video pins
			3	RW		I2S Channel B Enable Override	I2S Channel B Enable 1: Set I2S Channel B Enable from reg_0x12[0] 0: Set I2S Channel B Enable from MODE_SEL pin
			2	RW		18-bit Video Select	18-bit video select 1: Select 18-bit video mode Note: use of GPIO(s) on unused inputs must be enabled by register. 0: Select 24-bit video mode
			1	RW		I2S Transport Select	I2S Transport Mode Select 1: Enable I2S Data Forward Channel Frame Transport 0: Enable I2S Data Island Transport
			0	RW		I2S Channel B Enable	I2S Channel B Enable 1: Enable I2S Channel B on B1 input 0: I2S Channel B disabled

**Register Maps (continued)**
**Table 6. Serial Control Bus Registers (continued)**

ADD (dec)	ADD (hex)	REGISTER NAME	Bit(s)	REGISTER TYPE	DEFAULT (hex)	FUNCTION	DESCRIPTION
19	0x13	Mode Status	7:5		0x10		<b>Reserved</b>
			4	R		MODE_SEL	MODE_SEL Status 1: MODE_SEL decode circuit is completed 0: MODE_SEL decode circuit is not completed
			3	R		Low Frequency Mode	Low Frequency Mode Status 1: Low frequency (5 - <15 MHz) 0: Normal frequency (15 - 85 MHz)
			2	R		Repeater Mode	Repeater Mode Status 1: Repeater mode <i>ON</i> 0: Repeater Mode <i>OFF</i>
			1	R		Backward Compatible Mode	Backward Compatible Mode Status 1: Backward compatible <i>ON</i> 0: Backward compatible <i>OFF</i>
			0	R		I2S Channel B Mode	I2S Channel B Mode Status 1: I2S Channel B <i>ON</i> , 18-bit RGB mode with I2S_DB enabled 0: I2S Channel B <i>OFF</i> ; normal 24-bit RGB mode
20	0x14	Oscillator Clock Source and BIST Status	7:3		0x00		<b>Reserved</b>
			2:1	RW		OSC Clock Source	OSC Clock Source (When LFMODE = 1, Oscillator = 12.5MHz ONLY) 00: External Pixel Clock 01: 33 MHz Oscillator 10: Reserved 11: 25 MHz Oscillator
			0	R		BIST Enable Status	BIST status 1: Enabled 0: Disabled
22	0x16	BCC Watchdog Control	7:1	RW	0xFE	Timer Value	The watchdog timer allows termination of a control channel transaction if it fails to complete within a programmed amount of time. This field sets the Bidirectional Control Channel Watchdog Timeout value in units of 2 ms. This field should not be set to 0
			0	RW		Timer Control	Disable Bidirectional Control Channel Watchdog Timer 1: Disables BCC Watchdog Timer operation 0: Enables BCC Watchdog Timer operation
23	0x17	I2C Control	7	RW	0x5E	I2C Pass All	I2C Control 1: Enable Forward Control Channel pass-through of all I2C accesses to I2C Slave IDs that do not match the Serializer I2C Slave ID. 0: Enable Forward Control Channel pass-through only of I2C accesses to I2C Slave IDs matching either the remote Deserializer Slave ID or the remote Slave ID.
			6				<b>Reserved</b>
			5:4	RW		SDA Hold Time	Internal SDA Hold Time Configures the amount of internal hold time provided for the SDA input relative to the SCL input. Units are 40 ns
			3:0	RW		I2C Filter Depth	Configures the maximum width of glitch pulses on the SCL and SDA inputs that will be rejected. Units are 5 ns

Register Maps (continued)

Table 6. Serial Control Bus Registers (continued)

ADD (dec)	ADD (hex)	REGISTER NAME	Bit(s)	REGISTER TYPE	DEFAULT (hex)	FUNCTION	DESCRIPTION
24	0x18	SCL High Time	7:0	RW	0xA1	SCL HIGH Time	I2C Master SCL High Time This field configures the high pulse width of the SCL output when the Serializer is the Master on the local I2C bus. Units are 40 ns for the nominal oscillator clock frequency. The default value is set to provide a minimum 5us SCL high time with the internal oscillator clock running at 32.5MHz rather than the nominal 25MHz.
25	0x19	SCL Low Time	7:0	RW	0xA5	SCL LOW Time	I2C SCL Low Time This field configures the low pulse width of the SCL output when the Serializer is the Master on the local I2C bus. This value is also used as the SDA setup time by the I2C Slave for providing data prior to releasing SCL during accesses over the Bidirectional Control Channel. Units are 40 ns for the nominal oscillator clock frequency. The default value is set to provide a minimum 5us SCL low time with the internal oscillator clock running at 32.5MHz rather than the nominal 25MHz.
27	0x1B	BIST BC Error	7:0	R	0x00	BIST Back Channel CRC Error Counter	BIST Mode Back Channel CRC Error Counter This error counter is active only in the BIST mode. It clears itself at the start of the BIST run.
100	0x64	Pattern Generator Control	7:4	RW	0x10	Pattern Generator Select	Fixed Pattern Select This field selects the pattern to output when in Fixed Pattern Mode. Scaled patterns are evenly distributed across the horizontal or vertical active regions. This field is ignored when Auto-Scrolling Mode is enabled. The following table shows the color selections in non-inverted followed by inverted color mode 0000: Reserved 0001: White/Black 0010: Black/White 0011: Red/Cyan 0100: Green/Magenta 0101: Blue/Yellow 0110: Horizontally Scaled Black to White/White to Black 0111: Horizontally Scaled Black to Red/Cyan to White 1000: Horizontally Scaled Black to Green/Magenta to White 1001: Horizontally Scaled Black to Blue/Yellow to White 1010: Vertically Scaled Black to White/White to Black 1011: Vertically Scaled Black to Red/Cyan to White 1100: Vertically Scaled Black to Green/Magenta to White 1101: Vertically Scaled Black to Blue/Yellow to White 1110: Custom color (or its inversion) configured in PGRS, PGGs, PGBs registers 1111: Reserved
			3:1				<b>Reserved</b>
			0	RW		Pattern Generator Enable	1: Enable Pattern Generator 0: Disable Pattern Generator

**Register Maps (continued)**
**Table 6. Serial Control Bus Registers (continued)**

ADD (dec)	ADD (hex)	REGISTER NAME	Bit(s)	REGISTER TYPE	DEFAULT (hex)	FUNCTION	DESCRIPTION
101	0x65	Pattern Generator Configuration	7:5		0x00		<b>Reserved</b>
			4	RW		Pattern Generator 18 Bits	18-bit Mode Select 1: Enable 18-bit color pattern generation. Scaled patterns will have 64 levels of brightness and the R, G, and B outputs use the six most significant color bits. 0: Enable 24-bit pattern generation. Scaled patterns use 256 levels of brightness.
			3	RW		Pattern Generator External Clock	Select External Clock Source 1: Selects the external pixel clock when using internal timing. 0: Selects the internal divided clock when using internal timing This bit has no effect in external timing mode (PATGEN_TSEL = 0).
			2	RW		Pattern Generator Timing Select	Timing Select Control 1: The Pattern Generator creates its own video timing as configured in the Pattern Generator Total Frame Size, Active Frame Size, Horizontal Sync Width, Vertical Sync Width, Horizontal Back Porch, Vertical Back Porch, and Sync Configuration registers. 0: the Pattern Generator uses external video timing from the pixel clock, Data Enable, Horizontal Sync, and Vertical Sync signals.
			1	RW		Pattern Generator Color Invert	Enable Inverted Color Patterns 1: Invert the color output. 0: Do not invert the color output.
			0	RW		Pattern Generator Auto-Scroll Enable	Auto-Scroll Enable: 1: The Pattern Generator will automatically move to the next enabled pattern after the number of frames specified in the Pattern Generator Frame Time (PGFT) register. 0: The Pattern Generator retains the current pattern.
102	0x66	Pattern Generator Indirect Address	7:0	RW	0x00	Indirect Address	This 8-bit field sets the indirect address for accesses to indirectly-mapped registers. It should be written prior to reading or writing the Pattern Generator Indirect Data register. See AN-2198 ( <a href="#">SNLA132</a> )
103	0x67	Pattern Generator Indirect Data	7:0	RW	0x00	Indirect Data	When writing to indirect registers, this register contains the data to be written. When reading from indirect registers, this register contains the read back value. See AN-2198 ( <a href="#">SNLA132</a> )
128	0x80	RX_BKSV0	7:0	R	0x00	RX BKSV0	BKSV0: Value of byte 0 of the Deserializer KSV
129	0x81	RX_BKSV1	7:0	R	0x00	RX BKSV1	BKSV1: Value of byte 1 of the Deserializer KSV
130	0x82	RX_BKSV2	7:0	R	0x00	RX BKSV2	BKSV2: Value of byte 2 of the Deserializer KSV
131	0x83	RX_BKSV3	7:0	R	0x00	RX BKSV3	BKSV3: Value of byte 3 of the Deserializer KSV
132	0x84	RX_BKSV4	7:0	R	0x00	RX BKSV4	BKSV4: Value of byte 4 of the Deserializer KSV
144	0x90	TX_KSV0	7:0	R	0x00	TX KSV0	KSV0: Value of byte 0 of the Serializer KSV
145	0x91	TX_KSV1	7:0	R	0x00	TX KSV1	KSV1: Value of byte 1 of the Serializer KSV
146	0x92	TX_KSV2	7:0	R	0x00	TX KSV2	KSV2: Value of byte 2 of the Serializer KSV
147	0x93	TX_KSV3	7:0	R	0x00	TX KSV3	KSV3: Value of byte 3 of the Serializer KSV
148	0x94	TX_KSV4	7:0	R	0x00	TX KSV4	KSV4: Value of byte 4 of the Serializer KSV

**Register Maps (continued)**
**Table 6. Serial Control Bus Registers (continued)**

ADD (dec)	ADD (hex)	REGISTER NAME	Bit(s)	REGISTER TYPE	DEFAULT (hex)	FUNCTION	DESCRIPTION
160	0xA0	RX BCAPS	7		0x13		<b>Reserved</b>
			6	R		Repeater	Indicates if the attached Receiver supports downstream connections. This bit is valid once the Bksv is ready as indicated by the BKSV_RDY bit in the HDCP
			5	R		KSV FIFO	KSV FIFO Ready Indicates the receiver has built the list of attached KSVs and computed the verification value
			4	R		Fast I2C	Fast I2C: The HDCP Receiver supports fast I2C. Since the I2C is embedded in the serial data, this bit is not relevant
			3:2				<b>Reserved</b>
			1	R		Features	HDCP v1.1_Features The HDCP Receiver supports the Enhanced Encryption Status Signaling (EESS), Advance Cipher, and Enhanced Link Verification options.
			0	R		Fast Re-auth	The HDCP Receiver is capable of receiving (unencrypted) video signal during the session re-authentication.
161	0xA1	RX BSTATUS0	7	R	0x00	Max Devices	Maximum Devices Exceeded: Indicates a topology error was detected. Indicates the number of downstream devices has exceeded the depth of the Repeater's KSV FIFO
			6:0	R		Device Count	Total number of attached downstream device. For a Repeater, this will indicate the number of downstream devices, not including the Repeater. For an HDCP Receiver that is not also a Repeater, this field will be 0
162	0xA2	RX BSTATUS1	7:4		0x00		<b>Reserved</b>
			3	R		Max Cascade	Maximum Cascade Exceeded: Indicates a topology error was detected. Indicates that more than seven levels of repeaters have been cascaded together
			2:0	R		Cascade Depth	Indicates the number of attached levels of devices for the Repeater
163	0xA3	KSV FIFO	7:0	R	0x00	KSV FIFO	KSV FIFO Each read of the KSV FIFO returns one byte of the KSV FIFO list composed by the downstream Receiver.

**Register Maps (continued)**
**Table 6. Serial Control Bus Registers (continued)**

ADD (dec)	ADD (hex)	REGISTER NAME	Bit(s)	REGISTER TYPE	DEFAULT (hex)	FUNCTION	DESCRIPTION
192	0xC0	HDCP DBG	7:4		0x00		<i>Reserved</i>
			3	RW		RGB CHKSUM	Enable RGB video line checksum Enables sending of ones-complement checksum for each 8-bit RBG data channel following end of each video data line
			2	RW		Fast LV	Fast Link Verification HDCP periodically verifies that the HDCP Receiver is correctly synchronized. Setting this bit will increase the rate at which synchronization is verified. When set to a 1, P <sub>j</sub> is computed every 2 frames and R <sub>i</sub> is computed every 16 frames. When set to a 0, P <sub>j</sub> is computed every 16 frames and R <sub>i</sub> is computed every 128 frames.
			1	RW		TMR Speed Up	Timer Speedup Speed up HDCP authentication timers.
			0	RW		HDCP I2C Fast	HDCP I2C Fast Mode Enable Setting this bit to a 1 will enable the HDCP I2C Master in the HDCP Receiver to operate with Fast mode timing. If set to a 0, the I2C Master will operate with Standard mode timing. This bit is mirrored in the IND_STS register

**Register Maps (continued)**
**Table 6. Serial Control Bus Registers (continued)**

ADD (dec)	ADD (hex)	REGISTER NAME	Bit(s)	REGISTER TYPE	DEFAULT (hex)	FUNCTION	DESCRIPTION
194	0xC2	HDCP CFG	7	RW	0x80	ENH LV	Enable Enhanced Link Verification Allows checking of the encryption Pj value on every 16th frame 1: Enhanced Link Verification enabled 0: Enhanced Link Verification disabled
			6	RW		HDCP EESS	Enables Enhanced Encryption Status Signaling (EESS) instead of the Original Encryption Status Signaling (OESS) 1: EESS mode enabled 0: OESS mode enabled
			5	RW		TX RPTR	Transmit Repeater Enable Enables the transmitter to act as a repeater. In this mode, the HDCP Transmitter incorporates the additional authentication steps required of an HDCP Repeater. 1: Transmit Repeater mode enabled 0: Transmit Repeater mode disabled
			4:3	RW		ENC Mode	Encryption Control Mode Determines mode for controlling whether encryption is required for video frames 00: Enc_Authenticated 01: Enc_Reg_Control 10: Enc_Always 11: Enc_InBand_Control (per frame) If the Repeater strap option is set at power-up, Enc_InBand_Control (ENC_MODE == 11) will be selected. Otherwise, the default will be Enc_Authenticated mode (ENC_MODE == 00).
			2	RW		Wait	Enable 100ms Wait The HDCP 1.3 specification allows for a 100ms wait to allow the HDCP Receiver to compute the initial encryption values. The FPD-Link III implementation ensures that the Receiver will complete the computations before the HDCP Transmitter. Thus the timer is unnecessary. To enable the 100ms timer, set this bit to a 1.
			1	RW		RX DET SEL	RX Detect Select Controls assertion of the Receiver Detect Interrupt. If set to 0, the Receiver Detect Interrupt will be asserted on detection of an FPD-Link III Receiver. If set to 1, the Receiver Detect Interrupt will also require a receive lock indication from the receiver.
			0	RW		HDCP AV MUTE	Enable AV MUTE Setting this bit to a 1 will initiate AV MUTE operation. The transmitter will ignore encryption status controls while in this state. If this bit is set to a 0, normal operation resumes. This bit may only be set if the HDCP_EESS bit is also set.

**Register Maps (continued)**
**Table 6. Serial Control Bus Registers (continued)**

ADD (dec)	ADD (hex)	REGISTER NAME	Bit(s)	REGISTER TYPE	DEFAULT (hex)	FUNCTION	DESCRIPTION
195	0xC3	HDCP CTL	7	RW	0x00	HDCP RST	HDCP Reset Setting this bit will reset the HDCP transmitter and disable HDCP authentication. This bit is self-clearing.
			6				<b>Reserved</b>
			5	RW		KSV List Valid	The controller sets this bit after validating the Repeater's KSV List against the Key revocation list. This allows completion of the Authentication process. This bit is self-clearing
			4	RW		KSV Valid	The controller sets this bit after validating the Receiver's KSV against the Key revocation list. This allows continuation of the Authentication process. This bit will be cleared upon assertion of the KSV_RDY flag in the HDCP_STS register. Setting this bit to a 0 will have no effect
			3	RW		HDCP ENC DIS	HDCP Encrypt Disable Disables HDCP encryption. Setting this bit to a 1 will cause video data to be sent without encryption. Authentication status will be maintained. This bit is self-clearing
			2	RW		HDCP ENC EN	HDCP Encrypt Enable Enables HDCP encryption. When set, if the device is authenticated, encrypted data will be sent. If device is not authenticated, a blue screen will be sent. Encryption should always be enabled when video data requiring content protection is being supplied to the transmitter. When this bit is not set, video data will be sent without encryption. Note that when CFG_ENC_MODE is set to Enc_Always, this bit will be read only with a value of 1
			1	RW		HDCP DIS	HDCP Disable Disables HDCP authentication. Setting this bit to a 1 will disable the HDCP authentication. This bit is self-clearing
			0	RW		HDCP EN	HDCP Enable/Restart Enables HDCP authentication. If HDCP is already enabled, setting this bit to a 1 will restart authentication. Setting this bit to a 0 will have no effect. A register read will return the current HDCP enabled status

**Register Maps (continued)**
**Table 6. Serial Control Bus Registers (continued)**

ADD (dec)	ADD (hex)	REGISTER NAME	Bit(s)	REGISTER TYPE	DEFAULT (hex)	FUNCTION	DESCRIPTION
196	0xC4	HDCP STS	7	R	0x00	I2C ERR DET	HDCP I2C Error Detected This bit indicates an error was detected on the embedded communications channel with the HDCP Receiver. Setting of this bit might indicate that a problem exists on the link between the HDCP Transmitter and HDCP Receiver. This bit will be cleared on read
			6	R		RX INT	RX Interrupt Status of the RX Interrupt signal. The signal is received from the attached HDCP Receiver and is the status on the INTB_IN pin of the HDCP Receiver. The signal is active low, a 0 indicates an interrupt condition
			5	R		RX Lock DET	Receiver Lock Detect This bit indicates that the downstream Receiver has indicated Receive Lock to incoming serial data
			4	R		DOWN HPD	Hot Plug Detect This bit indicates the local device or a downstream repeater has reported a Hot Plug event, indicating addition of a new receiver. This bit will be cleared on read
			3	R		RX DET	Receiver Detect This bit indicates that a downstream Receiver has been detected
			2	R		KSV LIST RDY	HDCP Repeater KSV List Ready This bit indicates that the Receiver KSV list has been read and is available in the KSV_FIFO registers. The device will wait for the controller to set the KSV_LIST_VALID bit in the HDCP_CTL register before continuing. This bit will be cleared once the controller sets the KSV_LIST_VALID bit.
			1	R		KSV RDY	HDCP Receiver KSV Ready This bit indicates that the Receiver KSV has been read and is available in the HDCP_BKSV registers. If the device is not a Repeater, it will wait for the controller to set the KSV_VALID bit in the HDCP_CTL register before continuing. This bit will be cleared once the controller sets the KSV_VALID bit. The bit will also be cleared if authentication fails.
			0	R		AUTHED	HDCP Authenticated Indicates the HDCP authentication has completed successfully. The controller may now send video data requiring content protection. This bit will be cleared if authentication is lost or if the controller restarts authentication

**Register Maps (continued)**
**Table 6. Serial Control Bus Registers (continued)**

ADD (dec)	ADD (hex)	REGISTER NAME	Bit(s)	REGISTER TYPE	DEFAULT (hex)	FUNCTION	DESCRIPTION
198	0xC6	HDCP ICR	7	RW	0x00	IE IND ACC	Interrupt on Indirect Access Complete Enables interrupt on completion of Indirect Register Access
			6	RW		IE RXDET INT	Interrupt on Receiver Detect Enables interrupt on detection of a downstream Receiver. If HDCP_CFG:RX_DET_SEL is set to a 1, the interrupt will wait for Receiver Lock Detect.
			5	RW		IS_RX_INT	Interrupt on Receiver interrupt Enables interrupt on indication from the HDCP Receiver. Allows propagation of interrupts from downstream devices
			4	RW		IE LIST RDY	Interrupt on KSV List Ready Enables interrupt on KSV List Ready
			3	RW		IE KSV RDY	Interrupt on KSV Ready Enables interrupt on KSV Ready
			2	RW		IE AUTH FAIL	Interrupt on Authentication Failure Enables interrupt on authentication failure or loss of authentication
			1	RW		IE AUTH PASS	Interrupt on Authentication Pass Enables interrupt on successful completion of authentication
			0	RW		INT Enable	Global Interrupt Enable Enables interrupt on the interrupt signal to the controller.
199	0xC7	HDCP ISR	7	R	0x00	IS IND ACC	Interrupt on Indirect Access Complete Indirect Register Access has completed
			6	R		INT Detect	Interrupt on Receiver Detect interrupt A downstream receiver has been detected
			5	R		IS RX INT	Interrupt on Receiver interrupt Receiver has indicated an interrupt request from down-stream device
			4	R		IS LIST RDY	Interrupt on KSV List Ready The KSV list is ready for reading by the controller
			3	R		IS KSV RDY	Interrupt on KSV Ready The Receiver KSV is ready for reading by the controller
			2	R		IS AUTH FAIL	Interrupt on Authentication Failure Authentication failure or loss of authentication has occurred
			1	R		IS AUTH PASS	Interrupt on Authentication Pass Authentication has completed successfully
			0	R		INT	Global Interrupt Set if any enabled interrupt is indicated
240	0xF0	HDCP TX ID	7:0	R	0x5F	ID0	First byte ID code, '_'
241	0xF1		7:0	R	0x55	ID1	Second byte of ID code, 'U'
242	0xF2		7:0	R	0x48	ID2	Third byte of ID code. Value will be either 'B' or 'H'. 'H' indicates an HDCP capable device
243	0xF3		7:0	R	0x39	ID3	Forth byte of ID code: '9'
244	0xF4		7:0	R	0x32	ID4	Fifth byte of ID code: '2'
245	0xF5		7:0	R	0x35	ID5	Sixth byte of ID code: '5'

## 8 Applications and Implementation

---

### NOTE

Information in the following applications sections is not part of the TI component specification, and TI does not warrant its accuracy or completeness. TI's customers are responsible for determining suitability of components for their purposes. Customers should validate and test their design implementation to confirm system functionality.

---

### 8.1 Application Information

The DS90UH925Q-Q1, in conjunction with the DS90UH926Q-Q1, is intended for interface between a HDCP compliant host (graphics processor) and a Display. It supports a 24-bit color depth (RGB888) and high definition (720p) digital video format. It can receive a three 8-bit RGB stream with a pixel rate up to 85 MHz together with three control bits (VS, HS and DE) and three I2S-bus audio stream with an audio sampling rate up to 192 kHz. The included HDCP 1.3 compliant cipher block allows the authentication of the DS90UH926Q-Q1, which decrypts both video and audio contents. The keys are pre-loaded by TI into Non-Volatile Memory (NVM) for maximum security.

### 8.2 Typical Application

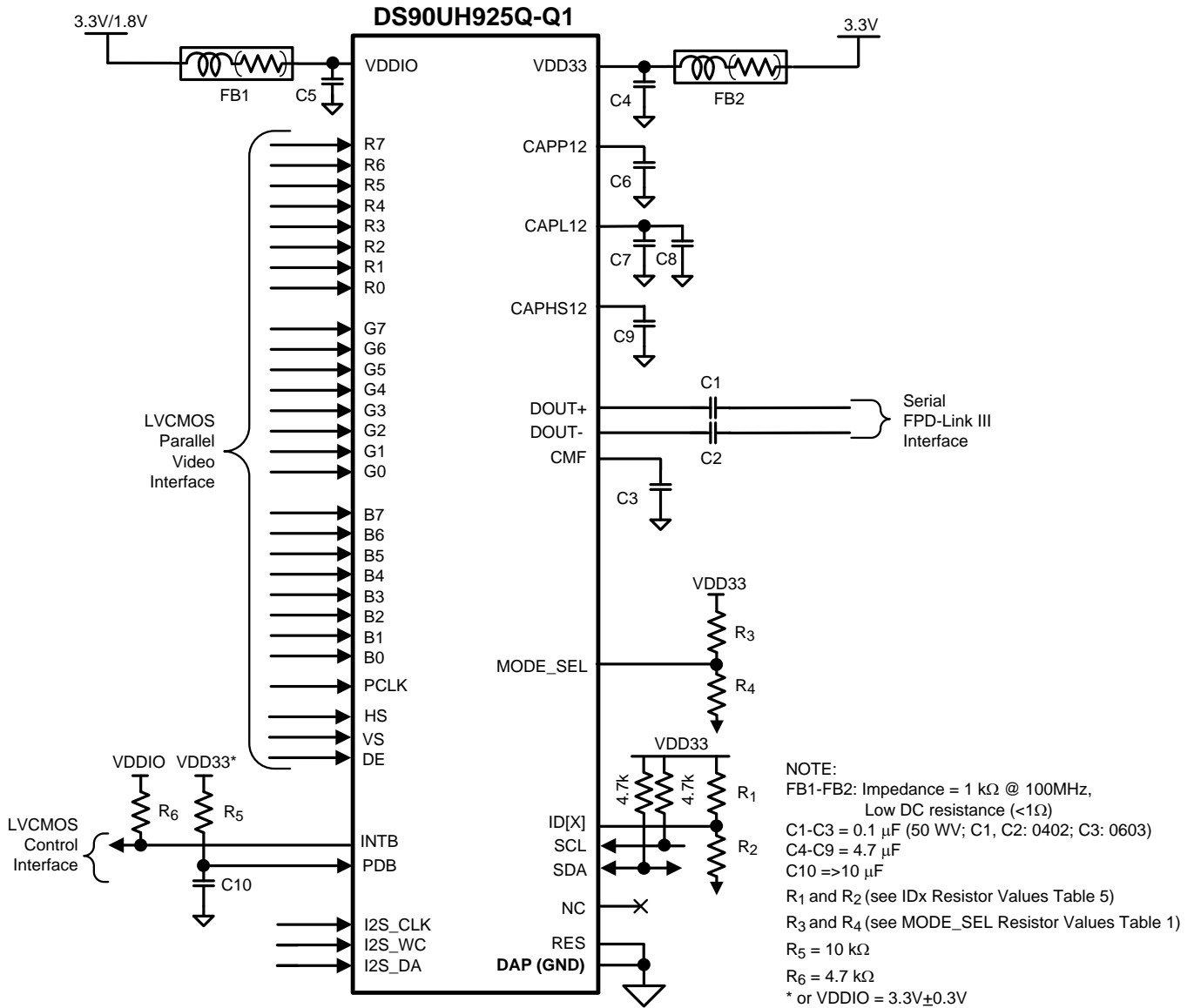

Figure 23. Typical Connection Diagram

Typical Application (continued)

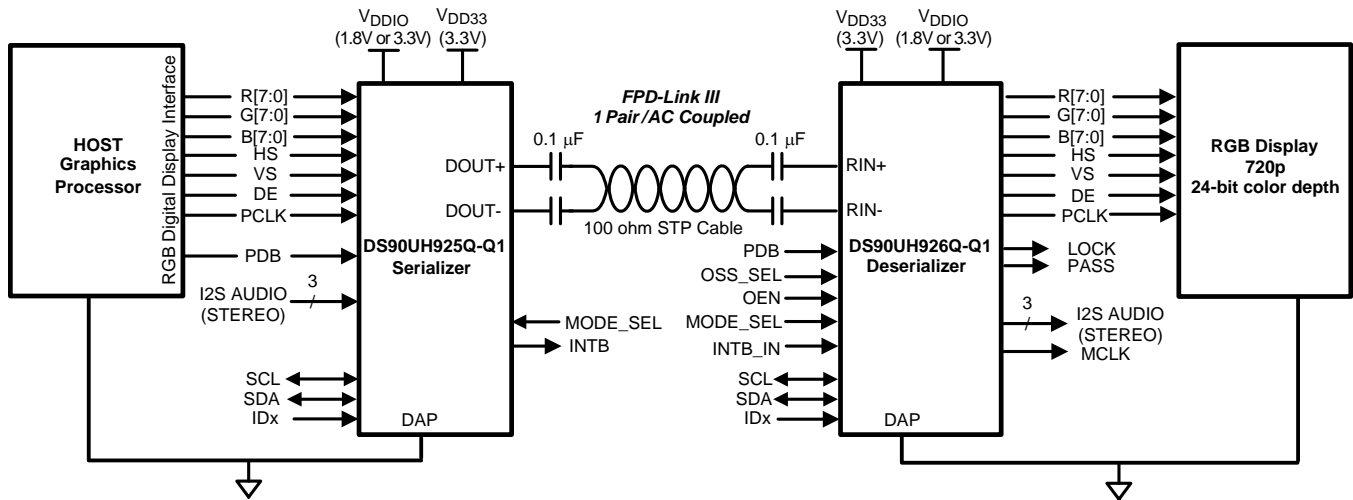

Figure 24. Typical Display System Diagram

8.2.1 Design Requirements

For the typical desing application, use the following as input parameters.

Table 7. Design Parameters

DESIGN PARAMETER	EXAMPLE VALUE
VDDIO	1.8 V or 3.3 V
VDD33	3.3 V
AC Coupling Capacitor for DOUT±	100 nF
PCLK Frequency	85 MHz

8.2.2 Detailed Design Procedure

Figure 23 shows a typical application of the DS90UH925Q-Q1 serializer for an 85 MHz 24-bit Color Display Application. The CML outputs must have an external 0.1 μF AC coupling capacitor on the high speed serial lines. The serializer has an internal termination. Bypass capacitors are placed near the power supply pins. At a minimum, six (6) 4.7μF capacitors (and two (2) additional 1μF capacitors should be used for local device bypassing. Ferrite beads are placed on the two (2) VDDs (V<sub>DD33</sub> and V<sub>DDIO</sub>) for effective noise suppression. The interface to the graphics source is with 3.3V LVCMOS levels, thus the V<sub>DDIO</sub> pin is connected to the 3.3 V rail. An RC delay is placed on the PDB signal to delay the enabling of the device until power is stable.

## 8.2.3 Application Curves

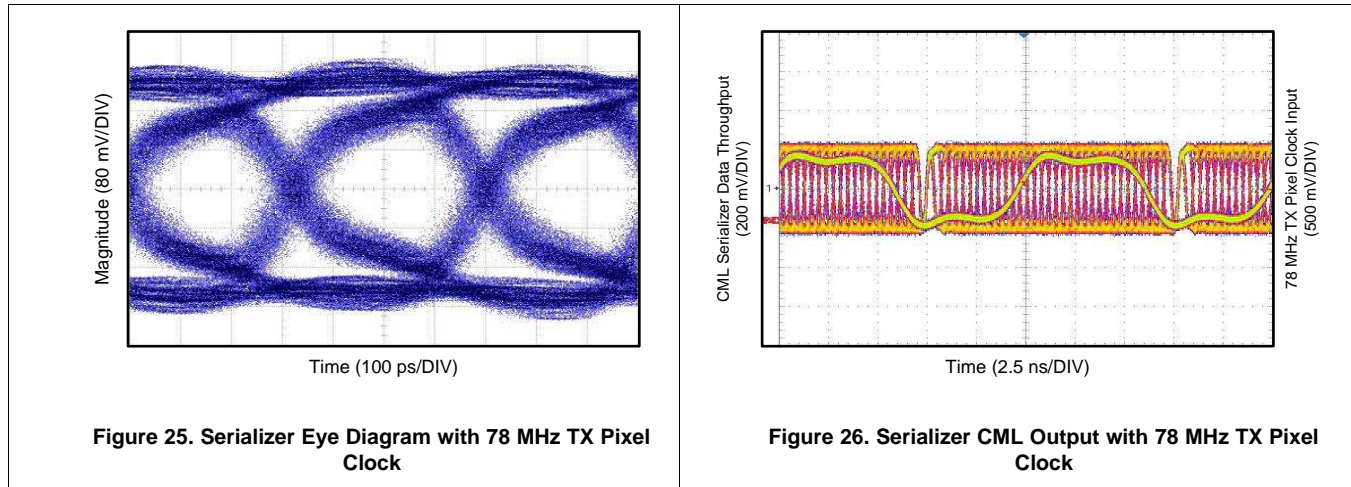

## 9 Power Supply Recommendations

This device is designed to operate from an input core voltage supply of 3.3V. Some devices provide separate power and ground pins for different portions of the circuit. This is done to isolate switching noise effects between different sections of the circuit. Separate planes on the PCB are typically not required. Pin description tables typically provide guidance on which circuit blocks are connected to which power pin pairs. In some cases, an external filter may be used to provide clean power to sensitive circuits such as PLLs.

### 9.1 Power Up Requirements and PDB Pin

The VDDs ( $V_{DD33}$  and  $V_{DDIO}$ ) supply ramp should be faster than 1.5 ms with a monotonic rise. A large capacitor on the PDB pin is needed to ensure PDB arrives after all the VDDs have settled to the recommended operating voltage. When PDB pin is pulled to  $V_{DDIO} = 3.0V$  to  $3.6V$  or  $V_{DD33}$ , it is recommended to use a 10 k $\Omega$  pull-up and a >10  $\mu F$  cap to GND to delay the PDB input signal.

All inputs must not be driven until  $V_{DD33}$  and  $V_{DDIO}$  has reached its steady state value.

### 9.2 CML Interconnect Guidelines

See AN-1108 ([SNLA008](#)) and AN-905 ([SNLA035](#)) for full details.

- Use 100 $\Omega$  coupled differential pairs
- Use the S/2S/3S rule in spacings
  - S = space between the pair
  - 2S = space between pairs
  - 3S = space to LVCMOS signal
- Minimize the number of Vias
- Use differential connectors when operating above 500 Mbps line speed
- Maintain balance of the traces
- Minimize skew within the pair

Additional general guidance can be found in the LVDS Owner's Manual - available in PDF format from the Texas Instruments web site at: [www.ti.com/lvds](http://www.ti.com/lvds).

## 10 Layout

### 10.1 Layout Guidelines

Circuit board layout and stack-up for the FPD-Link III devices should be designed to provide low-noise power feed to the device. Good layout practice will also separate high frequency or high-level inputs and outputs to minimize unwanted stray noise pickup, feedback and interference. Power system performance may be greatly improved by using thin dielectrics (2 to 4 mils) for power / ground sandwiches. This arrangement provides plane capacitance for the PCB power system with low-inductance parasitics, which has proven especially effective at high frequencies, and makes the value and placement of external bypass capacitors less critical. External bypass capacitors should include both RF ceramic and tantalum electrolytic types. RF capacitors may use values in the range of 0.01 uF to 0.1 uF. Tantalum capacitors may be in the 2.2 uF to 10 uF range. Voltage rating of the tantalum capacitors should be at least 5X the power supply voltage being used.

Surface mount capacitors are recommended due to their smaller parasitics. When using multiple capacitors per supply pin, locate the smaller value closer to the pin. A large bulk capacitor is recommended at the point of power entry. This is typically in the 50uF to 100uF range and will smooth low frequency switching noise. It is recommended to connect power and ground pins directly to the power and ground planes with bypass capacitors connected to the plane with via on both ends of the capacitor. Connecting power or ground pins to an external bypass capacitor will increase the inductance of the path.

A small body size X7R chip capacitor, such as 0603 or 0402, is recommended for external bypass. Its small body size reduces the parasitic inductance of the capacitor. The user must pay attention to the resonance frequency of these external bypass capacitors, usually in the range of 20-30 MHz. To provide effective bypassing, multiple capacitors are often used to achieve low impedance between the supply rails over the frequency of interest. At high frequency, it is also a common practice to use two vias from power and ground pins to the planes, reducing the impedance at high frequency.

Some devices provide separate power and ground pins for different portions of the circuit. This is done to isolate switching noise effects between different sections of the circuit. Separate planes on the PCB are typically not required. Pin Description tables typically provide guidance on which circuit blocks are connected to which power pin pairs. In some cases, an external filter may be used to provide clean power to sensitive circuits such as PLLs.

Use at least a four layer board with a power and ground plane. Locate LVCMOS signals away from the CML lines to prevent coupling from the LVCMOS lines to the CML lines. Closely-coupled differential lines of 100 Ohms are typically recommended for CML interconnect. The closely coupled lines help to ensure that coupled noise will appear as common-mode and thus is rejected by the receivers. The tightly coupled lines will also radiate less.

Information on the WQFN style package is provided in TI Application Note: AN-1187 ([SNOA401](#)).

### 10.2 Layout Example

Stencil parameters such as aperture area ratio and the fabrication process have a significant impact on paste deposition. Inspection of the stencil prior to placement of the WQFN package is highly recommended to improve board assembly yields. If the via and aperture openings are not carefully monitored, the solder may flow unevenly through the DAP. Stencil parameters for aperture opening and via locations are shown below:

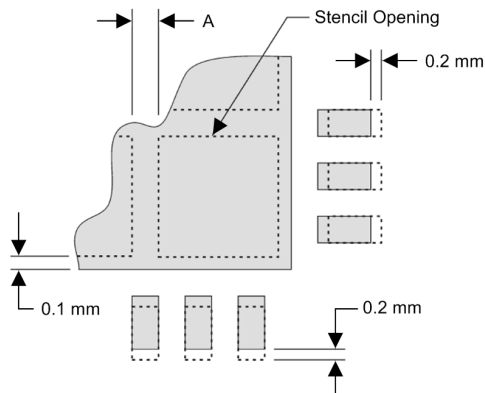

Figure 27. No Pullback WQFN, Single Row Reference Diagram

Table 8. No Pullback WQFN Stencil Aperture Summary

Device	Pin Count	MKT Dwg	PCB I/O Pad Size (mm)	PCB Pitch (mm)	PCB DAP size (mm)	Stencil I/O Aperture (mm)	Stencil DAP Aperture (mm)	Number of DAP Aperture Openings	Gap Between DAP Aperture (Dim A mm)
DS90UH925 Q-Q1	48	SQA48A	0.25 x 0.6	0.5	5.1 x 5.1	0.25 x 0.7	1.1 x 1.1	16	0.2

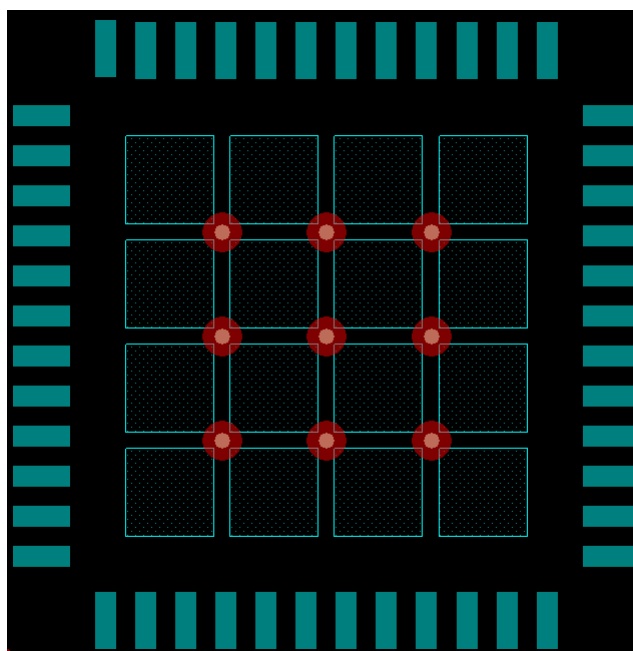

Figure 28. 48-Pin WQFN Stencil Example of Via and Opening Placement

Figure 29 shows the PCB layout example derived from the layout design of the DS90UH925QSEVB Evaluation Board. The graphic and layout description are used to determine both proper routing and proper solder techniques when designing the Serializer board.

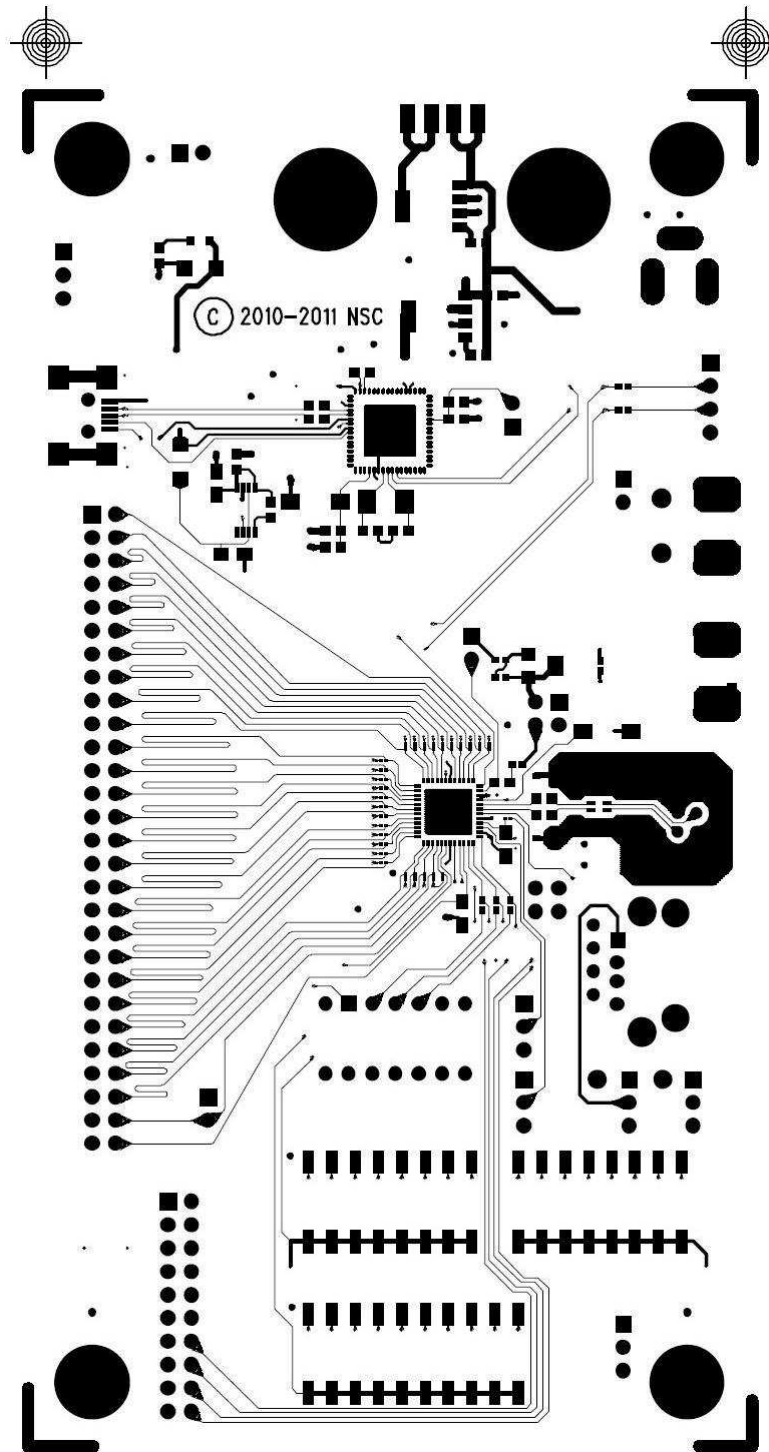

Figure 29. DS90UH925Q-Q1 Serializer Example Layout

## 11 Device and Documentation Support

### 11.1 Documentation Support

#### 11.1.1 Related Documentation

- AN-2198 Exploring the Internal Test Pattern Generation [SNLA132](#)
- AN-1108 Channel-Link PCB and Interconnect Design-In Guidelines [SNLA008](#)
- SCAN18245T Non-Inverting Transceiver with TRI-STATE Outputs [SNLA035](#)
- TI Interface Website [www.ti.com/lvds](http://www.ti.com/lvds)
- AN-1187 Leadless Leadframe Package (LLP) [SNOA401](#)
- Semiconductor and IC Package Thermal Metrics [SPRA953](#)

### 11.2 Trademarks

All trademarks are the property of their respective owners.

### 11.3 Electrostatic Discharge Caution



These devices have limited built-in ESD protection. The leads should be shorted together or the device placed in conductive foam during storage or handling to prevent electrostatic damage to the MOS gates.

### 11.4 Glossary

[SLYZ022](#) — *TI Glossary*.

This glossary lists and explains terms, acronyms, and definitions.

## 12 Mechanical, Packaging, and Orderable Information

The following pages include mechanical packaging and orderable information. This information is the most current data available for the designated devices. This data is subject to change without notice and revision of this document. For browser-based versions of this data sheet, refer to the left-hand navigation.



**PACKAGING INFORMATION**

Orderable Device	Status (1)	Package Type	Package Drawing	Pins	Package Qty	Eco Plan (2)	Lead/Ball Finish (6)	MSL Peak Temp (3)	Op Temp (°C)	Device Marking (4/5)	Samples
DS90UH925QSQ/NOPB	ACTIVE	WQFN	RHS	48	1000	Green (RoHS & no Sb/Br)	CU SN	Level-3-260C-168 HR	-40 to 105	UH925QSQ	<a href="#">Samples</a>
DS90UH925QSQE/NOPB	ACTIVE	WQFN	RHS	48	250	Green (RoHS & no Sb/Br)	CU SN	Level-3-260C-168 HR	-40 to 105	UH925QSQ	<a href="#">Samples</a>
DS90UH925QSQX/NOPB	ACTIVE	WQFN	RHS	48	2500	Green (RoHS & no Sb/Br)	CU SN	Level-3-260C-168 HR	-40 to 105	UH925QSQ	<a href="#">Samples</a>

(1) The marketing status values are defined as follows:

**ACTIVE:** Product device recommended for new designs.

**LIFEBUY:** TI has announced that the device will be discontinued, and a lifetime-buy period is in effect.

**NRND:** Not recommended for new designs. Device is in production to support existing customers, but TI does not recommend using this part in a new design.

**PREVIEW:** Device has been announced but is not in production. Samples may or may not be available.

**OBsolete:** TI has discontinued the production of the device.

(2) Eco Plan - The planned eco-friendly classification: Pb-Free (RoHS), Pb-Free (RoHS Exempt), or Green (RoHS & no Sb/Br) - please check <http://www.ti.com/productcontent> for the latest availability information and additional product content details.

**TBD:** The Pb-Free/Green conversion plan has not been defined.

**Pb-Free (RoHS):** TI's terms "Lead-Free" or "Pb-Free" mean semiconductor products that are compatible with the current RoHS requirements for all 6 substances, including the requirement that lead not exceed 0.1% by weight in homogeneous materials. Where designed to be soldered at high temperatures, TI Pb-Free products are suitable for use in specified lead-free processes.

**Pb-Free (RoHS Exempt):** This component has a RoHS exemption for either 1) lead-based flip-chip solder bumps used between the die and package, or 2) lead-based die adhesive used between the die and leadframe. The component is otherwise considered Pb-Free (RoHS compatible) as defined above.

**Green (RoHS & no Sb/Br):** TI defines "Green" to mean Pb-Free (RoHS compatible), and free of Bromine (Br) and Antimony (Sb) based flame retardants (Br or Sb do not exceed 0.1% by weight in homogeneous material)

(3) MSL, Peak Temp. - The Moisture Sensitivity Level rating according to the JEDEC industry standard classifications, and peak solder temperature.

(4) There may be additional marking, which relates to the logo, the lot trace code information, or the environmental category on the device.

(5) Multiple Device Markings will be inside parentheses. Only one Device Marking contained in parentheses and separated by a "~" will appear on a device. If a line is indented then it is a continuation of the previous line and the two combined represent the entire Device Marking for that device.

(6) Lead/Ball Finish - Orderable Devices may have multiple material finish options. Finish options are separated by a vertical ruled line. Lead/Ball Finish values may wrap to two lines if the finish value exceeds the maximum column width.

**Important Information and Disclaimer:** The information provided on this page represents TI's knowledge and belief as of the date that it is provided. TI bases its knowledge and belief on information provided by third parties, and makes no representation or warranty as to the accuracy of such information. Efforts are underway to better integrate information from third parties. TI has taken and

continues to take reasonable steps to provide representative and accurate information but may not have conducted destructive testing or chemical analysis on incoming materials and chemicals. TI and TI suppliers consider certain information to be proprietary, and thus CAS numbers and other limited information may not be available for release.

In no event shall TI's liability arising out of such information exceed the total purchase price of the TI part(s) at issue in this document sold by TI to Customer on an annual basis.

**TAPE AND REEL INFORMATION**

**QUADRANT ASSIGNMENTS FOR PIN 1 ORIENTATION IN TAPE**

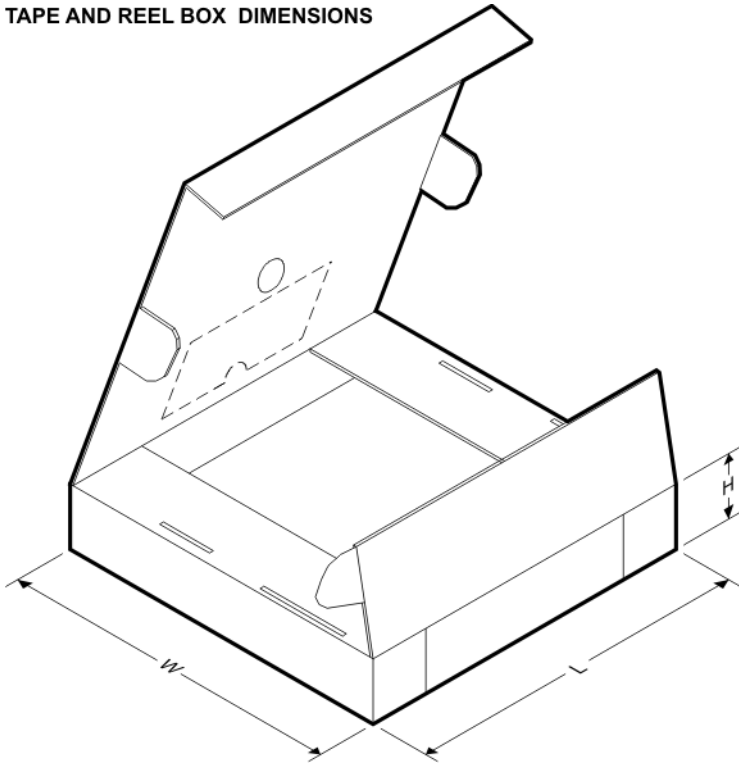

\*All dimensions are nominal

Device	Package Type	Package Drawing	Pins	SPQ	Reel Diameter (mm)	Reel Width W1 (mm)	A0 (mm)	B0 (mm)	K0 (mm)	P1 (mm)	W (mm)	Pin1 Quadrant
DS90UH925QSQ/NOPB	WQFN	RHS	48	1000	330.0	16.4	7.3	7.3	1.3	12.0	16.0	Q1
DS90UH925QSQE/NOPB	WQFN	RHS	48	250	178.0	16.4	7.3	7.3	1.3	12.0	16.0	Q1
DS90UH925QSQX/NOPB	WQFN	RHS	48	2500	330.0	16.4	7.3	7.3	1.3	12.0	16.0	Q1

**TAPE AND REEL BOX DIMENSIONS**

\*All dimensions are nominal

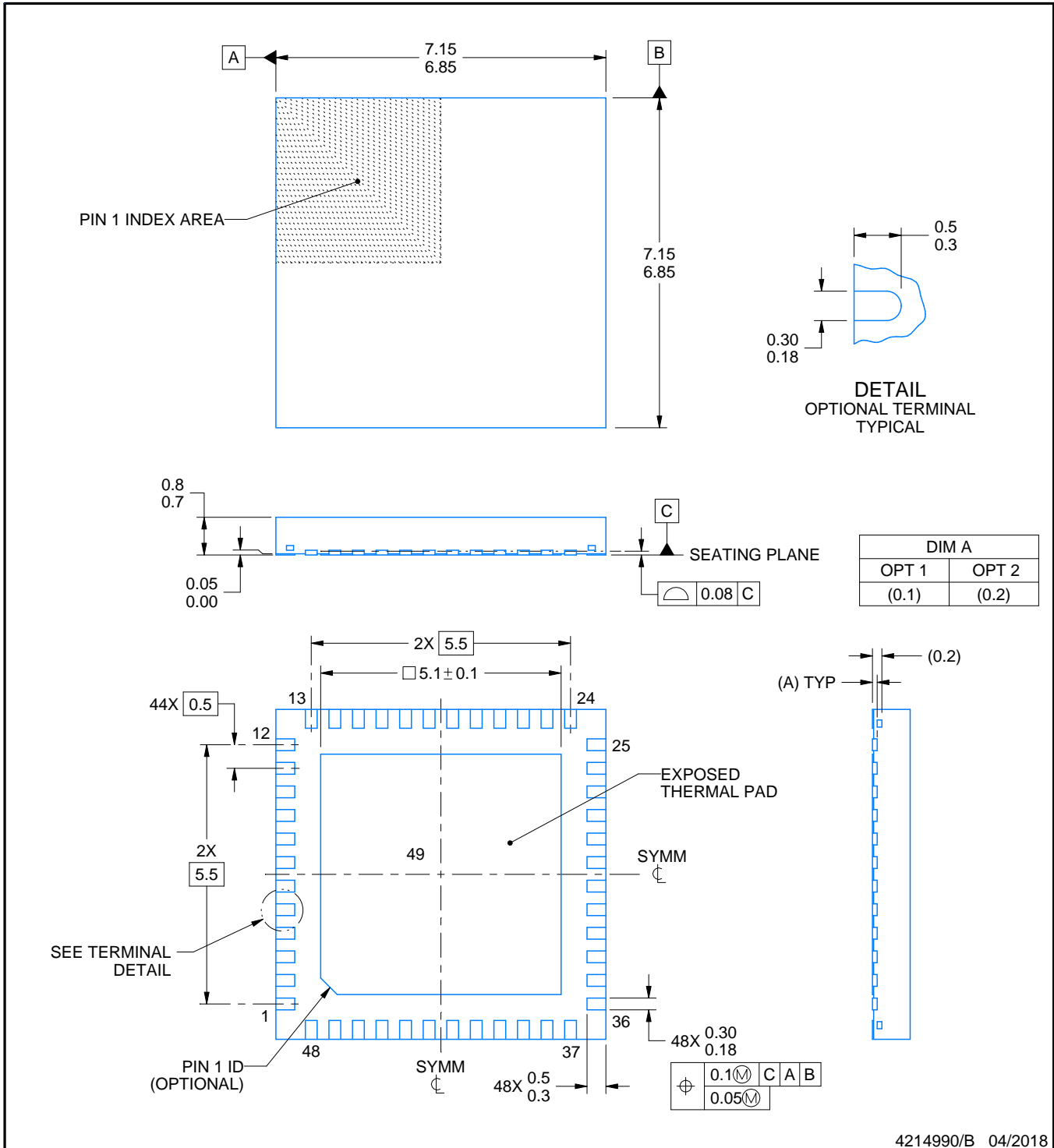
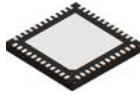
Device	Package Type	Package Drawing	Pins	SPQ	Length (mm)	Width (mm)	Height (mm)
DS90UH925QSQ/NOPB	WQFN	RHS	48	1000	367.0	367.0	38.0
DS90UH925QSQE/NOPB	WQFN	RHS	48	250	210.0	185.0	35.0
DS90UH925QSQX/NOPB	WQFN	RHS	48	2500	367.0	367.0	38.0



4214990/B 04/2018

NOTES:

1. All linear dimensions are in millimeters. Any dimensions in parenthesis are for reference only. Dimensioning and tolerancing per ASME Y14.5M.
2. This drawing is subject to change without notice.
3. The package thermal pad must be soldered to the printed circuit board for thermal and mechanical performance.

# EXAMPLE BOARD LAYOUT

RHS0048A

WQFN - 0.8 mm max height

PLASTIC QUAD FLATPACK - NO LEAD

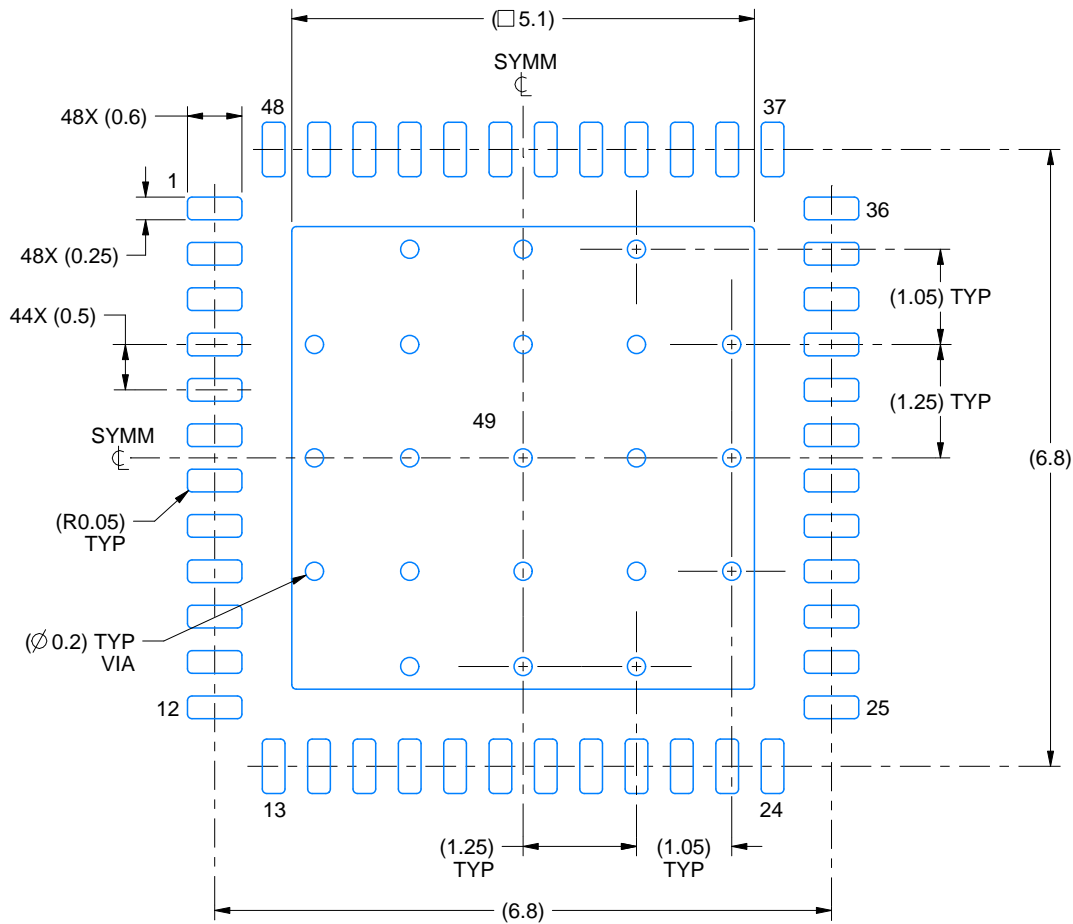

**LAND PATTERN EXAMPLE**  
EXPOSED METAL SHOWN  
SCALE:12X

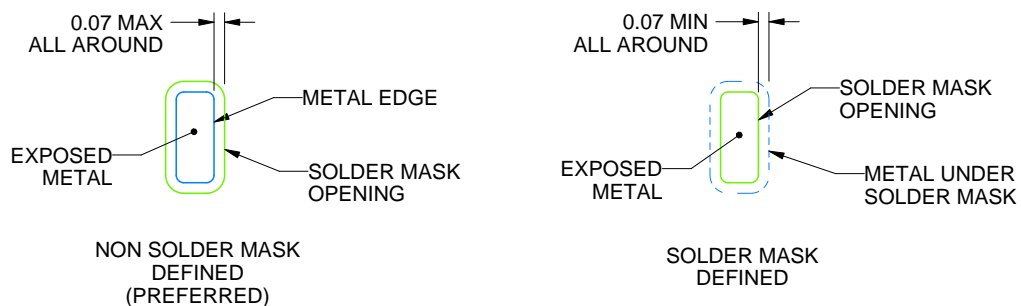

**SOLDER MASK DETAILS**

4214990/B 04/2018

NOTES: (continued)

4. This package is designed to be soldered to a thermal pad on the board. For more information, see Texas Instruments literature number SLUA271 ([www.ti.com/lit/slua271](http://www.ti.com/lit/slua271)).
5. Vias are optional depending on application, refer to device data sheet. If any vias are implemented, refer to their locations shown on this view. It is recommended that vias under paste be filled, plugged or tented.

# EXAMPLE STENCIL DESIGN

RHS0048A

WQFN - 0.8 mm max height

PLASTIC QUAD FLATPACK - NO LEAD

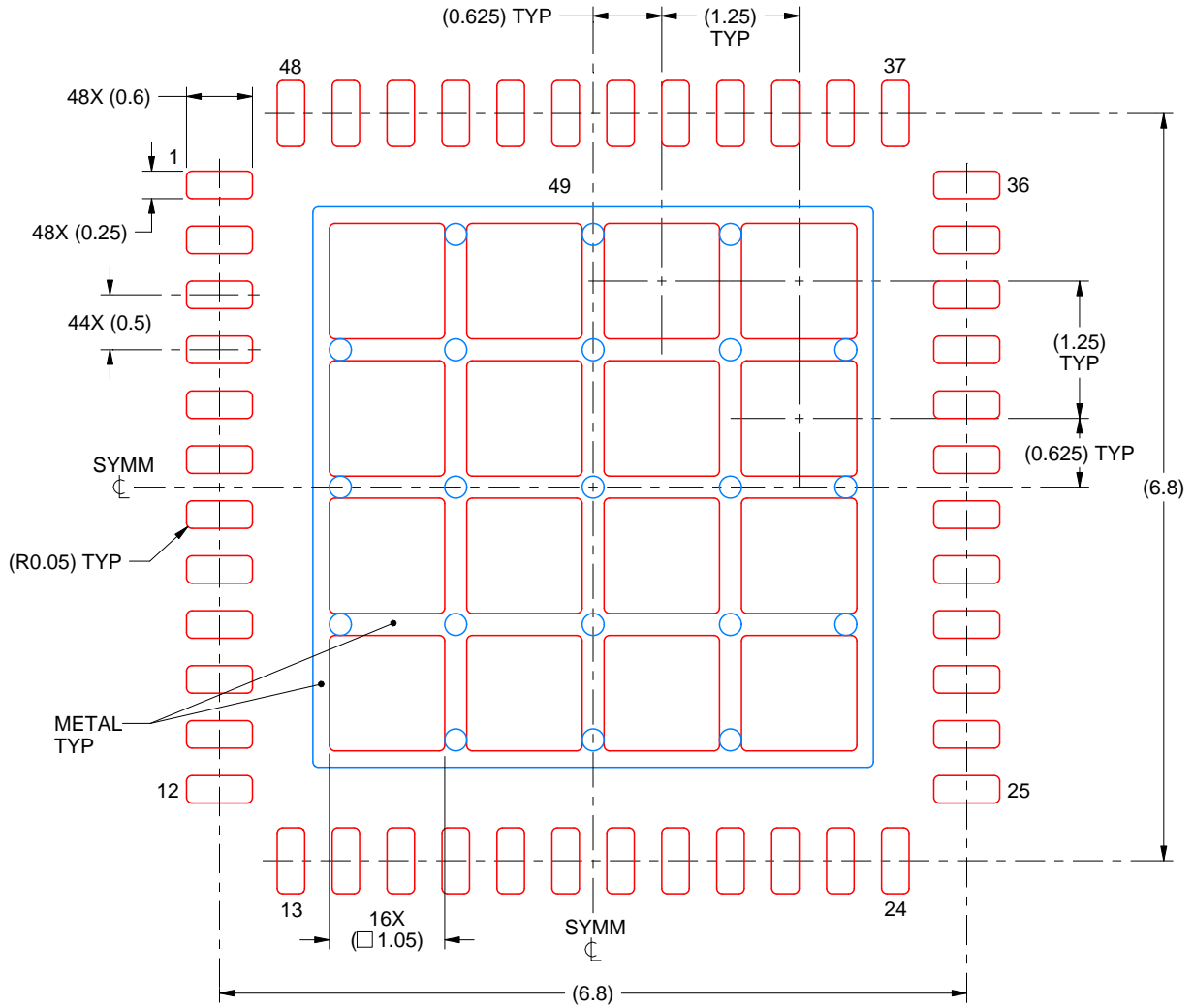

**SOLDER PASTE EXAMPLE**  
 BASED ON 0.125 mm THICK STENCIL

EXPOSED PAD 49  
 68% PRINTED SOLDER COVERAGE BY AREA UNDER PACKAGE  
 SCALE:15X

4214990/B 04/2018

NOTES: (continued)

6. Laser cutting apertures with trapezoidal walls and rounded corners may offer better paste release. IPC-7525 may have alternate design recommendations.

## IMPORTANT NOTICE AND DISCLAIMER

TI PROVIDES TECHNICAL AND RELIABILITY DATA (INCLUDING DATASHEETS), DESIGN RESOURCES (INCLUDING REFERENCE DESIGNS), APPLICATION OR OTHER DESIGN ADVICE, WEB TOOLS, SAFETY INFORMATION, AND OTHER RESOURCES "AS IS" AND WITH ALL FAULTS, AND DISCLAIMS ALL WARRANTIES, EXPRESS AND IMPLIED, INCLUDING WITHOUT LIMITATION ANY IMPLIED WARRANTIES OF MERCHANTABILITY, FITNESS FOR A PARTICULAR PURPOSE OR NON-INFRINGEMENT OF THIRD PARTY INTELLECTUAL PROPERTY RIGHTS.

These resources are intended for skilled developers designing with TI products. You are solely responsible for (1) selecting the appropriate TI products for your application, (2) designing, validating and testing your application, and (3) ensuring your application meets applicable standards, and any other safety, security, or other requirements. These resources are subject to change without notice. TI grants you permission to use these resources only for development of an application that uses the TI products described in the resource. Other reproduction and display of these resources is prohibited. No license is granted to any other TI intellectual property right or to any third party intellectual property right. TI disclaims responsibility for, and you will fully indemnify TI and its representatives against, any claims, damages, costs, losses, and liabilities arising out of your use of these resources.

TI's products are provided subject to TI's Terms of Sale ([www.ti.com/legal/termsofsale.html](http://www.ti.com/legal/termsofsale.html)) or other applicable terms available either on [ti.com](http://ti.com) or provided in conjunction with such TI products. TI's provision of these resources does not expand or otherwise alter TI's applicable warranties or warranty disclaimers for TI products.

Mailing Address: Texas Instruments, Post Office Box 655303, Dallas, Texas 75265  
Copyright © 2019, Texas Instruments Incorporated

## Looking for pricing, stock, or lifecycle information?

Click below to explore more details on WIN SOURCE:

- ⊖ [View DS90UH925QSQE/NOPB on WIN SOURCE](#)
- ⊖ [Texas Instruments Information](#)

## Optimize Your Supply Chain with WIN SOURCE Solutions

- ✓ Global Sourcing Solution
- ✓ Obsolete Management
- ✓ Cost Control Management
- ✓ Shortage Management
- ✓ Alternative Solution
- ✓ Excess Inventory Management