



**THE DATASHEET OF
CY8C20666-24LTXI**



Features

- 1.71V to 5.5V Operating Range
- Low Power CapSense™ Block
 - Configurable Capacitive Sensing Elements
 - Supports Combination of CapSense Buttons, Sliders, Touchpads, Touch Screens, and Proximity Sensor
- Powerful Harvard Architecture Processor
 - M8C Processor Speeds Running to 24 MHz
 - Low Power at High Speed
 - Interrupt Controller
 - Temperature Range: -40°C to +85°C
- Flexible On-Chip Memory
 - Three Program/Data Storage Size Options:
 - CY8C20x36: 8K Flash / 1K SRAM
 - CY8C20x46, CY8C20x96: 16K Flash / 2K SRAM
 - CY8C20x66: 32K Flash / 2K SRAM
 - 50,000 Flash Erase/Write Cycles
 - Partial Flash Updates
 - Flexible Protection Modes
 - In-System Serial Programming (ISSP)
- Full Speed USB
 - Available on CY8C20646, CY8C20666, CY8C20x96 Only
 - 12 Mbps USB 2.0 Compliant
 - Eight Unidirectional Endpoints
 - One Bidirectional Control Endpoint
 - Dedicated 512 Byte Buffer
 - Internally Regulated at 3.3V
- Precision, Programmable Clocking
 - Internal Main Oscillator: 6/12/24 MHz ± 5%
 - Internal Low Speed Oscillator at 32 kHz for Watchdog and Sleep Timers
 - Precision 32 kHz Oscillator for Optional External Crystal
 - 0.25% Accuracy for USB with No External Components (CY8C20646, CY8C20666, CY8C20x96 only)
- Programmable Pin Configurations
 - Up to 36 GPIO (Depending on Package)
 - Dual Mode GPIO: All GPIO Support Digital I/O and Analog Input
 - 25 mA Sink Current on All GPIO
 - Pull up, High Z, Open Drain Modes on All GPIO
 - CMOS Drive Mode (5 mA Source Current) on Ports 0 and 1:
 - 20 mA (at 3.0V) Total Source Current on Port 0
 - 20 mA (at 3.0V) Total Source Current on Port 1
 - Selectable, Regulated Digital I/O on Port 1
 - Configurable Input Threshold on Port 1
 - Hot Swap Capability on all Port 1 GPIO
- Versatile Analog Mux
 - Common Internal Analog Bus
 - Simultaneous Connection of I/O
 - High PSRR Comparator
 - Low Dropout Voltage Regulator for All Analog Resources
- Additional System Resources
 - I2C Slave:
 - Selectable to 50 kHz, 100 kHz, or 400 kHz
 - No Clock Stretching Required (under most conditions)
 - Implementation During Sleep Modes with Less Than 100 µA
 - Hardware Address Validation
 - SPI™ Master and Slave: Configurable 46.9 kHz to 12 MHz
 - Three 16-Bit Timers
 - Watchdog and Sleep Timers
 - Internal Voltage Reference
 - Integrated Supervisory Circuit
 - 8-bit Delta-Sigma Analog-to-Digital Converter
 - Two General Purpose High Speed, Low Power Analog Comparators
- Complete Development Tools
 - Free Development Tool (PSoC Designer™)
 - Full Featured, In-Circuit Emulator and Programmer
 - Full Speed Emulation
 - Complex Breakpoint Structure
 - 128K Trace Memory
- Package Options
 - CY8C20x36:
 - 16-Pin 3 x 3 x 0.6 mm QFN
 - 24-Pin 4 x 4 x 0.6 mm QFN
 - 32-Pin 5 x 5 x 0.6 mm QFN
 - 48-Pin SSOP
 - 48-Pin 7 x 7 x 1.0 mm QFN
 - CY8C20x46:
 - 16-Pin 3 x 3 x 0.6 mm QFN
 - 24-Pin 4 x 4 x 0.6 mm QFN
 - 32-Pin 5 x 5 x 0.6 mm QFN
 - 48-Pin SSOP
 - 48-Pin 7 x 7 x 1.0 mm QFN (with USB)
 - CY8C20x96:
 - 24-Pin 4 x 4 x 0.6 mm QFN (with USB)
 - 32-Pin 5 x 5 x 0.6 mm QFN (with USB)
 - CY8C20x66:
 - 32-Pin 5 x 5 x 0.6 mm QFN
 - 48-Pin 7 x 7 x 1.0 mm QFN (with USB)
 - 48-Pin SSOP

Logic Block Diagram

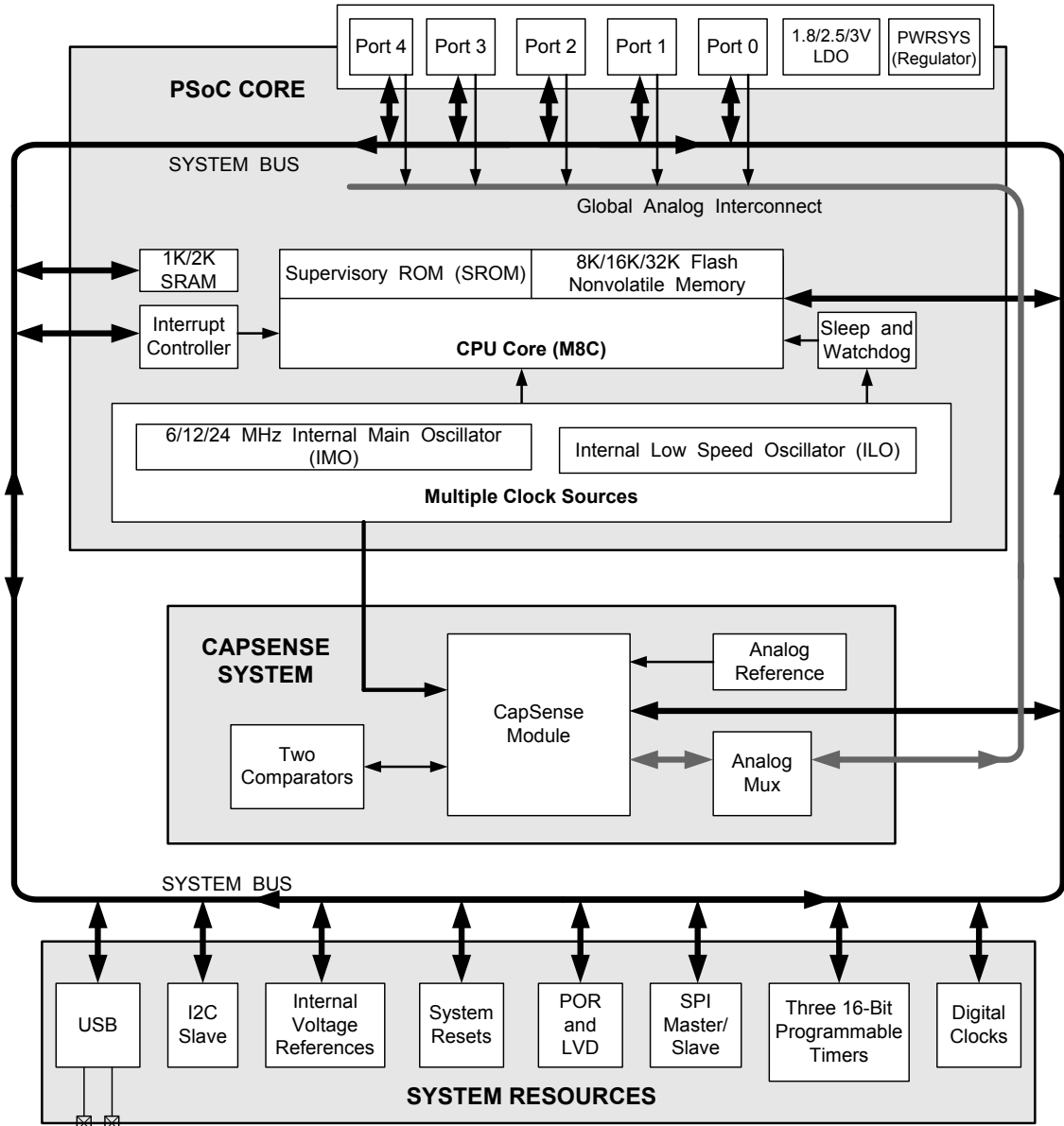

PSoC[®] Functional Overview

The PSoC family consists of on-chip Controller devices. These devices are designed to replace multiple traditional MCU-based components with one, low cost single-chip programmable component. A PSoC device includes configurable analog and digital blocks, and programmable interconnect. This architecture allows the user to create customized peripheral configurations, to match the requirements of each individual application. Additionally, a fast CPU, Flash program memory, SRAM data memory, and configurable I/O are included in a range of convenient pinouts.

The architecture for this device family, as shown in the [Logic Block Diagram on page 2](#), is comprised of three main areas: the Core, the CapSense Analog System, and the System Resources (including a full speed USB port). A common, versatile bus allows connection between I/O and the analog system. Each CY8C20x36/46/66/96 PSoC Device includes a dedicated CapSense block that provides sensing and scanning control circuitry for capacitive sensing applications. Depending on the PSoC package, up to 36 general purpose IO (GPIO) are also included. The GPIO provides access to the MCU and analog mux.

PSoC Core

The PSoC Core is a powerful engine that supports a rich instruction set. It encompasses SRAM for data storage, an interrupt controller, sleep and watchdog timers, and IMO (internal main oscillator) and ILO (internal low speed oscillator). The CPU core, called the M8C, is a powerful processor with speeds up to 24 MHz. The M8C is a 4-MIPS, 8-bit Harvard architecture microprocessor.

System Resources provide additional capability, such as configurable USB and I2C slave/SPI master-slave communication interface, three 16-bit programmable timers, and various system resets supported by the M8C.

The Analog System is composed of the CapSense PSoC block and an internal 1.2V analog reference, which together support capacitive sensing of up to 36 inputs.

CapSense Analog System

The Analog System contains the capacitive sensing hardware. Several hardware algorithms are supported. This hardware performs capacitive sensing and scanning without requiring external components. Capacitive sensing is configurable on each GPIO pin. Scanning of enabled CapSense pins are completed quickly and easily across multiple ports.

Figure 1. Analog System Block Diagram

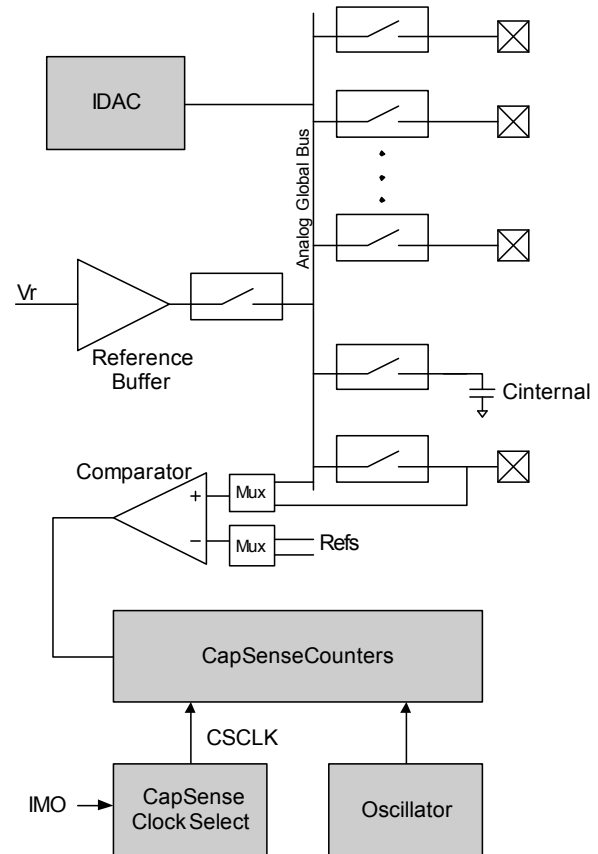

Analog Multiplexer System

The Analog Mux Bus can connect to every GPIO pin. Pins are connected to the bus individually or in any combination. The bus also connects to the analog system for analysis with the CapSense block comparator.

Switch control logic enables selected pins to precharge continuously under hardware control. This enables capacitive measurement for applications such as touch sensing. Other multiplexer applications include:

- Complex capacitive sensing interfaces, such as sliders and touchpads.
- Chip-wide mux that allows analog input from any I/O pin.
- Crosspoint connection between any I/O pin combinations.

When designing capacitive sensing applications, refer to the latest signal-to-noise signal level requirements Application Notes, which can be found under <http://www.cypress.com> > Documentation > Application Notes. In general, and unless otherwise noted in the relevant Application Notes, the minimum signal-to-noise ratio (SNR) for CapSense applications is 5:1.

Additional System Resources

System Resources, some of which are listed in the previous sections, provide additional capability useful to complete systems. Additional resources include low voltage detection and power on reset. The merits of each system resource are listed here:

- The I2C slave/SPI master-slave module provides 50/100/400 kHz communication over two wires. SPI communication over three or four wires runs at speeds of 46.9 kHz to 3 MHz (lower for a slower system clock).
- The I2C hardware address recognition feature reduces the already low power consumption by eliminating the need for CPU intervention until a packet addressed to the target device is received.
- Low Voltage Detection (LVD) interrupts can signal the application of falling voltage levels, while the advanced POR (Power-On-Reset) circuit eliminates the need for a system supervisor.
- An internal reference provides an absolute reference for capacitive sensing.
- A register-controlled bypass mode allows the user to disable the LDO.
- Standard Cypress PSoC IDE tools are available for debugging the CY8C20x36/46/66/96 family of parts. However, the additional trace length and a minimal ground plane in the Flex-Pod can create noise problems that make it difficult to debug the design. A custom bonded On-Chip Debug (OCD) device is available in an 48-pin QFN package. The OCD device is recommended for debugging designs that have high current and/or high analog accuracy requirements. The QFN package is compact and is connected to the ICE through a high density connector.

Getting Started

The quickest way to understand PSoC silicon is to read this data sheet and then use the PSoC Designer Integrated Development Environment (IDE). This data sheet is an overview of the PSoC integrated circuit and presents specific pin, register, and electrical specifications.

For in depth information, along with detailed programming details, see the PSoC[®] Programmable System-on-Chip[™] Technical Reference Manual for CY8C20x36/46/66/96 PSoC Devices.

For up-to-date ordering, packaging, and electrical specification information, see the latest PSoC device data sheets on the web at www.cypress.com/psoc.

Application Notes

Application notes are an excellent introduction to the wide variety of possible PSoC designs. They are located here: www.cypress.com/psoc. Select Application Notes under the Documentation tab.

Development Kits

PSoC Development Kits are available online from Cypress at www.cypress.com/shop and through a growing number of regional and global distributors, which include Arrow, Avnet, Digi-Key, Farnell, Future Electronics, and Newark.

Training

Free PSoC technical training (on demand, webinars, and workshops) is available online at www.cypress.com/training. The training covers a wide variety of topics and skill levels to assist you in your designs.

CYPros Consultants

Certified PSoC Consultants offer everything from technical assistance to completed PSoC designs. To contact or become a PSoC Consultant go to www.cypress.com/cypros.

Solutions Library

Visit our growing library of solution focused designs at www.cypress.com/solutions. Here you can find various application designs that include firmware and hardware design files that enable you to complete your designs quickly.

Technical Support

For assistance with technical issues, search KnowledgeBase articles and forums at www.cypress.com/support. If you cannot find an answer to your question, call technical support at 1-800-541-4736.

Development Tools

PSoC Designer is a Microsoft® Windows-based, integrated development environment for the Programmable System-on-Chip (PSoC) devices. The PSoC Designer IDE and application runs on Windows XP and Windows Vista.

This system provides design database management by project, an integrated debugger with In-Circuit Emulator, in-system programming support, and built-in support for third-party assemblers and C compilers.

PSoC Designer also supports C language compilers developed specifically for the devices in the PSoC family.

PSoC Designer Software Subsystems

System-Level View

The system-level view is a drag-and-drop visual embedded system design environment based on PSoC Express. In this view you solve design problems the same way you might think about the system. Select input and output devices based upon system requirements. Add a communication interface and define the interface to the system (registers). Define when and how an output device changes state based upon any/all other system devices. Based upon the design, PSoC Designer automatically selects one or more PSoC devices that match your system requirements.

PSoC Designer generates all embedded code, then compiles and links it into a programming file for a specific PSoC device.

Chip-Level View

The chip-level view is a more traditional integrated development environment (IDE) based on PSoC Designer 4.x. You choose a base device to work with and then select different onboard analog and digital components called user modules that use the PSoC blocks. Examples of user modules are ADCs, DACs, Amplifiers, and Filters. You configure the user modules for your chosen application and connect them to each other and to the proper pins. Then you generate your project. This prepopulates your project with APIs and libraries that you can use to program your application.

The tool also supports easy development of multiple configurations and dynamic reconfiguration. Dynamic reconfiguration allows for changing configurations at run time.

Hybrid Designs

You can begin in the system-level view, allow it to choose and configure your user modules, routing, and generate code, then switch to the chip-level view to gain complete control over on-chip resources. All views of the project share common code editor, builder, and common debug, emulation, and programming tools.

Code Generation Tools

PSoC Designer supports multiple third-party C compilers and assemblers. The code generation tools work seamlessly within the PSoC Designer interface and have been tested with a full range of debugging tools. The choice is yours.

Assemblers. The assemblers allow assembly code to be merged seamlessly with C code. Link libraries automatically use absolute addressing or are compiled in relative mode, and linked with other software modules to get absolute addressing.

C Language Compilers. C language compilers are available that support the PSoC family of devices. The products allow you to create complete C programs for the PSoC family devices.

The optimizing C compilers provide all the features of C tailored to the PSoC architecture. They come complete with embedded libraries providing port and bus operations, standard keypad and display support, and extended math functionality.

Debugger

PSoC Designer has a debug environment that provides hardware in-circuit emulation, allowing you to test the program in a physical system while providing an internal view of the PSoC device. Debugger commands allow the designer to read and program and read and write data memory, read and write I/O registers, read and write CPU registers, set and clear breakpoints, and provide program run, halt, and step control. The debugger also allows the designer to create a trace buffer of registers and memory locations of interest.

Online Help System

The online help system displays online, context-sensitive help for the user. Designed for procedural and quick reference, each functional subsystem has its own context-sensitive help. This system also provides tutorials and links to FAQs and an Online Support Forum to aid the designer in getting started.

In-Circuit Emulator

A low cost, high functionality In-Circuit Emulator (ICE) is available for development support. This hardware has the capability to program single devices.

The emulator consists of a base unit that connects to the PC by way of a USB port. The base unit is universal and operates with all PSoC devices. Emulation pods for each device family are available separately. The emulation pod takes the place of the PSoC device in the target board and performs full speed (24 MHz) operation.

Designing with PSoC Designer

The development process for the PSoC device differs from that of a traditional fixed function microprocessor. The configurable analog and digital hardware blocks give the PSoC architecture a unique flexibility that pays dividends in managing specification change during development and by lowering inventory costs. These configurable resources, called PSoC Blocks, have the ability to implement a wide variety of user-selectable functions.

The PSoC development process can be summarized in the following four steps:

1. Select Components
2. Configure Components
3. Organize and Connect
4. Generate, Verify, and Debug

Select Components

Both the system-level and chip-level views provide a library of pre-built, pre-tested hardware peripheral components. In the system-level view these components are called “drivers” and correspond to inputs (a thermistor, for example), outputs (a brushless DC fan, for example), communication interfaces (I²C-bus, for example), and the logic to control how they interact with one another (called valuator).

In the chip-level view the components are called “user modules.” User modules make selecting and implementing peripheral devices simple, and come in analog, digital, and programmable system-on-chip varieties.

Configure Components

Each of the components you select establishes the basic register settings that implement the selected function. They also provide parameters and properties that allow you to tailor their precise configuration to your particular application. For example, a Pulse Width Modulator (PWM) User Module configures one or more digital PSoC blocks, one for each 8 bits of resolution. The user module parameters permit you to establish the pulse width and duty cycle. Configure the parameters and properties to correspond to your chosen application. Enter values directly or by selecting values from drop-down menus.

Both the system-level drivers and chip-level user modules are documented in data sheets that are viewed directly in PSoC Designer. These data sheets explain the internal operation of the component and provide performance specifications. Each data sheet describes the use of each user module parameter or driver property, and other information you may need to successfully implement your design.

Organize and Connect

You build signal chains at the chip level by interconnecting user modules to each other and the I/O pins, or connect system-level inputs, outputs, and communication interfaces to each other with valuator functions.

In the system-level view selecting a potentiometer driver to control a variable speed fan driver and setting up the valuator to control the fan speed based on input from the pot selects, places, routes, and configures a programmable gain amplifier (PGA) to buffer the input from the potentiometer, an analog-to-digital converter (ADC) to convert the potentiometer’s output to a digital signal, and a PWM to control the fan.

In the chip-level view, you perform the selection, configuration, and routing so that you have complete control over the use of all on-chip resources.

Generate, Verify, and Debug

When you are ready to test the hardware configuration or move on to developing code for the project, you perform the “Generate Configuration Files” step. This causes PSoC Designer to generate source code that automatically configures the device to your specification and provides the software for the system.

Both system-level and chip-level designs generate software based on your design. The chip-level design provides application programming interfaces (APIs) with high-level functions to control and respond to hardware events at run time and interrupt service routines that you can adapt as needed. The system-level design also generates a C main() program that completely controls the chosen application and contains placeholders for custom code at strategic positions allowing you to further refine the software without disrupting the generated code.

A complete code development environment allows you to develop and customize your applications in C, assembly language, or both.

The last step in the development process takes place inside PSoC Designer’s Debugger (access by clicking the Connect icon). PSoC Designer downloads the HEX image to the ICE where it runs at full speed. PSoC Designer debugging capabilities rival those of systems costing many times more. In addition to traditional single-step, run-to-breakpoint and watch-variable features, the debug interface provides a large trace buffer and allows you to define complex breakpoint events that include monitoring address and data bus values, memory locations and external signals.

Document Conventions

Acronyms Used

The following table lists the acronyms that are used in this document.

Table 1. Acronyms

Acronym	Description
AC	alternating current
API	application programming interface
CPU	central processing unit
DC	direct current
FSR	full scale range
GPIO	general purpose I/O
GUI	graphical user interface
ICE	in-circuit emulator
ILO	internal low speed oscillator
IMO	internal main oscillator
I/O	input/output
LSb	least-significant bit
LVD	low voltage detect
MSb	most-significant bit
POR	power on reset
PPOR	precision power on reset
PSoC®	Programmable System-on-Chip™
SLIMO	slow IMO
SRAM	static random access memory

Units of Measure

A units of measure table is located in the Electrical Specifications section. [Table 11 on page 17](#) lists all the abbreviations used to measure the PSoC devices.

Numeric Naming

Hexadecimal numbers are represented with all letters in uppercase with an appended lowercase 'h' (for example, '14h' or '3Ah'). Hexadecimal numbers may also be represented by a '0x' prefix, the C coding convention. Binary numbers have an appended lowercase 'b' (for example, '01010100b' or '01000011b'). Numbers not indicated by an 'h', 'b', or 0x are decimal.

Pinouts

The CY8C20x36/46/66/96 PSoC device is available in a variety of packages which are listed and illustrated in the following tables. Every port pin (labeled with a "P") is capable of Digital I/O and connection to the common analog bus. However, Vss, Vdd, and XRES are not capable of Digital I/O.

16-Pin QFN (No E-Pad)

Table 2. Pin Definitions - CY8C20236, CY8C20246 PSoC Device ^[2]

Pin No.	Type		Name	Description
	Digital	Analog		
1	I/O	I	P2[5]	Crystal output (XOut)
2	I/O	I	P2[3]	Crystal input (XIn)
3	IOHR	I	P1[7]	I2C SCL, SPI SS
4	IOHR	I	P1[5]	I2C SDA, SPI MISO
5	IOHR	I	P1[3]	SPI CLK
6	IOHR	I	P1[1]	ISSP CLK ^[1] , I2C SCL, SPI MOSI
7	Power		Vss	Ground connection
8	IOHR	I	P1[0]	ISSP DATA ^[1] , I2C SDA, SPI CLK
9	IOHR	I	P1[2]	
10	IOHR	I	P1[4]	Optional external clock (EXTCLK)
11	Input		XRES	Active high external reset with internal pull down
12	IOH	I	P0[4]	
13	Power		Vdd	Supply voltage
14	IOH	I	P0[7]	
15	IOH	I	P0[3]	Integrating input
16	IOH	I	P0[1]	Integrating input

Figure 2. CY8C20236, CY8C20246 PSoC Device

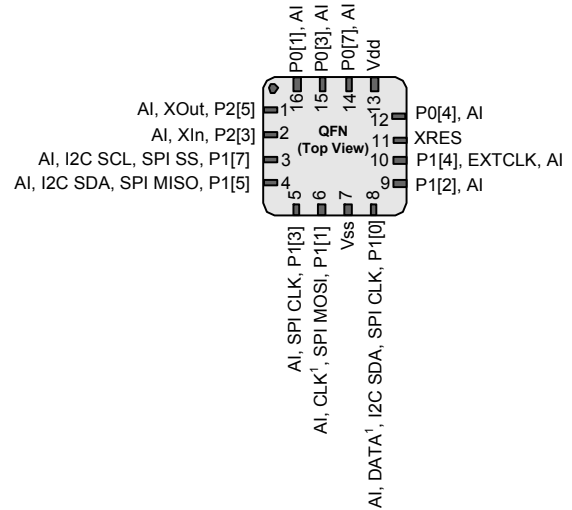

LEGEND A = Analog, I = Input, O = Output, OH = 5 mA High Output Drive, R = Regulated Output.

Notes

- These are the ISSP pins, which are not High Z at POR (Power On Reset).
- During power up or reset event, device P1[1] and P1[0] may disturb the I2C bus. Use alternate pins if you encounter any issues.

24-Pin QFN

Table 3. Pin Definitions - CY8C20336, CY8C20346 [2, 3]

Pin No.	Type		Name	Description
	Digital	Analog		
1	I/O	I	P2[5]	Crystal output (XOut)
2	I/O	I	P2[3]	Crystal input (XIn)
3	I/O	I	P2[1]	
4	IOHR	I	P1[7]	I2C SCL, SPI SS
5	IOHR	I	P1[5]	I2C SDA, SPI MISO
6	IOHR	I	P1[3]	SPI CLK
7	IOHR	I	P1[1]	ISSP CLK ^[1] , I2C SCL, SPI MOSI
8			NC	No connection
9	Power		Vss	Ground connection
10	IOHR	I	P1[0]	ISSP DATA ^[1] , I2C SDA, SPI CLK
11	IOHR	I	P1[2]	
12	IOHR	I	P1[4]	Optional external clock input (EXTCLK)
13	IOHR	I	P1[6]	
14	Input		XRES	Active high external reset with internal pull down
15	I/O	I	P2[0]	
16	IOH	I	P0[0]	
17	IOH	I	P0[2]	
18	IOH	I	P0[4]	
19	IOH	I	P0[6]	
20	Power		Vdd	Supply voltage
21	IOH	I	P0[7]	
22	IOH	I	P0[5]	
23	IOH	I	P0[3]	Integrating input
24	IOH	I	P0[1]	Integrating input
CP	Power		Vss	Center pad must be connected to ground

Figure 3. CY8C20336, CY8C20346 PSOC Device

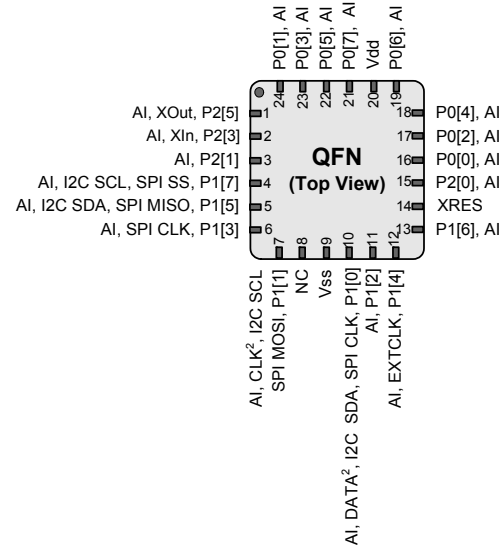

LEGEND A = Analog, I = Input, O = Output, OH = 5 mA High Output Drive, R = Regulated Output.

Note

3. The center pad (CP) on the QFN package must be connected to ground (Vss) for best mechanical, thermal, and electrical performance. If not connected to ground, it must be electrically floated and not connected to any other signal.

24-Pin QFN with USB

Table 4. Pin Definitions - CY8C20396 PSoC Device [2, 3]

Pin No.	Type		Name	Description
	Digital	Analog		
1	I/O	I	P2[5]	
2	I/O	I	P2[3]	
3	I/O	I	P2[1]	
4	IOHR	I	P1[7]	I2C SCL, SPI SS
5	IOHR	I	P1[5]	I2C SDA, SPI MISO
6	IOHR	I	P1[3]	SPI CLK
7	IOHR	I	P1[1]	ISSP CLK, I2C SCL, SPI MOSI
8	Power		VSS	Ground
9	I/O	I	D+	USB D+
10	I/O	I	D-	USB D-
11	Power		VDD	Supply
12	IOHR	I	P1[0]	ISSP DATA, I2C SDA
13	IOHR	I	P1[2]	
14	IOHR	I	P1[4]	Optional external clock input (EXTCLK)
15	IOHR	I	P1[6]	
16	RESET INPUT		XRES	Active high external reset with internal pull down
17	IOH	I	P0[0]	
18	IOH	I	P0[2]	
19	IOH	I	P0[4]	
20	IOH	I	P0[6]	
21	IOH	I	P0[7]	
22	IOH	I	P0[5]	
23	IOH	I	P0[3]	Integrating input
24	IOH	I	P0[1]	Integrating input
CP	Power		VSS	Thermal pad must be connected to Ground

LEGEND I = Input, O = Output, OH = 5 mA High Output Drive, R = Regulated Output

Figure 4. CY8C20396 PSoC Device

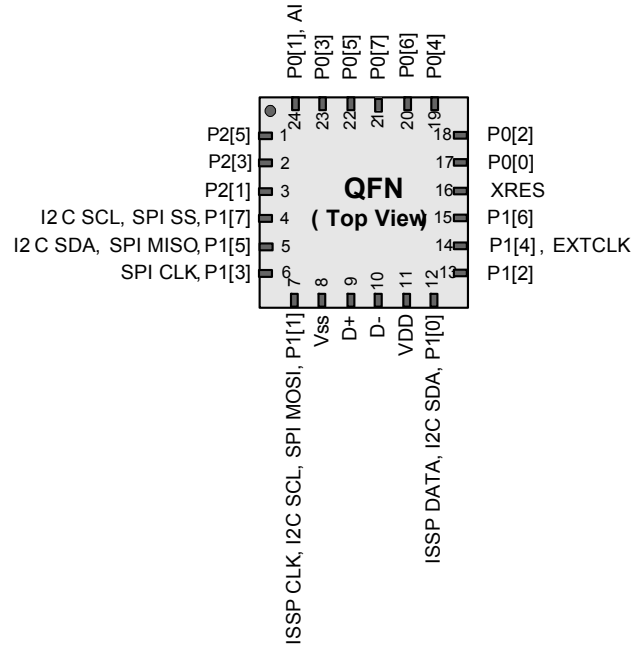

32-Pin QFN (with USB)

Table 6. Pin Definitions - CY8C20496 PSoC Device [2, 3]

Pin No.	Type		Name	Description
	Digital	Analog		
1	IOH	I	P0[1]	
2	I/O	I	P2[5]	XTAL Out
3	I/O	I	P2[3]	XTAL In
4	I/O	I	P2[1]	
5	IOHR	I	P1[7]	I2C SCL, SPI SS
6	IOHR	I	P1[5]	I2C SDA, SPI MISO
7	IOHR	I	P1[3]	SPI CLK
8	IOHR	I	P1[1]	TC CLK, I2C SCL, SPI MOSI
9	Power		V _{SS}	Ground Pin
10	I	I	D+	USB PHY
11			D-	USB PHY
12	Power		V _{DD}	Power pin
13	IOHR	I	P1[0]	TC DATA*, I2C SDA, SPI CLKI
14	IOHR	I	P1[2]	
15	IOHR	I	P1[4]	EXTCLK
16	IOHR	I	P1[6]	
17	Input		XRES	Active high external reset with internal pull down
18	I/O	I	P3[0]	
19	I/O	I	P3[2]	
20	I/O	I	P2[0]	
21	I/O	I	P2[2]	
22	I/O	I	P2[4]	
23	I/O	I	P2[6]	
24	IOH	I	P0[0]	
25	IOH	I	P0[2]	
26	IOH	I	P0[4]	
27	IOH	I	P0[6]	
28	Power		V _{DD}	Power Pin
29	IOH	I	P0[7]	
30	IOH	I	P0[5]	
31	IOH	I	P0[3]	
32	Power		V _{SS}	Ground Pin

Figure 5. CY8C20496 PSoC Device

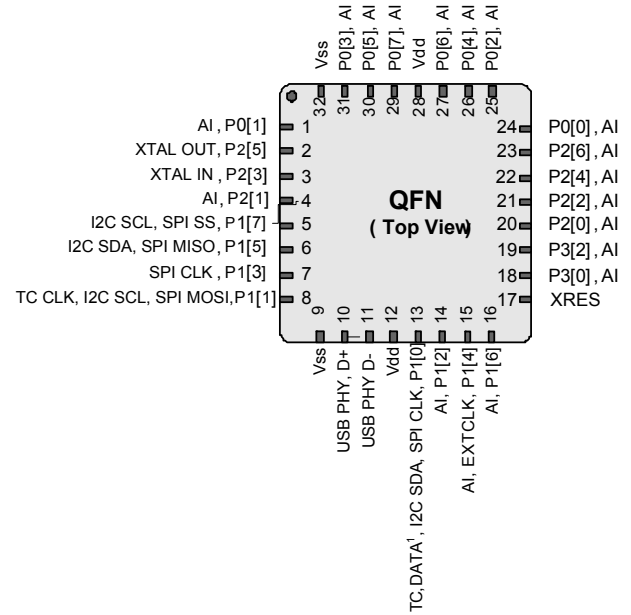

LEGEND A = Analog, I = Input, O = Output, OH = 5 mA High Output Drive, R = Regulated Output.

48-Pin SSOP

Table 7. Pin Definitions - CY8C20536, CY8C20546, and CY8C20566 PSoC Device^[2]

Pin No.	Digital	Analog	Name	Description
1	IOH	I	P0[7]	
2	IOH	I	P0[5]	
3	IOH	I	P0[3]	
4	IOH	I	P0[1]	
5	I/O	I	P2[7]	
6	I/O	I	P2[5]	XTAL Out
7	I/O	I	P2[3]	XTAL In
8	I/O	I	P2[1]	
9			NC	No connection
10			NC	No connection
11	I/O	I	P4[3]	
12	I/O	I	P4[1]	
13			NC	No connection
14	I/O	I	P3[7]	
15	I/O	I	P3[5]	
16	I/O	I	P3[3]	
17	I/O	I	P3[1]	
18			NC	No connection
19			NC	No connection
20	IOHR	I	P1[7]	I2C SCL, SPI SS
21	IOHR	I	P1[5]	I2C SDA, SPI MISO
22	IOHR	I	P1[3]	SPI CLK
23	IOHR	I	P1[1]	TC CLK ^[1] , I2C SCL, SPI MOSI
24			VSS	Ground Pin
25	IOHR	I	P1[0]	TC DATA ^[1] , I2C SDA, SPI CLK
26	IOHR	I	P1[2]	
27	IOHR	I	P1[4]	EXT CLK
28	IOHR	I	P1[6]	
29			NC	No connection
30			NC	No connection
31			NC	No connection
32			NC	No connection
				Pin No.
				Digital
				Analog
				Name
				Description
33			NC	No connection
34			NC	No connection
35			XRES	Active high external reset with internal pull down
36	I/O	I	P3[0]	
37	I/O	I	P3[2]	
38	I/O	I	P3[4]	
39	I/O	I	P3[6]	
40	I/O	I	P2[0]	
41	I/O	I	P2[2]	
42	I/O	I	P2[4]	
43	I/O	I	P2[6]	
44	IOH	I	P0[0]	
45	IOH	I	P0[2]	
46	IOH	I	P0[4]	
47	IOH	I	P0[6]	
48	Power		Vdd	Power Pin

Figure 6. CY8C20536, CY8C20546, and CY8C20566 PSoC Device

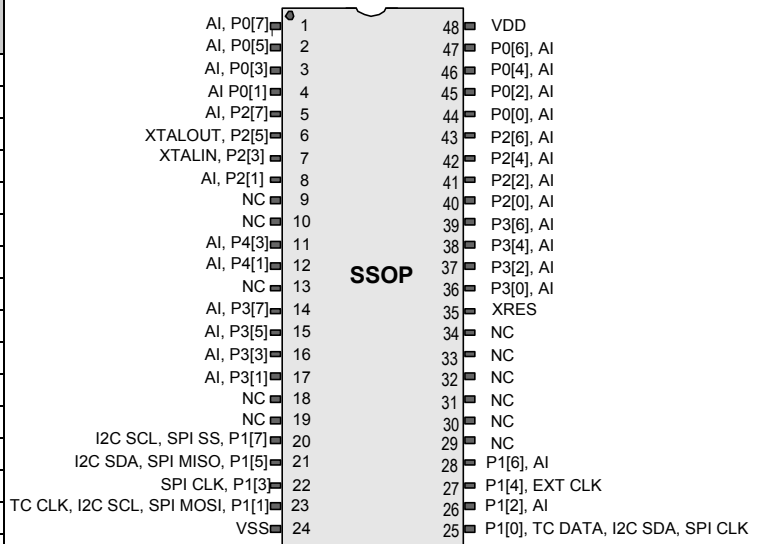

LEGEND A = Analog, I = Input, O = Output, NC = No Connection, H = 5 mA High Output Drive, R = Regulated Output Option.

48-Pin QFN

Table 8. Pin Definitions - CY8C20636 PSoC Device [2, 3]

Pin No.	Digital	Analog	Name	Description
1			NC	No connection
2	I/O	I	P2[7]	
3	I/O	I	P2[5]	Crystal output (XOut)
4	I/O	I	P2[3]	Crystal input (XIn)
5	I/O	I	P2[1]	
6	I/O	I	P4[3]	
7	I/O	I	P4[1]	
8	I/O	I	P3[7]	
9	I/O	I	P3[5]	
10	I/O	I	P3[3]	
11	I/O	I	P3[1]	
12	IOHR	I	P1[7]	I2C SCL, SPI SS
13	IOHR	I	P1[5]	I2C SDA, SPI MISO
14			NC	No connection
15			NC	No connection
16	IOHR	I	P1[3]	SPI CLK
17	IOHR	I	P1[1]	ISSP CLK ^[1] , I2C SCL, SPI MOSI
18	Power		Vss	Ground connection
19			DNU	
20			DNU	
21	Power		Vdd	Supply voltage
22	IOHR	I	P1[0]	ISSP DATA ^[1] , I2C SDA, SPI CLK
23	IOHR	I	P1[2]	
24	IOHR	I	P1[4]	Optional external clock input (EXTCLK)
25	IOHR	I	P1[6]	
26	Input		XRES	Active high external reset with internal pull down
27	I/O	I	P3[0]	
28	I/O	I	P3[2]	
29	I/O	I	P3[4]	
30	I/O	I	P3[6]	
31	I/O	I	P4[0]	
32	I/O	I	P4[2]	
33	I/O	I	P2[0]	
34	I/O	I	P2[2]	
35	I/O	I	P2[4]	
36	I/O	I	P2[6]	
37	IOH	I	P0[0]	
38	IOH	I	P0[2]	
39	IOH	I	P0[4]	
40	IOH	I	P0[6]	
41	Power		Vdd	Supply voltage
42			NC	No connection
43			NC	No connection
44	IOH	I	P0[7]	
45	IOH	I	P0[5]	
46	IOH	I	P0[3]	Integrating input
47	Power		Vss	Ground connection
48	IOH	I	P0[1]	
CP	Power		Vss	Center pad must be connected to ground

Figure 7. CY8C20636 PSoC Device

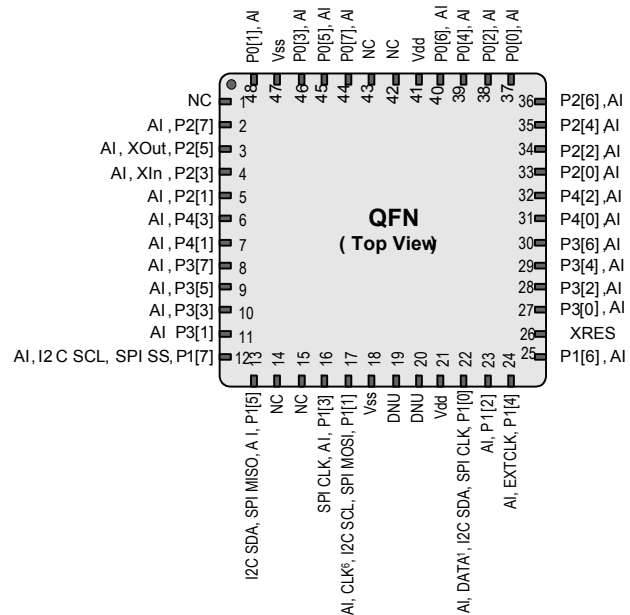

LEGEND A = Analog, I = Input, O = Output, NC = No Connection H = 5 mA High Output Drive, R = Regulated Output.

48-Pin QFN with USB

Table 9. Pin Definitions - CY8C20646, CY8C20666 PSoC Device [2, 3]

Pin No.	Digital	Analog	Name	Description
1			NC	No connection
2	I/O	I	P2[7]	
3	I/O	I	P2[5]	Crystal output (XOut)
4	I/O	I	P2[3]	Crystal input (XIn)
5	I/O	I	P2[1]	
6	I/O	I	P4[3]	
7	I/O	I	P4[1]	
8	I/O	I	P3[7]	
9	I/O	I	P3[5]	
10	I/O	I	P3[3]	
11	I/O	I	P3[1]	
12	IOHR	I	P1[7]	I2C SCL, SPI SS
13	IOHR	I	P1[5]	I2C SDA, SPI MISO
14			NC	No connection
15			NC	No connection
16	IOHR	I	P1[3]	SPI CLK
17	IOHR	I	P1[1]	ISSP CLK ^[1] , I2C SCL, SPI MOSI
18	Power		Vss	Ground connection
19	I/O		D+	USB D+
20	I/O		D-	USB D-
21	Power		Vdd	Supply voltage
22	IOHR	I	P1[0]	ISSP DATA ^[1] , I2C SDA, SPI CLK
23	IOHR	I	P1[2]	
24	IOHR	I	P1[4]	Optional external clock input (EXTCLK)
25	IOHR	I	P1[6]	
26	Input		XRES	Active high external reset with internal pull down
27	I/O	I	P3[0]	
28	I/O	I	P3[2]	
29	I/O	I	P3[4]	

Figure 8. CY8C20646, CY8C20666 PSoC Device

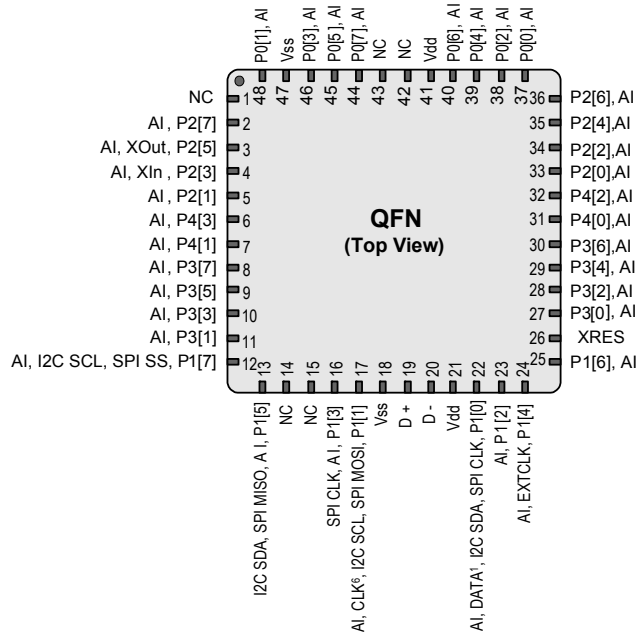

Pin No.	Digital	Analog	Name	Description
30	I/O	I	P3[6]	
31	I/O	I	P4[0]	
32	I/O	I	P4[2]	
33	I/O	I	P2[0]	
34	I/O	I	P2[2]	
35	I/O	I	P2[4]	
36	I/O	I	P2[6]	
37	IOH	I	P0[0]	
38	IOH	I	P0[2]	
39	IOH	I	P0[4]	
40	IOH	I	P0[6]	
41	Power		Vdd	Supply voltage
42			NC	No connection
43			NC	No connection
44	IOH	I	P0[7]	
45	IOH	I	P0[5]	
46	IOH	I	P0[3]	Integrating input
47	Power		Vss	Ground connection
48	IOH	I	P0[1]	
CP	Power		Vss	Center pad must be connected to ground

LEGEND A = Analog, I = Input, O = Output, NC = No Connection H = 5 mA High Output Drive, R = Regulated Output.

48-Pin QFN OCD

The 48-pin QFN part is for the CY8C20066 On-Chip Debug (OCD) PSoC device. Note that this part is only used for in-circuit debugging.^[4]

Table 10. Pin Definitions - CY8C20066 PSoC Device ^[2, 3]

Pin No.	Digital	Analog	Name	Description
1			OCDOE	OCD mode direction pin
2	I/O	I	P2[7]	
3	I/O	I	P2[5]	Crystal output (XOut)
4	I/O	I	P2[3]	Crystal input (XIn)
5	I/O	I	P2[1]	
6	I/O	I	P4[3]	
7	I/O	I	P4[1]	
8	I/O	I	P3[7]	
9	I/O	I	P3[5]	
10	I/O	I	P3[3]	
11	I/O	I	P3[1]	
12	IOHR	I	P1[7]	I2C SCL, SPI SS
13	IOHR	I	P1[5]	I2C SDA, SPI MISO
14			CCLK	OCD CPU clock output
15			HCLK	OCD high speed clock output
16	IOHR	I	P1[3]	SPI CLK.
17	IOHR	I	P1[1]	ISSP CLK ⁽¹⁾ , I2C SCL, SPI MOSI
18	Power		Vss	Ground connection
19	I/O		D+	USB D+
20	I/O		D-	USB D-
21	Power		Vdd	Supply voltage
22	IOHR	I	P1[0]	ISSP DATA ⁽¹⁾ , I2C SDA, SPI CLK
23	IOHR	I	P1[2]	
24	IOHR	I	P1[4]	Optional external clock input (EXTCLK)
25	IOHR	I	P1[6]	
26	Input		XRES	Active high external reset with internal pull down
27	I/O	I	P3[0]	
28	I/O	I	P3[2]	
29	I/O	I	P3[4]	
30	I/O	I	P3[6]	
31	I/O	I	P4[0]	
32	I/O	I	P4[2]	
33	I/O	I	P2[0]	
34	I/O	I	P2[2]	
35	I/O	I	P2[4]	
36	I/O	I	P2[6]	

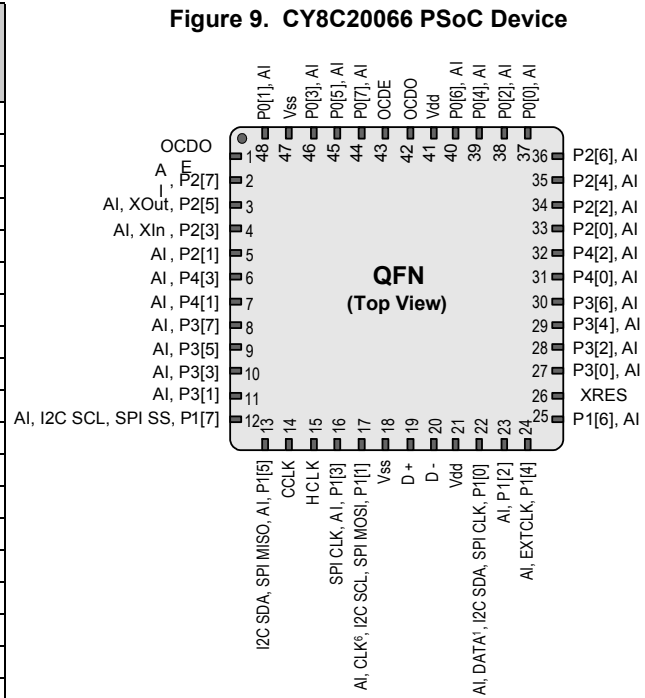

Pin No.	Digital	Analog	Name	Description
37	IOH	I	P0[0]	
38	IOH	I	P0[2]	
39	IOH	I	P0[4]	
40	IOH	I	P0[6]	
41	Power		Vdd	Supply voltage
42			OCDO	OCD even data I/O
43			OCDE	OCD odd data output
44	IOH	I	P0[7]	
45	IOH	I	P0[5]	
46	IOH	I	P0[3]	Integrating input
47	Power		Vss	Ground connection
48	IOH	I	P0[1]	
CP	Power		Vss	Center pad must be connected to ground

LEGEND A = Analog, I = Input, O = Output, NC = No Connection H = 5 mA High Output Drive, R = Regulated Output.

Note

4. This part is available in limited quantities for In-Circuit Debugging during prototype development. It is not available in production volumes.

Electrical Specifications

This section presents the DC and AC electrical specifications of the CY8C20x36/46/66/96 PSoC devices. For the latest electrical specifications, confirm that you have the most recent data sheet by visiting the web at <http://www.cypress.com/psoc>.

Figure 10. Voltage versus CPU Frequency

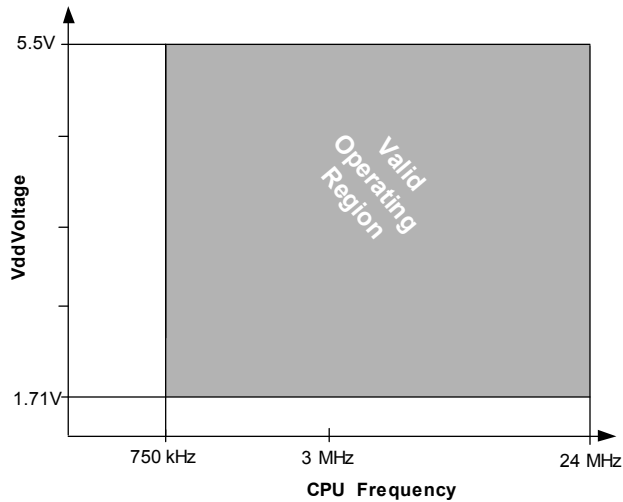
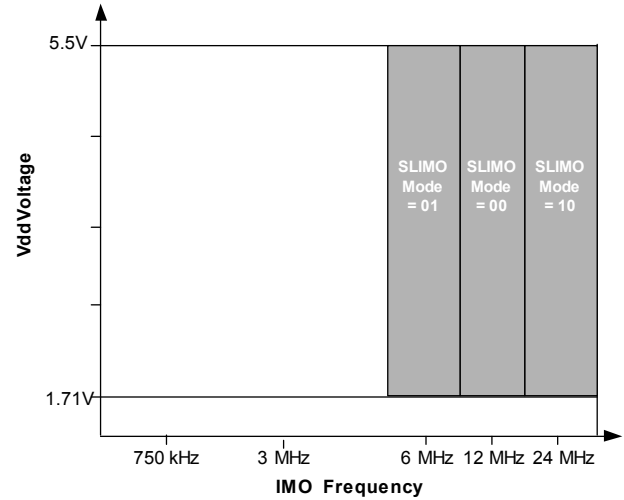

Figure 11. IMO Frequency Trim Options



The following table lists the units of measure that are used in this section.

Table 11. Units of Measure

Symbol	Unit of Measure	Symbol	Unit of Measure
°C	degree Celsius	mA	milli-ampere
dB	decibels	ms	milli-second
fF	femto farad	mV	milli-volts
Hz	hertz	nA	nanoampere
KB	1024 bytes	ns	nanosecond
Kbit	1024 bits	nV	nanovolts
kHz	kilohertz	Ω	ohm
ksps	kilo samples per second	pA	picoampere
kΩ	kilohm	pF	picofarad
MHz	megahertz	pp	peak-to-peak
MΩ	megaohm	ppm	parts per million
μA	microampere	ps	picosecond
μF	microfarad	sps	samples per second
μH	microhenry	s	sigma: one standard deviation
μs	microsecond	V	volts
μW	microwatts		

Absolute Maximum Ratings

Exceeding maximum ratings may shorten the useful life of the device. User guidelines are not tested.

Table 12. Absolute Maximum Ratings

Symbol	Description	Conditions	Min	Typ	Max	Units
T _{STG}	Storage Temperature	Higher storage temperatures reduces data retention time. Recommended Storage Temperature is +25°C ± 25°C. Extended duration storage temperatures above 85°C degrades reliability.	-55	+25	+125	°C
V _{dd}	Supply Voltage Relative to V _{ss}		-0.5	-	+6.0	V
V _{IO}	DC Input Voltage		V _{ss} - 0.5	-	V _{dd} + 0.5	V
V _{IOZ}	DC Voltage Applied to Tri-state		V _{ss} - 0.5	-	V _{dd} + 0.5	V
I _{MIO}	Maximum Current into any Port Pin		-25	-	+50	mA
ESD	Electro Static Discharge Voltage	Human Body Model ESD	2000	-	-	V
LU	Latch up Current	In accordance with JESD78 standard	-	-	200	mA

Operating Temperature

Table 13. Operating Temperature

Symbol	Description	Conditions	Min	Typ	Max	Units
T _A	Ambient Temperature		-40	-	+85	°C
T _J	Operational Die Temperature	The temperature rise from ambient to junction is package specific. Refer the table Thermal Impedances per Package on page 34 . The user must limit the power consumption to comply with this requirement.	-40	-	+100	°C

DC Chip-Level Specifications

The following table lists guaranteed maximum and minimum specifications for the entire voltage and temperature ranges.

Table 14. DC Chip-Level Specifications

Symbol	Description	Conditions	Min	Typ	Max	Units
V _{DD}	Supply Voltage	Refer the table DC POR and LVD Specifications on page 24	1.71	–	5.5	V
I _{DD24}	Supply Current, IMO = 24 MHz	Conditions are V _{DD} = 3.0V, T _A = 25°C, CPU = 24 MHz. CapSense running at 12 MHz, no I/O sourcing current	–	2.88	4.0	mA
I _{DD12}	Supply Current, IMO = 12 MHz	Conditions are V _{DD} = 3.0V, T _A = 25°C, CPU = 12 MHz. CapSense running at 12 MHz, no I/O sourcing current	–	1.71	2.6	mA
I _{DD6}	Supply Current, IMO = 6 MHz	Conditions are V _{DD} = 3.0V, T _A = 25°C, CPU = 6 MHz. CapSense running at 6 MHz, no I/O sourcing current	–	1.16	1.8	mA
I _{SB0}	Deep Sleep Current	V _{DD} = 3.0V, T _A = 25°C, I/O regulator turned off	–	0.1	–	μA
I _{SB1}	Standby Current with POR, LVD and Sleep Timer	V _{DD} = 3.0V, T _A = 25°C, I/O regulator turned off	–	1.07	1.5	μA

DC General Purpose IO Specifications

The following tables list guaranteed maximum and minimum specifications for the voltage and temperature ranges: 3.0V to 5.5V and –40°C ≤ T_A ≤ 85°C, 2.4V to 3.0V and –40°C ≤ T_A ≤ 85°C, or 1.71V to 2.4V and –40°C ≤ T_A ≤ 85°C, respectively. Typical parameters apply to 5V and 3.3V at 25°C and are for design guidance only.

Table 15. 3.0V to 5.5V DC GPIO Specifications

Symbol	Description	Conditions	Min	Typ	Max	Units
R _{PU}	Pull up Resistor		4	5.6	8	kΩ
V _{OH1}	High Output Voltage Port 2 or 3 Pins	I _{OH} ≤ 10 μA, maximum of 10 mA source current in all IOs	V _{DD} - 0.2	–	–	V
V _{OH2}	High Output Voltage Port 2 or 3 Pins	I _{OH} = 1 mA, maximum of 20 mA source current in all IOs	V _{DD} - 0.9	–	–	V
V _{OH3}	High Output Voltage Port 0 or 1 Pins with LDO Regulator Disabled for Port 1	I _{OH} < 10 μA, maximum of 10 mA source current in all IOs	V _{DD} - 0.2	–	–	V
V _{OH4}	High Output Voltage Port 0 or 1 Pins with LDO Regulator Disabled for Port 1	I _{OH} = 5 mA, maximum of 20 mA source current in all IOs	V _{DD} - 0.9	–	–	V
V _{OH5}	High Output Voltage Port 1 Pins with LDO Regulator Enabled for 3V Out	I _{OH} < 10 μA, V _{DD} > 3.1V, maximum of 4 IOs all sourcing 5 mA	2.85	3.00	3.3	V
V _{OH6}	High Output Voltage Port 1 Pins with LDO Regulator Enabled for 3V Out	I _{OH} = 5 mA, V _{DD} > 3.1V, maximum of 20 mA source current in all IOs	2.20	–	–	V
V _{OH7}	High Output Voltage Port 1 Pins with LDO Enabled for 2.5V Out	I _{OH} < 10 μA, V _{DD} > 2.7V, maximum of 20 mA source current in all IOs	2.35	2.50	2.75	V
V _{OH8}	High Output Voltage Port 1 Pins with LDO Enabled for 2.5V Out	I _{OH} = 2 mA, V _{DD} > 2.7V, maximum of 20 mA source current in all IOs	1.90	–	–	V
V _{OH9}	High Output Voltage Port 1 Pins with LDO Enabled for 1.8V Out	I _{OH} < 10 μA, V _{DD} > 2.7V, maximum of 20 mA source current in all IOs	1.60	1.80	2.1	V

Table 15. 3.0V to 5.5V DC GPIO Specifications (continued)

Symbol	Description	Conditions	Min	Typ	Max	Units
V _{OH10}	High Output Voltage Port 1 Pins with LDO Enabled for 1.8V Out	IOH = 1 mA, V _{dd} > 2.7V, maximum of 20 mA source current in all IOs	1.20	–	–	V
V _{OL}	Low Output Voltage	IOL = 25 mA, V _{dd} > 3.3V, maximum of 60 mA sink current on even port pins (for example, P0[2] and P1[4]) and 60 mA sink current on odd port pins (for example, P0[3] and P1[5])	–	–	0.75	V
V _{IL}	Input Low Voltage		–	–	0.80	V
V _{IH}	Input High Voltage		2.00	–		V
V _H	Input Hysteresis Voltage		–	80	–	mV
I _{IL}	Input Leakage (Absolute Value)		–	0.001	1	μA
C _{PIN}	Pin Capacitance	Package and pin dependent Temp = 25°C	0.5	1.7	5	pF

Table 16. 2.4V to 3.0V DC GPIO Specifications

Symbol	Description	Conditions	Min	Typ	Max	Units
R _{PU}	Pull up Resistor		4	5.6	8	kΩ
V _{OH1}	High Output Voltage Port 2 or 3 Pins	I _{OH} < 10 μA, maximum of 10 mA source current in all IOs	V _{dd} - 0.2	–	–	V
V _{OH2}	High Output Voltage Port 2 or 3 Pins	I _{OH} = 0.2 mA, maximum of 10 mA source current in all IOs	V _{dd} - 0.4	–	–	V
V _{OH3}	High Output Voltage Port 0 or 1 Pins with LDO Regulator Disabled for Port 1	I _{OH} < 10 μA, maximum of 10 mA source current in all IOs	V _{dd} - 0.2	–	–	V
V _{OH4}	High Output Voltage Port 0 or 1 Pins with LDO Regulator Disabled for Port 1	I _{OH} = 2 mA, maximum of 10 mA source current in all IOs	V _{dd} - 0.5	–	–	V
V _{OH5A}	High Output Voltage Port 1 Pins with LDO Enabled for 1.8V Out	I _{OH} < 10 μA, V _{dd} > 2.4V, maximum of 20 mA source current in all IOs	1.50	1.80	2.1	V
V _{OH6A}	High Output Voltage Port 1 Pins with LDO Enabled for 1.8V Out	I _{OH} = 1 mA, V _{dd} > 2.4V, maximum of 20 mA source current in all IOs	1.20	–	–	V
V _{OL}	Low Output Voltage	I _{OL} = 10 mA, maximum of 30 mA sink current on even port pins (for example, P0[2] and P1[4]) and 30 mA sink current on odd port pins (for example, P0[3] and P1[5])	–	–	0.75	V
V _{IL}	Input Low Voltage		–	–	0.72	V
V _{IH}	Input High Voltage		1.4	–	–	V
V _H	Input Hysteresis Voltage		–	80	–	mV
I _{IL}	Input Leakage (Absolute Value)		–	0.001	1	μA
C _{PIN}	Capacitive Load on Pins	Package and pin dependent Temp = 25°C	0.5	1.7	5	pF

Table 17. 1.71V to 2.4V DC GPIO Specifications

Symbol	Description	Conditions	Min	Typ	Max	Units
R _{PU}	Pull up Resistor		4	5.6	8	kΩ
V _{OH1}	High Output Voltage Port 2 or 3 Pins	I _{OH} = 10 μA, maximum of 10 mA source current in all I/Os	V _{dd} - 0.2	–	–	V
V _{OH2}	High Output Voltage Port 2 or 3 Pins	I _{OH} = 0.5 mA, maximum of 10 mA source current in all I/Os	V _{dd} - 0.5	–	–	V
V _{OH3}	High Output Voltage Port 0 or 1 Pins with LDO Regulator Disabled for Port 1	I _{OH} = 100 μA, maximum of 10 mA source current in all I/Os	V _{dd} - 0.2	–	–	V
V _{OH4}	High Output Voltage Port 0 or 1 Pins with LDO Regulator Disabled for Port 1	I _{OH} = 2 mA, maximum of 10 mA source current in all I/Os	V _{dd} - 0.5	–	–	V
V _{OL}	Low Output Voltage	I _{OL} = 5 mA, maximum of 20 mA sink current on even port pins (for example, P0[2] and P1[4]) and 30 mA sink current on odd port pins (for example, P0[3] and P1[5])	–	–	0.4	V
V _{IL}	Input Low Voltage		–	–	0.3 x V _{dd}	V
V _{IH}	Input High Voltage		0.65 x V _{dd}	–	–	V

Table 17. 1.71V to 2.4V DC GPIO Specifications (continued)

Symbol	Description	Conditions	Min	Typ	Max	Units
V _H	Input Hysteresis Voltage		–	80	–	mV
I _{IL}	Input Leakage (Absolute Value)		–	0.001	1	μA
C _{PIN}	Capacitive Load on Pins	Package and pin dependent Temp = 25°C	0.5	1.7	5	pF

Table 18. DC Characteristics – USB Interface

Symbol	Description	Conditions	Min	Typ	Max	Units
R _{usb}	USB D+ Pull Up Resistance	With idle bus	0.900	-	1.575	kΩ
R _{usb}	USB D+ Pull Up Resistance	While receiving traffic	1.425	-	3.090	kΩ
V _{ohusb}	Static Output High		2.8	-	3.6	V
V _{olusb}	Static Output Low			-	0.3	V
V _{di}	Differential Input Sensitivity		0.2	-		V
V _{cm}	Differential Input Common Mode Range		0.8	-	2.5	V
V _{se}	Single Ended Receiver Threshold		0.8	-	2.0	V
C _{in}	Transceiver Capacitance			-	50	pF
I _{io}	Hi-Z State Data Line Leakage	On D+ or D- line	-10	-	+10	μA
R _{ps2}	PS/2 Pull Up Resistance		3	5	7	kΩ
R _{ext}	External USB Series Resistor	In series with each USB pin	21.78	22.0	22.22	Ω

DC Analog Mux Bus Specifications

The following table lists guaranteed maximum and minimum specifications for the entire voltage and temperature ranges.

Table 19. DC Analog Mux Bus Specifications

Symbol	Description	Conditions	Min	Typ	Max	Units
R _{SW}	Switch Resistance to Common Analog Bus		–	–	800	Ω
R _{GND}	Resistance of Initialization Switch to V _{SS}		–	–	800	Ω

The maximum pin voltage for measuring R_{SW} and R_{GND} is 1.8V

DC Low Power Comparator Specifications

The following table lists guaranteed maximum and minimum specifications for the entire voltage and temperature ranges.

Table 20. DC Comparator Specifications

Symbol	Description	Conditions	Min	Typ	Max	Units
V _{LPC}	Low Power Comparator (LPC) common mode	Maximum voltage limited to V _{DD}	0.0	–	1.8	V
I _{LPC}	LPC supply current		–	10	40	μA
V _{OSLPC}	LPC voltage offset		–	2.5	30	mV

Comparator User Module Electrical Specifications

The following table lists the guaranteed maximum and minimum specifications. Unless stated otherwise, the specifications are for the entire device voltage and temperature operating range: $-40^{\circ}\text{C} \leq \text{TA} \leq 85^{\circ}\text{C}$, $1.71\text{V} \leq \text{Vdd} \leq 5.5\text{V}$.

Table 21. Comparator User Module Electrical Specifications

Symbol	Description	Conditions	Min	Typ	Max	Units
T _{COMP}	Comparator Response Time	50 mV overdrive		70	100	ns
Offset				2.5	30	mV
Current		Average DC current, 50 mV overdrive		20	80	μA
PSRR	Supply voltage >2V	Power Supply Rejection Ratio		80		dB
	Supply voltage <2V	Power Supply Rejection Ratio		40		dB
Input Range			0		1.5	V

ADC Electrical Specifications

Table 22. ADC User Module Electrical Specifications

Symbol	Description	Conditions	Min	Typ	Max	Units
Input						
V _{IN}	Input Voltage Range	This gives 72% of maximum code	V _{SS}		1.3	V
C _{IN}	Input Capacitance				5	pF
RES	Resolution	Settings 8, 9, or 10	8		10	Bits
S8	8-Bit Sample Rate	Data Clock set to 6 MHz. Sample Rate = 0.001/ (2 ^{Resolution} /Data clock)		23.4375		ksps
S10	10-Bit Sample Rate	Data Clock set to 6 MHz. Sample Rate = 0.001/ (2 ^{Resolution} /Data clock)		5.859		ksps
DC Accuracy						
DNL ^[5]	Differential Nonlinearity	For any configuration	-1		+2	LSB
INL	Integral Nonlinearity	For any configuration	-2		+2	LSB
Eoffset	Offset Error		0	15	90	mV
I _{ADC}	Operating Current			275	350	μA
F _{CLK}	Data Clock	Source is chip's internal main oscillator. See device data sheet for accuracy.	2.25		12	MHz
PSRR	Power Supply Rejection Ration					
	PSRR (V _{dd} >3.0V)			24		dB
	PSRR (2.2 < V _{dd} < 3.0)			30		dB
	PSRR (2.0 < V _{dd} < 2.2)			12		dB
	PSRR (V _{dd} < 2.0)			0		dB
E _{gain}	Gain Error	For any resolution	1		5	%FSR
R _{IN}	Input Resistance	Equivalent switched cap input resistance for 8-, 9-, or 10-bit resolution.	1/(500fF* Data-Clock)	1/(400fF* Data-Clock)	1/(300fF* Data-Clock)	Ω

Note

5. Monotonicity is not guaranteed.

DC POR and LVD Specifications

The following table lists guaranteed maximum and minimum specifications for the entire voltage and temperature ranges.

Table 23. DC POR and LVD Specifications

Symbol	Description	Conditions	Min	Typ	Max	Units
V _{PPOR0}	Vdd Value for PPOR Trip PORLEV[1:0] = 00b, HPOR = 0	Vdd must be greater than or equal to 1.71V during startup, reset from the XRES pin, or reset from watchdog.	1.61	1.66	1.71	V
V _{PPOR1}	PORLEV[1:0] = 00b, HPOR = 1		–	2.36	2.41	V
V _{PPOR2}	PORLEV[1:0] = 01b, HPOR = 1		–	2.60	2.66	V
V _{PPOR3}	PORLEV[1:0] = 10b, HPOR = 1		–	2.82	2.95	V
V _{LVD0}	Vdd Value for LVD Trip VM[2:0] = 000b		2.40 ^[6]	2.45	2.51	V
V _{LVD1}	VM[2:0] = 001b		2.64 ^[7]	2.71	2.78	V
V _{LVD2}	VM[2:0] = 010b		2.85 ^[8]	2.92	2.99	V
V _{LVD3}	VM[2:0] = 011b		2.95	3.02	3.09	V
V _{LVD4}	VM[2:0] = 100b		3.06	3.13	3.20	V
V _{LVD5}	VM[2:0] = 101b		1.84	1.90	2.32	V
V _{LVD6}	VM[2:0] = 110b		1.75 ^[9]	1.80	1.84	V
V _{LVD7}	VM[2:0] = 111b		4.62	4.73	4.83	V

DC Programming Specifications

The following table lists guaranteed maximum and minimum specifications for the entire voltage and temperature ranges.

Table 24. DC Programming Specifications

Symbol	Description	Conditions	Min	Typ	Max	Units
V _{ddIWRITE}	Supply Voltage for Flash Write Operations		1.71	–	5.25	V
I _{DDP}	Supply Current During Programming or Verify		–	5	25	mA
V _{ILP}	Input Low Voltage During Programming or Verify	See the appropriate DC General Purpose IO Specifications on page 19	–	–	V _{IL}	V
V _{IHP}	Input High Voltage During Programming or Verify	See appropriate DC General Purpose IO Specifications on page 19 table on pages 15 or 16	V _{IH}	–	–	V
I _{ILP}	Input Current when Applying Vilp to P1[0] or P1[1] During Programming or Verify	Driving internal pull down resistor	–	–	0.2	mA
I _{IHP}	Input Current when Applying Vihp to P1[0] or P1[1] During Programming or Verify	Driving internal pull down resistor	–	–	1.5	mA
V _{OLP}	Output Low Voltage During Programming or Verify		–	–	V _{ss} + 0.75	V
V _{OHP}	Output High Voltage During Programming or Verify	See appropriate DC General Purpose IO Specifications on page 19 table on page 16. For Vdd > 3V use V _{OH4} in Table 13 on page 18 .	V _{OH}	–	V _{dd}	V
Flash _{ENPB}	Flash Write Endurance	Erase/write cycles per block	50,000	–	–	-
Flash _{DR}	Flash Data Retention	Following maximum Flash write cycles; ambient temperature of 55°C	10	20	–	Years

Notes

6. Always greater than 50 mV above V_{PPOR1} voltage for falling supply.
7. Always greater than 50 mV above V_{PPOR2} voltage for falling supply.
8. Always greater than 50 mV above V_{PPOR3} voltage for falling supply.
9. Always greater than 50 mV above V_{PPOR0} voltage for falling supply.

AC Chip-Level Specifications

The following table lists guaranteed maximum and minimum specifications for the entire voltage and temperature ranges.

Table 25. AC Chip-Level Specifications

Symbol	Description	Conditions	Min	Typ	Max	Units
F _{CPU}	CPU Frequency		5.7	–	25.2	MHz
F _{32K1}	Internal Low Speed Oscillator Frequency		19	32	50	kHz
F _{IMO24}	Internal Main Oscillator Frequency at 24 MHz Setting		22.8	24	25.2	MHz
F _{IMO12}	Internal Main Oscillator Frequency at 12 MHz Setting		11.4	12	12.6	MHz
F _{IMO6}	Internal Main Oscillator Frequency at 6 MHz Setting		5.7	6.0	6.3	MHz
DC _{IMO}	Duty Cycle of IMO		40	50	60	%
T _{RAMP}	Supply Ramp Time		20	–	–	μs
T _{XRST}	External Reset Pulse Width at Power Up	After supply voltage is valid	1			ms
T _{XRST2}	External Reset Pulse Width after Power Up ^[10]	Applies after part has booted	10			μs

Note

10. The minimum required XRES pulse length is longer when programming the device (see [Table 32 on page 28](#)).

AC General Purpose IO Specifications

The following table lists guaranteed maximum and minimum specifications for the entire voltage and temperature ranges.

Table 26. AC GPIO Specifications

Symbol	Description	Conditions	Min	Typ	Max	Units
F _{GPIO}	GPIO Operating Frequency	Normal Strong Mode Port 0, 1	0	–	6 MHz for 1.71V<V _{dd} <2.4V 12 MHz for 2.4V<V _{dd} <5.5V	MHz
TRise23	Rise Time, Strong Mode, Cload = 50 pF Ports 2 or 3	V _{dd} = 3.0 to 3.6V, 10% – 90%	15	–	80	ns
TRise23L	Rise Time, Strong Mode Low Supply, Cload = 50 pF, Ports 2 or 3	V _{dd} = 1.71 to 3.0V, 10% – 90%	15	–	80	ns
TRise01	Rise Time, Strong Mode, Cload = 50 pF Ports 0 or 1	V _{dd} = 3.0 to 3.6V, 10% – 90% LDO enabled or disabled	10	–	50	ns
TRise01L	Rise Time, Strong Mode Low Supply, Cload = 50 pF, Ports 0 or 1	V _{dd} = 1.71 to 3.0V, 10% – 90% LDO enabled or disabled	10	–	80	ns
TFall	Fall Time, Strong Mode, Cload = 50 pF All Ports	V _{dd} = 3.0 to 3.6V, 10% – 90%	10	–	50	ns
TFallL	Fall Time, Strong Mode Low Supply, Cload = 50 pF, All Ports	V _{dd} = 1.71 to 3.0V, 10% – 90%	10	–	70	ns

Figure 12. GPIO Timing Diagram

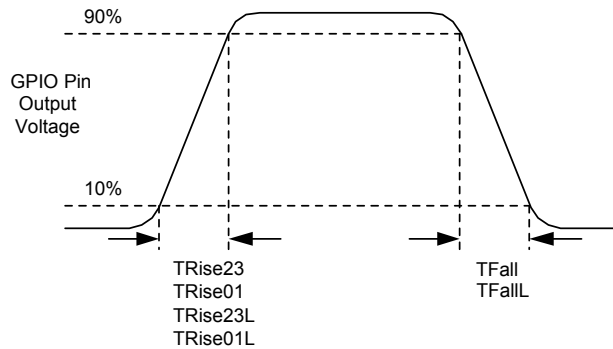

Table 27.AC Characteristics – USB Data Timings

Symbol	Description	Conditions	Min	Typ	Max	Units
Td _{rate}	Full speed data rate	Average bit rate	12-0.25%	12	12 + 0.25%	MHz
Td _{jr1}	Receiver data jitter tolerance	To next transition	-18.5	–	18.5	ns
Td _{jr2}	Receiver data jitter tolerance	To pair transition	-9	–	9	ns
Tud _{j1}	Driver differential jitter	To next transition	-3.5	–	3.5	ns
Tud _{j2}	Driver differential jitter	To pair transition	-4.0	–	4.0	ns
Tf _{deop}	Source jitter for differential transition	To SE0 transition	-2	–	5	ns
Tf _{eopt}	Source SE0 interval of EOP		160	–	175	ns
Tf _{eopr}	Receiver SE0 interval of EOP		82	–		ns
Tf _{st}	Width of SE0 interval during differential transition			–	14	ns

Table 28.AC Characteristics – USB Driver

Symbol	Description	Conditions	Min	Typ	Max	Units
T _r	Transition rise time	50 pF	4	–	20	ns
T _f	Transition fall time	50 pF	4	–	20	ns
T _R	Rise/fall time matching		90.00	–	111.1	%
V _{crs}	Output signal crossover voltage		1.3	–	2.0	V

AC Comparator Specifications

The following table lists guaranteed maximum and minimum specifications for the entire voltage and temperature ranges.

Table 29. AC Low Power Comparator Specifications

Symbol	Description	Conditions	Min	Typ	Max	Units
T _{LPC}	Comparator Response Time, 50 mV Overdrive	50 mV overdrive does not include offset voltage.			100	ns

AC Analog Mux Bus Specifications

The following table lists guaranteed maximum and minimum specifications for the entire voltage and temperature ranges.

Table 30. AC Analog Mux Bus Specifications

Symbol	Description	Conditions	Min	Typ	Max	Units
F _{SW}	Switch Rate	Maximum pin voltage when measuring switch rate is 1.8Vp-p	–	–	6.3	MHz

AC External Clock Specifications

The following table lists guaranteed maximum and minimum specifications for the entire voltage and temperature ranges.

Table 31. AC External Clock Specifications

Symbol	Description	Conditions	Min	Typ	Max	Units
F _{OSCEXT}	Frequency		0.750	–	25.2	MHz
–	High Period		20.6	–	5300	ns
–	Low Period		20.6	–	–	ns
–	Power Up IMO to Switch		150	–	–	μs

AC Programming Specifications

Figure 13. AC Waveform

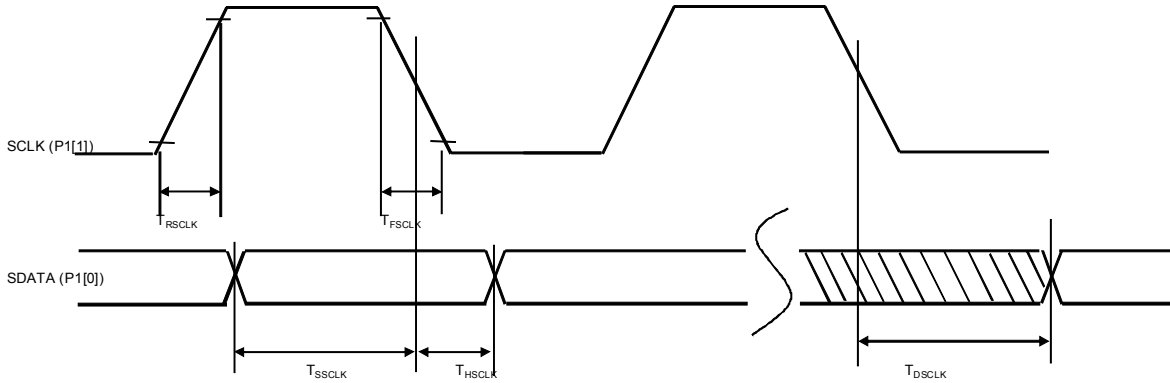

The following table lists the guaranteed maximum and minimum specifications for the entire voltage and temperature ranges.

Table 32. AC Programming Specifications

Symbol	Description	Conditions	Min	Typ	Max	Units
T_{R_SCLK}	Rise Time of SCLK		1	–	20	ns
T_{F_SCLK}	Fall Time of SCLK		1	–	20	ns
T_{SSCLK}	Data Set up Time to Falling Edge of SCLK		40	–	–	ns
T_{HSCLK}	Data Hold Time from Falling Edge of SCLK		40	–	–	ns
F_{SCLK}	Frequency of SCLK		0	–	8	MHz
T_{ERASEB}	Flash Erase Time (Block)		–	–	18	ms
T_{WRITE}	Flash Block Write Time		–	–	25	ms
T_{D_SCLK}	Data Out Delay from Falling Edge of SCLK	$3.6 < V_{dd}$	–	–	60	ns
T_{D_SCLK3}	Data Out Delay from Falling Edge of SCLK	$3.0 \leq V_{dd} \leq 3.6$	–	–	85	ns
T_{D_SCLK2}	Data Out Delay from Falling Edge of SCLK	$1.71 \leq V_{dd} \leq 3.0$	–	–	130	ns
T_{XRST3}	External Reset Pulse Width after Power Up	Required to enter programming mode when coming out of sleep	263	–	–	μ s

AC I2C Specifications

The following table lists guaranteed maximum and minimum specifications for the entire voltage and temperature ranges.

Table 33. AC Characteristics of the I2C SDA and SCL Pins

Symbol	Description	Standard Mode		Fast Mode		Units
		Min	Max	Min	Max	
$F_{SCL I2C}$	SCL Clock Frequency	0	100	0	400	kHz
$T_{HDSTAI2C}$	Hold Time (repeated) START Condition. After this period, the first clock pulse is generated.	4.0	–	0.6	–	μ s
T_{LOWI2C}	LOW Period of the SCL Clock	4.7	–	1.3	–	μ s
$T_{HIGHI2C}$	HIGH Period of the SCL Clock	4.0	–	0.6	–	μ s
$T_{SUSTAI2C}$	Setup Time for a Repeated START Condition	4.7	–	0.6	–	μ s
$T_{HDDATI2C}$	Data Hold Time	0	–	0	–	μ s
$T_{SUDATI2C}$	Data Setup Time	250	–	100 ^[11]	–	ns
$T_{SUSTOI2C}$	Setup Time for STOP Condition	4.0	–	0.6	–	μ s
T_{BUFI2C}	Bus Free Time Between a STOP and START Condition	4.7	–	1.3	–	μ s
T_{SPI2C}	Pulse Width of spikes are suppressed by the input filter.	–	–	0	50	ns

Figure 14. Definition for Timing for Fast/Standard Mode on the I2C Bus

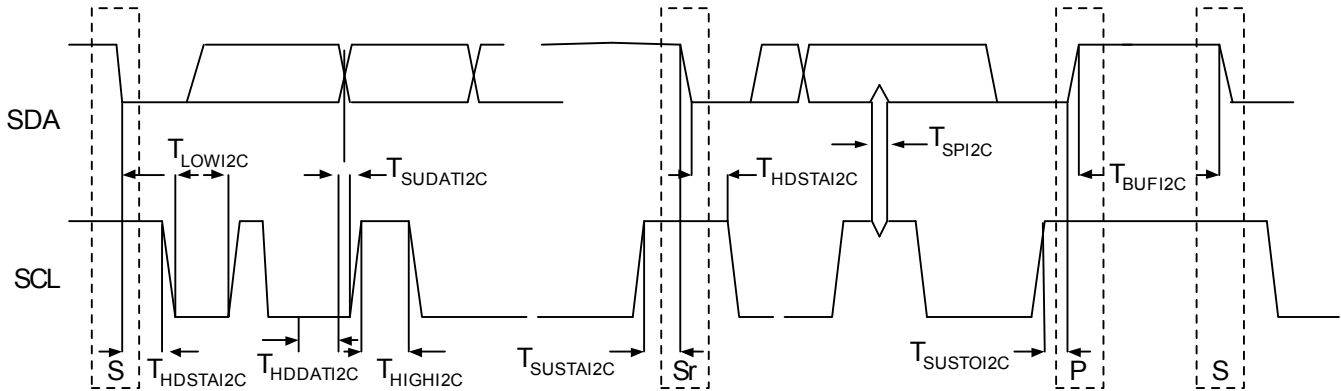

Note

11. A Fast-Mode I2C-bus device can be used in a Standard Mode I2C-bus system, but the requirement $t_{SU,DAT} \geq 250$ ns must then be met. This automatically be the case if the device does not stretch the LOW period of the SCL signal. If such device does stretch the LOW period of the SCL signal, it must output the next data bit to the SDA line $t_{rmax} + t_{SU,DAT} = 1000 + 250 = 1250$ ns (according to the Standard-Mode I2C-bus specification) before the SCL line is released.

Table 34. SPI Master AC Specifications

Symbol	Description	Conditions	Min	Typ	Max	Units
F _{SCLK}	SCLK clock frequency	V _{DD} ≥ 2.4V V _{DD} < 2.4V			6 3	MHz
DC	SCLK duty cycle			50		%
T _{SETUP}	MISO to SCLK setup time	V _{DD} ≥ 2.4V V _{DD} < 2.4V	60 100			ns
T _{HOLD}	SCLK to MISO hold time		40			ns
T _{OUT_VAL}	SCLK to MOSI valid time				40	ns
T _{OUT_HIGH}	MOSI high time		40			ns

Table 35. SPI Slave AC Specifications

Symbol	Description	Conditions	Min	Typ	Max	Units
F _{SCLK}	SCLK clock frequency	V _{DD} ≥ 2.4V V _{DD} < 2.4V			12 6	MHz
T _{LOW}	SCLK low time		41.67			ns
T _{HIGH}	SCLK high time		41.67			ns
T _{SETUP}	MOSI to SCLK setup time		30			ns
T _{HOLD}	SCLK to MOSI hold time		50			ns
T _{SS_MISO}	SS high to MISO valid				153	ns
T _{SCLK_MISO}	SCLK to MISO valid				125	ns
T _{SS_HIGH}	SS high time				50	ns
T _{SS_CLK}	Time from SS low to first SCLK		2/SCLK			ns
T _{CLK_SS}	Time from last SCLK to SS high		2/SCLK			ns

Packaging Information

This section illustrates the packaging specifications for the CY8C20x36/46/66/96 PSoC device, along with the thermal impedances for each package.

Important Note Emulation tools may require a larger area on the target PCB than the chip's footprint. For a detailed description of the emulation tools' dimensions, refer to the document titled *PSoC Emulator Pod Dimensions* at <http://www.cypress.com/design/MR10161>.

Figure 15. 16-pin QFN No E-pad 3x3mm Package Outline (Sawn)

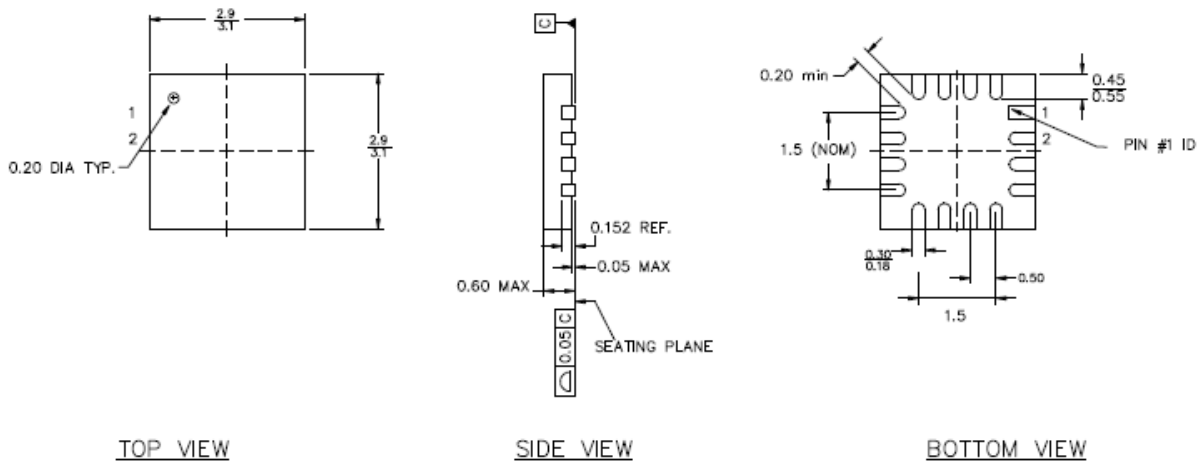

PART NO.	DESCRIPTION
LG16A	LEAD-FREE
LD16A	STANDARD

NOTES:

1. JEDEC # MD-220
2. Package Weight: 0.014g
3. DIMENSIONS IN MM, MIN MAX

001-09116 *D

Figure 16. 24-Pin (4x4 x 0.6 mm) QFN

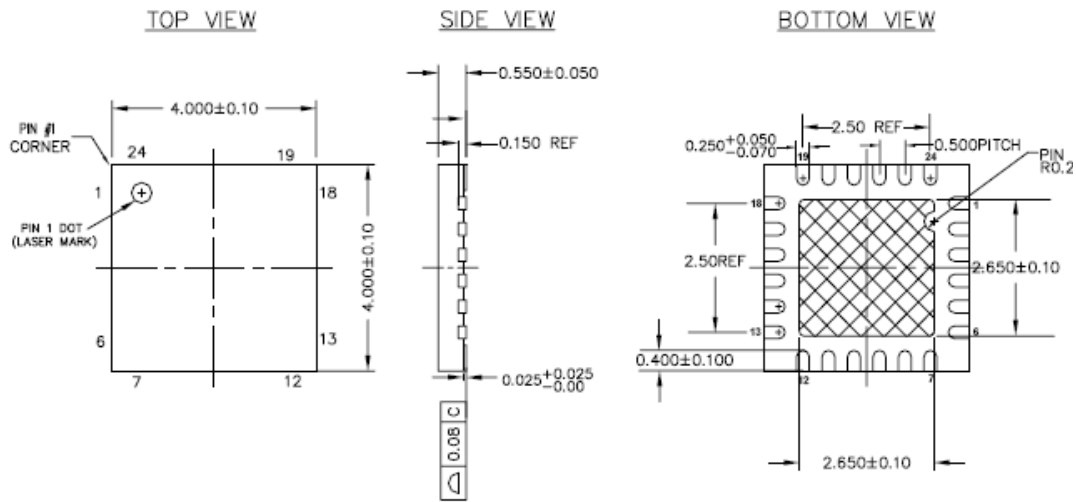

NOTES :

1.  HATCH IS SOLDERABLE EXPOSED METAL.
2. REFERENCE JEDEC # MO-248
3. UNIT PACKAGE WEIGHT : 0.024 grams
4. ALL DIMENSIONS ARE IN MILLIMETERS

001-13937 *B

Figure 17. 32-Pin (5x5 x 0.6 mm) QFN

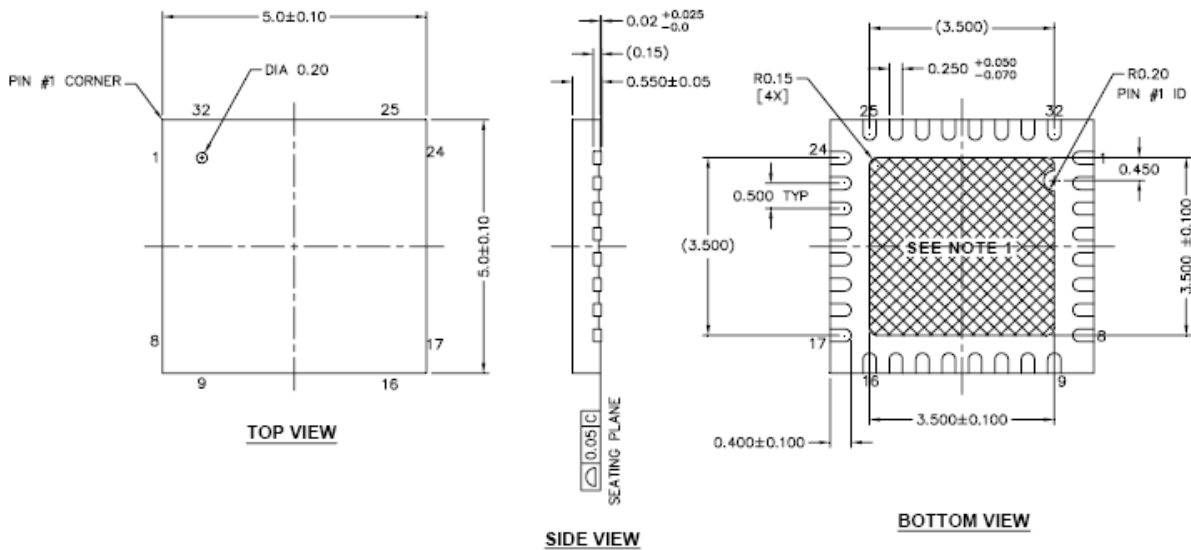

NOTES:

1.  HATCH AREA IS SOLDERABLE EXPOSED PAD
2. BASED ON REF JEDEC # MO-248
3. PACKAGE WEIGHT: 0.0388g
4. DIMENSIONS ARE IN MILLIMETERS

001-42168 *C

Figure 18. 48-Pin (300 MIL) SSOP

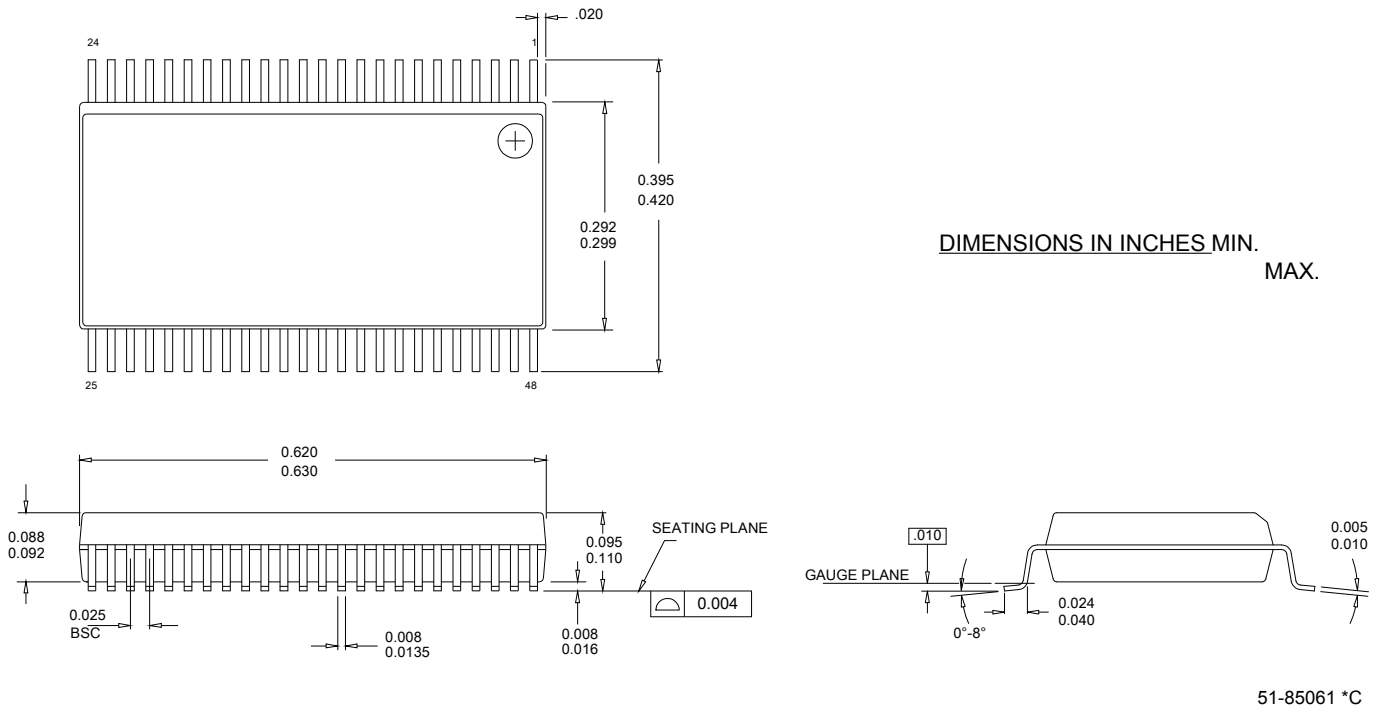
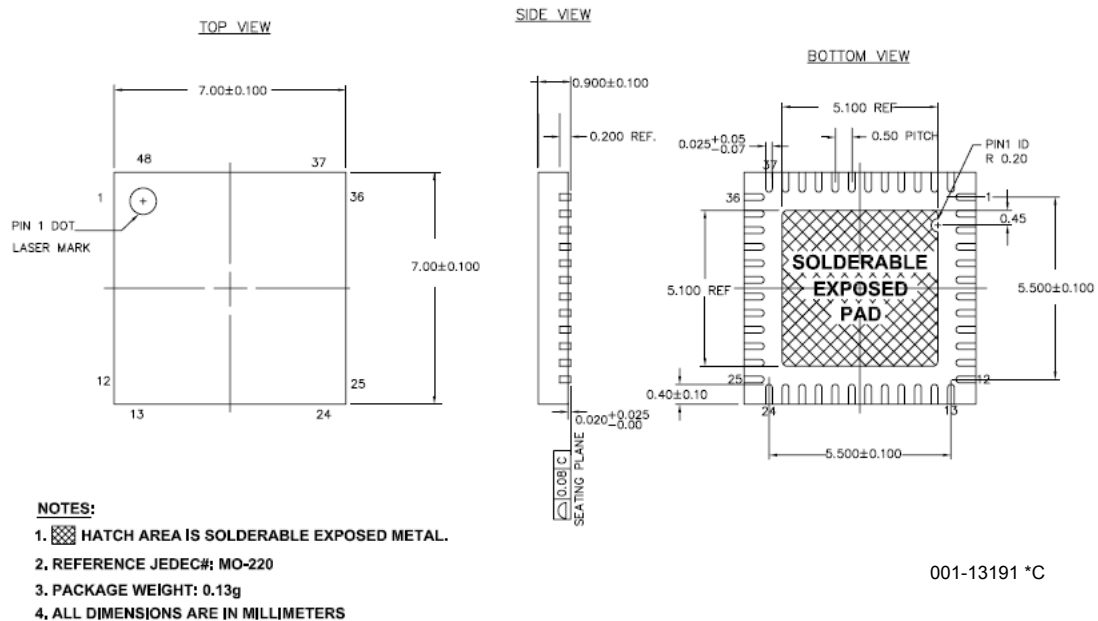

Figure 19. 48-Pin (7x7 mm) QFN



Important Notes

- For information on the preferred dimensions for mounting QFN packages, see the following Application Note at http://www.amkor.com/products/notes_papers/MLFAppNote.pdf.
- Pinned vias for thermal conduction are not required for the low power PSoC device.

Thermal Impedances

Table 36. Thermal Impedances per Package

Package	Typical θ_{JA} [12]
16 QFN	32.69°C/W
24 QFN ^[13]	20.90°C/W
32 QFN ^[13]	19.51°C/W
48 SSOP	69°C/W
48 QFN ^[13]	17.68°C/W

Solder Reflow Peak Temperature

This table lists the minimum solder reflow peak temperature to achieve good solderability.

Table 37. Solder Reflow Peak Temperature

Package	Minimum Peak Temperature ^[14]	Maximum Peak Temperature
16 QFN	240°C	260°C
24 QFN	240°C	260°C
32 QFN	240°C	260°C
48 SSOP	220°C	260°C
48 QFN	240°C	260°C

Notes

12. $T_J = T_A + \text{Power} \times \theta_{JA}$.

13. To achieve the thermal impedance specified for the QFN package, the center thermal pad must be soldered to the PCB ground plane.

14. Higher temperatures may be required based on the solder melting point. Typical temperatures for solder are $220 \pm 5^\circ\text{C}$ with Sn-Pb or $245 \pm 5^\circ\text{C}$ with Sn-Ag-Cu paste. Refer to the solder manufacturer specifications.

Development Tool Selection

Software

PSoC Designer™

At the core of the PSoC development software suite is PSoC Designer, used to generate PSoC firmware applications. PSoC Designer is available free of charge at <http://www.cypress.com/psocdesigner> and includes a free C compiler.

PSoC Programmer

PSoC Programmer is flexible enough and is used on the bench in development and is also suitable for factory programming. PSoC Programmer works either as a standalone programming application or operates directly from PSoC Designer or PSoC Express. PSoC Programmer software is compatible with both PSoC ICE Cube In-Circuit Emulator and PSoC MiniProg. PSoC programmer is available free of cost at <http://www.cypress.com/psocprogrammer>.

Development Kits

All development kits are sold at the Cypress Online Store.

CY3215-DK Basic Development Kit

The CY3215-DK is for prototyping and development with PSoC Designer. This kit supports in-circuit emulation and the software interface enables users to run, halt, and single step the processor and view the content of specific memory locations. PSoC Designer supports the advance emulation features also. The kit includes:

- PSoC Designer Software CD
- ICE-Cube In-Circuit Emulator
- ICE Flex-Pod for CY8C29x66 Family
- Cat-5 Adapter
- Mini-Eval Programming Board
- 110 ~ 240V Power Supply, Euro-Plug Adapter
- iMAGEcraft C Compiler (Registration Required)
- ISSP Cable
- USB 2.0 Cable and Blue Cat-5 Cable
- 2 CY8C29466-24PXI 28-PDIP Chip Samples

Evaluation Tools

All evaluation tools are sold at the Cypress Online Store.

CY3210-MiniProg1

The CY3210-MiniProg1 kit enables the user to program PSoC devices via the MiniProg1 programming unit. The MiniProg1 is a small, compact prototyping programmer that connects to the PC via a provided USB 2.0 cable. The kit includes:

- MiniProg Programming Unit
- MiniEval Socket Programming and Evaluation Board
- 28-Pin CY8C29466-24PXI PDIP PSoC Device Sample
- 28-Pin CY8C27443-24PXI PDIP PSoC Device Sample
- PSoC Designer Software CD
- Getting Started Guide
- USB 2.0 Cable

CY3210-PSoCEval1

The CY3210-PSoCEval1 kit features an evaluation board and the MiniProg1 programming unit. The evaluation board includes an LCD module, potentiometer, LEDs, and plenty of bread-boarding space to meet all of your evaluation needs. The kit includes:

- Evaluation Board with LCD Module
- MiniProg Programming Unit
- 28-Pin CY8C29466-24PXI PDIP PSoC Device Sample (2)
- PSoC Designer Software CD
- Getting Started Guide
- USB 2.0 Cable

CY3214-PSoCEvalUSB

The CY3214-PSoCEvalUSB evaluation kit features a development board for the CY8C24794-24LFXI PSoC device. Special features of the board include both USB and capacitive sensing development and debugging support. This evaluation board also includes an LCD module, potentiometer, LEDs, an enunciator and plenty of bread boarding space to meet all of your evaluation needs. The kit includes:

- PSoCEvalUSB Board
- LCD Module
- MiniProg Programming Unit
- Mini USB Cable
- PSoC Designer and Example Projects CD
- Getting Started Guide
- Wire Pack

Device Programmers

All device programmers are purchased from the Cypress Online Store.

CY3216 Modular Programmer

The CY3216 Modular Programmer kit features a modular programmer and the MiniProg1 programming unit. The modular programmer includes three programming module cards and supports multiple Cypress products. The kit includes:

- Modular Programmer Base
- Three Programming Module Cards
- MiniProg Programming Unit
- PSoC Designer Software CD
- Getting Started Guide
- USB 2.0 Cable

CY3207ISSP In-System Serial Programmer (ISSP)

The CY3207ISSP is a production programmer. It includes protection circuitry and an industrial case that is more robust than the MiniProg in a production programming environment.

Note that CY3207ISSP needs special software and is not compatible with PSoC Programmer. The kit includes:

- CY3207 Programmer Unit
- PSoC ISSP Software CD
- 110 ~ 240V Power Supply, Euro-Plug Adapter
- USB 2.0 Cable

Accessories (Emulation and Programming)

Table 38. Emulation and Programming Accessories

Part Number	Pin Package	Flex-Pod Kit ^[15]	Foot Kit ^[16]	Adapter ^[17]
CY8C20236-24LKXI	16 QFN	CY3250-20266QFN	CY3250-16QFN-RK	See note 15
CY8C20246-24LKXI	16 QFN	CY3250-20266QFN	CY3250-16QFN-FK	See note 17
CY8C20336-24LQXI	24 QFN	CY3250-20366QFN	CY3250-24QFN-FK	See note 15
CY8C20346-24LQXI	24 QFN	CY3250-20366QFN	CY3250-24QFN-FK	See note 17
CY8C20396-24LQXI	24 QFN	Not Available		
CY8C20436-24LQXI	32 QFN	CY3250-20466QFN	CY3250-32QFN-RK	See note 15
CY8C20446-24LQXI	32 QFN	CY3250-20466QFN	CY3250-32QFN-FK	See note 17
CY8C20466-24LQXI	32 QFN	CY3250-20466QFN	CY3250-32QFN-FK	See note 17
CY8C20496-24LQXI	32 QFN	Not Available		
CY8C20536-24PVXI	48 SSOP	CY3250-20X66	CY3250-48SSOP-FK	See note 17
CY8C20546-24PVXI	48 SSOP	CY3250-20X66	CY3250-48SSOP-FK	See note 17
CY8C20566-24PVXI	48 SSOP	CY3250-20X66	CY3250-48SSOP-FK	See note 17
CY8C20636-24LTXI	48 QFN	CY3250-20666QFN	CY3250-48QFN-FK	See note 17
CY8C20646-24LTXI	48 QFN	CY3250-20666QFN	CY3250-48QFN-FK	See note 17
CY8C20666-24LTXI	48 QFN	CY3250-20666QFN	CY3250-48QFN-FK	See note 17

Third-Party Tools

Several tools have been specially designed by the following third-party vendors to accompany PSoC devices during development and production. Specific details for each of these tools can be found at <http://www.cypress.com> under Documentation > Evaluation Boards.

Build a PSoC Emulator into Your Board

For details on how to emulate your circuit before going to volume production using an on-chip debug (OCD) non-production PSoC device, refer Application Note “Debugging - Build a PSoC Emulator into Your Board - AN2323” at <http://www.cypress.com/?rID2748>.

Notes

15. Flex-Pod kit includes a practice flex-pod and a practice PCB, in addition to two flex-pods.

16. Foot kit includes surface mount feet that can be soldered to the target PCB.

17. Programming adapter converts non-DIP package to DIP footprint. Specific details and ordering information for each of the adapters can be found at <http://www.emulation.com>.

Ordering Information

The following table lists the CY8C20x36/46/66/96 PSoC devices' key package features and ordering codes.

Table 39. PSoC Device Key Features and Ordering Information

Package	Ordering Code	Flash (Bytes)	SRAM (Bytes)	CapSense Blocks	Digital I/O Pins	Analog Inputs ^[18]	XRES Pin	USB
16-Pin (3x3x0.6mm) QFN	CY8C20236-24LKXI	8K	1K	1	13	13	Yes	No
16-Pin (3x3x0.6mm) QFN (Tape and Reel)	CY8C20236-24LKXIT	8K	1K	1	13	13	Yes	No
16 Pin (3x3 x 0.6 mm) QFN	CY8C20246-24LKXI	16K	2K	1	13	13	Yes	No
16 Pin (3x3 x 0.6 mm) QFN (Tape and Reel)	CY8C20246-24LKXIT	16K	2K	1	13	13	Yes	No
24-Pin (4x4x0.6mm) QFN	CY8C20336-24LQXI	8K	1K	1	20	20	Yes	No
24-Pin (4x4x0.6mm) QFN (Tape and Reel)	CY8C20336-24LQXIT	8K	1K	1	20	20	Yes	No
24 Pin (4x4 x 0.6 mm) QFN	CY8C20346-24LQXI	16K	2K	1	20	20	Yes	No
24 Pin (4x4 x 0.6 mm) QFN (Tape and Reel)	CY8C20346-24LQXIT	16K	2K	1	20	20	Yes	No
24-Pin (4x4x0.6mm) QFN	CY8C20396-24LQXI	16K	2K	1	19	19	Yes	Yes
24-Pin (4x4x0.6mm) QFN (Tape and Reel)	CY8C20396-24LQXIT	16K	2K	1	19	19	Yes	Yes
32-Pin (5x5x0.6mm) QFN	CY8C20436-24LQXI	8K	1K	1	28	28	Yes	No
32-Pin (5x5x0.6mm) QFN (Tape and Reel)	CY8C20436-24LQXIT	8K	1K	1	28	28	Yes	No
32 Pin (5x5 x 0.6 mm) QFN	CY8C20446-24LQXI	16K	2K	1	28	28	Yes	No
32 Pin (5x5 x 0.6 mm) QFN (Tape and Reel)	CY8C20446-24LQXIT	16K	2K	1	28	28	Yes	No
32 Pin (5x5 x 0.6 mm) QFN	CY8C20466-24LQXI	32K	2K	1	28	28	Yes	No
32 Pin (5x5 x 0.6 mm) QFN (Tape and Reel)	CY8C20466-24LQXIT	32K	2K	1	28	28	Yes	No
32 Pin (5x5 x 0.6 mm) QFN	CY8C20496-24LQXI	16K	2K	1	25	25	Yes	No
32 Pin (5x5 x 0.6 mm) QFN (Tape and Reel)	CY8C20496-24LQXIT	16K	2K	1	25	25	Yes	No
48-Pin SSOP	CY8C20536-24PVXI	8K	1K	1	36	36	Yes	No
48-Pin SSOP (Tape and Reel)	CY8C20536-24PVXIT	8K	1K	1	36	36	Yes	No
48-Pin SSOP	CY8C20546-24PVXI	16K	2K	1	36	36	Yes	No
48-Pin SSOP (Tape and Reel)	CY8C20546-24PVXIT	16K	2K	1	36	36	Yes	No
48-Pin SSOP	CY8C20566-24PVXI	32K	2K	1	36	36	Yes	No
48-Pin SSOP (Tape and Reel)	CY8C20566-24PVXIT	32K	2K	1	36	36	Yes	No
48 Pin (7x7 mm) QFN	CY8C20636-24LTXI	8K	1K	1	36	36	Yes	No
48 Pin (7x7 mm) QFN (Tape and Reel)	CY8C20636-24LTXIT	8K	1K	1	36	36	Yes	No
48 Pin (7x7 mm) QFN	CY8C20646-24LTXI	16K	2K	1	36	36	Yes	Yes
48 Pin (7x7 mm) QFN (Tape and Reel)	CY8C20646-24LTXIT	16K	2K	1	36	36	Yes	Yes
48 Pin (7x7 mm) QFN	CY8C20666-24LTXI	32K	2K	1	36	36	Yes	Yes
48 Pin (7x7 mm) QFN (Tape and Reel)	CY8C20666-24LTXIT	32K	2K	1	36	36	Yes	Yes
48 Pin (7x7 mm) QFN (OCD) ^[4]	CY8C20066-24LTXI	32K	2K	1	36	36	Yes	Yes

Notes

18. Dual-function Digital I/O Pins also connect to the common analog mux.

Document History Page

Document Title: CY8C20x36/46/66/96 CapSense® Applications Document Number: 001-12696				
Revision	ECN	Origin of Change	Submission Date	Description of Change
**	766857	HMT	See ECN	New silicon and document (Revision **).
*A	1242866	HMT	See ECN	Add features. Update all applicable sections. Update specs. Fix 24-pin QFN pinout moving pins inside. Update package revisions. Update and add to Emulation and Programming Accessories table.
*B	2174006	AESA	See ECN	Added 48-Pin SSOP Part Pinout Modified symbol R _{VDD} to R _{GND} in Table DC Analog Mux Bus Specification Added footnote in Table DC Analog Mux Bus Specification Added 16K FLASH Parts. Updated Notes, Package Diagrams and Ordering Information table. Updated Thermal Impedance and Solder Reflow tables
*C	2587518	TOF/JASM/MNU/ HMT	10/13/08	Converted from Preliminary to Final Fixed broken links. Updated data sheet template. Added operating voltage ranges with USB ADC resolution changed from 10-bit to 8-bit Included ADC specifications table Included Comparator specification table Included Voh7, Voh8, Voh9, Voh10 specs Flash data retention – condition added to Note Input leakage spec changed to 1 μA max GPIO rise time for ports 0,1 and ports 2,3 made common AC Programming specifications updated Included AC Programming cycle timing diagram AC SPI specification updated The VIH for 3.0<Vdd<2.4 changed to 1.6 from 2.0 Added USB specification Added SPI CLK to P1[0] Updated package diagrams Updated thermal impedances for QFN packages Updated F _{GPIO} parameter in Table 23 Updated voltage ranges for F _{SPIM} and F _{SPIS} in Table 30 Update Development Tools, add Designing with PSoC Designer. Edit, fix links, notes and table format. Update R _{IN} formula, fix TRise parameter names in GPIO figure, fix Switch Rate note. Update maximum data in Table 20. DC POR and LVD Specifications.
*D	2649637	SNV/AESA	03/17/2009	Changed title to “CY8C20x36/46/66, CY8C20396 CapSense™ Applications”. Updated data sheet Features, pin information, and ordering information sections. Updated package diagram 001-42168 to *C.
*E	2700196	SNV/PYRS	04/30/2009	Added part numbers CY8C20496, CY8C20536, CY8C20546, CY8C20636, CY8C20646 Updated Features on page 1 Added 48-Pin QFN without USB pin Diagram and Pin Definition table Added 32-Pin QFN (with USB) package Added SPI Master and Slave AC Specifications Updated Emulations and Programming Accessories Table on page 33 Updated Ordering Information on page 37 Removed reference to Hi-Tech C Compiler in Development Tool Selection on page 35

Sales, Solutions, and Legal Information

Worldwide Sales and Design Support

Cypress maintains a worldwide network of offices, solution centers, manufacturer's representatives, and distributors. To find the office closest to you, visit us at cypress.com/sales.

Products

PSoC	psoc.cypress.com
Clocks & Buffers	clocks.cypress.com
Wireless	wireless.cypress.com
Memories	memory.cypress.com
Image Sensors	image.cypress.com

PSoC Solutions

General	psoc.cypress.com/solutions
Low Power/Low Voltage	psoc.cypress.com/low-power
Precision Analog	psoc.cypress.com/precision-analog
LCD Drive	psoc.cypress.com/lcd-drive
CAN 2.0b	psoc.cypress.com/can
USB	psoc.cypress.com/usb

© Cypress Semiconductor Corporation, 2007-2009. The information contained herein is subject to change without notice. Cypress Semiconductor Corporation assumes no responsibility for the use of any circuitry other than circuitry embodied in a Cypress product. Nor does it convey or imply any license under patent or other rights. Cypress products are not warranted nor intended to be used for medical, life support, life saving, critical control or safety applications, unless pursuant to an express written agreement with Cypress. Furthermore, Cypress does not authorize its products for use as critical components in life-support systems where a malfunction or failure may reasonably be expected to result in significant injury to the user. The inclusion of Cypress products in life-support systems application implies that the manufacturer assumes all risk of such use and in doing so indemnifies Cypress against all charges.



Any Source Code (software and/or firmware) is owned by Cypress Semiconductor Corporation (Cypress) and is protected by and subject to worldwide patent protection (United States and foreign), United States copyright laws and international treaty provisions. Cypress hereby grants to licensee a personal, non-exclusive, non-transferable license to copy, use, modify, create derivative works of, and compile the Cypress Source Code and derivative works for the sole purpose of creating custom software and/or firmware in support of licensee product to be used only in conjunction with a Cypress integrated circuit as specified in the applicable agreement. Any reproduction, modification, translation, compilation, or representation of this Source Code except as specified above is prohibited without the express written permission of Cypress.

Disclaimer: CYPRESS MAKES NO WARRANTY OF ANY KIND, EXPRESS OR IMPLIED, WITH REGARD TO THIS MATERIAL, INCLUDING, BUT NOT LIMITED TO, THE IMPLIED WARRANTIES OF MERCHANTABILITY AND FITNESS FOR A PARTICULAR PURPOSE. Cypress reserves the right to make changes without further notice to the materials described herein. Cypress does not assume any liability arising out of the application or use of any product or circuit described herein. Cypress does not authorize its products for use as critical components in life-support systems where a malfunction or failure may reasonably be expected to result in significant injury to the user. The inclusion of Cypress' product in a life-support systems application implies that the manufacturer assumes all risk of such use and in doing so indemnifies Cypress against all charges.

Use may be limited by and subject to the applicable Cypress software license agreement.

Looking for pricing, stock, or lifecycle information?

Click below to explore more details on WIN SOURCE:

-  [View CY8C20666-24LTXI on WIN SOURCE](#)
-  [Cypress Semiconductor Corp Information](#)

Optimize Your Supply Chain with WIN SOURCE Solutions

-  Global Sourcing Solution
-  Obsolete Management
-  Cost Control Management
-  Shortage Management
-  Alternative Solution
-  Excess Inventory Management