



**THE DATASHEET OF
LMK03200ISQE/NOPB**



LMK03200 Family Precision 0-Delay Clock Conditioner with Integrated VCO

Check for Samples: [LMK03200](#)

1 Introduction

1.1 Features

- Integrated VCO with Very Low Phase Noise Floor
- Integrated Integer-N PLL with Outstanding Normalized Phase Noise Contribution of -224 dBc/Hz
- VCO Divider Values of 2 to 8 (All Divides)
 - Bypassable with VCO Mux When Not in 0-delay Mode
- Channel Divider Values of 1, 2 to 510 (Even Divides)
- LVDS and LVPECL Clock Outputs
- Partially Integrated Loop Filter
- Dedicated Divider and Delay Blocks on Each Clock Output
- 0-delay Outputs
- Internal or External Feedback of Output Clock
- Delay Blocks on N and R Phase Detector Inputs for Lead/Lag Global Skew Adjust
- Pin Compatible Family of Clocking Devices
- 3.15 to 3.45 V Operation
- Package: 48 Pin WQFN (7.0 x 7.0 x 0.8 mm)
- 200 fs RMS Clock Generator Performance (10 Hz to 20 MHz) with a clean input clock

1.2 Target Applications

- Data Converter Clocking
- Networking, SONET/SDH, DSLAM
- Wireless Infrastructure
- Medical
- Test and Measurement
- Military / Aerospace

Device	Outputs	VCO	
		Tuning Range (MHz)	RMS Jitter (fs)
LMK03200	3 LVDS 5 LVPECL	1185 - 1296	800

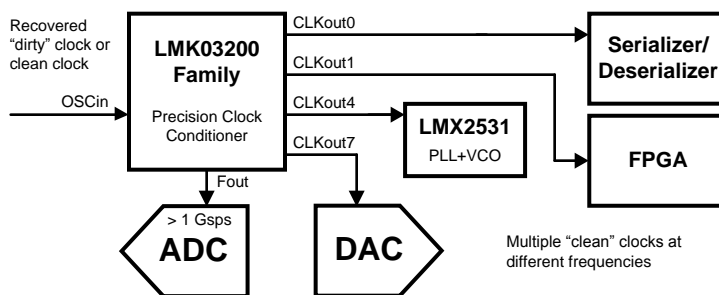

1.3 Description

The LMK03200 family of precision clock conditioners combine the functions of jitter cleaning/reconditioning, multiplication, and 0-delay distribution of a reference clock. The devices integrate a Voltage Controlled Oscillator (VCO), a high performance Integer-N Phase Locked Loop (PLL), a partially integrated loop filter, and up to eight outputs in various LVDS and LVPECL combinations.

The VCO output is optionally accessible on the Fout port. Internally, the VCO output goes through a VCO divider to feed the various clock distribution blocks.



Please be aware that an important notice concerning availability, standard warranty, and use in critical applications of Texas Instruments semiconductor products and disclaimers thereto appears at the end of this data sheet.

All trademarks are the property of their respective owners.

Each clock distribution block includes a programmable divider, a phase synchronization circuit, a programmable delay, a clock output mux, and an LVDS or LVPECL output buffer. The PLL also features delay blocks to permit global phase adjustment of clock output phase. This allows multiple integer-related and phase-adjusted copies of the reference to be distributed to eight system components.

The clock conditioners come in a 48-pin WQFN package and are footprint compatible with other clocking devices in the same family.

1	Introduction	1			
1.1	Features	1			
1.2	Target Applications	1			
1.3	Description	1			
2	Device Information	3			
2.1	Functional Block Diagram	3			
2.2	Connection Diagram	3			
3	Electrical Specifications	5			
3.1	Absolute Maximum Ratings	5			
3.2	Recommended Operating Conditions	5			
3.3	Package Thermal Resistance	5			
3.4	Electrical Characteristics	6			
3.5	Serial Data Timing Diagram	10			
3.6	Charge Pump Current Specification Definitions	11			
4	Typical Performance Characteristics	12			
5	Functional Description	14			
5.1	BIAS PIN	14			
5.2	LDO BYPASS	14			
5.3	OSCILLATOR INPUT PORT (OSCin, OSCin*)	14			
5.4	LOW NOISE, FULLY INTEGRATED VCO	14			
5.5	LVDS/LVPECL OUTPUTS	15			
5.6	GLOBAL CLOCK OUTPUT SYNCHRONIZATION	15			
5.7	CLKout OUTPUT STATES	16			
5.8	GLOBAL OUTPUT ENABLE AND LOCK DETECT	16			
5.9	POWER ON RESET	16			
5.10	DIGITAL LOCK DETECT	17			
5.11	CLKout DELAYS	17			
5.12	GLOBAL DELAYS	17			
5.13	VCO DIVIDER BYPASS MODE	18			
5.14	0-DELAY MODE	18			
6	General Programming Information	19			
6.1	Recommended Programming Sequence, without 0-Delay Mode	19			
6.2	Recommended Programming Sequence, with 0-Delay Mode	19			
6.3	Recommended Programming Sequence, bypassing VCO divider	23			
6.4	Register R0 to R7	28			
6.5	Register R8	32			
6.6	Register R9	32			
6.7	Register R11	32			
6.8	Register R13	33			
6.9	Register R14	34			
6.10	REGISTER R15	37			
7	Application Information	39			
7.1	SYSTEM LEVEL DIAGRAM	39			
7.2	BIAS PIN	39			
7.3	LDO BYPASS	39			
7.4	LOOP FILTER	40			
7.5	CURRENT CONSUMPTION / POWER DISSIPATION CALCULATIONS	41			
7.6	THERMAL MANAGEMENT	42			
7.7	TERMINATION AND USE OF CLOCK OUTPUTS (DRIVERS)	43			
7.8	OSCin INPUT	46			
7.9	MORE THAN EIGHT OUTPUTS WITH AN LMK03200 FAMILY DEVICE	47			
7.10	DIFFERENTIAL VOLTAGE MEASUREMENT TERMINOLOGY	47			
	Revision History	48			

2 Device Information

2.1 Functional Block Diagram

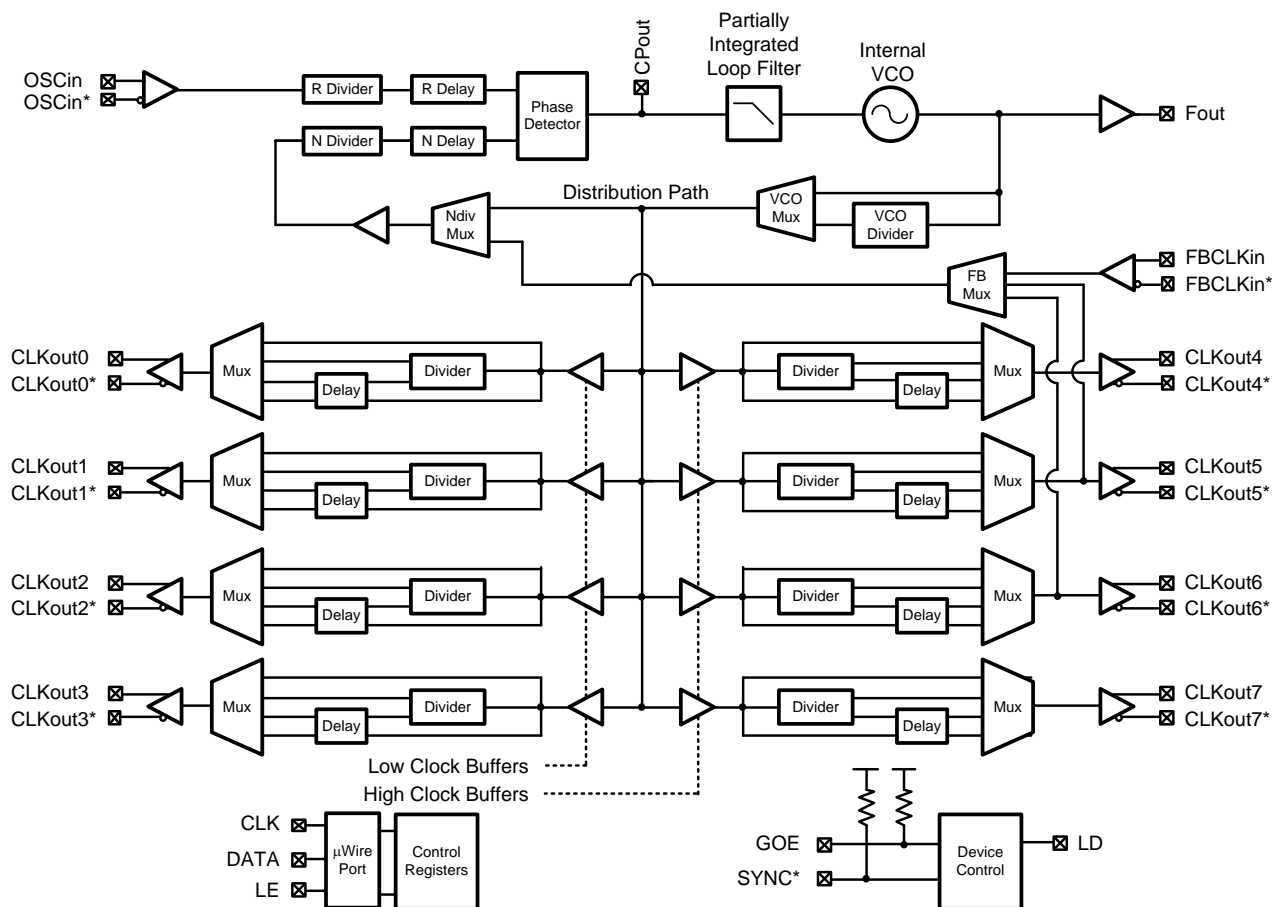

2.2 Connection Diagram

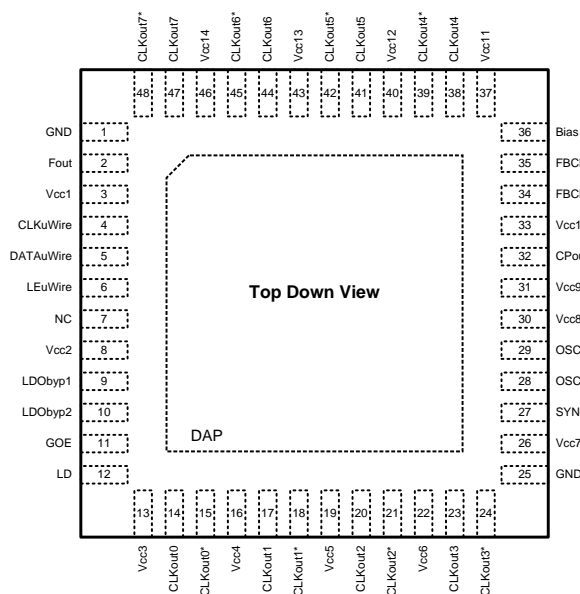

Figure 2-1. 48-Pin WQFN Package

Table 2-1. PIN DESCRIPTIONS

Pin #	Pin Name	I/O	Description
1, 25	GND	-	Ground
2	Fout	O	Internal VCO Frequency Output
3, 8, 13, 16, 19, 22, 26, 30, 31, 33, 37, 40, 43, 46	Vcc1, Vcc2, Vcc3, Vcc4, Vcc5, Vcc6, Vcc7, Vcc8, Vcc9, Vcc10, Vcc11, Vcc12, Vcc13, Vcc14	-	Power Supply
4	CLKuWire	I	MICROWIRE Clock Input
5	DATAuWire	I	MICROWIRE Data Input
6	LEuWire	I	MICROWIRE Latch Enable Input
7	NC	-	No Connection to these pins
9, 10	LDObyp1, LDObyp2	-	LDO Bypass
11	GOE	I	Global Output Enable
12	LD	O	Lock Detect and Test Output
14, 15	CLKout0, CLKout0*	O	LVDS Clock Output 0
17, 18	CLKout1, CLKout1*	O	LVDS Clock Output 1
20, 21	CLKout2, CLKout2*	O	LVDS Clock Output 2
23, 24	CLKout3, CLKout3*	O	LVPECL Clock Output 3
27	SYNC*	I	Global Clock Output Synchronization
28, 29	OScin, OSCin*	I	Oscillator Clock Input; Should be AC coupled
32	CPout	O	Charge Pump Output
34, 35	FBCLKin, FBCLKin*	I	External Feedback Clock Input for 0-delay mode
36	Bias	I	Bias Bypass
38, 39	CLKout4, CLKout4*	O	LVPECL Clock Output 4
41, 42	CLKout5, CLKout5*	O	LVPECL Clock Output 5
44, 45	CLKout6, CLKout6*	O	LVPECL Clock Output 6
47, 48	CLKout7, CLKout7*	O	LVPECL Clock Output 7
DAP	DAP	-	Die Attach Pad is Ground



These devices have limited built-in ESD protection. The leads should be shorted together or the device placed in conductive foam during storage or handling to prevent electrostatic damage to the MOS gates.

3 Electrical Specifications

3.1 Absolute Maximum Ratings⁽¹⁾⁽²⁾⁽³⁾

Parameter	Symbol	Ratings	Units
Power Supply Voltage	V_{CC}	-0.3 to 3.6	V
Input Voltage	V_{IN}	-0.3 to ($V_{CC} + 0.3$)	V
Storage Temperature Range	T_{STG}	-65 to 150	°C
Lead Temperature (solder 4 s)	T_L	+260	°C
Junction Temperature	T_J	125	°C

- (1) "Absolute Maximum Ratings" indicate limits beyond which damage to the device may occur, including inoperability and degradation of device reliability and/or performance. Functional operation of the device and/or non-degradation at the Absolute Maximum Ratings or other conditions beyond those indicated in the Recommended Operating Conditions is not implied. The Recommended Operating Conditions indicate conditions at which the device is functional and the device should not be operated beyond such conditions.
- (2) This device is a high performance integrated circuit with ESD handling precautions. Handling of this device should only be done at ESD protected work stations. The device is rated to a HBM-ESD of > 2 kV, a MM-ESD of > 200 V, and a CDM-ESD of > 1.2 kV.
- (3) If Military/Aerospace specified devices are required, please contact the Texas Instruments Sales Office/Distributors for availability and specifications.

3.2 Recommended Operating Conditions

Parameter	Symbol	Min	Typ	Max	Units
Ambient Temperature	T_A	-40	25	85	°C
Power Supply Voltage	V_{CC}	3.15	3.3	3.45	V

3.3 Package Thermal Resistance

Package	θ_{JA}	θ_{J-PAD} (Thermal Pad)
48-Lead WQFN ⁽¹⁾	27.4° C/W	5.8° C/W

- (1) Specification assumes 16 thermal vias connect the die attach pad to the embedded copper plane on the 4-layer JEDEC board. These vias play a key role in improving the thermal performance of the WQFN. It is recommended that the maximum number of vias be used in the board layout.

3.4 Electrical Characteristics ⁽¹⁾

(3.15 V ≤ V_{CC} ≤ 3.45 V, -40 °C ≤ T_A ≤ 85 °C, Differential Inputs/Outputs; V_{boost}=0; except as specified. Typical values represent most likely parametric norms at V_{CC} = 3.3 V, T_A = 25 °C, and at the Recommended Operation Conditions at the time of product characterization and are not guaranteed).

Symbol	Parameter	Conditions	Min	Typ	Max	Units
Current Consumption						
I _{CC}	Power Supply Current ⁽²⁾	Entire device; one LVDS and one LVPECL clock enabled; no divide; no delay.		161.8		mA
		Entire device; All Outputs Off (no emitter resistors placed)		86		
I _{CC} PD	Power Down Current	POWERDOWN = 1		5		mA
Reference Oscillator Input						
f _{OSCin}	Reference Oscillator Input Frequency Range		1		200	MHz
V _{ID} OSCin	Reference Oscillator Differential Input Voltage ⁽³⁾ ⁽⁴⁾	AC coupled	0.2		1.6	V
V _{OSCin}	Reference Oscillator Single-ended Input Voltage ⁽⁴⁾	AC coupled; Unused pin AC coupled to GND	0.2		2.0	V _{pp}
SLEW _{OSCin}	Reference Oscillator Input Slew Rate ⁽⁴⁾	20% to 80%; For each input pin	0.15	0.5		V/ns
External Feedback Clock Input						
f _{FBCLKin}	External Feedback Clock Input Frequency Range		1		800	MHz
V _{ID} FBCLKin	External Feedback Clock Differential Input Voltage ⁽³⁾ ⁽⁴⁾	AC coupled	0.2		1.6	V
V _{FBCLKin}	External Feedback Clock Single-ended Input Voltage ⁽⁴⁾	AC coupled; Unused pin AC coupled to GND	0.2		2.0	V _{pp}
SLEW _{FBCLKin}	External Feedback Clock Input Slew Rate ⁽⁴⁾	20% to 80%; For each input pin	0.15	0.5		V/ns

- (1) The Electrical Characteristics table lists ensured specifications under the listed Recommended Operating Conditions except as otherwise modified or specified by the Electrical Characteristics Conditions and/or Notes. Typical specifications are estimations only and are not ensured.
- (2) See Section [Section 7.5](#) for more information.
- (3) See Section [Section 7.10](#) for more information.
- (4) Specification is ensured by characterization and is not tested in production.

Electrical Characteristics ⁽¹⁾ (continued)

(3.15 V ≤ V_{CC} ≤ 3.45 V, -40 °C ≤ T_A ≤ 85 °C, Differential Inputs/Outputs; V_{boost}=0; except as specified. Typical values represent most likely parametric norms at V_{CC} = 3.3 V, T_A = 25 °C, and at the Recommended Operation Conditions at the time of product characterization and are not guaranteed).

Symbol	Parameter	Conditions	Min	Typ	Max	Units
PLL						
f _{PD}	Phase Detector Frequency				40	MHz
I _{SRCE} CPout	Charge Pump Source Current	V _{CPout} = V _{CC} /2, PLL_CP_GAIN = 1x		100		μA
		V _{CPout} = V _{CC} /2, PLL_CP_GAIN = 4x		400		
		V _{CPout} = V _{CC} /2, PLL_CP_GAIN = 16x		1600		
		V _{CPout} = V _{CC} /2, PLL_CP_GAIN = 32x		3200		
I _{SINK} CPout	Charge Pump Sink Current	V _{CPout} = V _{CC} /2, PLL_CP_GAIN = 1x		-100		μA
		V _{CPout} = V _{CC} /2, PLL_CP_GAIN = 4x		-400		
		V _{CPout} = V _{CC} /2, PLL_CP_GAIN = 16x		-1600		
		V _{CPout} = V _{CC} /2, PLL_CP_GAIN = 32x		-3200		
I _{CPout} TRI	Charge Pump TRI-STATE Current	0.5 V < V _{CPout} < V _{CC} - 0.5 V		2	10	nA
I _{CPout} %MIS	Magnitude of Charge Pump Sink vs. Source Current Mismatch	V _{CPout} = V _{CC} / 2 T _A = 25°C		3		%
I _{CPout} VTUNE	Magnitude of Charge Pump Current vs. Charge Pump Voltage Variation	0.5 V < V _{CPout} < V _{CC} - 0.5 V T _A = 25°C		4		%
I _{CPout} TEMP	Magnitude of Charge Pump Current vs. Temperature Variation			4		%
PN10kHz	PLL 1/f Noise at 10 kHz Offset ⁽¹⁾ Normalized to 1 GHz Output Frequency	PLL_CP_GAIN = 1x		-117		dBc/Hz
		PLL_CP_GAIN = 32x		-122		
PN1Hz	Normalized Phase Noise Contribution ⁽²⁾	PLL_CP_GAIN = 1x		-219		dBc/Hz
		PLL_CP_GAIN = 32x		-224		

- (1) A specification in modeling PLL in-band phase noise is the 1/f flicker noise, L_{PLL_flicker}(f), which is dominant close to the carrier. Flicker noise has a 10 dB/decade slope. PN10kHz is normalized to a 10 kHz offset and a 1 GHz carrier frequency. PN10kHz = L_{PLL_flicker}(10 kHz) - 20log(Fout / 1 GHz), where L_{PLL_flicker}(f) is the single side band phase noise of only the flicker noise's contribution to total noise, L(f). To measure L_{PLL_flicker}(f) it is important to be on the 10 dB/decade slope close to the carrier. A high compare frequency and a clean crystal are important to isolating this noise source from the total phase noise, L(f). L_{PLL_flicker}(f) can be masked by the reference oscillator performance if a low power or noisy source is used. The total PLL in-band phase noise performance is the sum of L_{PLL_flicker}(f) and L_{PLL_flat}(f).
- (2) A specification in modeling PLL in-band phase noise is the Normalized Phase Noise Contribution, L_{PLL_flat}(f), of the PLL and is defined as PN1Hz = L_{PLL_flat}(f) - 20log(N) - 10log(f_{COMP}). L_{PLL_flat}(f) is the single side band phase noise measured at an offset frequency, f, in a 1 Hz Bandwidth and f_{COMP} is the phase detector frequency of the synthesizer. L_{PLL_flat}(f) contributes to the total noise, L(f). To measure L_{PLL_flat}(f) the offset frequency, f, must be chosen sufficiently smaller than the loop bandwidth of the PLL, and yet large enough to avoid a substantial noise contribution from the reference and flicker noise. L_{PLL_flat}(f) can be masked by the reference oscillator performance if a low power or noisy source is used.

Electrical Characteristics ⁽¹⁾ (continued)

(3.15 V ≤ V_{CC} ≤ 3.45 V, -40 °C ≤ T_A ≤ 85 °C, Differential Inputs/Outputs; V_{boost}=0; except as specified. Typical values represent most likely parametric norms at V_{CC} = 3.3 V, T_A = 25 °C, and at the Recommended Operation Conditions at the time of product characterization and are not guaranteed).

Symbol	Parameter	Conditions	Min	Typ	Max	Units
VCO						
f _{Fout}	VCO Tuning Range	LMK03200	1185		1296	MHz
ΔT _{CL}	Allowable Temperature Drift for Continuous Lock	After programming R15 for lock, only changes 0_DELAY_MODE and PLL_N for the purpose of enabling 0-delay mode permitted to ensure continuous lock. ⁽¹⁾			125	°C
P _{Fout}	Output Power to a 50 Ω load driven by Fout ⁽²⁾	LMK03200; T _A = 25 °C		3.3		dBm
K _{VCO}	Fine Tuning Sensitivity ⁽³⁾	LMK03200		7 to 9		MHz/V
J _{RMSFout}	Fout RMS Period Jitter (12 kHz to 20 MHz bandwidth)	LMK03200		800		fs
Clock Skew and Delay						
t _{SKEWLVDS}	CLKoutX to CLKoutY ⁽⁴⁾	Equal loading and identical clock configuration R _L = 100 Ω	-30	±4	30	ps
t _{SKEWLVPECL}	CLKoutX to CLKoutY ⁽⁴⁾	Equal loading and identical clock configuration R _L = 100 Ω	-30	±3	30	ps
td _{0-DELAY}	OSCin to CLKoutX delay ⁽⁴⁾	0-Delay mode active; PLL_N_DLY = 0; PLL_R_DLY = 0; FB_MUX = 0 (CLKout5)	-300	-65	300	ps
		0-Delay mode active; PLL_N_DLY = 0; PLL_R_DLY = 0; FB_MUX = 2 (CLKout6)	-300	35	300	
		0-Delay mode active; PLL_N_DLY = 0; PLL_R_DLY = 0; FB_MUX = 1 (FBCLKin)	-700	-400	-100	
		0-Delay mode active; PLL_N_DLY = 0; PLL_R_DLY = 3; FB_MUX = 1 (FBCLKin)	-400	35	400	

- (1) Allowable Temperature Drift for Continuous Lock is how far the temperature can drift in either direction and stay in lock from the ambient temperature and programmed state at which the device was when the frequency calibration routine was run. The action of programming the R15 register, even to the same value, when 0_DELAY_MODE = 0 activates a frequency calibration routine. This implies that the device will work over the entire frequency range, but if the temperature drifts more than the maximum allowable drift for continuous lock, then it will be necessary to reprogram the R15 register while 0_DELAY_MODE = 0 to ensure that the device stays in lock. Regardless of what temperature the device was initially programmed at, the ambient temperature can never drift outside the range of -40 °C ≤ T_A ≤ 85 °C without violating specifications. For this specification to be valid, the programmed state of the device must not change after R15 is programmed except for 0_DELAY_MODE and PLL_N for the purpose of enabling 0-delay mode.
- (2) Output power varies as a function of frequency. When a range is shown, the higher output power applies to the lower frequency and the lower output power applies to the higher frequency.
- (3) The lower sensitivity indicates the typical sensitivity at the lower end of the tuning range, the higher sensitivity at the higher end of the tuning range.
- (4) Specification is ensured by characterization and is not tested in production.

Electrical Characteristics ⁽¹⁾ (continued)

(3.15 V ≤ V_{CC} ≤ 3.45 V, -40 °C ≤ T_A ≤ 85 °C, Differential Inputs/Outputs; V_{boost}=0; except as specified. Typical values represent most likely parametric norms at V_{CC} = 3.3 V, T_A = 25 °C, and at the Recommended Operation Conditions at the time of product characterization and are not guaranteed).

Symbol	Parameter	Conditions	Min	Typ	Max	Units
Clock Distribution Section - LVDS Clock Outputs ⁽¹⁾						
Jitter _{ADD}	Additive RMS Jitter ⁽¹⁾	R _L = 100 Ω Distribution Path = 765 MHz Bandwidth = 12 kHz to 20 MHz	CLKoutX_MUX = Bypass (no divide or delay)		20	fs
			CLKoutX_MUX = Divided (no delay) CLKoutX_DIV = 4		75	
V _{OD}	Differential Output Voltage	R _L = 100 Ω	250	350	450	mV
ΔV _{OD}	Change in magnitude of V _{OD} for complementary output states	R _L = 100 Ω	-50		50	mV
V _{OS}	Output Offset Voltage	R _L = 100 Ω	1.070	1.25	1.370	V
ΔV _{OS}	Change in magnitude of V _{OS} for complementary output states	R _L = 100 Ω	-35		35	mV
I _{SA} I _{SB}	Clock Output Short Circuit Current single-ended	Single-ended outputs shorted to GND	-24		24	mA
I _{SAB}	Clock Output Short Circuit Current differential	Complementary outputs tied together	-12		12	mA
Clock Distribution Section ⁽¹⁾ - LVPECL Clock Outputs						
Jitter _{ADD}	Additive RMS Jitter ⁽¹⁾	R _L = 100 Ω Distribution Path = 765 MHz Bandwidth = 12 kHz to 20 MHz	CLKoutX_MUX = Bypass (no divide or delay)		20	fs
			CLKoutX_MUX = Divided (no delay) CLKoutX_DIV = 4		75	
V _{OH}	Output High Voltage	Termination = 50 Ω to V _{CC} - 2 V		V _{CC} - 0.98		V
V _{OL}	Output Low Voltage			V _{CC} - 1.8		V
V _{OD}	Differential Output Voltage	R _L = 100 Ω	660	810	965	mV
Digital LVTTTL Interfaces ⁽²⁾						
V _{IH}	High-Level Input Voltage		2.0		V _{CC}	V
V _{IL}	Low-Level Input Voltage				0.8	V
I _{IH}	High-Level Input Current	V _{IH} = V _{CC}	-5.0		5.0	μA
I _{IL}	Low-Level Input Current	V _{IL} = 0	-40.0		5.0	μA
V _{OH}	High-Level Output Voltage	I _{OH} = +500 μA		V _{CC} - 0.4		V
V _{OL}	Low-Level Output Voltage	I _{OL} = -500 μA			0.4	V
Digital MICROWIRE Interfaces ⁽³⁾						
V _{IH}	High-Level Input Voltage		1.6		V _{CC}	V
V _{IL}	Low-Level Input Voltage				0.4	V
I _{IH}	High-Level Input Current	V _{IH} = V _{CC}	-5.0		5.0	μA
I _{IL}	Low-Level Input Current	V _{IL} = 0	-5.0		5.0	μA

(1) The Clock Distribution Section includes all parts of the device except the PLL and VCO sections. Typical Additive Jitter specifications apply to the clock distribution section only and this adds in an RMS fashion to the shaped jitter of the PLL and the VCO.

(2) Applies to GOE, LD, and SYNC*.

(3) Applies to CLKuWire, DATAuWire, and LEuWire.

Electrical Characteristics ⁽¹⁾ (continued)

(3.15 V ≤ V_{CC} ≤ 3.45 V, -40 °C ≤ T_A ≤ 85 °C, Differential Inputs/Outputs; V_{boost}=0; except as specified. Typical values represent most likely parametric norms at V_{CC} = 3.3 V, T_A = 25 °C, and at the Recommended Operation Conditions at the time of product characterization and are not guaranteed).

Symbol	Parameter	Conditions	Min	Typ	Max	Units
MICROWIRE Timing						
t _{CS}	Data to Clock Set Up Time	See Data Input Timing	25			ns
t _{CH}	Data to Clock Hold Time	See Data Input Timing	8			ns
t _{CWH}	Clock Pulse Width High	See Data Input Timing	25			ns
t _{CWL}	Clock Pulse Width Low	See Data Input Timing	25			ns
t _{ES}	Clock to Enable Set Up Time	See Data Input Timing	25			ns
t _{CES}	Enable to Clock Set Up Time	See Data Input Timing	25			ns
t _{EWH}	Enable Pulse Width High	See Data Input Timing	25			ns

3.5 Serial Data Timing Diagram

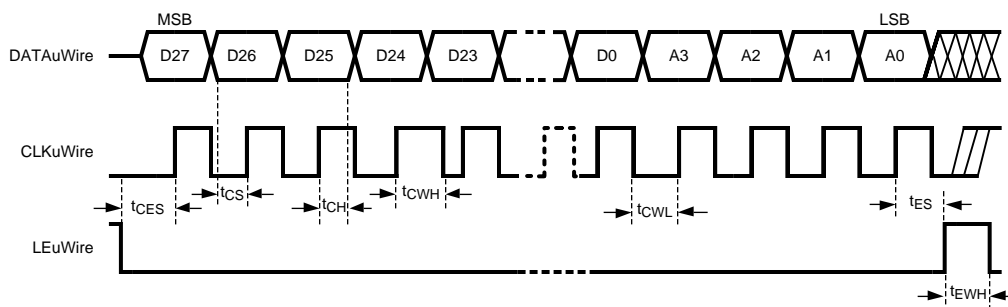

Data bits set on the DATAuWire signal are clocked into a shift register, MSB first, on each rising edge of the CLKuWire signal. On the rising edge of the LEuWire signal, the data is sent from the shift register to the addressed register determined by the LSB bits. After the programming is complete the CLKuWire, DATAuWire, and LEuWire signals should be returned to a low state. It is recommended that the slew rate of CLKuWire, DATAuWire, and LEuWire should be at least 30 V/μs.

3.6 Charge Pump Current Specification Definitions

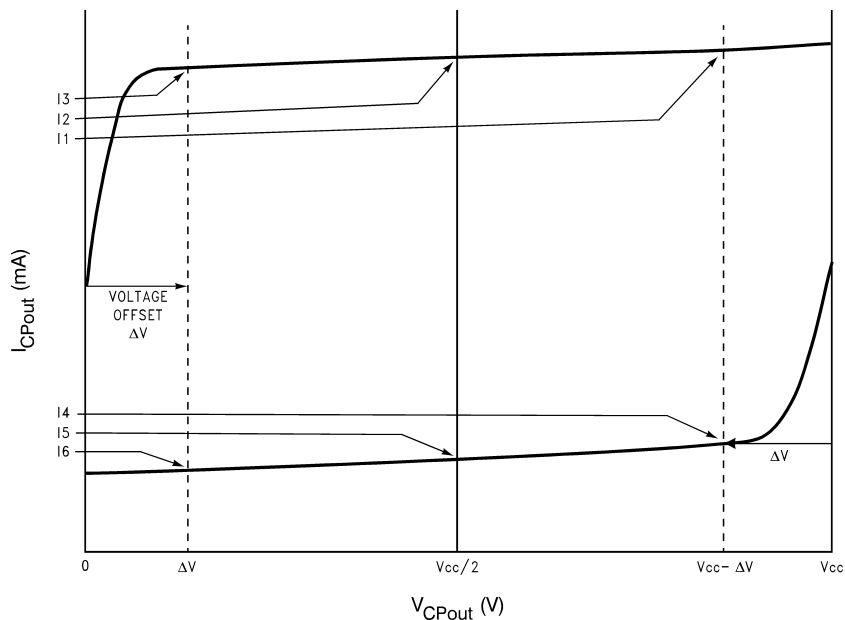

- I1 = Charge Pump Sink Current at $V_{CPout} = V_{CC} - \Delta V$
 - I2 = Charge Pump Sink Current at $V_{CPout} = V_{CC}/2$
 - I3 = Charge Pump Sink Current at $V_{CPout} = \Delta V$
 - I4 = Charge Pump Source Current at $V_{CPout} = V_{CC} - \Delta V$
 - I5 = Charge Pump Source Current at $V_{CPout} = V_{CC}/2$
 - I6 = Charge Pump Source Current at $V_{CPout} = \Delta V$
- ΔV = Voltage offset from the positive and negative supply rails. Defined to be 0.5 V for this device.

Charge Pump Output Current Magnitude Variation vs. Charge Pump Output Voltage

$$I_{CPout} \text{ Vs } V_{CPout} = \frac{|I1| - |I3|}{|I1| + |I3|} \times 100\%$$

$$= \frac{|I4| - |I6|}{|I4| + |I6|} \times 100\%$$

Charge Pump Sink Current vs. Charge Pump Output Source Current Mismatch

$$I_{CPout} \text{ Sink Vs } I_{CPout} \text{ Source} = \frac{|I2| - |I5|}{|I2| + |I5|} \times 100\%$$

Charge Pump Output Current Magnitude Variation vs. Temperature

$$I_{CPout} \text{ Vs } T_A = \frac{|I2|_{T_A} - |I2|_{T_A=25^\circ C}}{|I2|_{T_A=25^\circ C}} \times 100\%$$

$$= \frac{|I5|_{T_A} - |I5|_{T_A=25^\circ C}}{|I5|_{T_A=25^\circ C}} \times 100\%$$

4 Typical Performance Characteristics

NOTE

These plots show performance at frequencies beyond what the part is ensured to operate at to give the user an idea of the capabilities of the part, but they do not imply any sort of ensured specification.

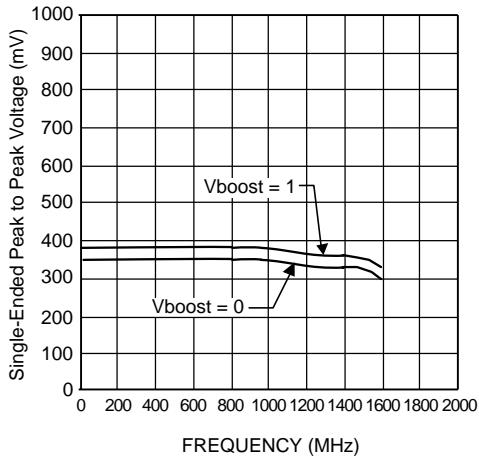

Figure 4-1. LVDS Vod

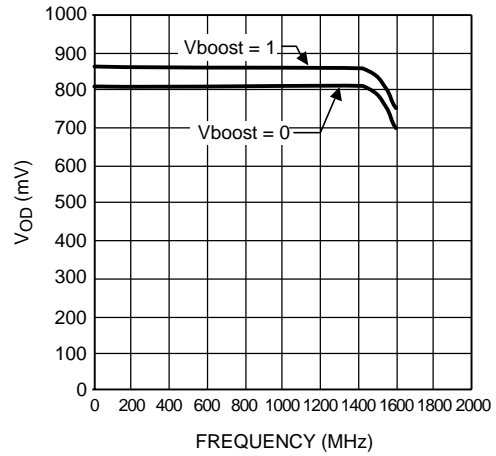

Figure 4-2. LVPECL Vod

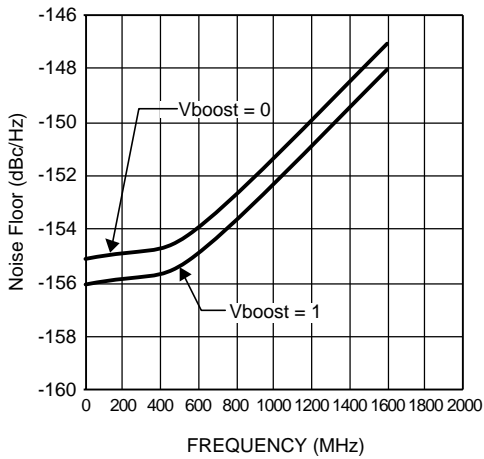

Figure 4-3. LVDS Output Buffer Noise Floor

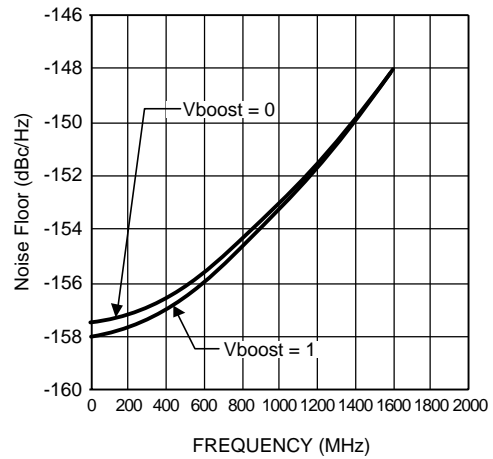
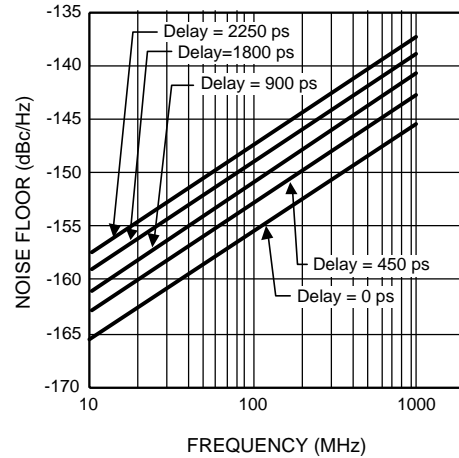

Figure 4-4. LVPECL Output Buffer Noise Floor

To estimate this noise, only the output frequency is required. Divide value and input frequency are not integral.

To estimate this noise, only the output frequency is required. Divide value and input frequency are not integral.



To estimate this noise, only the output frequency is required. Divide value and input frequency are not integral. The noise of the delay block is independent of output type and only applies if the delay is enabled. The noise floor due to the distribution section accounting for the delay noise can be calculated as: Total Output Noise = $10 \times \log(10^{\text{Output Buffer Noise}/10} + 10^{\text{Delay Noise Floor}/10})$.

Figure 4-5. Delay Noise Floor

5 Functional Description

The LMK03200 family of precision clock conditioners combine the functions of jitter cleaning/reconditioning, multiplication, and 0-delay distribution of a reference clock. The devices integrate a Voltage Controlled Oscillator (VCO), a high performance Integer-N Phase Locked Loop (PLL), a partially integrated loop filter, three LVDS, and five LVPECL clock output distribution blocks.

The devices include internal 3rd and 4th order poles to simplify loop filter design and improve spurious performance. The 1st and 2nd order poles are off-chip to provide flexibility for the design of various loop filter bandwidths.

The VCO output is optionally accessible on the Fout port. Internally, the VCO output goes through a VCO divider to feed the various clock distribution blocks.

Each clock distribution block includes a programmable divider, a phase synchronization circuit, a programmable delay, a clock output mux, and an LVDS or LVPECL output buffer. This allows multiple integer-related and phase-adjusted copies of the reference to be distributed to eight system components.

The clock conditioners come in a 48-pin WQFN package and are footprint compatible with other clocking devices in the same family.

5.1 BIAS PIN

To properly use the device, bypass Bias (pin 36) with a low leakage 1 μ F capacitor connected to Vcc. This is important for low noise performance.

5.2 LDO BYPASS

To properly use the device, bypass LDObyp1 (pin 9) with a 10 μ F capacitor and LDObyp2 (pin 10) with a 0.1 μ F capacitor.

5.3 OSCILLATOR INPUT PORT (OSCin, OSCin*)

The purpose of OSCin is to provide the PLL with a reference signal. Due to an internal DC bias the OSCin port should be AC coupled, refer to the [Section 7.1](#) in the [Section 7](#) section. The OSCin port may be driven single-endedly by AC grounding OSCin* with a 0.1 μ F capacitor.

5.4 LOW NOISE, FULLY INTEGRATED VCO

The LMK03200 family of devices contain a fully integrated VCO. For proper operation the VCO uses a frequency calibration routine. The frequency calibration routine is activated any time that the R15 register is programmed and 0_DELAY_MODE = 0. Once the frequency calibration routine is run the temperature may not drift more than the maximum allowable drift for continuous lock, ΔT_{CL} , or else the VCO is not ensured to stay in lock.

The status of the frequency calibration routine can be monitored. See section [Section 6.2](#)

For the frequency calibration routine to work properly OSCin must be driven by a valid signal and VCO_MUX = 0, otherwise the resulting state is unknown.

Refer to [Figure 5-1](#) for a visual representation of what happens when R15 is programmed.

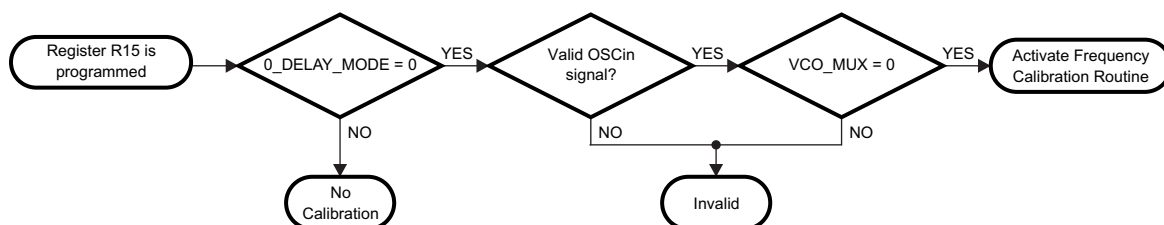

Figure 5-1. Frequency Calibration Routine Flowchart

5.5 LVDS/LVPECL OUTPUTS

By default all the clock outputs are disabled until programmed.

Each LVDS or LVPECL output may be disabled individually by programming the CLKoutX_EN bits. All the outputs may be disabled simultaneously by pulling the GOE pin low or programming EN_CLKout_Global to 0.

The duty cycle of the LVDS and LVPECL clock outputs are shown in the table below.

VCO_DIV	CLKoutX_MUX	Duty Cycle
Any	Divided, or Divided and Delayed	50%
2, 4, 6, 8	Any	50%
3	Bypassed, or Delayed	33%
5	Bypassed, or Delayed	40%
7	Bypassed, or Delayed	43%

5.6 GLOBAL CLOCK OUTPUT SYNCHRONIZATION

The SYNC* pin synchronizes the clock outputs. SYNC* is not used in VCO bypass mode. When the SYNC* pin is held in a logic low state, the divided outputs are also held in a logic low state. The bypassed outputs will continue to operate normally. Shortly after the SYNC* pin goes high, the divided clock outputs are activated and will all transition to a high state simultaneously. All the outputs, divided and bypassed, will now be synchronized. Clocks in the bypassed state are not affected by SYNC* and are always synchronized with the divided outputs.

The SYNC* pin must be held low for greater than one clock cycle of the output of the VCO divider, also known as the distribution path. Once this low event has been registered, the outputs will not reflect the low state for four more cycles. This means that the outputs will be low on the fifth rising edge of the distribution path. Similarly once the SYNC* pin becomes high, the outputs will not simultaneously transition high until four more distribution path clock cycles have passed, which is the fifth rising edge of the distribution path. See the timing diagram in [Figure 5-2](#) for further detail. The clocks are programmed as CLKout0_MUX = Bypassed, CLKout1_MUX = Divided, CLKout1_DIV = 2, CLKout2_MUX = Divided, and CLKout2_DIV = 4. To synchronize the outputs, after the low SYNC* event has been registered, it is not required to wait for the outputs to go low before SYNC* is set high.

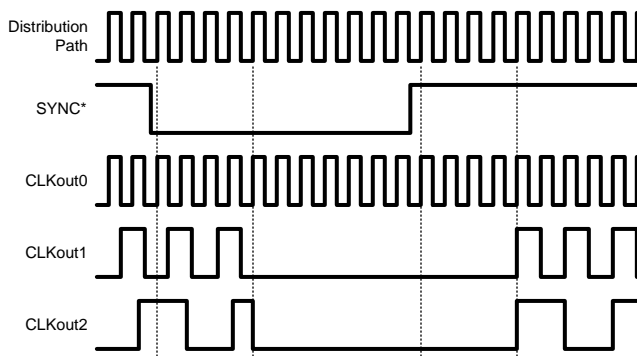

Figure 5-2. SYNC* Timing Diagram

The SYNC* pin provides an internal pull-up resistor as shown on the functional block diagram. If the SYNC* pin is not terminated externally the clock outputs will operate normally. If the SYNC* function is not used, clock output synchronization is not ensured. To ensure 0-delay to reference see [Section 6.2](#).

5.7 CLKout OUTPUT STATES

Each clock output may be individually enabled with the CLKoutX_EN bits. Each individual output enable control bit is gated with the Global Output Enable input pin (GOE) and the Global Output Enable bit (EN_CLKout_Global).

All clock outputs can be disabled simultaneously if the GOE pin is pulled low by an external signal or EN_CLKout_Global is set to 0.

CLKoutX_EN bit	EN_CLKout_Global bit	GOE pin	CLKoutX Output State
1	1	Low	Low
Don't care	0	Don't care	Off
0	Don't care	Don't care	Off
1	1	High / No Connect	Enabled

When an LVDS output is in the Off state, the outputs are at a voltage of approximately 1.5 volts. When an LVPECL output is in the Off state, the outputs are at a voltage of approximately 1 volt.

5.8 GLOBAL OUTPUT ENABLE AND LOCK DETECT

The GOE pin provides an internal pull-up resistor as shown on the functional block diagram. If it is not terminated externally, the clock output states are determined by the Clock Output Enable bits (CLKoutX_EN) and the EN_CLKout_Global bit.

By programming the PLL_MUX register to Digital Lock Detect Active High, the Lock Detect (LD) pin can be connected to the GOE pin in which case all outputs are set low automatically if the synthesizer is not locked.

5.9 POWER ON RESET

When supply voltage to the device increases monotonically from ground to Vcc, the power on reset circuit sets all registers to their default values, see the [Section 6](#) section for more information on default register values. Voltage should be applied to all Vcc pins simultaneously.

5.10 DIGITAL LOCK DETECT

The PLL digital lock detect circuitry compares the difference between the phase of the inputs of the phase detector to a RC generated delay of ϵ . To indicate a locked state the phase error must be less than the ϵ RC delay for 5 consecutive reference cycles. Once in lock, the RC delay is changed to approximately δ . To indicate an out of lock state, the phase error must become greater δ . The values of ϵ and δ are shown in the table below:

ϵ	δ
10 ns	20 ns

To utilize the digital lock detect feature, PLL_MUX must be programmed for "Digital Lock Detect (Active High)" or "Digital Lock Detect (Active Low)." When one of these modes is programmed the state of the LD pin will be set high or low as determined by the description above as shown in Figure 5-3.

When the device is in power down mode and the LD pin is programmed for a digital lock detect function, LD will show a "no lock detected" condition which is low or high given active high or active low circuitry respectively.

The accuracy of this circuit degrades at higher comparison frequencies. To compensate for this, the DIV4 word should be set to one if the comparison frequency exceeds 20 MHz. The function of this word is to divide the comparison frequency presented to the lock detect circuit by 4.

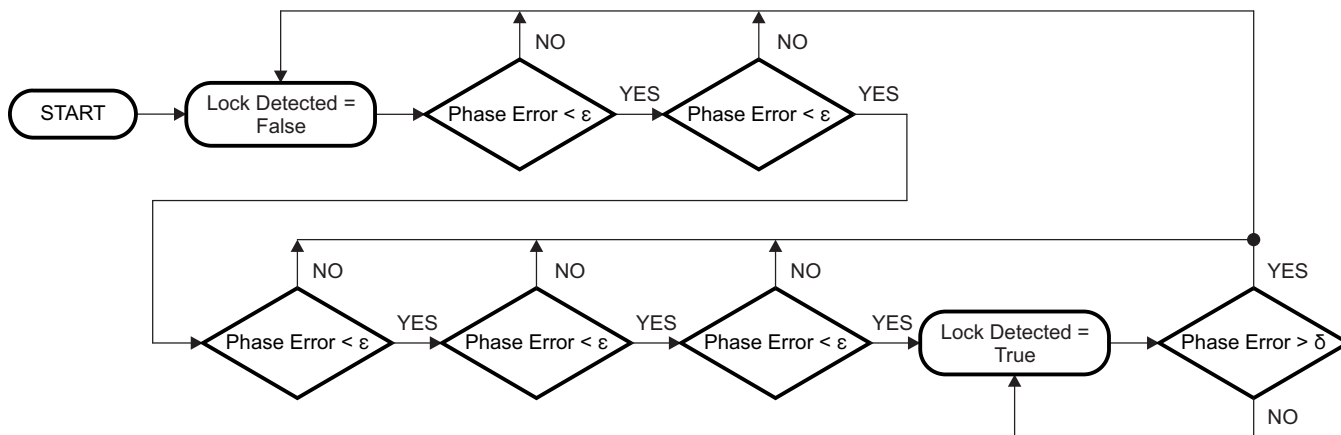

Figure 5-3. Digital Lock Detect Flowchart

5.11 CLKout DELAYS

Each individual clock output includes a delay adjustment. Clock output delay registers (CLKoutX_DLY) support a 150 ps step size and range from 0 to 2250 ps of total delay.

5.12 GLOBAL DELAYS

After the N divider and R divider are two delays PLL_N_DLY and PLL_R_DLY. They support a 150 ps step size and range from 0 to 2250 ps of total delay. When using the 0-delay mode, these delays can be used to cause the clock outputs to lead or lag the clock input phase. Figure 5-4 illustrates the use of the global delays. Note, it is possible to use the individual delays on each clock output (CLKoutX_DLY) to further alter the phase of the various clock outputs. This is not shown in Figure 5-4. Note that Figure 5-4 illustrates use of PLL_N_DLY and PLL_R_DLY to shift clock outputs to lead or lag the reference input phase. It doesn't reflect exact timing or account for delays in buffers internal to the device, meaning the clock output is not ensured to have 0 phase delay from the reference input to a clock output as shown at the pins of the device.

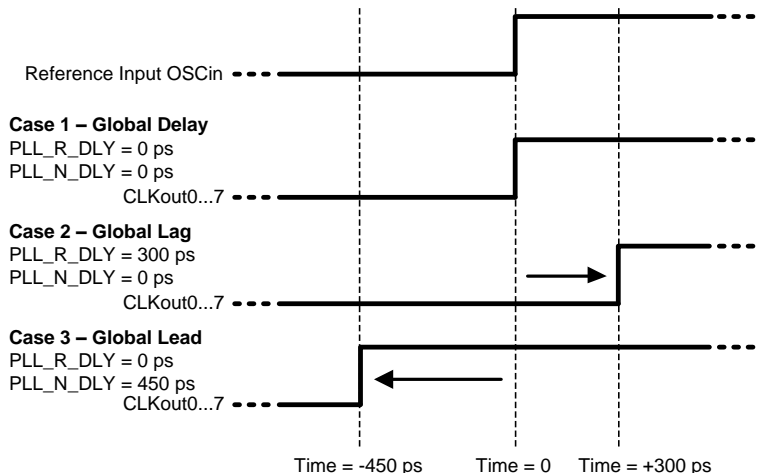

Figure 5-4. Global Lead and Lag

5.13 VCO DIVIDER BYPASS MODE

Once the LMK03200 is locked, the VCO divider may be bypassed to allow a higher frequency at the channel divider inputs, which can be used to generate output frequencies not allowable otherwise. The VCO_DIV bypass mode does not work with 0-delay mode. See programming information in sections [Section 6.3](#) and [Section 6.4.5](#). SYNC* is not used when in VCO divider bypass mode.

5.14 0-DELAY MODE

The LMK03200 family can feedback an output to the phase detector either internally using CLKout5 or CLKout6, or externally by routing any clock output back to the FBCLKin/FBCLKin* input port to be synchronized with the reference clock for 0-delay output.

To ensure 0-delay for all the outputs, the lowest frequency output must be feed back to the PLL. This requirement forces the maximum phase detector frequency \leq the minimum clock output frequency.

When CLKout5 or CLKout6 is used for feedback internally, CLKout5 or CLKout6 are still valid for regular clocking applications. If CLKout5 or CLKout6 are unused, they do not need to be externally terminated, by not terminating the output power consumption is reduced.

To engage the 0-delay mode, refer to programming instructions in section [Section 6.2](#).

[Figure 5-5](#) illustrates the 0-delay mode programming sequence. More detail is in section [Section 6.2](#)

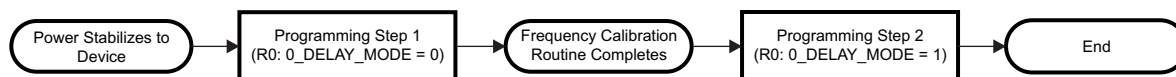

Figure 5-5. Outline of 0-delay mode programming sequence

The 0-delay mode may not be used together with the VCO_DIV bypass except for the purpose of being temporarily enabled to re-program the PLL_N to keep the PLL in lock. See [Section 6.3](#) for more information.

6 General Programming Information

The LMK03200 family of devices are programmed using several 32-bit registers which control the device's operation. The registers consist of a data field and an address field. The last 4 register bits, ADDR [3:0] form the address field. The remaining 28 bits form the data field DATA [27:0].

During programming, LEuWire is low and serial data is clocked in on the rising edge of CLKuWire (MSB first). When LE goes high, data is transferred to the register bank selected by the address field. Only registers R0 to R8, R11, and R13 to R15 need to be programmed for proper device operation.

For the frequency calibration routine to work properly OSCin must be driven by a valid signal when R15 is programmed. Any changes to the PLL_R divider or OSCin require R15 to be programmed again while 0_DELAY_MODE = 0 to activate the frequency calibration routine.

6.1 Recommended Programming Sequence, without 0-Delay Mode

The recommended programming sequence involves programming R0 with the reset bit set (RESET = 1) to ensure the device is in a default state. It is not necessary to program R0 again, but if R0 is programmed again, the reset bit is programmed clear (RESET = 0). Registers are programmed in order with R15 being the last register programmed. An example programming sequence is shown below.

- Program R0 with the reset bit set (RESET = 1). This ensures the device is in a default state. When the reset bit is set in R0, the other R0 bits are ignored.
 - If R0 is programmed again, the reset bit is programmed clear (RESET = 0).
- Program R0 to R7 as necessary with desired clocks with appropriate enable, mux, divider, and delay settings.
- Program R8 for optimum phase noise performance.
- Program R9 with Vboost setting if necessary.
- Program R11 with DIV4 setting if necessary.
- Program R13 with oscillator input frequency and internal loop filter values.
- Program R14 with Fout enable bit, global clock output bit, power down setting, PLL mux setting, and PLL_R divider.
- Program R15 with PLL charge pump gain, VCO divider, and PLL N divider. The frequency calibration routine starts.

6.2 Recommended Programming Sequence, with 0-Delay Mode

The lock procedure when using the 0-delay mode has two steps. The first is to complete the frequency calibration routine for the target frequency while not in 0-delay mode. The second step is to activate 0-delay mode and re-program the PLL_N divider to accommodate the additional divide in the clock output path so that phase lock can be achieved with the reference input clock.

Global_CLK_EN and each output being used should be enabled in step 1. If the user desires for no output from the clock outputs during frequency lock, the GOE pin should be held low.

Step 1

- GOE pin is held low to keep outputs from toggling. Disabling the clock output with MICROWIRE should not be used so that when more than one clock output is used, they will all be synchronized together when using 0_DELAY_MODE. Otherwise a separate SYNC* is required ensure all outputs are synchronized together after all steps are completed.
- Program R0 with the reset bit set (RESET = 1). This ensures the device is in a default state. When the reset bit is set in R0, the other R0 bits are ignored.
 - If R0 is programmed again, the reset bit is programmed clear (RESET = 0).

- Program R0 to R7 as necessary with desired clocks with appropriate enable, mux, divider, and delay settings. Outputs being used should be enabled.
 - R0: DLD_MODE2 = 1 (Digital Lock Detect is now Frequency Calibration Routine Complete)
 - R0: 0_DELAY_MODE = 0
 - R0: FB_MUX = desired feedback path for 0-delay mode.
 - RX: CLKoutX_EN = 1 for used clock outputs.
- Program R8 for optimum phase noise performance.
- Program R9 with Vboost setting if necessary.
- Program R11 with DIV4 setting if necessary.
- Program R13 with oscillator input frequency and internal loop filter values.
- Program R14 with Fout enable bit, global clock output bit, power down setting, PLL mux setting, PLL_R divider, and global PLL R delay.
 - R14: EN_CLKout_Global = 1
 - R14: PLL_MUX = 3 or 4 for frequency calibration routine complete signal.
- Program R15 with PLL charge pump gain, VCO divider, PLL N divider, and global PLL N delay. The frequency calibration routine starts.

Now the LD pin should be monitored for the frequency calibration routine completed signal to be asserted if PLL_MUX was set to 3 or 4 and DLD_MODE2 = 1. Otherwise wait 2 ms for the frequency calibration routine to complete. Once the frequency calibration routine is completed step 2 may be executed to achieve 0-delay mode. With the addition of the clock output divide in the feedback path, the total N feedback divide will change and the device will need to be programmed in this step to accommodate this extra divide.

Step 2

- Program R0 with the same settings as in step 1 except:
 - 0_DELAY_MODE = 1 to activate 0-delay mode.
- The output being used for feedback must be enabled for the device to lock. This means that...
 - GOE pin is high. (set high if low from step 1).
 - SYNC* pin is high.
 - CLKoutX_EN bit is 1. (For all clocks being used)
 - EN_CLKout_Global bit is 1.
- Special feedback cases:
 - When CLKout 5 is used for feedback, CLKout 6 must also be enabled (CLKout6_EN = 1). The configuration of the channel does not matter.
 - When FBCLKin/FBCLKin* is used for feedback, CLKout 5 and CLKout 6 must be enabled (CLKout5_EN = 1 and CLKout6_EN = 1). The configuration of the channels does not matter, except when CLKout 5 or CLKout 6 is the source channel which drives FBCLKin/FBCLKin*.
- Program R15 with new PLL_N value.

The device will now synchronize clock outputs with reference input. As soon as the device is settled the LD pin will be asserted active high or low depending on PLL_MUX value to indicate the device is phase locked. 0_DELAY_MODE = 1 reverts the LD pin back to digital lock detect.

The device is now phase locked and synchronized with the reference clock. Since step 2 requires GOE high for feedback, it is possible that the clock outputs will be momentarily slightly off frequency while the dividers and or feedback paths are being changed. Also when GOE is set high, it is possible for a runt pulse to occur since GOE is an asynchronous input. If there is no concern for off frequency clock cycles then it is allowable to leave GOE high for the entire programming procedure.

Before 0-delay mode the VCO frequency equation is: $VCO \text{ Frequency} = \text{Reference OSCin Frequency} / \text{PLL R Divider} * \text{PLL N Divider} * \text{VCO divider}$.

After 0-delay mode the VCO frequency equation is: VCO Frequency = Reference OSCin Frequency / PLL R Divider * PLL N Divider * VCO divider * CLKoutX_DIV. Where CLKoutX_DIV is the divide value of the clock used for feedback. If the clock is from FBCLKin, any external divides must also be accounted for.

6.2.1 0-Delay Mode Example 1

In this example assume the user requirements are: an input reference of 10 MHz and a clock output of 30 MHz with the clock output synchronized to the reference input clock. CLKout5 is chosen as the output clock because it allows internal feedback for the 0-delay mode.

Registers which are not explicitly programmed are set to default values.

Step 1

- GOE pin is set low.
- Program Register 0 (reset device)
 - RESET = 1
 - Other values don't matter
- Program Register 0 again.
 - RESET = 0
 - DLD_MODE2 = 1 (Digital Lock detect will be used for monitoring frequency calibration routine complete)
 - FB_MUX = 0 (CLKout5 feedback)
- Program Register 5 (30 MHz, used for feedback)
 - CLKout5_EN = 1 (turn output on)
 - CLKout5_MUX = 1 (divided)
 - CLKout5_DIV = 10 (divide by 20)
- Program Register 6 (Must be enabled when using CLKout5 for feedback)
 - CLKout6_EN = 1 (turn output on)
- Program Register 8
- Program Register 14
 - PLL_R = 1 (Phase detector frequency = 10 MHz)
 - PLL_MUX = 3 (DLD Active High)
- Program Register 15 (VCO Frequency = 1200 MHz)
 - PLL_N = 60
 - VCO_DIV = 2
 - PLL_CP_GAIN = Loop filter dependant
- Begin monitoring LD pin for frequency calibration routine complete signal.

The device now begins the frequency calibration routine, when it completes the LD pin will go high since PLL_MUX was programmed with the active high option for the frequency calibration routine complete signal. When the LD pin goes high, step 2 is executed.

Step 2

- Set GOE pin high.
- Program Register 0
 - RESET = 0
 - 0_DELAY_MODE = 1 (activate 0-delay mode)
 - DLD_MODE2 = 1 (same, don't care)
 - FB_MUX = 0 (same)

- Program Register 15 (VCO Frequency = 1200 MHz)
 - PLL_N = 3 (updated value)
 - VCO_DIV = 2 (same)
 - PLL_CP_GAIN = Loop filter dependant

The device will now synchronize. As soon as the device is settled the LD pin will go high to indicate the device is phase locked (0_DELAY_MODE = 1 reverts the LD pin back to digital lock detect mode). Now the device's VCO will be locked to 1200 MHz with an output clock of 30 MHz.

6.2.2 0-Delay Mode Example 2

In this example assume the user requirements are: an input reference of 61.44 MHz and clock outputs of 12.288 MHz (CLKout6), 30.72 MHz (CLKout3), and 61.44 MHz (CLKout4) with the clock outputs synchronized to the reference input clock. CLKout6 is chosen for feedback since the 12.288 MHz clock is the lowest frequency required to be synchronized (0-delay) with the reference and therefore must be fed back to the PLL N divider, note this also limits the phase detector frequency to 12.288 MHz so the input reference must be divided down to 12.288 MHz. If the 12.288 MHz clock wasn't required to be in synchronization (0-delay) with the reference, the 30.72 MHz clock could have been fed back instead raising the maximum allowable phase detector frequency to 30.72 MHz.

Registers which are not explicitly programmed are set to default values.

Step 1

- GOE pin is set low.
- Program Register 0 (reset device)
 - RESET = 1
 - Other values don't matter
- Program Register 0 again.
 - RESET = 0
 - DLD_MODE2 = 1 (Digital Lock detect will be used for monitoring frequency calibration routine complete)
 - FB_MUX = 2 (CLKout6 feedback)
- Program Register 3 (30.72 MHz)
 - CLKout3_EN = 1 (turn output on)
 - CLKout3_MUX = 1 (divided)
 - CLKout3_DIV = 10 (divide by 20)
- Program Register 4 (61.44 MHz)
 - CLKout4_EN = 1 (turn output on)
 - CLKout4_MUX = 1 (divided)
 - CLKout4_DIV = 5 (divide by 10)
- Program Register 6 (12.288 MHz, used for feedback)
 - CLKout6_EN = 1 (turn output on)
 - CLKout6_MUX = 1 (divided)
 - CLKout6_DIV = 25 (divide by 50)
- Program Register 8
- Program Register 14
 - PLL_R = 5 (Phase detector frequency = 12.288 MHz)
 - PLL_MUX = 3 (DLD Active High)
- Program Register 15 (VCO Frequency = 1228.8 MHz)
 - PLL_N = 50
 - VCO_DIV = 2
 - PLL_CP_GAIN = Loop filter dependant

- Begin monitoring LD pin for frequency calibration routine complete signal.

The device now begins the frequency calibration routine, when it completes the LD pin will go high since PLL_MUX was programmed with the active high option for the frequency calibration routine complete signal. When the LD pin goes high, step 2 is executed.

Step 2

- GOE pin is set high.
- Program Register 0
 - RESET = 0
 - 0_DELAY_MODE = 1 (activate 0-delay mode)
 - DLD_MODE2 = 1 (same, don't care)
 - FB_MUX = 2 (CLKout6 feedback)
- Program Register 15 (VCO Frequency = 1228.8 MHz)
 - PLL_N = 1 (updated value)
 - VCO_DIV = 2 (don't care)
 - PLL_CP_GAIN = Loop filter dependant

The device will now synchronize. As soon as the device is settled the LD pin will go high to indicate the device is phase locked (0_DELAY_MODE = 1 reverts the LD pin back to digital lock detect). Now the device's VCO will be locked to 1228.8 MHz with the output clocks of 12.288, 30.72, and 61.44 MHz.

6.3 Recommended Programming Sequence, bypassing VCO divider

The programming procedure when using the VCO mux to bypass the VCO divider has two steps. The first step runs the frequency calibration routine with the VCO divider in the feedback path. The second step bypasses the VCO divider and locks the PLL.

Step 1

- Program R0 with the reset bit set (RESET = 1). This ensures the device is in a default state. When the reset bit is set in R0, the other R0 bits are ignored.
 - If R0 is programmed again, the reset bit is programmed clear (RESET = 0).
- Program R0 to R7 as necessary with desired clocks with appropriate enable, mux, divider, and delay settings.
 - The outputs should be programmed with divider values which achieve desired output frequencies after the VCO divider has been bypassed.
 - R0: DLD_MODE2 = 1 (Digital Lock Detect is now Frequency Calibration Routine Complete)
 - R7: VCO_MUX = 0 (VCO divider output, default)
- Program R8 for optimum phase noise performance.
- Program R9 with Vboost setting if necessary.
- Program R11 with DIV4 setting if necessary.
- Program R13 with oscillator input frequency and internal loop filter values.
- Program R14 with Fout enable bit, global clock output bit, power down setting, PLL mux setting, and PLL_R divider.
 - R14: PLL_MUX = 3 or 4 for frequency calibration routine complete signal.
- Program R15 with PLL charge pump gain, VCO divider, and PLL N divider. The frequency calibration routine starts.

Now the LD pin should be monitored for the frequency calibration routine completed signal to be asserted if PLL_MUX was set to 3 or 4 and DLD_MODE2 = 1. Otherwise wait 2 ms for the frequency calibration routine to complete. Once the frequency calibration routine is completed step 2 may be executed to bypass the VCO divider.

Step 2

- Program R0 with the same settings as step 1 except:
 - DLD_MODE2 = 0 (Digital lock detect is normal)
 - 0_DELAY_MODE = 1 (temporarily enable 0-delay mode)
 - 0_DELAY_MODE is not to be used in VCO divider bypass mode. It is only activated briefly to prevent the frequency calibration routine from running when R15 is programmed while the VCO Mux is selecting the VCO Output directly.
- Program R7
 - VCO_MUX = 2 (VCO output)
- Program R14 with PLL_MUX as desired, or PLL_MUX = 3 or 4 for Lock Detect.
- Program R15 with the updated PLL_N value since the VCO divider is no longer in the feedback path. The updated value of PLL_N = Old PLL_N * VCO_Divider value. This programs the VCO to the same frequency as step 1. The VCO must be programmed for the same frequency as step 1.
- Program R0 with the same settings except:
 - 0_DELAY_MODE = 0 (disable 0-delay mode)

After a short settling time, the VCO will be locked and the clock outputs will be at the desired frequency. The LD pin will indicate when the PLL is locked if PLL_MUX is programmed to a digital lock detect mode.

6.3.1 VCO divider bypass example

In this example assume the user requirements are: an input reference of 61.44 MHz and clock output frequencies of 614.4 MHz on CLKout0 and CLKout1, and 307.2 MHz on CLKout2. The VCO is programmed to 1228.8 MHz.

Registers not explicitly programmed are set to default values.

Step 1

- GOE pin is set high
- Program Register 0 (reset device)
 - RESET = 1
 - Other values don't matter
- Program Register 0 again (614.4 MHz)
 - DLD_MODE2 = 1 (Digital Lock detect will be used for monitoring frequency calibration routine complete)
 - CLKout0_EN = 1 (turn output on)
 - CLKout0_MUX = 0 (bypassed)
- Program Register 1 (614.4 MHz)
 - CLKout1_EN = 1 (turn output on)
 - CLKout1_MUX = 0 (bypassed)
- Program Register 2 (307.2 MHz)
 - CLKout2_EN = 2 (turn output on)
 - CLKout2_MUX = 1 (divide)
 - CLKout2_DIV = 1 (divide by 2)
- Program Register 8
- Program Register 14
 - PLL_R = 2 (Phase detector frequency = 30.72 MHz)
 - PLL_MUX = 3 (DLD Active High, now frequency calibration routine complete)
 - Program Register 15 (VCO Frequency = 1228.8 MHz)
 - PLL_N = 20
 - VCO_DIV = 2
 - PLL_CP_GAIN = Loop filter dependant

- Begin monitoring LD pin lock detect.

The device now begins the frequency calibration routine, when it completes the LD pin will go high since PLL_MUX was programmed with the active high option for lock detect and DLD_MODE2 = 1. When the LD pin goes high, or after 2 ms have passed (the time for frequency calibration routine to complete), step 2 is executed. Note that VCO_DIV = 0 was not programmed to select VCO Divider since that is the default mode.

At this time the clock output frequency will be half the final value because VCO_DIV = 2. If VCO_DIV was = 3, the clock output frequencies would be a third the final value, etc.

Step 2

- Program Register 0
 - DLD_MODE2 = 0 (Digital lock detect is normal)
 - 0_DELAY_MODE = 1 (active 0-delay mode so that programming R15 won't start frequency calibration routine)
 - CLKout0_EN = 1 (keep same programming)
 - CLKout0_MUX = 0 (keep same programming)
- Program Register 7
 - VCO_MUX = 2 (bypass VCO divider)
- Program Register 15 (VCO Frequency = 1228.8 MHz)
 - PLL_N = 40 (VCO_DIV bypassed, must update PLL_N)
- Program Register 0
 - 0_DELAY_MODE = 0
 - CLKout0_EN = 1 (keep same programming)
 - CLKout0_MUX = 0 (keep same programming)

When R7 is updated to bypass the VCO divider the PLL will lose lock until R15 can be updated again with the updated PLL_N divider value.

Once the LD pin goes high again, the clock outputs will be locked at 614.4 MHz and 307.2 MHz.

Table 6-1. Register Map

Register	31	30	29	28	27	26	25	24	23	22	21	20	19	18	17	16	15	14	13	12	11	10	9	8	7	6	5	4	3	2	1	0
	Data [27:0]																											A3	A2	A1	A0	
R0	RESET	0	0	DLD_MODE2	0_DELAY_MODE	FB_MUX [1:0]		0	0	0	0	0	0	0	0	0	0	0	0	0	0	0	0	0	0	0	0	0	0	0	0	0
R1	0	0	0	0	0	0	0	0	0	0	0	0	0	0	0	0	0	0	0	0	0	0	0	0	0	0	0	0	0	0	0	1
R2	0	0	0	0	0	0	0	0	0	0	0	0	0	0	0	0	0	0	0	0	0	0	0	0	0	0	0	0	0	1	0	0
R3	0	0	0	0	0	0	0	0	0	0	0	0	0	0	0	0	0	0	0	0	0	0	0	0	0	0	0	0	0	1	1	0
R4	0	0	0	0	0	0	0	0	0	0	0	0	0	0	0	0	0	0	0	0	0	0	0	0	0	0	0	0	1	0	0	0
R5	0	0	0	0	0	0	0	0	0	0	0	0	0	0	0	0	0	0	0	0	0	0	0	0	0	0	0	0	1	0	1	0
R6	0	0	0	0	0	0	0	0	0	0	0	0	0	0	0	0	0	0	0	0	0	0	0	0	0	0	0	0	1	1	0	0

Table 6-1. Register Map (continued)

Register	31	30	29	28	27	26	25	24	23	22	21	20	19	18	17	16	15	14	13	12	11	10	9	8	7	6	5	4	3	2	1	0
R7	0	0	0	0	0	VCO_MUX [1:0]		0	0	0	0	0	0	0	0	CLKout7_MUX [1:0]	CLKout7_EN	CLKout7_DIV [7:0]							CLKout7_DLY [3:0]			0	1	1	1	
R8	0	0	0	1	0	0	0	0	0	0	0	0	0	0	0	0	0	0	0	0	1	0	0	1	0	0	0	0	1	0	0	0
R9	1	0	1	0	0	0	0	0	0	0	0	0	0	0	1	Vboost	0	0	1	0	1	0	1	0	0	0	0	0	1	0	0	1
R11	0	0	0	0	0	0	0	0	1	0	0	0	0	0	1	0	DI V4	0	0	0	0	0	0	0	0	0	0	0	1	0	1	1
R13	0	0	0	0	0	0	1	0	1	0	OSCin_FREQ [7:0]							VCO_R4_LF [2:0]		VCO_R3_LF [2:0]		VCO_C3_C4_LF [3:0]			1	1	0	1				
R14	0	0	0	EN_Fout	EN_CLKout_Global	POWERDOWN	0	0	PLL_MUX [3:0]			PLL_R [11:0]											PLL_R_DLY [3:0]			1	1	1	0			
R15	PLL_CP_GAIN [1:0]		VCO_DIV [3:0]			PLL_N [17:0]																	PLL_N_DLY [3:0]			1	1	1	1			

6.4 Register R0 to R7

Registers R0 through R7 control the eight clock outputs. Register R0 controls CLKout0, Register R1 controls CLKout1, and so on. There are some additional bit in register R0 called RESET, DLD_MODE2, 0_DELAY_MODE, and FB_MUX. Aside from these, the functions of these bits in registers R0 through R7 are identical. The X in CLKoutX_MUX, CLKoutX_DIV, CLKoutX_DLY, and CLKoutX_EN denote the actual clock output which may be from 0 to 7.

Table 6-2. Default Register Settings after Power on Reset

Bit Name	Default Bit Value	Bit State	Bit Description	Register	Bit Location
RESET	0	No reset, normal operation	Reset to power on defaults	R0	31
DLD_MODE2	0	Disabled	Digital Lock Detect Mode2 is disabled		28
0_DELAY_MODE	0	Disabled	Not 0-delay mode		27
FB_MUX	0	CLKout5	0-delay mode feedback		26:25
CLKoutX_MUX	0	Bypassed	CLKoutX mux mode	R0 to R7	18:17
CLKoutX_EN	0	Disabled	CLKoutX enable		16
CLKoutX_DIV	1	Divide by 2	CLKoutX clock divide		15:8
CLKoutX_DLY	0	0 ps	CLKoutX clock delay		7:4
VCO_MUX	0	Use VCO divider	VCO divider bypassed mode	R7	26:25
Vboost	0	Normal Mode	Output Power Control	R9	16
DIV4	0	PDF \leq 20 MHz	Phase Detector Frequency	R11	15
OSCin_FREQ	10	10 MHz OSCin	OSCin Frequency in MHz	R13	21:14
VCO_R4_LF	0	Low (~200 Ω)	R4 internal loop filter values		13:11
VCO_R3_LF	0	Low (~600 Ω)	R3 internal loop filter values		10:8
VCO_C3_C4_LF	0	C3 = 0 pF, C4 = 10 pF	C3 and C4 internal loop filter values		7:4
EN_Fout	0	Fout disabled	Fout enable	R14	28
EN_CLKout_Global	1	Normal - CLKouts normal	Global clock output enable		27
POWERDOWN	0	Normal - Device active	Device power down		26
PLL_MUX	0	Disabled	Multiplexer control for LD pin		23:20
PLL_R	10	R divider = 10	PLL R divide value	R15	19:8
PLL_R_DLY	0	0 ps	PLL R delay value (lag)		7:4
PLL_CP_GAIN	0	100 μ A	Charge pump current		31:30
VCO_DIV	2	Divide by 2	VCO divide value		29:26
PLL_N	760	N divider = 760	PLL N divide value	R15	25:8
PLL_N_DLY	0	0 ps	PLL N delay value (lead)		7:4

6.4.1 Reset bit -- Reset device to power on defaults

This bit is only in register R0. The use of this bit is optional and it should be set to '0' if not used. Setting this bit to a '1' forces all registers to their power on reset condition and therefore automatically clears this bit. If this bit is set, all other R0 bits are ignored and R0 needs to be programmed again if used with its proper values and RESET = 0.

6.4.2 DLD_MODE2 bit -- Digital Lock Detect Mode 2

This bit is only in register R0. The output of the LD pin is defined by register PLL_MUX (See [Section 6.9.2](#)). When a Digital Lock Detect output is selected, setting this bit overrides the default functionality allowing the user to determine when the frequency calibration routine is done. When using 0-delay mode this informs the user when the 0-delay mode can be activated. See [Section 6.2](#) for more information.

DLD_MODE2	0_DELAY_MODE	LD Output
0 (default)	X	Digital Lock Detect
1	0	Digital Calibration Complete
1	1	Digital Lock Detect

6.4.3 0_DELAY_MODE bit -- Activate 0-Delay Mode

This bit is only in register R0 and is used for activating the 0-delay mode. Once the frequency calibration routine is complete - as determined by monitoring the LD output in DLD_MODE2 or waiting 2 ms after programming R15, this bit may be set to activate 0-delay mode. Setting this bit sets the N divider mux to use the feedback mux for input and prevents the frequency calibration routine from activating when register R15 is programmed. Once this bit is set and the 0-delay path is completed, the PLL_N divider in register R15 will need to be reprogrammed for final phase lock. See [Section 6.2](#) for more information. Also refer to [Section 6.4.4](#) for more information on proper configuration of the device for feedback of the selected signal.

0_DELAY_MODE	Frequency Calibration Routine	N divider mux (Ndiv Mux)
0 (default)	Enabled	VCO Divider
1	Disabled	Feedback Mux (FB_MUX)

6.4.4 FB_MUX [1:0] -- Feedback Mux

This bit is only in register R0 and is for use with the 0-delay mode.

FB_MUX [1:0]	Mode
0	CLKout5 (default)
1	FBCLKin/FBCLKin* Input
2	CLKout6
3	Reserved

When using CLKout5 and FBCLKin/FBCLKin* for feedback for 0-delay mode, the proper clock outputs must be enabled to pass the feedback signal back to the N divider. Refer to the table below for more details. The only requirement given by the table below is that the clock output must be enabled with CLKoutX_EN bits, if the clock is only used for feedback, the clock does not need to be terminated which saves power. The simplest feedback path to use is CLKout6 since it does not require another CLKout to be enabled.

Clock Feedback Source	CLKout5_EN (See CLKoutX_EN bit)	CLKout6_EN (See CLKoutX_EN bit)
CLKout 5	1	1
FBCLKin/FBCLKin*	1	1
CLKout 6	Don't care	1

The electrical specification $td_{0-DELAY}$ is given with the condition $FB_MUX = 0$ (CLKout5). If $FB_MUX = 2$ (CLKout6), then $td_{0-DELAY}$, OSCin to CLKoutX 0-delay, increases 100 ps.

6.4.5 VCO_MUX [1:0] -- VCO Mux

This bit is only in register R7 and is used to select either the VCO divider output or the VCO output for the clock distribution path. By selecting the VCO output (VCO_MUX=2), the VCO divider is bypassed allowing a higher frequency at the channel divider inputs, which can be used to generate output frequencies not allowable otherwise.

Important: The VCO calibration routine requires that the VCO divider (VCO_MUX = 0) is selected when programming R15.

The VCO divider (VCO_MUX=0) must be selected for the VCO calibration routine to operate properly.

Important: When bypassing the VCO divider (VCO_MUX=2), 0-delay mode may not be used. However 0_DELAY_MODE is set to 1 when re-programming PLL_N after the VCO divider has been bypassed to prevent the frequency calibration routine from running. The new PLL_N value = Old PLL_N * VCO divider. Once PLL_N is re-programmed 0_DELAY_MODE is set back to 0. See the programming section, [Section 6.3](#), for more information.

VCO_MUX [1:0]	Mode
0	VCO Divider (default)
1	Reserved
2	VCO
3	Reserved

6.4.6 CLKoutX_MUX [1:0] -- Clock Output Multiplexers

These bits control the Clock Output Multiplexer for each clock output. Changing between the different modes changes the blocks in the signal path and therefore incurs a delay relative to the bypass mode. The different MUX modes and associated delays are listed below.

CLKoutX_MUX [1:0]	Mode	Added Delay Relative to Bypass Mode
0	Bypassed (default)	0 ps
1	Divided	100 ps
2	Delayed	400 ps (In addition to the programmed delay)
3	Divided and Delayed	500 ps (In addition to the programmed delay)

6.4.7 CLKoutX_DIV [7:0] -- Clock Output Dividers

These bits control the clock output divider value. In order for these dividers to be active, the respective CLKoutX_MUX bit must be set to either "Divided" or "Divided and Delayed" mode. After all the dividers are programmed, the SYNC* pin must be used to ensure that all edges of the clock outputs are aligned. The Clock Output Dividers follow the VCO Divider so the final clock divide for an output is VCO Divider × Clock Output Divider. By adding the divider block to the output path a fixed delay of approximately 100 ps is incurred.

The actual Clock Output Divide value is twice the binary value programmed as listed in the table below.

CLKoutX_DIV [7:0]								Clock Output Divider value
0	0	0	0	0	0	0	0	Invalid
0	0	0	0	0	0	0	1	2 (default)
0	0	0	0	0	0	1	0	4
0	0	0	0	0	0	1	1	6
0	0	0	0	0	1	0	0	8
0	0	0	0	0	1	0	1	10
.
1	1	1	1	1	1	1	1	510

6.4.8 CLKoutX_DLY [3:0] -- Clock Output Delays

These bits control the delay stages for each clock output. In order for these delays to be active, the respective CLKoutX_MUX bit must be set to either "Delayed" or "Divided and Delayed" mode. By adding the delay block to the output path a fixed delay of approximately 400 ps is incurred in addition to the delay shown in the table below.

CLKoutX_DLY [3:0]	Delay (ps)
0	0 (default)
1	150
2	300
3	450
4	600
5	750
6	900
7	1050
8	1200
9	1350
10	1500
11	1650
12	1800
13	1950
14	2100
15	2250

6.4.9 CLKoutX_EN bit -- Clock Output Enables

These bits control whether an individual clock output is enabled or not. If the EN_CLKout_Global bit is set to zero or if GOE pin is held low, all CLKoutX_EN bit states will be ignored and all clock outputs will be disabled.

CLKoutX_EN bit	Conditions	CLKoutX State
0	EN_CLKout_Global bit = 1 GOE pin = High / No Connect	Disabled (default)
1		Enabled

6.5 Register R8

There are no user programmable bits in register R8. Register R8 is programmed as shown in the section for optimum phase noise performance.

6.6 Register R9

The programming of register R9 is optional. If it is not programmed the bit Vboost will be defaulted to 0, which is the test condition for all electrical characteristics.

6.6.1 Vboost bit -- Voltage Boost

By enabling this bit, the voltage output levels for all clock outputs is increased. Also, the noise floor is improved

Vboost	Typical LVDS Voltage Output (mV)	Typical LVPECL Voltage Output (mV)
0	350	810
1	390	865

6.7 Register R11

This register only has one bit and only needs to be programmed in the case that the phase detector frequency is greater than 20 MHz and digital lock detect is used. Otherwise, it is automatically defaulted to the correct values.

6.7.1 DIV4 -- High Phase Detector Frequencies and Lock Detect

This bit divides the frequency presented to the digital lock detect circuitry by 4. It is necessary to get a reliable output from the digital lock detect output in the case of a phase detector frequency greater than 20 MHz.

DIV4	Digital Lock Detect Circuitry Mode
0	Not divided Phase Detector Frequency \leq 20 MHz (default)
1	Divided by 4 Phase Detector Frequency > 20 MHz

6.8 Register R13

6.8.1 VCO_C3_C4_LF [3:0] -- Value for Internal Loop Filter Capacitors C3 and C4

These bits control the capacitor values for C3 and C4 in the internal loop filter.

VCO_C3_C4_LF [3:0]	Loop Filter Capacitors	
	C3 (pF)	C4 (pF)
0	0 (default)	10 (default)
1	0	60
2	50	10
3	0	110
4	50	110
5	100	110
6	0	160
7	50	160
8	100	10
9	100	60
10	150	110
11	150	60
12 to 15	Invalid	

6.8.2 VCO_R3_LF [2:0] -- Value for Internal Loop Filter Resistor R3

These bits control the R3 resistor value in the internal loop filter. The recommended setting for VCO_R3_LF[2:0] = 0 for optimum phase noise and jitter.

VCO_R3_LF[2:0]	R3 Value (kΩ)
0	Low (~600 Ω) (default)
1	10
2	20
3	30
4	40
5 to 7	Invalid

6.8.3 VCO_R4_LF [2:0] -- Value for Internal Loop Filter Resistor R4

These bits control the R4 resistor value in the internal loop filter. The recommended setting for VCO_R4_LF[2:0] = 0 for optimum phase noise and jitter.

VCO_R4_LF[2:0]	R4 Value (kΩ)
0	Low (~200 Ω) (default)
1	10
2	20
3	30
4	40
5 to 7	Invalid

6.8.4 OSCin_FREQ [7:0] -- Oscillator Input Calibration Adjustment

These bits are to be programmed to the OSCin frequency. If the OSCin frequency is not an integral multiple of 1 MHz, then round to the closest value.

OSCin_FREQ [7:0]	OSCin Frequency
1	1 MHz
2	2 MHz
...	...
10	10 MHz (default)
...	...
200	200 MHz
201 to 255	Invalid

6.9 Register R14

6.9.1 PLL_R [11:0] -- R Divider Value

These bits program the PLL R Divider and are programmed in binary fashion. Any changes to PLL_R require R15 to be programmed again while 0_DELAY_MODE = 0 to active the frequency calibration routine.

PLL_R [11:0]												PLL R Divide Value
0	0	0	0	0	0	0	0	0	0	0	0	Invalid
0	0	0	0	0	0	0	0	0	0	0	1	1
0	0	0	0	0	0	0	0	0	0	1	0	2
.
0	0	0	0	0	0	0	0	1	0	1	0	10 (default)
.
1	1	1	1	1	1	1	1	1	1	1	1	4095

6.9.2 PLL_MUX[3:0] -- Multiplexer Control for LD Pin

These bits set the output mode of the LD pin. The table below lists several different modes. Note that PLL_MUX = 3 and PLL_MUX = 4 have alternate functionality if DLD_MODE2 (section [Section 6.4.2](#)) is set.

PLL_MUX [3:0]	Output Type	LD Pin Function
0	Hi-Z	Disabled (default)
1	Push-Pull	Logic High
2	Push-Pull	Logic Low
3	Push-Pull	Digital Lock Detect (Active High) (1)
4	Push-Pull	Digital Lock Detect (Active Low) (2)
5	Push-Pull	Analog Lock Detect
6	Open Drain NMOS	Analog Lock Detect
7	Open Drain PMOS	Analog Lock Detect
8	Invalid	
9	Push-Pull	N Divider Output/2 (50% Duty Cycle)
10	Invalid	
11	Push-Pull	R Divider Output/2 (50% Duty Cycle)
12 to 15	Invalid	

- (1) If DLD_MODE2 is set, this functionality is redefined to "Frequency Calibration Routine Complete (Active High)." See [Section 6.4.2](#) for more information.
- (2) If DLD_MODE2 is set, this functionality is redefined to "Frequency Calibration Routine Complete (Active Low)." See [Section 6.4.2](#) for more information.

Analog Lock Detect outputs the state of the charge pump on the LD pin. While the charge pump is on, the LD pin is low. While the charge pump is off, the LD pin is high. By using two resistors, a capacitor, diode, and comparator a lock detect circuit may be constructed. (For more information on lock detect circuits, see chapter 32 of PLL Performance, Simulation and Design Handbook, Fourth Edition by Dean Banerjee.) When in lock the charge pump will only turn on momentarily once every period of the phase detector frequency. "N Divider Output/2" and "R Divider Output/2" output half the frequency of the phase detector on the LD pin. When the device is locked, these frequencies should be the same. These options are useful for debugging.

6.9.3 POWERDOWN bit -- Device Power Down

This bit can power down the device. Enabling this bit powers down the entire device and all blocks, regardless of the state of any of the other bits or pins.

POWERDOWN bit	Mode
0	Normal Operation (default)
1	Entire Device Powered Down

6.9.4 EN_CLKout_Global bit -- Global Clock Output Enable

This bit overrides the individual CLKoutX_EN bits. When this bit is set to 0, all clock outputs are disabled, regardless of the state of any of the other bits or pins.

EN_CLKout_Global bit	Clock Outputs
0	All Off
1	Normal Operation (default)

6.9.5 EN_Fout bit -- Fout port enable

This bit enables the Fout pin.

EN_Fout bit	Fout Pin Status
0	Disabled (default)
1	Enabled

6.9.6 PLL_R_DLY [3:0] - Global Skew Adjust, Lag

These bits control the delay stage in front of the R input of the phase detector. The affect of adjusting this delay is to lag the phase of the clock outputs uniformly from the clock input phase by the specified amount.

PLL_R_DLY[3:0]	Delay (ps)
0	0 (default)
1	150
2	300
3	450
4	600
5	750
6	900
7	1050
8	1200
9	1350
10	1500
11	1650
12	1800
13	1950
14	2100
15	2250

6.10 REGISTER R15

Programming R15 also activates the frequency calibration routine while `0_DELAY_MODE = 0`. Programming R15 also causes a global synchronization operation. See sections [Section 6.4.3](#) and [Section 5.6](#) respectively for more information.

6.10.1 PLL_N [17:0] -- PLL N Divider

These bits program the divide value for the PLL N Divider. The PLL N Divider follows the VCO Divider and precedes the PLL phase detector. Since the VCO Divider is also in the feedback path from the VCO to the PLL Phase Detector, the total N divide value, N_{Total} , is also influenced by the VCO Divider value. $N_{Total} = \text{PLL N Divider} \times \text{VCO Divider}$. The VCO frequency is calculated as, $f_{VCO} = f_{OSCin} \times \text{PLL N Divider} \times \text{VCO Divider} / \text{PLL R Divider}$. Since the PLL N divider is a pure binary counter there are no illegal divide values for PLL_N [17:0] except for 0.

PLL_N [17:0]																	PLL N Divider Value	
0	0	0	0	0	0	0	0	0	0	0	0	0	0	0	0	0	0	Invalid
0	0	0	0	0	0	0	0	0	0	0	0	0	0	0	0	0	1	1
.
0	0	0	0	0	0	0	0	0	1	0	1	1	1	1	1	0	0	760 (default)
.
1	1	1	1	1	1	1	1	1	1	1	1	1	1	1	1	1	1	262143

6.10.2 VCO_DIV [3:0] -- VCO Divider

These bits program the divide value for the VCO Divider. The VCO Divider follows the VCO output and precedes the clock distribution blocks. Since the VCO Divider is in the feedback path from the VCO to the PLL phase detector the VCO Divider contributes to the total N divide value, N_{Total} . $N_{Total} = \text{PLL N Divider} \times \text{VCO Divider}$. The VCO Divider can not be bypassed. See [Section 6.10.1](#) for more information on setting the VCO frequency.

VCO_DIV [3:0]				VCO Divider Value
0	0	0	0	Invalid
0	0	0	1	Invalid
0	0	1	0	2 (default)
0	0	1	1	3
0	1	0	0	4
0	1	0	1	5
0	1	1	0	6
0	1	1	1	7
1	0	0	0	8
1	0	0	1	Invalid
.
1	1	1	1	Invalid

6.10.3 PLL_CP_GAIN [1:0] -- PLL Charge Pump Gain

These bits set the charge pump gain of the PLL.

PLL_CP_GAIN [1:0]	Charge Pump Gain
0	1x (default)
1	4x
2	16x
3	32x

6.10.4 PLL_N_DLY [3:0] - Global Skew Adjust, Lead

These bits control the delay stage in front of the N input of the phase detector. The affect of adjusting this delay is to lead the phase of the clock outputs uniformly from the clock input phase by the specified amount.

PLL_N_DLY [3:0]	Delay (ps)
0	0 (default)
1	150
2	300
3	450
4	600
5	750
6	900
7	1050
8	1200
9	1350
10	1500
11	1650
12	1800
13	1950
14	2100
15	2250

7 Application Information

7.1 SYSTEM LEVEL DIAGRAM

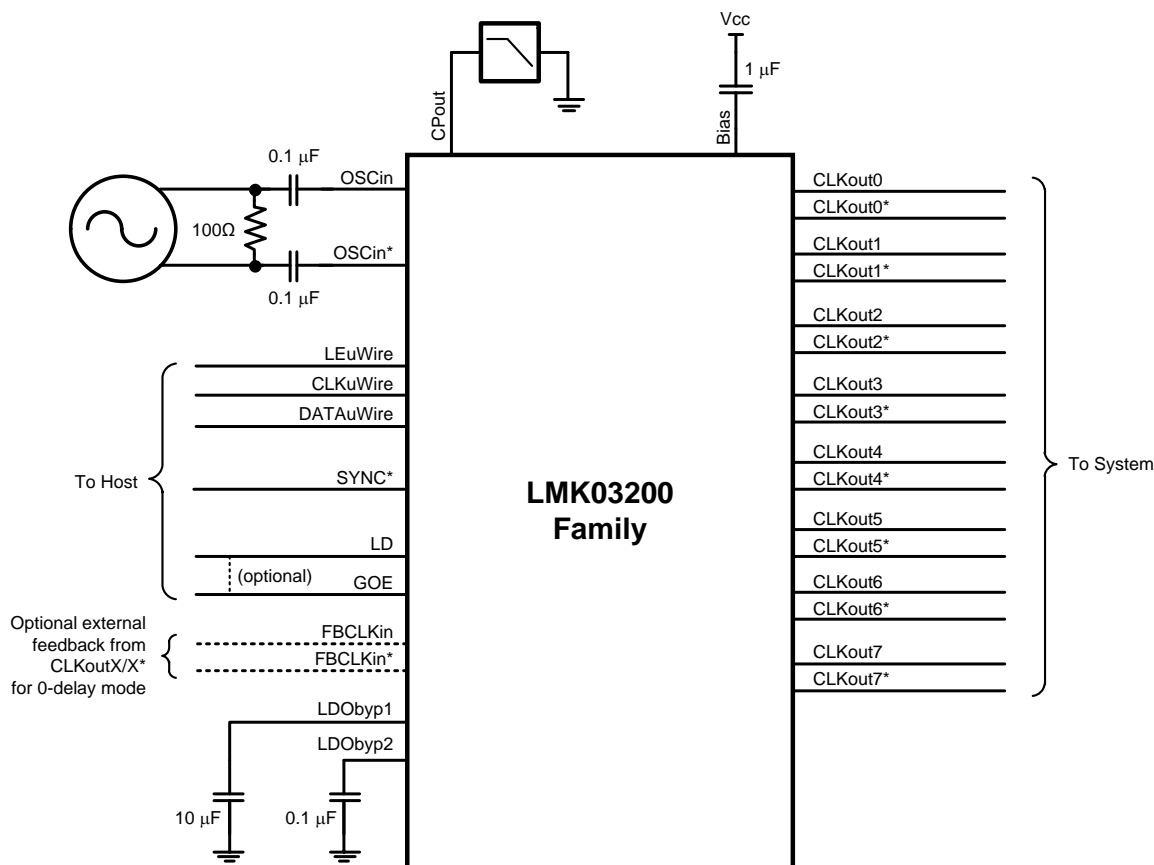

Figure 7-1. Typical Application

Figure 7-1 shows an LMK03200 family device used in a typical application. In this setup the clock may be multiplied, reconditioned, and redistributed. Both the OSCin/OSCin* and CLKoutX/CLKoutX* pins can be used in a single-ended or a differential fashion, which is discussed later in this datasheet. The GOE pin needs to be high for the outputs to operate. One technique sometimes used is to take the output of the LD (Lock Detect) pin and use this as an input to the GOE pin. If this is done, then the outputs will turn off if lock detect circuit detects that the PLL is out of lock. The loop filter actually consists of seven components, but four of these components that for the third and fourth poles of the loop filter are integrated in the chip. The first and second pole of the loop filter are external.

7.2 BIAS PIN

See section [Section 5.1](#) for more information.

7.3 LDO BYPASS

See section [Section 5.2](#) for more information.

7.4 LOOP FILTER

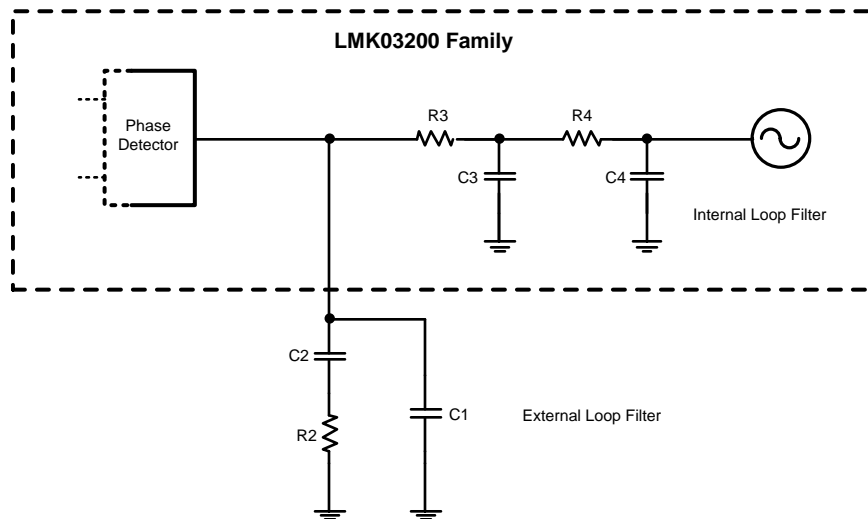

Figure 7-2. Loop Filter

The internal charge pump is directly connected to the integrated loop filter components. The first and second pole of the loop filter are externally attached as shown in [Figure 7-2](#). When the loop filter is designed, it must be stable over the entire frequency band, meaning that the changes in $K_{V_{tune}}$ from the low to high band specification will not make the loop filter unstable. The design of the loop filter is application specific and can be rather involved, but is discussed in depth in the Clock Conditioner Owner's Manual provided by Texas Instruments. When designing with the integrated loop filter of the LMK03200 family, considerations for minimum resistor thermal noise often lead one to the decision to design for the minimum value for integrated resistors, R3 and R4. Both the integrated loop filter resistors and capacitors (C3 and C4) also restrict how wide the loop bandwidth the PLL can have. However, these integrated components do have the advantage that they are closer to the VCO and can therefore filter out some noise and spurs better than external components. For this reason, a common strategy is to minimize the internal loop filter resistors and then design for the largest internal capacitor values that permit a wide enough loop bandwidth. In some situations where spurs requirements are very stringent and there is margin on phase noise, it might make sense to design for a loop filter with integrated resistor values that are larger than their minimum value.

7.5 CURRENT CONSUMPTION / POWER DISSIPATION CALCULATIONS

Due to the myriad of possible configurations the following table serves to provide enough information to allow the user to calculate estimated current consumption of the device. Unless otherwise noted $V_{cc} = 3.3$ V, $T_A = 25$ °C.

Table 7-1. Block Current Consumption

Block	Condition	Current Consumption at 3.3 V (mA)	Power Dissipated in device (mW)	Power Dissipated in LVPECL emitter resistors (mW)
Entire device, core current	All outputs off; No LVPECL emitter resistors connected	86.0	283.8	-
Low clock buffer (internal)	The low clock buffer is enabled anytime one of CLKout0 through CLKout3 are enabled	9	29.7	-
High clock buffer (internal)	The high clock buffer is enabled anytime one of the CLKout4 through CLKout7 are enabled	9	29.7	-
Output buffers	Fout buffer, EN_Fout = 1	14.5	47.8	-
	LVDS output, Bypassed mode	17.8	58.7	-
	LVPECL output, Bypassed mode (includes 120 Ω emitter resistors)	40	72	60
	LVPECL output, disabled mode (includes 120 Ω emitter resistors)	17.4	38.3	19.1
	LVPECL output, disabled mode. No emitter resistors placed; open outputs	0	0	-
Divide circuitry per output	Divide enabled, divide = 2	5.3	17.5	-
	Divide enabled, divide > 2	8.5	28.0	-
Delay circuitry per output, PLL_R_DLY, or PLL_N_DLY	Delay enabled, delay < 8	5.8	19.1	-
	Delay enabled, delay > 7	9.9	32.7	-
Entire device	CLKout0 & CLKout4 enabled in Bypassed mode	161.8	474	60

From Table 3.5 the current consumption can be calculated in any configuration. For example, the current for the entire device with 1 LVDS (CLKout0) & 1 LVPECL (CLKout4) output in Bypassed mode can be calculated by adding up the following blocks: core current, low clock buffer, high clock buffer, one LVDS output buffer current, and one LVPECL output buffer current. There will also be one LVPECL output drawing emitter current, but some of the power from the current draw is dissipated in the external 120 Ω resistors which doesn't add to the power dissipation budget for the device. If delays or divides are switched in, then the additional current for these stages needs to be added as well.

For power dissipated by the device, the total current entering the device is multiplied by the voltage at the device minus the power dissipated in any emitter resistors connected to any of the LVPECL outputs. If no emitter resistors are connected to the LVPECL outputs, this power will be 0 watts. For example, in the case of 1 LVDS (CLKout0) & 1 LVPECL (CLKout4) operating at 3.3 volts, we calculate $3.3 \text{ V} \times (86 + 9 + 9 + 17.8 + 40) \text{ mA} = 3.3 \text{ V} \times 161.8 \text{ mA} = 533.9 \text{ mW}$. Because the LVPECL output (CLKout4) has the emitter resistors hooked up and the power dissipated by these resistors is 60 mW, the total device power dissipation is $533.9 \text{ mW} - 60 \text{ mW} = 473.9 \text{ mW}$.

When the LVPECL output is active, ~1.9 V is the average voltage on each output as calculated from the LVPECL V_{oh} & V_{ol} typical specification. Therefore the power dissipated in each emitter resistor is approximately $(1.9 \text{ V})^2 / 120 \text{ } \Omega = 30 \text{ mW}$. When the LVPECL output is disabled, the emitter resistor voltage is ~1.07 V. Therefore the power dissipated in each emitter resistor is approximately $(1.07 \text{ V})^2 / 120 \text{ } \Omega = 9.5 \text{ mW}$.

7.6 THERMAL MANAGEMENT

Power consumption of the LMK03200 family of devices can be high enough to require attention to thermal management. For reliability and performance reasons the die temperature should be limited to a maximum of 125 °C. That is, as an estimate, T_A (ambient temperature) plus device power consumption times θ_{JA} should not exceed 125 °C.

The package of the device has an exposed pad that provides the primary heat removal path as well as excellent electrical grounding to the printed circuit board. To maximize the removal of heat from the package a thermal land pattern including multiple vias to a ground plane must be incorporated on the PCB within the footprint of the package. The exposed pad must be soldered down to ensure adequate heat conduction out of the package. A recommended land and via pattern can be downloaded from TI's packaging website. See WQFN footprint gerbers at: <http://www.ti.com/packaging>.

To minimize junction temperature it is recommended that a simple heat sink be built into the PCB (if the ground plane layer is not exposed). This is done by including a copper area of about 2 square inches on the opposite side of the PCB from the device. This copper area may be plated or solder coated to prevent corrosion but should not have conformal coating (if possible), which could provide thermal insulation. The vias should top and bottom copper layers to the ground layer. These vias act as "heat pipes" to carry the thermal energy away from the device side of the board to where it can be more effectively dissipated.

7.7 TERMINATION AND USE OF CLOCK OUTPUTS (DRIVERS)

When terminating clock drivers keep in mind these guidelines for optimum phase noise and jitter performance:

- Transmission line theory should be followed for good impedance matching to prevent reflections.
- Clock drivers should be presented with the proper loads. For example:
 - LVDS drivers are current drivers and require a closed current loop.
 - LVPECL drivers are open emitter and require a DC path to ground.
- Receivers should be presented with a signal biased to their specified DC bias level (common mode voltage) for proper operation. Some receivers have self-biasing inputs that automatically bias to the proper voltage level. In this case, the signal should normally be AC coupled.

It is possible to drive a non-LVPECL or non-LVDS receiver with a LVDS or LVPECL driver as long as the above guidelines are followed. Check the datasheet of the receiver or input being driven to determine the best termination and coupling method to be sure that the receiver is biased at its optimum DC voltage (common mode voltage). For example, when driving the OSCin/OSCin* input of the LMK03200 family, OSCin/OSCin* should be AC coupled because OSCin/OSCin* biases the signal to the proper DC level, see [Figure 7-1](#). This is only slightly different from the AC coupled cases described in [Section 7.7.2](#) because the DC blocking capacitors are placed between the termination and the OSCin/OSCin* pins, but the concept remains the same, which is the receiver (OSCin/OSCin*) set the input to the optimum DC bias voltage (common mode voltage), not the driver.

7.7.1 Termination for DC Coupled Differential Operation

For DC coupled operation of an LVDS driver, terminate with $100\ \Omega$ as close as possible to the LVDS receiver as shown in [Figure 7-3](#). The LVDS driver will provide the DC bias level for the LVDS receiver.

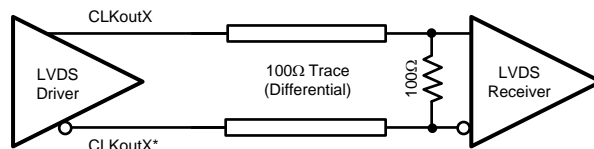

Figure 7-3. Differential LVDS Operation, DC Coupling

For DC coupled operation of an LVPECL driver, terminate with $50\ \Omega$ to $V_{CC} - 2\text{ V}$ as shown in [Figure 7-4](#). Alternatively terminate with a Thevenin equivalent circuit ($120\ \Omega$ resistor connected to V_{CC} and an $82\ \Omega$ resistor connected to ground with the driver connected to the junction of the $120\ \Omega$ and $82\ \Omega$ resistors) as shown in [Figure 7-5](#) for $V_{CC} = 3.3\text{ V}$.

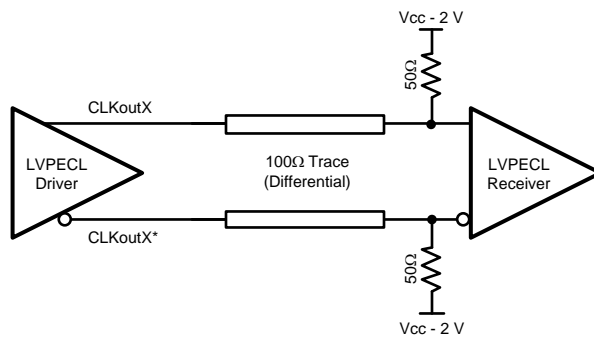

Figure 7-4. Differential LVPECL Operation, DC Coupling

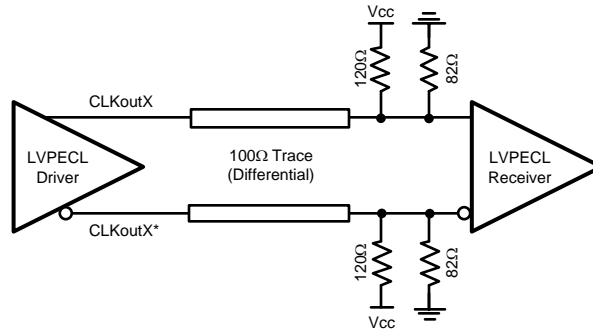

Figure 7-5. Differential LVPECL Operation, DC Coupling, Thevenin Equivalent

7.7.2 Termination for AC Coupled Differential Operation

AC coupling allows for shifting the DC bias level (common mode voltage) when driving different receiver standards. Since AC coupling prevents the driver from providing a DC bias voltage at the receiver it is important to ensure the receiver is biased to its ideal DC level.

When driving LVDS receivers with an LVDS driver, the signal may be AC coupled by adding DC blocking capacitors, however the proper DC bias point needs to be established at the receiver. One way to do this is with the termination circuitry in Figure 7-6.

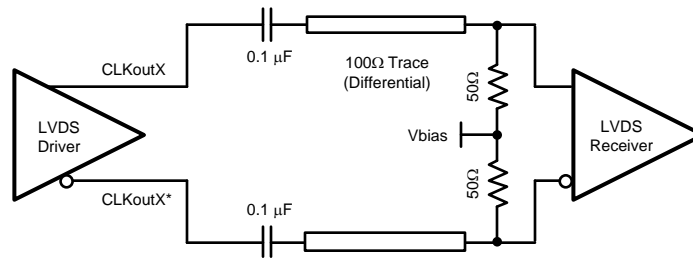

Figure 7-6. Differential LVDS Operation, AC Coupling

LVPECL drivers require a DC path to ground. When AC coupling an LVPECL signal use 120 Ω emitter resistors close to the LVPECL driver to provide a DC path to ground as shown in Figure 7-7. For proper receiver operation, the signal should be biased to the DC bias level (common mode voltage) specified by the receiver. The typical DC bias voltage (common mode voltage) for LVPECL receivers is 2 V. A Thevenin equivalent circuit (82 Ω resistor connected to Vcc and a 120 Ω resistor connected to ground with the driver connected to the junction of the 82 Ω and 120 Ω resistors) is a valid termination as shown in Figure 7-7 for Vcc = 3.3 V. Note this Thevenin circuit is different from the DC coupled example in Figure 7-5.

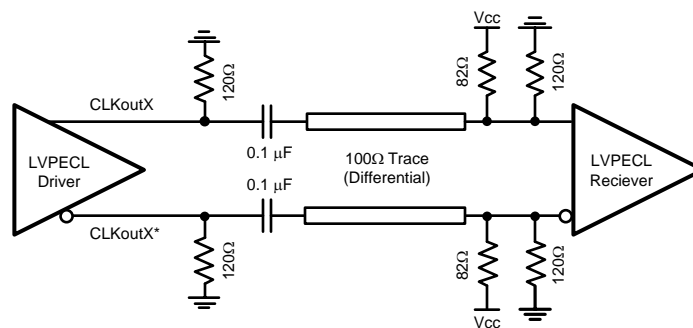

Figure 7-7. Differential LVPECL Operation, AC Coupling, Thevenin Equivalent

7.7.3 Termination for Single-Ended Operation

A balun can be used with either LVDS or LVPECL drivers to convert the balanced, differential signal into an unbalanced, single-ended signal.

It is possible to use an LVPECL driver as one or two separate 800 mV p-p signals. When DC coupling one of the LMK03200 family clock LVPECL drivers, the termination should still be 50 ohms to $V_{CC} - 2\text{ V}$ as shown in Figure 7-8. Again the Thevenin equivalent circuit (120 Ω resistor connected to V_{CC} and an 82 Ω resistor connected to ground with the driver connected to the junction of the 120 Ω and 82 Ω resistors) is a valid termination as shown in Figure 7-9 for $V_{CC} = 3.3\text{ V}$.

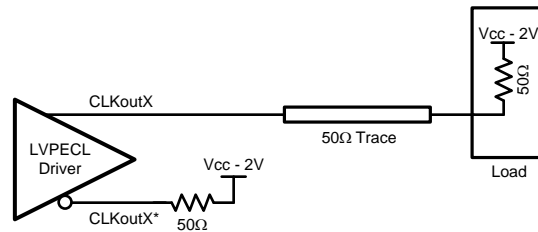

Figure 7-8. Single-Ended LVPECL Operation, DC Coupling

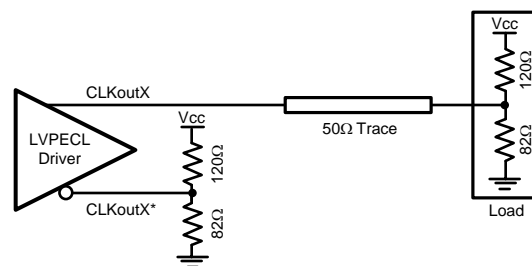

Figure 7-9. Single-Ended LVPECL Operation, DC Coupling, Thevenin Equivalent

When AC coupling an LVPECL driver use a 120 Ω emitter resistor to provide a DC path to ground and ensure a 50 ohm termination with the proper DC bias level for the receiver. The typical DC bias voltage for LVPECL receivers is 2 V (See Section 7.7.2). If the other driver is not used it should be terminated with either a proper AC or DC termination. This latter example of AC coupling a single-ended LVPECL signal can be used to measure single-ended LVPECL performance using a spectrum analyzer or phase noise analyzer. When using most RF test equipment no DC bias point (0 V DC) is expected for safe and proper operation. The internal 50 ohm termination the test equipment correctly terminates the LVPECL driver being measured as shown in Figure 7-10. When using only one LVPECL driver of a CLKoutX/CLKoutX* pair, be sure to properly terminate the unused driver.

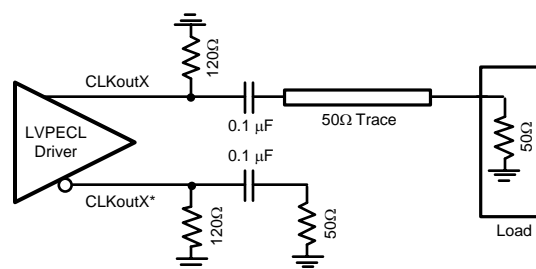

Figure 7-10. Single-Ended LVPECL Operation, AC Coupling

7.7.4 Conversion to LVCMOS Outputs

To drive an LVCMOS input with an LMK03200 family LVDS or LVPECL output, an LVPECL/LVDS to LVCMOS converter such as TI's DS90LV018A, DS90LV028A, DS90LV048A, etc. is required. For best noise performance, LVPECL provides a higher voltage swing into input of the converter.

7.8 OSCin INPUT

In addition to LVDS and LVPECL inputs, OSCin can also be driven with a sine wave. The OSCin input can be driven single-ended or differentially with sine waves. The configurations for these are shown in Figure 7-11 and Figure 7-12.

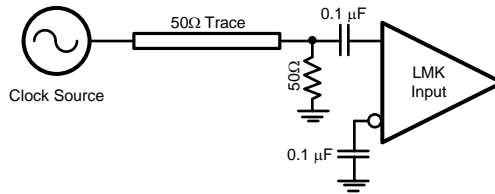

Figure 7-11. Single-Ended Sine Wave Input

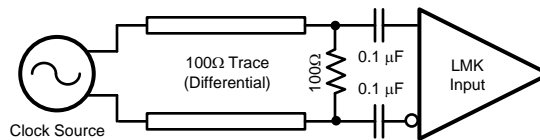

Figure 7-12. Differential Sine Wave Input

Figure 7-13 shows the recommended power level for sine wave operation for both differential and single-ended sources over frequency. The part will operate at power levels below the recommended power level, but as power decreases the PLL noise performance will degrade. The VCO noise performance will remain constant. At the recommended power level the PLL phase noise degradation from full power operation (8 dBm) is less than 2 dB.

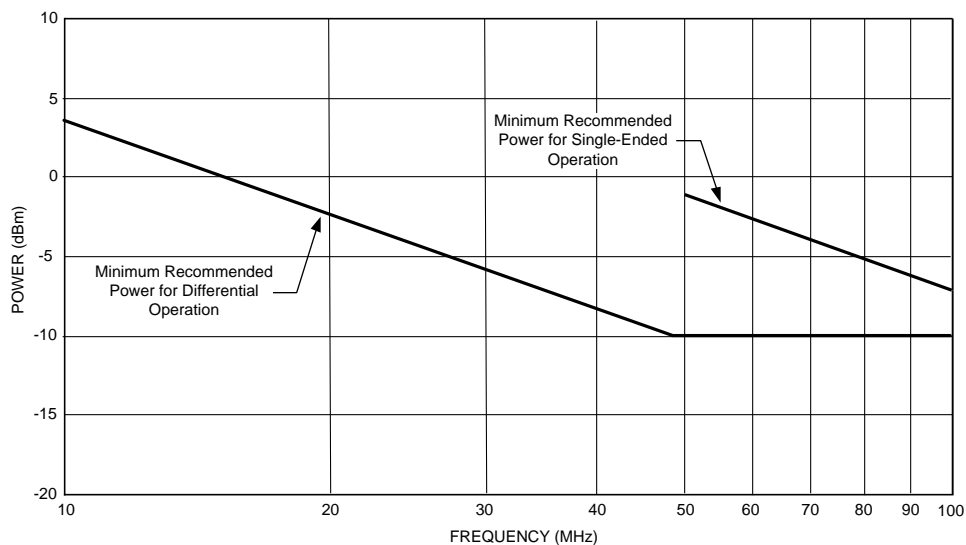

Figure 7-13. Recommended OSCin Power for Operation with a Sine Wave Input

7.9 MORE THAN EIGHT OUTPUTS WITH AN LMK03200 FAMILY DEVICE

The LMK03200 family devices include eight outputs. When more than 8 outputs are required the footprint compatible LMK01000 family may be used for clock distribution. By using an LMK03200 device with eight LMK01000 family devices up to 64 clocks may be distributed in many different LVDS / LVPECL combinations. It's possible to distribute more than 64 clocks by adding more LMK01000 family devices. Refer to AN-1864 (literature number [SNAA060](#)) for more details.

7.10 DIFFERENTIAL VOLTAGE MEASUREMENT TERMINOLOGY

The differential voltage of a differential signal can be described by two different definitions causing confusion when reading datasheets or communicating with other engineers. This section will address the measurement and description of a differential signal so that the reader will be able to understand and discern between the two different definitions when used.

The first definition used to describe a differential signal is the absolute value of the voltage potential between the inverting and non-inverting signal. The symbol for this first measurement is typically V_{ID} or V_{OD} depending on if an input or output voltage is being described.

The second definition used to describe a differential signal is to measure the potential of the non-inverting signal with respect to the inverting signal. The symbol for this second measurement is V_{SS} and is a calculated parameter. Nowhere in the IC does this signal exist with respect to ground, it only exists in reference to its differential pair. V_{SS} can be measured directly by oscilloscopes with floating references, otherwise this value can be calculated as twice the value of V_{OD} as described in the first description.

[Figure 7-14](#) and [Figure 7-15](#) illustrate the two different definitions side-by-side for inputs and outputs respectively. The V_{ID} and V_{OD} definitions show V_A and V_B DC levels that the non-inverting and inverting signals toggle between with respect to ground. V_{SS} input and output definitions show that if the inverting signal is considered the reference, the non-inverting signal voltage potential is now increasing and decreasing above and below the non-inverting reference. Thus the peak-to-peak voltage of the differential signal can be measured. Hence V_{ID} and V_{OD} are often defined as volts (V) and V_{SS} is often defined as volts peak-to-peak (V_{PP}).

Refer to application note *AN-912 Common Data Transmission Parameters and their Definitions* (literature number [SNLA036](#)) for more information.

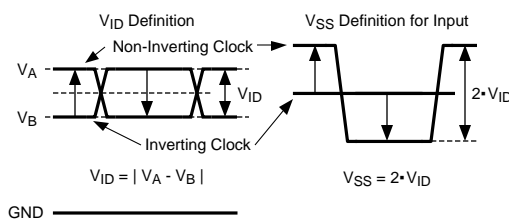

Figure 7-14. Two Different Definitions for Differential Input Signals

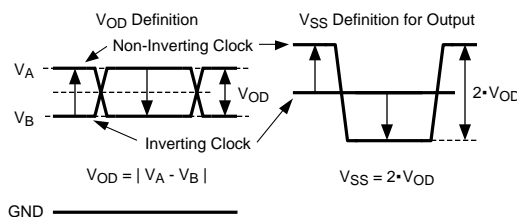

Figure 7-15. Two Different Definitions for Differential Output Signals

Revision History

NOTE: Page numbers for previous revisions may differ from page numbers in the current version.

Changes from Revision B (April 2013) to Revision C Page

- Changed layout of National Data Sheet to TI format [47](#)
-

PACKAGING INFORMATION

Orderable Device	Status (1)	Package Type	Package Drawing	Pins	Package Qty	Eco Plan (2)	Lead/Ball Finish	MSL Peak Temp (3)	Op Temp (°C)	Top-Side Markings (4)	Samples
LMK03200ISQ/NOPB	ACTIVE	WQFN	RHS	48	1000	Green (RoHS & no Sb/Br)	CU SN	Level-3-260C-168 HR	-40 to 85	K03200 I	Samples
LMK03200ISQE/NOPB	ACTIVE	WQFN	RHS	48	250	Green (RoHS & no Sb/Br)	CU SN	Level-3-260C-168 HR	-40 to 85	K03200 I	Samples
LMK03200ISQX/NOPB	ACTIVE	WQFN	RHS	48	2500	Green (RoHS & no Sb/Br)	CU SN	Level-3-260C-168 HR	-40 to 85	K03200 I	Samples

(1) The marketing status values are defined as follows:

ACTIVE: Product device recommended for new designs.

LIFEBUY: TI has announced that the device will be discontinued, and a lifetime-buy period is in effect.

NRND: Not recommended for new designs. Device is in production to support existing customers, but TI does not recommend using this part in a new design.

PREVIEW: Device has been announced but is not in production. Samples may or may not be available.

OBSOLETE: TI has discontinued the production of the device.

(2) Eco Plan - The planned eco-friendly classification: Pb-Free (RoHS), Pb-Free (RoHS Exempt), or Green (RoHS & no Sb/Br) - please check <http://www.ti.com/productcontent> for the latest availability information and additional product content details.

TBD: The Pb-Free/Green conversion plan has not been defined.

Pb-Free (RoHS): TI's terms "Lead-Free" or "Pb-Free" mean semiconductor products that are compatible with the current RoHS requirements for all 6 substances, including the requirement that lead not exceed 0.1% by weight in homogeneous materials. Where designed to be soldered at high temperatures, TI Pb-Free products are suitable for use in specified lead-free processes.

Pb-Free (RoHS Exempt): This component has a RoHS exemption for either 1) lead-based flip-chip solder bumps used between the die and package, or 2) lead-based die adhesive used between the die and leadframe. The component is otherwise considered Pb-Free (RoHS compatible) as defined above.

Green (RoHS & no Sb/Br): TI defines "Green" to mean Pb-Free (RoHS compatible), and free of Bromine (Br) and Antimony (Sb) based flame retardants (Br or Sb do not exceed 0.1% by weight in homogeneous material)

(3) MSL, Peak Temp. -- The Moisture Sensitivity Level rating according to the JEDEC industry standard classifications, and peak solder temperature.

(4) Multiple Top-Side Markings will be inside parentheses. Only one Top-Side Marking contained in parentheses and separated by a "~" will appear on a device. If a line is indented then it is a continuation of the previous line and the two combined represent the entire Top-Side Marking for that device.

Important Information and Disclaimer: The information provided on this page represents TI's knowledge and belief as of the date that it is provided. TI bases its knowledge and belief on information provided by third parties, and makes no representation or warranty as to the accuracy of such information. Efforts are underway to better integrate information from third parties. TI has taken and continues to take reasonable steps to provide representative and accurate information but may not have conducted destructive testing or chemical analysis on incoming materials and chemicals. TI and TI suppliers consider certain information to be proprietary, and thus CAS numbers and other limited information may not be available for release.

In no event shall TI's liability arising out of such information exceed the total purchase price of the TI part(s) at issue in this document sold by TI to Customer on an annual basis.

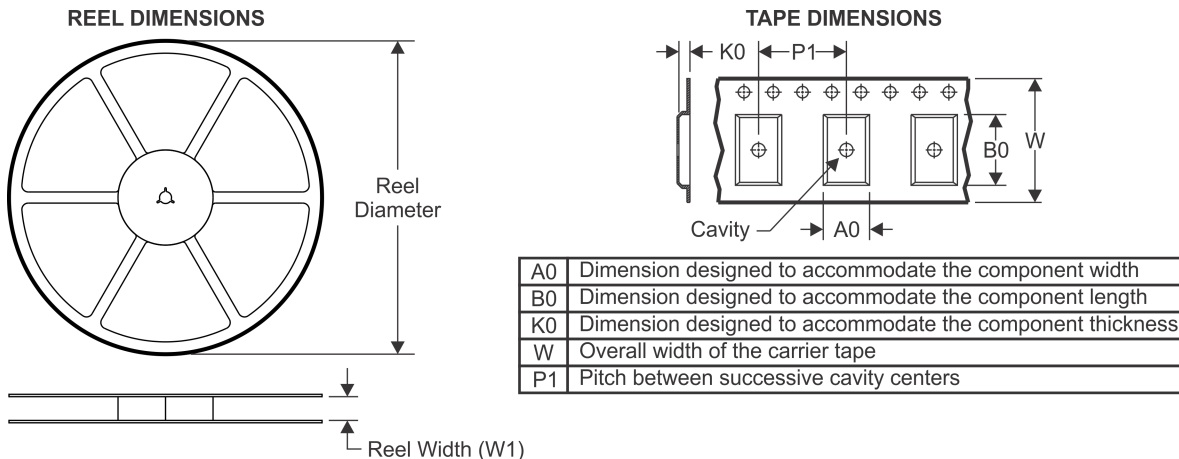
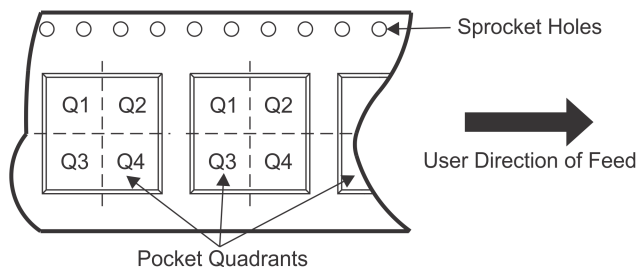
TAPE AND REEL INFORMATION

QUADRANT ASSIGNMENTS FOR PIN 1 ORIENTATION IN TAPE

*All dimensions are nominal

Device	Package Type	Package Drawing	Pins	SPQ	Reel Diameter (mm)	Reel Width W1 (mm)	A0 (mm)	B0 (mm)	K0 (mm)	P1 (mm)	W (mm)	Pin1 Quadrant
LMK03200ISQ/NOPB	WQFN	RHS	48	1000	330.0	16.4	7.3	7.3	1.3	12.0	16.0	Q1
LMK03200ISQE/NOPB	WQFN	RHS	48	250	178.0	16.4	7.3	7.3	1.3	12.0	16.0	Q1
LMK03200ISQX/NOPB	WQFN	RHS	48	2500	330.0	16.4	7.3	7.3	1.3	12.0	16.0	Q1

TAPE AND REEL BOX DIMENSIONS

*All dimensions are nominal

Device	Package Type	Package Drawing	Pins	SPQ	Length (mm)	Width (mm)	Height (mm)
LMK03200ISQ/NOPB	WQFN	RHS	48	1000	367.0	367.0	38.0
LMK03200ISQE/NOPB	WQFN	RHS	48	250	210.0	185.0	35.0
LMK03200ISQX/NOPB	WQFN	RHS	48	2500	367.0	367.0	38.0

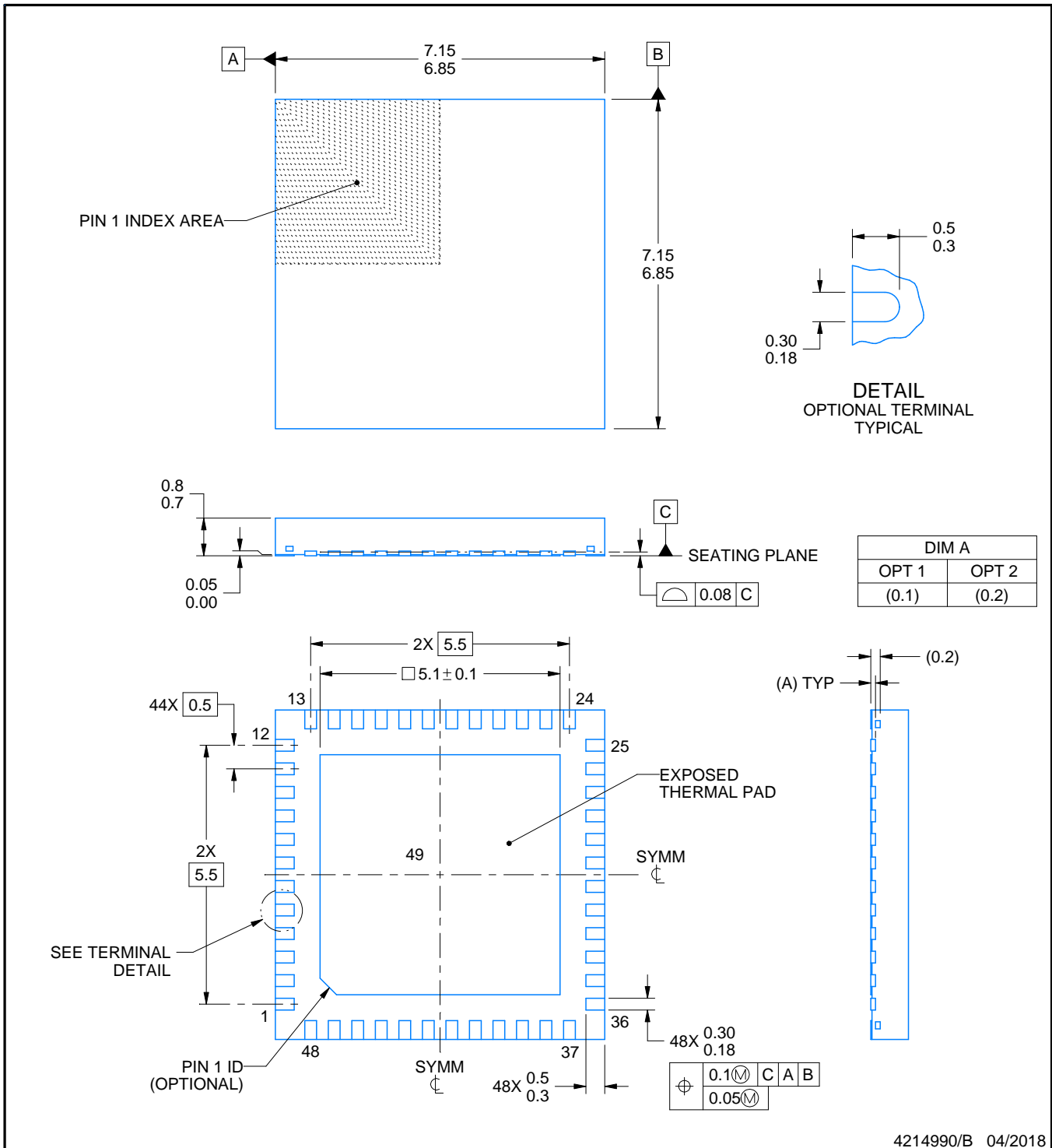
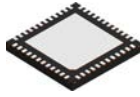

4214990/B 04/2018

NOTES:

1. All linear dimensions are in millimeters. Any dimensions in parenthesis are for reference only. Dimensioning and tolerancing per ASME Y14.5M.
2. This drawing is subject to change without notice.
3. The package thermal pad must be soldered to the printed circuit board for thermal and mechanical performance.

EXAMPLE STENCIL DESIGN

RHS0048A

WQFN - 0.8 mm max height

PLASTIC QUAD FLATPACK - NO LEAD

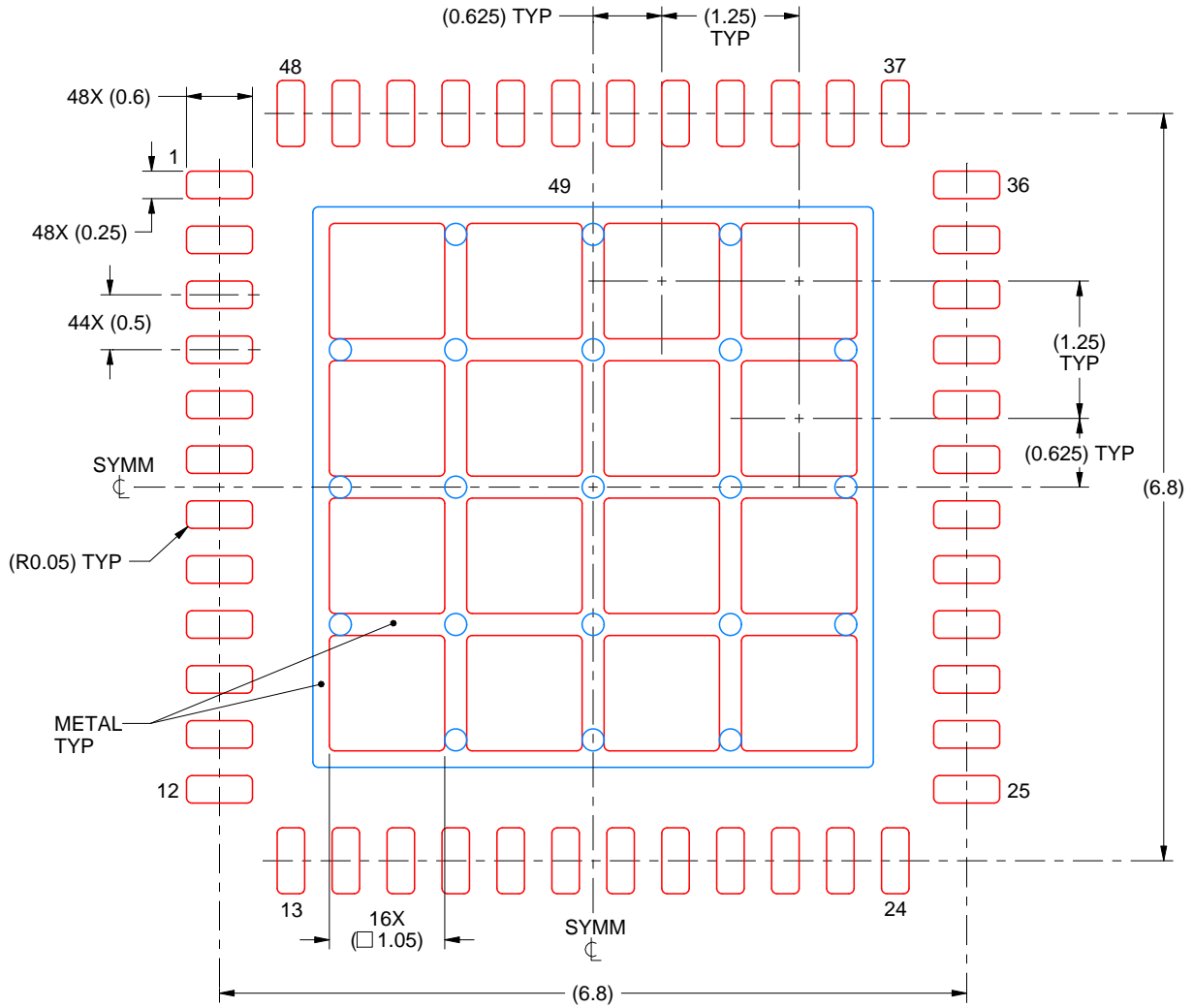

SOLDER PASTE EXAMPLE
BASED ON 0.125 mm THICK STENCIL

EXPOSED PAD 49
68% PRINTED SOLDER COVERAGE BY AREA UNDER PACKAGE
SCALE:15X

4214990/B 04/2018

NOTES: (continued)

6. Laser cutting apertures with trapezoidal walls and rounded corners may offer better paste release. IPC-7525 may have alternate design recommendations.

IMPORTANT NOTICE

Texas Instruments Incorporated (TI) reserves the right to make corrections, enhancements, improvements and other changes to its semiconductor products and services per JESD46, latest issue, and to discontinue any product or service per JESD48, latest issue. Buyers should obtain the latest relevant information before placing orders and should verify that such information is current and complete.

TI's published terms of sale for semiconductor products (<http://www.ti.com/sc/docs/stdterms.htm>) apply to the sale of packaged integrated circuit products that TI has qualified and released to market. Additional terms may apply to the use or sale of other types of TI products and services.

Reproduction of significant portions of TI information in TI data sheets is permissible only if reproduction is without alteration and is accompanied by all associated warranties, conditions, limitations, and notices. TI is not responsible or liable for such reproduced documentation. Information of third parties may be subject to additional restrictions. Resale of TI products or services with statements different from or beyond the parameters stated by TI for that product or service voids all express and any implied warranties for the associated TI product or service and is an unfair and deceptive business practice. TI is not responsible or liable for any such statements.

Buyers and others who are developing systems that incorporate TI products (collectively, "Designers") understand and agree that Designers remain responsible for using their independent analysis, evaluation and judgment in designing their applications and that Designers have full and exclusive responsibility to assure the safety of Designers' applications and compliance of their applications (and of all TI products used in or for Designers' applications) with all applicable regulations, laws and other applicable requirements. Designer represents that, with respect to their applications, Designer has all the necessary expertise to create and implement safeguards that (1) anticipate dangerous consequences of failures, (2) monitor failures and their consequences, and (3) lessen the likelihood of failures that might cause harm and take appropriate actions. Designer agrees that prior to using or distributing any applications that include TI products, Designer will thoroughly test such applications and the functionality of such TI products as used in such applications.

TI's provision of technical, application or other design advice, quality characterization, reliability data or other services or information, including, but not limited to, reference designs and materials relating to evaluation modules, (collectively, "TI Resources") are intended to assist designers who are developing applications that incorporate TI products; by downloading, accessing or using TI Resources in any way, Designer (individually or, if Designer is acting on behalf of a company, Designer's company) agrees to use any particular TI Resource solely for this purpose and subject to the terms of this Notice.

TI's provision of TI Resources does not expand or otherwise alter TI's applicable published warranties or warranty disclaimers for TI products, and no additional obligations or liabilities arise from TI providing such TI Resources. TI reserves the right to make corrections, enhancements, improvements and other changes to its TI Resources. TI has not conducted any testing other than that specifically described in the published documentation for a particular TI Resource.

Designer is authorized to use, copy and modify any individual TI Resource only in connection with the development of applications that include the TI product(s) identified in such TI Resource. NO OTHER LICENSE, EXPRESS OR IMPLIED, BY ESTOPPEL OR OTHERWISE TO ANY OTHER TI INTELLECTUAL PROPERTY RIGHT, AND NO LICENSE TO ANY TECHNOLOGY OR INTELLECTUAL PROPERTY RIGHT OF TI OR ANY THIRD PARTY IS GRANTED HEREIN, including but not limited to any patent right, copyright, mask work right, or other intellectual property right relating to any combination, machine, or process in which TI products or services are used. Information regarding or referencing third-party products or services does not constitute a license to use such products or services, or a warranty or endorsement thereof. Use of TI Resources may require a license from a third party under the patents or other intellectual property of the third party, or a license from TI under the patents or other intellectual property of TI.

TI RESOURCES ARE PROVIDED "AS IS" AND WITH ALL FAULTS. TI DISCLAIMS ALL OTHER WARRANTIES OR REPRESENTATIONS, EXPRESS OR IMPLIED, REGARDING RESOURCES OR USE THEREOF, INCLUDING BUT NOT LIMITED TO ACCURACY OR COMPLETENESS, TITLE, ANY EPIDEMIC FAILURE WARRANTY AND ANY IMPLIED WARRANTIES OF MERCHANTABILITY, FITNESS FOR A PARTICULAR PURPOSE, AND NON-INFRINGEMENT OF ANY THIRD PARTY INTELLECTUAL PROPERTY RIGHTS. TI SHALL NOT BE LIABLE FOR AND SHALL NOT DEFEND OR INDEMNIFY DESIGNER AGAINST ANY CLAIM, INCLUDING BUT NOT LIMITED TO ANY INFRINGEMENT CLAIM THAT RELATES TO OR IS BASED ON ANY COMBINATION OF PRODUCTS EVEN IF DESCRIBED IN TI RESOURCES OR OTHERWISE. IN NO EVENT SHALL TI BE LIABLE FOR ANY ACTUAL, DIRECT, SPECIAL, COLLATERAL, INDIRECT, PUNITIVE, INCIDENTAL, CONSEQUENTIAL OR EXEMPLARY DAMAGES IN CONNECTION WITH OR ARISING OUT OF TI RESOURCES OR USE THEREOF, AND REGARDLESS OF WHETHER TI HAS BEEN ADVISED OF THE POSSIBILITY OF SUCH DAMAGES.

Unless TI has explicitly designated an individual product as meeting the requirements of a particular industry standard (e.g., ISO/TS 16949 and ISO 26262), TI is not responsible for any failure to meet such industry standard requirements.

Where TI specifically promotes products as facilitating functional safety or as compliant with industry functional safety standards, such products are intended to help enable customers to design and create their own applications that meet applicable functional safety standards and requirements. Using products in an application does not by itself establish any safety features in the application. Designers must ensure compliance with safety-related requirements and standards applicable to their applications. Designer may not use any TI products in life-critical medical equipment unless authorized officers of the parties have executed a special contract specifically governing such use. Life-critical medical equipment is medical equipment where failure of such equipment would cause serious bodily injury or death (e.g., life support, pacemakers, defibrillators, heart pumps, neurostimulators, and implantables). Such equipment includes, without limitation, all medical devices identified by the U.S. Food and Drug Administration as Class III devices and equivalent classifications outside the U.S.

TI may expressly designate certain products as completing a particular qualification (e.g., Q100, Military Grade, or Enhanced Product). Designers agree that it has the necessary expertise to select the product with the appropriate qualification designation for their applications and that proper product selection is at Designers' own risk. Designers are solely responsible for compliance with all legal and regulatory requirements in connection with such selection.

Designer will fully indemnify TI and its representatives against any damages, costs, losses, and/or liabilities arising out of Designer's non-compliance with the terms and provisions of this Notice.

Looking for pricing, stock, or lifecycle information?

Click below to explore more details on WIN SOURCE:

 [View LMK03200ISQE/NOPB on WIN SOURCE](#)

 [Texas Instruments](#) Information

Optimize Your Supply Chain with WIN SOURCE Solutions

-  Global Sourcing Solution
-  Obsolete Management
-  Cost Control Management
-  Shortage Management
-  Alternative Solution
-  Excess Inventory Management