



**THE DATASHEET OF
SN65EL16DGK**



5-V ECL Differential Receiver

FEATURES

- Differential PECL/NECL Receiver
- Operating Range
 - PECL: $V_{CC} = 4.2\text{ V to }5.7\text{ V}$ With $V_{EE} = 0\text{ V}$
 - NECL: $V_{CC} = 0\text{ V}$ With $V_{EE} = -4.2\text{ V to }-5.7\text{ V}$
- 250-ps Propagation Delay
- Support for Clock Frequencies >2 GHz
- Deterministic Output Value for Open Input Conditions
- Built-In Temperature Compensation
- Drop-In Compatible With MC10EL16, MC100EL16
- Built-In Input Pulldown Resistors

APPLICATIONS

- Data and Clock Transmission Over Backplane

DESCRIPTION

The SN65EL16 is a differential PECL/ECL receiver with PECL/ECL output. The device includes circuitry to hold Q to a low logic level when the inputs are in an open condition.

The V_{BB} pin is a reference voltage output for the device. When the device is used in the single-ended mode, the unused input should be tied to V_{BB} . This reference voltage can also be used to bias the input when it is ac coupled. When the V_{BB} pin is used, place a 0.01- μF decoupling capacitor between V_{CC} and V_{BB} . Also, limit the sink/source current to <0.5 mA to V_{BB} . Leave V_{BB} open when it is not used.

The SN65EL11 is housed in an industry-standard SOIC-8 package and is also available in a TSSOP-8 package.

PINOUT ASSIGNMENT

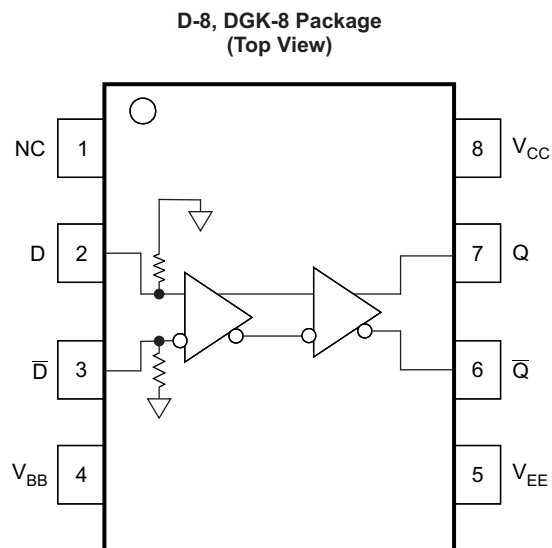

P0065-03

Table 1. Pin Description

PIN	FUNCTION
D, \bar{D}	PECL/ECL data inputs
Q, \bar{Q}	PECL/ECL outputs
V_{CC}	Positive supply
V_{EE}	Negative supply
V_{BB}	Reference voltage output

ORDERING INFORMATION⁽¹⁾

PART NUMBER	PART MARKING	PACKAGE	LEAD FINISH
SN65EL16D	SN65EL16	SOIC	NiPdAu
SN65EL16DGK	SN65EL16	SOIC-TSSOP	NiPdAu

(1) Leaded device options not initially available; contact a sales representative for further details.



Please be aware that an important notice concerning availability, standard warranty, and use in critical applications of Texas Instruments semiconductor products and disclaimers thereto appears at the end of this data sheet.



These devices have limited built-in ESD protection. The leads should be shorted together or the device placed in conductive foam during storage or handling to prevent electrostatic damage to the MOS gates.

ABSOLUTE MAXIMUM RATINGS⁽¹⁾

PARAMETER	CONDITIONS	VALUE	UNIT
Absolute PECL-mode supply voltage, V_{CC}	$V_{EE} = 0\text{ V}$	6	V
Absolute NECL-mode supply voltage, V_{EE}	$V_{CC} = 0\text{ V}$	–6	V
Sink/source current, V_{BB}		± 0.5	mA
PECL-mode input voltage	$V_{EE} = 0\text{ V}; V_I \leq V_{CC}$	6	V
NECL-mode input voltage	$V_{CC} = 0\text{ V}; V_I \geq V_{EE}$	–6	V
Output current	Continuous	50	mA
	Surge	100	mA
Operating temperature range		–40 to 85	°C
Storage temperature range		–65 to 150	°C

(1) Stresses beyond those listed under absolute maximum ratings may cause permanent damage to the device. These are stress ratings only and functional operation of the device at these or any conditions beyond those indicated under recommended operating conditions is not implied. Exposure to absolute-maximum-rated conditions for extended periods may affect device reliability.

POWER DISSIPATION RATINGS

PACKAGE	CIRCUIT-BOARD MODEL	POWER RATING $T_A < 25^\circ\text{C}$ (mW)	THERMAL RESISTANCE, JUNCTION-TO-AMBIENT, NO AIRFLOW	DERATING FACTOR $T_A > 25^\circ\text{C}$ (mW/°C)	POWER RATING $T_A = 85^\circ\text{C}$ (mW)
SOIC	Low-K	719	139	7	288
	High-K	840	119	8	336
SOIC-TSSOP	Low-K	469	213	5	188
	High-K	527	189	5	211

THERMAL CHARACTERISTICS

PARAMETER		PACKAGE	VALUE	UNIT
θ_{JB}	Junction-to-board thermal resistance	SOIC	79	°C/W
		SOIC-TSSOP	120	
θ_{JC}	Junction-to-case thermal resistance	SOIC	98	°C/W
		SOIC-TSSOP	74	

KEY ATTRIBUTES

CHARACTERISTICS	VALUE
Internal input pulldown resistor	75 k Ω
Moisture sensitivity level	Level 1
Flammability rating (oxygen index: 28 to 34)	UL 94 V-0 at 0.125 in
ESD—human-body model	4 kV
ESD—machine model	200 V
ESD—charged-device model	2 kV
Meets or exceeds JEDEC Spec EIA/JESD78 latchup test	

PECL DC CHARACTERISTICS⁽¹⁾ ($V_{CC} = 5\text{ V}$; $V_{EE} = 0\text{ V}$)⁽²⁾

PARAMETER	–40°C			25°C			85°C			UNIT
	MIN	TYP	MAX	MIN	TYP	MAX	MIN	TYP	MAX	
I_{EE} Power-supply current		15	20		15	20		19	23	mA
V_{OH} Output HIGH voltage ⁽³⁾	3915		4120	3915	4011	4120	3915		4120	mV
V_{OL} Output LOW voltage ⁽³⁾	3170		3380	3170	3252	3380	3170		3380	mV
V_{IH} Input HIGH voltage (single-ended)	3835		4120	3835		4120	3835		4120	mV
V_{IL} Input LOW voltage (single-ended)	3190		3525	3190		3525	3190		3525	mV
V_{BB} Output reference voltage	3.62		3.74	3.62		3.74	3.62		3.74	V
V_{IHCMR} Input HIGH voltage, common-mode range (differential) ⁽⁴⁾	2.5		4.6	2.5		4.6	2.5		4.6	V
I_{IH} Input HIGH current			150		60	150			150	μA
I_{IL} Input LOW current	0.5			0.5	64		0.5			μA

- (1) The device meets the specifications after thermal balance has been established when mounted in a socket or printed-circuit board with maintained transverse airflow greater than 500 lpm (2.54 m/s). Electrical parameters are assured only over the declared operating temperature range. Functional operation of the device exceeding these conditions is not implied. Device specification limit values are applied individually under normal operating conditions and are not valid simultaneously.
- (2) Input and output parameters vary 1:1 with V_{CC} . V_{EE} can vary +0.8 V /–0.5 V.
- (3) Outputs are terminated through a 50-Ω resistor to $V_{CC} - 2\text{ V}$.
- (4) V_{IHCMR} min varies 1:1 with V_{EE} ; V_{IHCMR} max varies 1:1 with V_{CC} . The V_{IHCMR} range is referenced to the more-positive side of the differential input signal. Normal operation is obtained if the HIGH level falls within the specified range and the peak-to-peak voltage lies between V_{PP} min and 1 V.

NECL DC CHARACTERISTICS⁽¹⁾ ($V_{CC} = 0\text{ V}$; $V_{EE} = 5\text{ V}$)⁽²⁾

PARAMETER	–40°C			25°C			85°C			UNIT
	MIN	TYP	MAX	MIN	TYP	MAX	MIN	TYP	MAX	
I_{EE} Power-supply current		15	20		15	20		19	23	mA
V_{OH} Output HIGH voltage ⁽³⁾	–1085		–880	–1085	–988	–880	–1085		–880	mV
V_{OL} Output LOW voltage ⁽³⁾	–1830		–1620	–1830	–1747	–1620	–1830		–1620	mV
V_{IH} Input HIGH voltage (single-ended)	–1165		–880	–1165		–880	–1165		–880	mV
V_{IL} Input LOW voltage (single-ended)	–1810		–1475	–1810		–1475	–1810		–1475	mV
V_{BB} Output reference voltage	–1.38		–1.26	–1.38		–1.26	–1.38		–1.26	V
V_{IHCMR} Input HIGH voltage, common-mode range (differential) ⁽⁴⁾	–2.5		–0.4	–2.5		–0.4	–2.5		–0.4	V
I_{IH} Input HIGH current			150			150			150	μA
I_{IL} Input LOW current	0.5			0.5			0.5			μA

- (1) The device meets the specifications after thermal balance has been established when mounted in a socket or printed-circuit board with maintained transverse airflow greater than 500 lpm (2.54 m/s). Electrical parameters are assured only over the declared operating temperature range. Functional operation of the device exceeding these conditions is not implied. Device specification limit values are applied individually under normal operating conditions and are not valid simultaneously.
- (2) Input and output parameters vary 1:1 with V_{CC} . V_{EE} can vary +0.8 V /–0.5 V.
- (3) Outputs are terminated through a 50-Ω resistor to $V_{CC} - 2\text{ V}$.
- (4) V_{IHCMR} min varies 1:1 with V_{EE} ; V_{IHCMR} max varies 1:1 with V_{CC} . The V_{IHCMR} range is referenced to the more-positive side of the differential input signal. Normal operation is obtained if the HIGH level falls within the specified range and the peak-to-peak voltage lies between V_{PP} min and 1 V.

AC CHARACTERISTICS⁽¹⁾ ($V_{CC} = 5\text{ V}$; $V_{EE} = 0\text{ V}$ or $V_{CC} = 0\text{ V}$; $V_{EE} = -5\text{ V}$)⁽²⁾

PARAMETER		-40°C			25°C			85°C			UNIT			
		MIN	TYP	MAX	MIN	TYP	MAX	MIN	TYP	MAX				
f_{MAX}	Maximum switching frequency ⁽³⁾ (see Figure 6)	3.5			3.5			3.4			GHz			
t_{PLH}/t_{PHL}	Propagation delay to output	Diff mode (see Figure 3)		200	300		200	300		200	300		ps	
		SE mode (see Figure 2)		75						405				
t_{SKEW}	Duty cycle skew ⁽⁴⁾	5			20			5			20			ps
t_{JITTER}	Random clock jitter (RMS)	0.2			0.2			0.2						ps
V_{PP}	Input swing ⁽⁵⁾ (see Figure 4)	150			1000			150			1000			mV
t_r/t_f	Output rise/fall times Q (20%–80%) (see Figure 5)	100			250			100			250			ps

- (1) The device meets these specifications after thermal equilibrium has been established when mounted in a test socket or printed-circuit board with maintained transverse airflow greater than 500 lfm (2.54 m/s). Electrical parameters are assured only over the declared operating temperature range. Functional operation of the device exceeding these conditions is not implied. Device specification limit values are applied individually under normal operating conditions and are not valid simultaneously.
- (2) Input and output parameters vary 1:1 with V_{CC} . V_{EE} can vary +0.8 V / -0.5 V.
- (3) Maximum switching frequency is measured at an output amplitude of 300 mV.
- (4) Duty-cycle skew is the difference between a t_{PLH} and t_{PHL} propagation delay through a device.
- (5) $V_{PP(min)}$ is the minimum input swing for which ac parameters assured.

Typical Termination for Output Driver

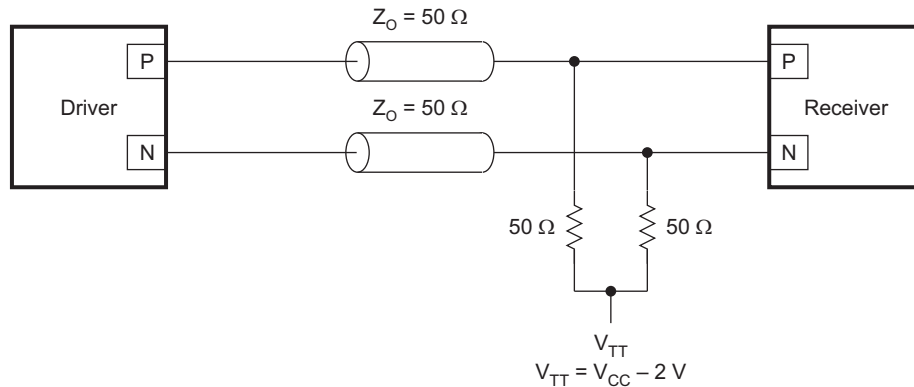

S0078-02

Figure 1. Typical Termination for Output Driver

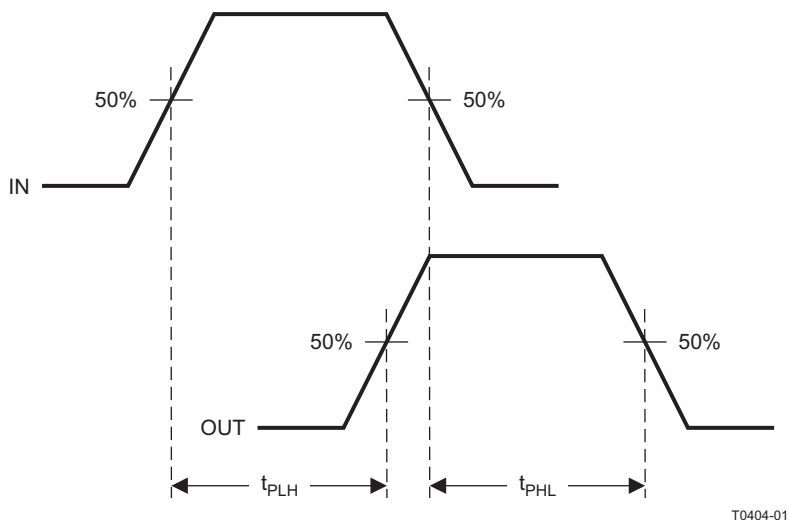

Figure 2. Single-Ended Propagation Delay

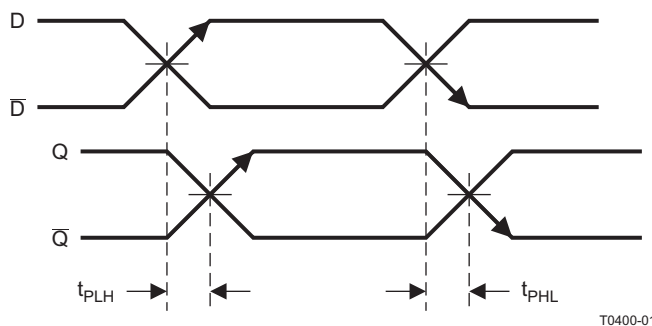

Figure 3. Differential Propagation Delay

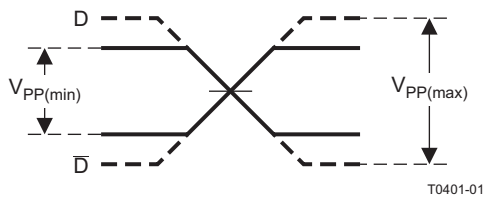

Figure 4. Input Voltage Swing

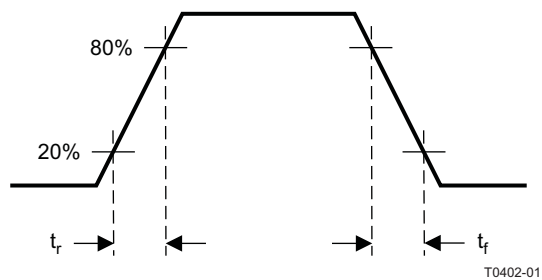

Figure 5. Output Rise and Fall Times

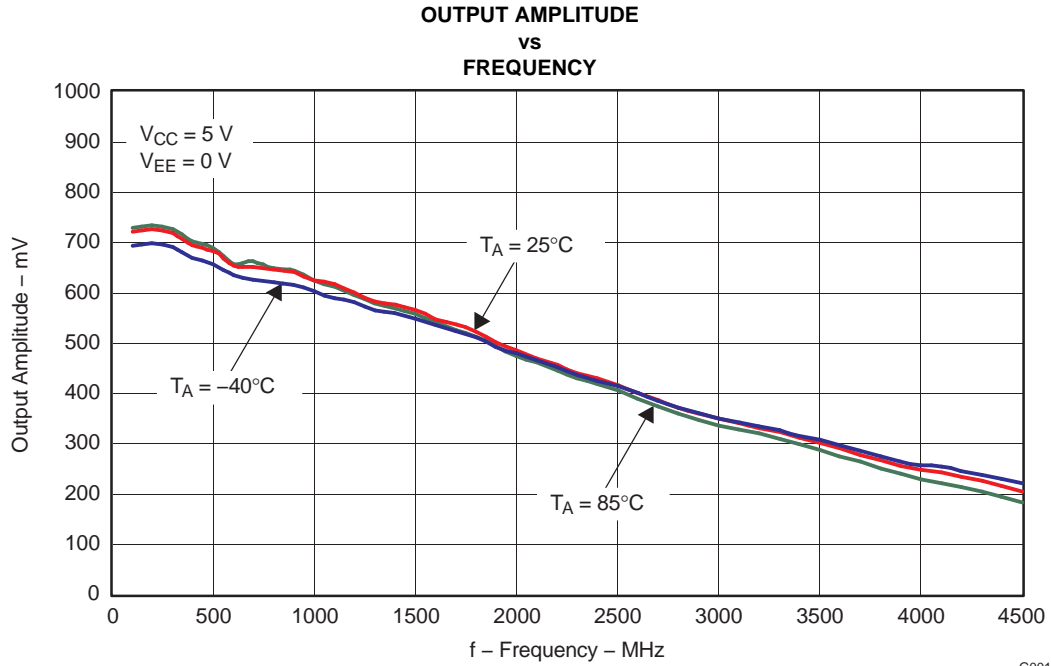

Figure 6.

PACKAGING INFORMATION

Orderable Device	Status (1)	Package Type	Package Drawing	Pins	Package Qty	Eco Plan (2)	Lead/Ball Finish (6)	MSL Peak Temp (3)	Op Temp (°C)	Device Marking (4/5)	Samples
SN65EL16D	ACTIVE	SOIC	D	8	75	Green (RoHS & no Sb/Br)	CU NIPDAU	Level-1-260C-UNLIM	-40 to 85	EL16	Samples
SN65EL16DGK	ACTIVE	VSSOP	DGK	8	80	Green (RoHS & no Sb/Br)	CU NIPDAU	Level-1-260C-UNLIM	-40 to 85	SIOI	Samples
SN65EL16DGKR	ACTIVE	VSSOP	DGK	8	2500	Green (RoHS & no Sb/Br)	CU NIPDAU	Level-1-260C-UNLIM	-40 to 85	SIOI	Samples

(1) The marketing status values are defined as follows:

ACTIVE: Product device recommended for new designs.

LIFEBUY: TI has announced that the device will be discontinued, and a lifetime-buy period is in effect.

NRND: Not recommended for new designs. Device is in production to support existing customers, but TI does not recommend using this part in a new design.

PREVIEW: Device has been announced but is not in production. Samples may or may not be available.

OBsolete: TI has discontinued the production of the device.

(2) Eco Plan - The planned eco-friendly classification: Pb-Free (RoHS), Pb-Free (RoHS Exempt), or Green (RoHS & no Sb/Br) - please check <http://www.ti.com/productcontent> for the latest availability information and additional product content details.

TBD: The Pb-Free/Green conversion plan has not been defined.

Pb-Free (RoHS): TI's terms "Lead-Free" or "Pb-Free" mean semiconductor products that are compatible with the current RoHS requirements for all 6 substances, including the requirement that lead not exceed 0.1% by weight in homogeneous materials. Where designed to be soldered at high temperatures, TI Pb-Free products are suitable for use in specified lead-free processes.

Pb-Free (RoHS Exempt): This component has a RoHS exemption for either 1) lead-based flip-chip solder bumps used between the die and package, or 2) lead-based die adhesive used between the die and leadframe. The component is otherwise considered Pb-Free (RoHS compatible) as defined above.

Green (RoHS & no Sb/Br): TI defines "Green" to mean Pb-Free (RoHS compatible), and free of Bromine (Br) and Antimony (Sb) based flame retardants (Br or Sb do not exceed 0.1% by weight in homogeneous material)

(3) MSL, Peak Temp. - The Moisture Sensitivity Level rating according to the JEDEC industry standard classifications, and peak solder temperature.

(4) There may be additional marking, which relates to the logo, the lot trace code information, or the environmental category on the device.

(5) Multiple Device Markings will be inside parentheses. Only one Device Marking contained in parentheses and separated by a "~" will appear on a device. If a line is indented then it is a continuation of the previous line and the two combined represent the entire Device Marking for that device.

(6) Lead/Ball Finish - Orderable Devices may have multiple material finish options. Finish options are separated by a vertical ruled line. Lead/Ball Finish values may wrap to two lines if the finish value exceeds the maximum column width.

Important Information and Disclaimer: The information provided on this page represents TI's knowledge and belief as of the date that it is provided. TI bases its knowledge and belief on information provided by third parties, and makes no representation or warranty as to the accuracy of such information. Efforts are underway to better integrate information from third parties. TI has taken and

continues to take reasonable steps to provide representative and accurate information but may not have conducted destructive testing or chemical analysis on incoming materials and chemicals. TI and TI suppliers consider certain information to be proprietary, and thus CAS numbers and other limited information may not be available for release.

In no event shall TI's liability arising out of such information exceed the total purchase price of the TI part(s) at issue in this document sold by TI to Customer on an annual basis.

TAPE AND REEL INFORMATION

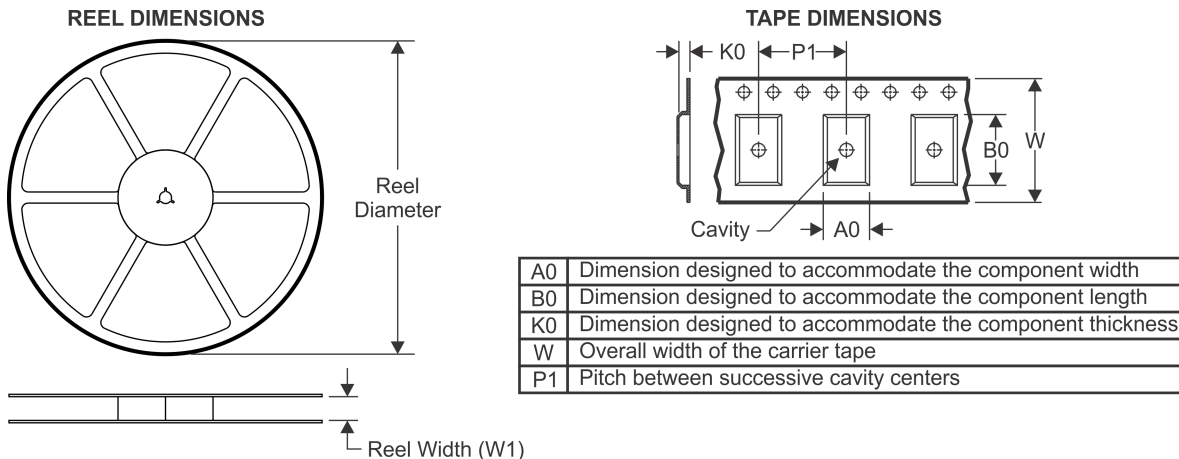

QUADRANT ASSIGNMENTS FOR PIN 1 ORIENTATION IN TAPE



*All dimensions are nominal

Device	Package Type	Package Drawing	Pins	SPQ	Reel Diameter (mm)	Reel Width W1 (mm)	A0 (mm)	B0 (mm)	K0 (mm)	P1 (mm)	W (mm)	Pin1 Quadrant
SN65EL16DGKR	VSSOP	DGK	8	2500	330.0	12.4	5.3	3.4	1.4	8.0	12.0	Q1

TAPE AND REEL BOX DIMENSIONS



*All dimensions are nominal

Device	Package Type	Package Drawing	Pins	SPQ	Length (mm)	Width (mm)	Height (mm)
SN65EL16DGKR	VSSOP	DGK	8	2500	367.0	367.0	35.0



D0008A

PACKAGE OUTLINE

SOIC - 1.75 mm max height

SMALL OUTLINE INTEGRATED CIRCUIT



4214825/C 02/2019

NOTES:

1. Linear dimensions are in inches [millimeters]. Dimensions in parenthesis are for reference only. Controlling dimensions are in inches. Dimensioning and tolerancing per ASME Y14.5M.
2. This drawing is subject to change without notice.
3. This dimension does not include mold flash, protrusions, or gate burrs. Mold flash, protrusions, or gate burrs shall not exceed $.006$ [0.15] per side.
4. This dimension does not include interlead flash.
5. Reference JEDEC registration MS-012, variation AA.

EXAMPLE BOARD LAYOUT

D0008A

SOIC - 1.75 mm max height

SMALL OUTLINE INTEGRATED CIRCUIT



LAND PATTERN EXAMPLE
 EXPOSED METAL SHOWN
 SCALE:8X



SOLDER MASK DETAILS

4214825/C 02/2019

NOTES: (continued)

- 6. Publication IPC-7351 may have alternate designs.
- 7. Solder mask tolerances between and around signal pads can vary based on board fabrication site.

EXAMPLE STENCIL DESIGN

D0008A

SOIC - 1.75 mm max height

SMALL OUTLINE INTEGRATED CIRCUIT



SOLDER PASTE EXAMPLE
BASED ON .005 INCH [0.125 MM] THICK STENCIL
SCALE:8X

4214825/C 02/2019

NOTES: (continued)

8. Laser cutting apertures with trapezoidal walls and rounded corners may offer better paste release. IPC-7525 may have alternate design recommendations.
9. Board assembly site may have different recommendations for stencil design.

DGK (S-PDSO-G8)

PLASTIC SMALL-OUTLINE PACKAGE

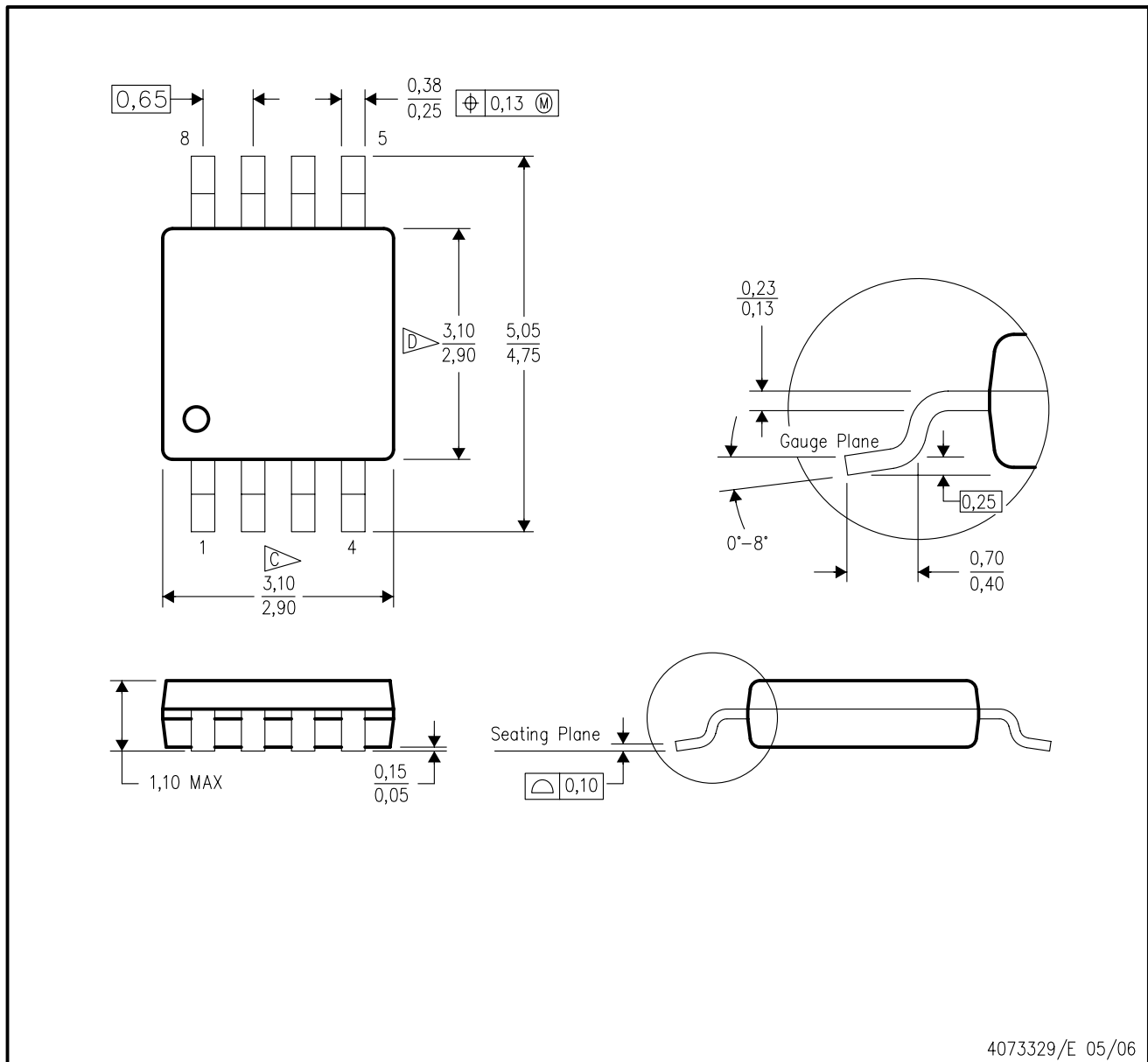

- NOTES:
- A. All linear dimensions are in millimeters.
 - B. This drawing is subject to change without notice.
 - C. Body length does not include mold flash, protrusions, or gate burrs. Mold flash, protrusions, or gate burrs shall not exceed 0.15 per end.
 - D. Body width does not include interlead flash. Interlead flash shall not exceed 0.50 per side.
 - E. Falls within JEDEC MO-187 variation AA, except interlead flash.

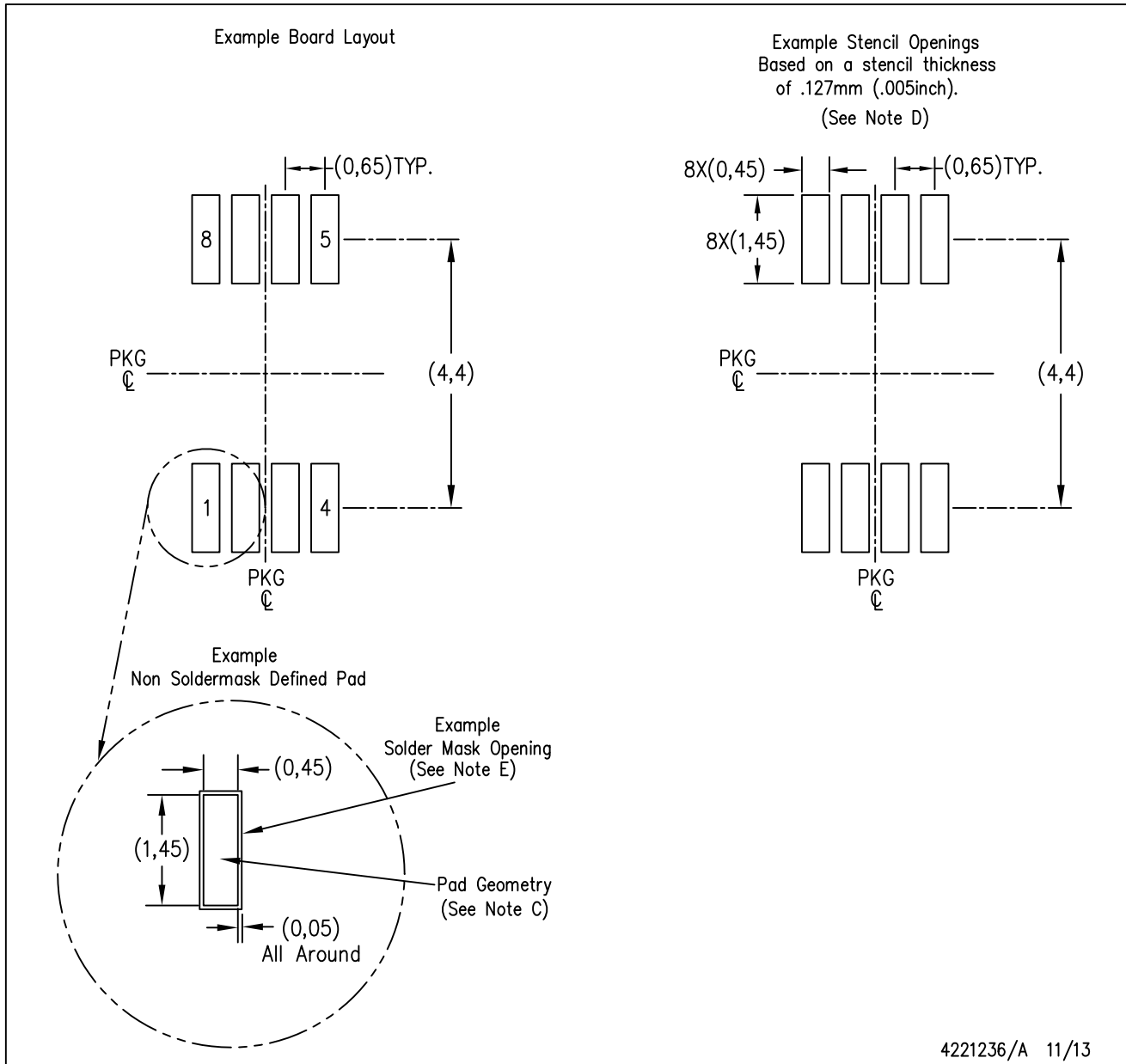

- NOTES:
- A. All linear dimensions are in millimeters.
 - B. This drawing is subject to change without notice.
 - C. Publication IPC-7351 is recommended for alternate designs.
 - D. Laser cutting apertures with trapezoidal walls and also rounding corners will offer better paste release. Customers should contact their board assembly site for stencil design recommendations. Refer to IPC-7525 for other stencil recommendations.
 - E. Customers should contact their board fabrication site for solder mask tolerances between and around signal pads.

IMPORTANT NOTICE AND DISCLAIMER

TI PROVIDES TECHNICAL AND RELIABILITY DATA (INCLUDING DATASHEETS), DESIGN RESOURCES (INCLUDING REFERENCE DESIGNS), APPLICATION OR OTHER DESIGN ADVICE, WEB TOOLS, SAFETY INFORMATION, AND OTHER RESOURCES "AS IS" AND WITH ALL FAULTS, AND DISCLAIMS ALL WARRANTIES, EXPRESS AND IMPLIED, INCLUDING WITHOUT LIMITATION ANY IMPLIED WARRANTIES OF MERCHANTABILITY, FITNESS FOR A PARTICULAR PURPOSE OR NON-INFRINGEMENT OF THIRD PARTY INTELLECTUAL PROPERTY RIGHTS.

These resources are intended for skilled developers designing with TI products. You are solely responsible for (1) selecting the appropriate TI products for your application, (2) designing, validating and testing your application, and (3) ensuring your application meets applicable standards, and any other safety, security, or other requirements. These resources are subject to change without notice. TI grants you permission to use these resources only for development of an application that uses the TI products described in the resource. Other reproduction and display of these resources is prohibited. No license is granted to any other TI intellectual property right or to any third party intellectual property right. TI disclaims responsibility for, and you will fully indemnify TI and its representatives against, any claims, damages, costs, losses, and liabilities arising out of your use of these resources.

TI's products are provided subject to TI's Terms of Sale (www.ti.com/legal/termsofsale.html) or other applicable terms available either on ti.com or provided in conjunction with such TI products. TI's provision of these resources does not expand or otherwise alter TI's applicable warranties or warranty disclaimers for TI products.

Mailing Address: Texas Instruments, Post Office Box 655303, Dallas, Texas 75265
Copyright © 2019, Texas Instruments Incorporated

Looking for pricing, stock, or lifecycle information?

Click below to explore more details on WIN SOURCE:

 [View SN65EL16DGK on WIN SOURCE](#)

 [Texas Instruments](#) Information

Optimize Your Supply Chain with WIN SOURCE Solutions

-  Global Sourcing Solution
-  Obsolete Management
-  Cost Control Management
-  Shortage Management
-  Alternative Solution
-  Excess Inventory Management