



**THE DATASHEET OF
AT25HP512-10PI-2.7**



Features

- Serial Peripheral Interface (SPI) Compatible
- Supports SPI Modes 0 (0,0) and 3 (1,1)
- 128-byte Page Mode Only for Write Operations
- Low-voltage and Standard-voltage Operation
 - 2.7 ($V_{CC} = 2.7V$ to 5.5V)
 - 1.8 ($V_{CC} = 1.8V$ to 5.5V)
- 10 MHz (5V), 5MHz (2.7V) and 2 MHz (1.8V) Clock Rate
- Block Write Protection
- Protect 1/4, 1/2, or Entire Array
- Write Protect (WP) Pin and Write Disable Instructions for both Hardware and Software Data Protection
- High Reliability
 - Endurance: 100K Write Cycles
 - Data Retention: >40 Years
- 8-lead PDIP, 8-lead EIAJ SOIC, 16-lead JEDEC SOIC, 8-lead Leadless Array Package, and 8-lead SOIC Array Package (SAP)
- Die Sales: Wafer Form, Waffle Pack, and Bumped Wafers

Description

The AT25HP256/512 provides 262,144/524,288 bits of serial electrically erasable programmable read only memory (EEPROM) organized as 32,768/65,536 words of 8-bits each. The device is optimized for use in many industrial and commercial applications where high-speed, low-power, and low-voltage operation are essential. The AT25HP256/512 is available in a space saving 8-lead PDIP (AT25HP256/512), 8-lead EIAJ SOIC (AT25HP256), 16-lead JEDEC SOIC (AT25HP512), 8-lead Leadless Array (AT25HP256/512) package, and 8-lead SOIC Array package (SAP). In addition, the entire family is available in 2.7V (2.7V to 5.5V) and 1.8V (1.8V to 5.5V) versions.

Table 1. Pin Configurations

Pin Name	Function
\overline{CS}	Chip Select
SCK	Serial Data Clock
SI	Serial Data Input
SO	Serial Data Output
GND	Ground
VCC	Power Supply
\overline{WP}	Write Protect
\overline{HOLD}	Suspends Serial Input

16-lead SOIC

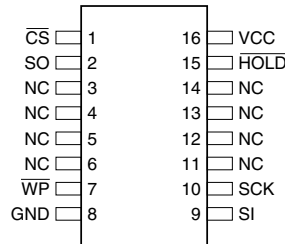

8-lead Leadless Array

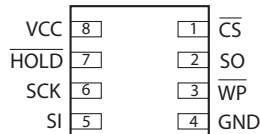

Bottom View

8-lead SOIC Array Package (SAP)

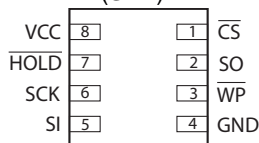

Bottom View

8-lead PDIP

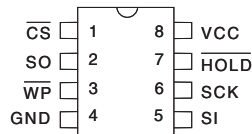

8-lead SOIC

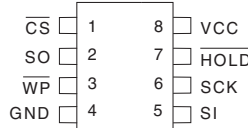

SPI Serial EEPROMs

256K (32,768 x 8)

512K (65,536 x 8)

AT25HP256⁽¹⁾ AT25HP512

Note: 1. Not recommended for new design; please refer to AT25256A datasheet.



The AT25HP256/512 is enabled through the Chip Select pin (\overline{CS}) and accessed via a 3-wire interface consisting of Serial Data Input (SI), Serial Data Output (SO), and Serial Clock (SCK). All programming cycles are completely self-timed, and no separate erase cycle is required before write.

Block Write protection is enabled by programming the status register with top $\frac{1}{4}$, top $\frac{1}{2}$ or entire array of write protection. Separate Program Enable and Program Disable instructions are provided for additional data protection. Hardware data protection is provided via the \overline{WP} pin to protect against inadvertent write attempts to the status register. The \overline{HOLD} pin may be used to suspend any serial communication without resetting the serial sequence.

Absolute Maximum Ratings*

Operating Temperature	-55°C to +125°C
Storage Temperature	-65°C to +150°C
Voltage on Any Pin with Respect to Ground	-1.0V to +7.0V
Maximum Operating Voltage	6.25V
DC Output Current.....	5.0 mA

*NOTICE: Stresses beyond those listed under “Absolute Maximum Ratings” may cause permanent damage to the device. This is a stress rating only and functional operation of the device at these or any other conditions beyond those indicated in the operational sections of this specification is not implied. Exposure to absolute maximum rating conditions for extended periods may affect device reliability.

Figure 1. Block Diagram

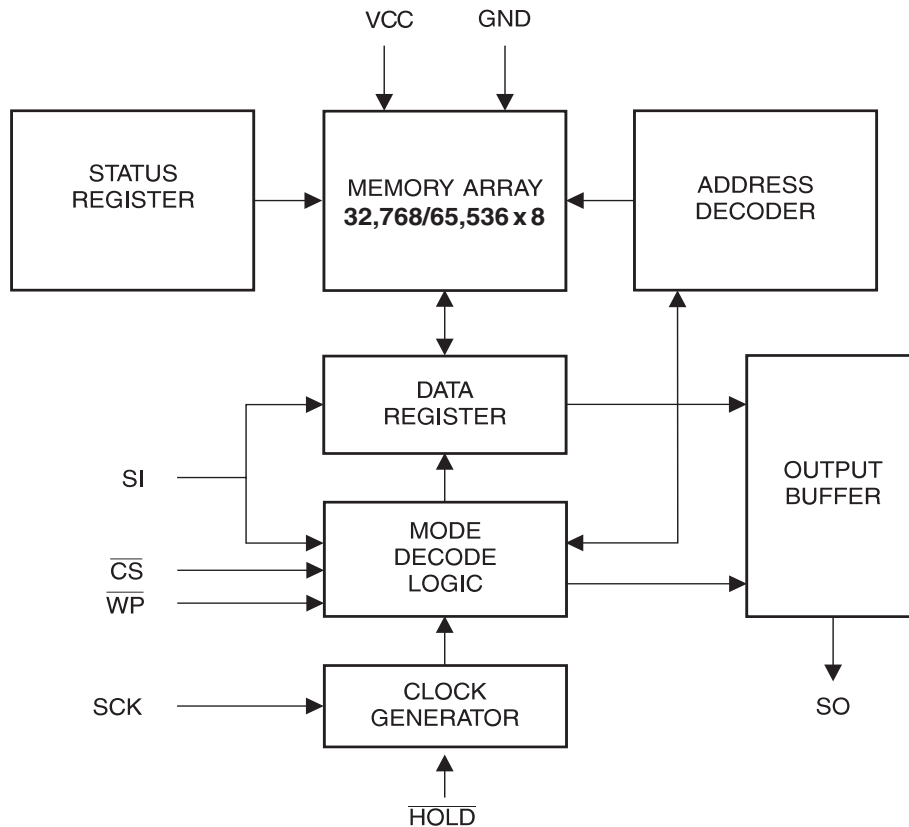

Table 2. Pin Capacitance⁽¹⁾

Applicable over recommended operating range from $T_A = 25^\circ\text{C}$, $f = 1.0\text{ MHz}$, $V_{CC} = +5.0\text{V}$ (unless otherwise noted)

Symbol	Test Conditions	Max	Units	Conditions
C_{OUT}	Output Capacitance (SO)	8	pF	$V_{OUT} = 0\text{V}$
C_{IN}	Input Capacitance (\overline{CS} , SCK, SI, \overline{WP} , \overline{HOLD})	6	pF	$V_{IN} = 0\text{V}$

Note: 1. This parameter is characterized and is not 100% tested.

Table 3. DC Characteristics

Applicable over recommended operating range from: $T_{AI} = -40^\circ\text{C}$ to $+85^\circ\text{C}$, $V_{CC} = +1.8\text{V}$ to $+5.5\text{V}$,
 $T_{AC} = 0^\circ\text{C}$ to $+70^\circ\text{C}$, $V_{CC} = +1.8\text{V}$ to $+5.5\text{V}$ (unless otherwise noted)

Symbol	Parameter	Test Condition	Min	Typ	Max	Units
V_{CC1}	Supply Voltage		1.8		3.6	V
V_{CC2}	Supply Voltage		2.7		5.5	V
V_{CC3}	Supply Voltage		4.5		5.5	V
I_{CC1}	Supply Current	$V_{CC} = 5.0\text{V}$ at 5 MHz, SO = Open Read		6.0	10.0	mA
I_{CC2}	Supply Current	$V_{CC} = 5.0\text{V}$ at 5 MHz, SO = Open Write		4.0	7.0	mA
I_{SB1}	Standby Current	$V_{CC} = 1.8\text{V}$, $\overline{CS} = V_{CC}$		0.1	2.0	μA
I_{SB2}	Standby Current	$V_{CC} = 2.7\text{V}$, $\overline{CS} = V_{CC}$		0.2	2.0	μA
I_{SB3}	Standby Current	$V_{CC} = 5.0\text{V}$, $\overline{CS} = V_{CC}$		2.0	5.0	μA
I_{IL}	Input Leakage	$V_{IN} = 0\text{V}$ to V_{CC}	-3.0		3.0	μA
I_{OL}	Output Leakage	$V_{IN} = 0\text{V}$ to V_{CC} , $T_{AC} = 0^\circ\text{C}$ to 70°C	-3.0		3.0	μA
$V_{IL}^{(1)}$	Input Low Voltage		-0.6		$V_{CC} \times 0.3$	V
$V_{IH}^{(1)}$	Input High Voltage		$V_{CC} \times 0.7$		$V_{CC} + 0.5$	V
V_{OL1}	Output Low Voltage	$4.5\text{V} \leq V_{CC} \leq 5.5\text{V}$			0.4	V
V_{OH1}	Output High Voltage			$I_{OL} = 3.0\text{ mA}$		V
V_{OL2}	Output Low Voltage	$1.8\text{V} \leq V_{CC} \leq 3.6\text{V}$			0.2	V
V_{OH2}	Output High Voltage			$I_{OH} = -1.6\text{ mA}$	$V_{CC} - 0.8$	V
						V
						V

Note: 1. V_{IL} and V_{IH} max are reference only and are not tested.

Table 4. AC Characteristics

Applicable over recommended operating range from $T_A = -40^{\circ}\text{C}$ to $+85^{\circ}\text{C}$, $V_{CC} = \text{As Specified}$, $C_L = 1$ TTL Gate and 30 pF (unless otherwise noted)

Symbol	Parameter	Voltage	Min	Max	Units
f_{SCK}	SCK Clock Frequency	4.5 – 5.5	0	10	MHz
		2.7 – 5.5	0	5	
		1.8 – 5.5	0	2	
t_{RI}	Input Rise Time	4.5 – 5.5		2	μs
		2.7 – 5.5		2	
		1.8 – 5.5		2	
t_{FI}	Input Fall Time	4.5 – 5.5		2	μs
		2.7 – 5.5		2	
		1.8 – 5.5		2	
t_{WH}	SCK High Time	4.5 – 5.5	40		ns
		2.7 – 5.5	80		
		1.8 – 5.5	200		
t_{WL}	SCK Low Time	4.5 – 5.5	40		ns
		2.7 – 5.5	80		
		1.8 – 5.5	200		
t_{CS}	$\overline{\text{CS}}$ High Time	4.5 – 5.5	50		ns
		2.7 – 5.5	100		
		1.8 – 5.5	250		
t_{CSS}	$\overline{\text{CS}}$ Setup Time	4.5 – 5.5	50		ns
		2.7 – 5.5	100		
		1.8 – 5.5	250		
t_{CSH}	$\overline{\text{CS}}$ Hold Time	4.5 – 5.5	50		ns
		2.7 – 5.5	100		
		1.8 – 5.5	250		
t_{SU}	Data In Setup Time	4.5 – 5.5	12		ns
		2.7 – 5.5	20		
		1.8 – 5.5	50		
t_{H}	Data In Hold Time	4.5 – 5.5	10		ns
		2.7 – 5.5	20		
		1.8 – 5.5	50		
t_{HD}	$\overline{\text{Hold}}$ Setup Time	4.5 – 5.5	25		ns
		2.7 – 5.5	50		
		1.8 – 5.5	100		
t_{CD}	$\overline{\text{Hold}}$ Hold Time	4.5 – 5.5	25		ns
		2.7 – 5.5	50		
		1.8 – 5.5	100		
t_{V}	Output Valid	4.5 – 5.5	0	40	ns
		2.7 – 5.5	0	80	
		1.8 – 5.5	0	200	
t_{HO}	Output Hold Time	4.5 – 5.5	0		ns
		2.7 – 5.5	0		
		1.8 – 5.5	0		
t_{LZ}	$\overline{\text{Hold}}$ to Output Low Z	4.5 – 5.5	0	100	ns
		2.7 – 5.5	0	200	
		1.8 – 5.5	0	300	

Table 4. AC Characteristics (Continued)

Applicable over recommended operating range from $T_A = -40^{\circ}\text{C}$ to $+85^{\circ}\text{C}$, $V_{CC} = \text{As Specified}$, $C_L = 1$ TTL Gate and 30 pF (unless otherwise noted)

Symbol	Parameter	Voltage	Min	Max	Units
t_{HZ}	$\overline{\text{Hold}}$ to Output High Z	4.5 – 5.5 2.7 – 5.5 1.8 – 5.5		100 200 300	ns
t_{DIS}	Output Disable Time	4.5 – 5.5 2.7 – 5.5 1.8 – 5.5		100 100 250	ns
t_{WC}	Write Cycle Time	4.5 – 5.5 2.7 – 5.5 1.8 – 5.5		10 10 10	ms
Endurance ⁽¹⁾	5.0V, 25°C, Page Mode	4.5 – 5.5 2.7 – 5.5 1.8 – 5.5	100K		Write Cycles

Note: 1. This parameter is characterized and is not 100% tested.



Serial Interface Description

MASTER: The device that generates the serial clock.

SLAVE: Because the serial clock pin (SCK) is always an input, the AT25HP256/512 always operates as a slave.

TRANSMITTER/RECEIVER: The AT25HP256/512 has separate pins designated for data transmission (SO) and reception (SI).

MSB: The Most Significant Bit (MSB) is the first bit transmitted and received.

SERIAL OP-CODE: After the device is selected with \overline{CS} going low, the first byte will be received. This byte contains the op-code that defines the operations to be performed.

INVALID OP-CODE: If an invalid op-code is received, no data will be shifted into the AT25HP256/512, and the serial output pin (SO) will remain in a high impedance state until the falling edge of \overline{CS} is detected again. This will reinitialize the serial communication.

CHIP SELECT: The AT25HP256/512 is selected when the \overline{CS} pin is low. When the device is not selected, data will not be accepted via the SI pin, and the SO will remain in a high impedance state.

HOLD: The \overline{HOLD} pin is used in conjunction with the \overline{CS} pin to select the AT25HP256/512. When the device is selected and a serial sequence is underway, \overline{HOLD} can be used to pause the serial communication with the master device without resetting the serial sequence. To pause, the \overline{HOLD} pin must be brought low while the SCK pin is low. To resume serial communication, the \overline{HOLD} pin is brought high while the SCK pin is low (SCK may still toggle during \overline{HOLD}). Inputs to the SI pin will be ignored while the SO pin is in the high impedance state.

WRITE PROTECT: The write protect pin (\overline{WP}) will allow normal read/write operations when held high. When the \overline{WP} pin is brought low and WPEN bit is "1", all write operations to the status register are inhibited. \overline{WP} going low while \overline{CS} is still low will interrupt a write to the status register. If the internal write cycle has already been initiated, \overline{WP} going low will have no effect on any write operation to the status register. The \overline{WP} pin function is blocked when the WPEN bit in the status register is "0". This will allow the user to install the AT25HP256/512 in a system with the \overline{WP} pin tied to ground and still be able to write to the status register. All \overline{WP} pin functions are enabled when the WPEN bit is set to "1".

SPI Serial Interface

Figure 2. Functional Description

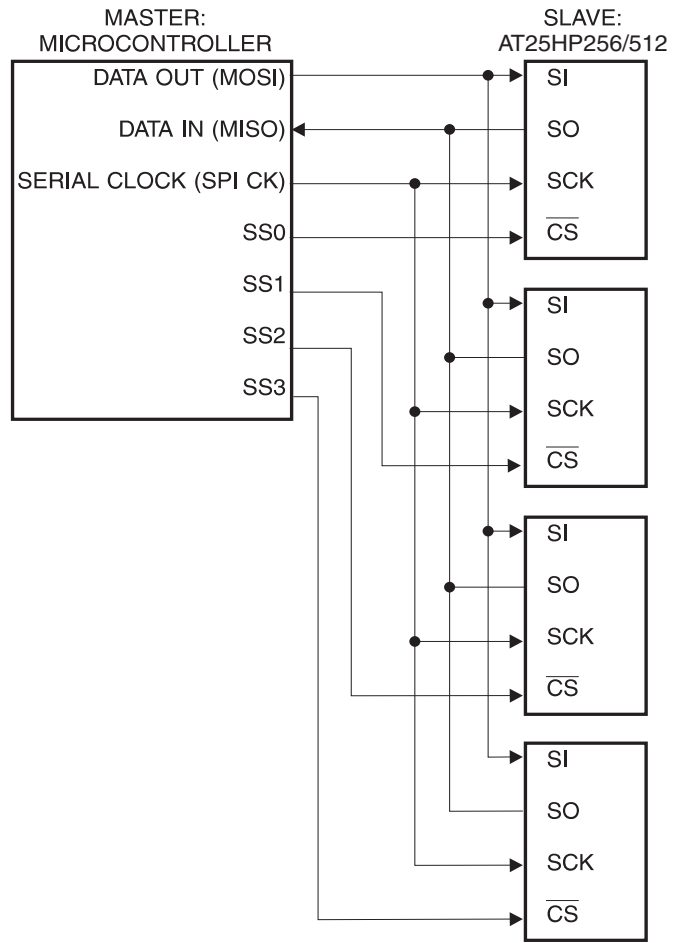



The AT25HP256/512 is designed to interface directly with the synchronous serial peripheral interface (SPI) of the 6800 type series of microcontrollers.

The AT25HP256/512 utilizes an 8-bit instruction register. The list of instructions and their operation codes are contained in Table 5. All instructions, addresses, and data are transferred with the MSB first and start with a high-to-low \overline{CS} transition.

Table 5. Instruction Set for the AT25HP256/512

Instruction Name	Instruction Format	Operation
WREN	0000 X110	Set Write Enable Latch
WRDI	0000 X100	Reset Write Enable Latch
RDSR	0000 X101	Read Status Register
WRSR	0000 X001	Write Status Register
READ	0000 X011	Read Data from Memory Array
WRITE	0000 X010	Write Data to Memory Array

WRITE ENABLE (WREN): The device will power up in the write disable state when V_{CC} is applied. All programming instructions must therefore be preceded by a Write Enable instruction.

WRITE DISABLE (WRDI): To protect the device against inadvertent writes, the Write Disable instruction disables all programming modes. The WRDI instruction is independent of the status of the \overline{WP} pin.

READ STATUS REGISTER (RDSR): The Read Status Register instruction provides access to the status register. The Ready/Busy and Write Enable status of the device can be determined by the RDSR instruction. Similarly, the block write protection bits indicate the extent of protection employed. These bits are set by using the WRSR instruction.

Table 6. Status Register Format

Bit 7	Bit 6	Bit 5	Bit 4	Bit 3	Bit 2	Bit 1	Bit 0
WPEN	X	X	X	BP1	BP0	WEN	\overline{RDY}

Table 7. Read Status Register Bit Definition

Bit	Definition
Bit 0 ($\overline{\text{RDY}}$)	Bit 0 = "0" ($\overline{\text{RDY}}$) indicates the device is ready. Bit 0 = "1" indicates the write cycle is in progress.
Bit 1 (WEN)	Bit 1 = "0" indicates the device <i>is not</i> write-enabled. Bit 1 = "1" indicates the device is write-enabled.
Bit 2 (BP0)	See Table 8.
Bit 3 (BP1)	See Table 8.
Bits 4-6 are "0"s when device is not in an internal write cycle.	
Bit 7 (WPEN)	See Table 9.
Bits 0-7 are "1"s during an internal write cycle.	

WRITE STATUS REGISTER (WRSR): The WRSR instruction allows the user to select one of four levels of protection. The AT25HP256/512 is divided into four array segments. Top quarter (1/4), top half (1/2), or all of the memory segments can be protected. Any of the data within any selected segment will therefore be READ only. The block write protection levels and corresponding status register control bits are shown in Table 8.

The three bits, BP0, BP1, and WPEN are nonvolatile cells that have the same properties and functions as the regular memory cells (e.g., WREN, t_{WC} , RDSR).

Table 8. Block Write Protect Bits

Level	Status Register Bits		Array Addresses Protected
	BP1	BP0	AT25HP256/512
0	0	0	None
1(1/4)	0	1	6000 - 7FFF/C000 - FFFF
2(1/2)	1	0	4000 - 7FFF/8000 - FFFF
3(All)	1	1	0000 - 7FFF/0000 - FFFF

The WRSR instruction also allows the user to enable or disable the write protect ($\overline{\text{WP}}$) pin through the use of the write protect enable (WPEN) bit. Hardware write protection is enabled when the $\overline{\text{WP}}$ pin is low and the WPEN bit is "1". Hardware write protection is disabled when *either* the $\overline{\text{WP}}$ pin is high or the WPEN bit is "0." When the device is hardware write protected, writes to the status register, including the block protect bits and the WPEN bit, and the block-protected sections in the memory array are disabled. Writes are only allowed to sections of the memory which are not block-protected.

NOTE: When the WPEN bit is hardware write protected, it cannot be changed back to "0" as long as the $\overline{\text{WP}}$ pin is held low.

Table 9. WPEN Operation

WPEN	WP	WEN	ProtectedBlocks	UnprotectedBlocks	Status Register
0	X	0	Protected	Protected	Protected
0	X	1	Protected	Writable	Writable
1	Low	0	Protected	Protected	Protected

Table 9. WPEN Operation (Continued)

WPEN	WP	WEN	ProtectedBlocks	UnprotectedBlocks	Status Register
1	Low	1	Protected	Writable	Protected
X	High	0	Protected	Protected	Protected
X	High	1	Protected	Writable	Writable

READ SEQUENCE (READ): Reading the AT25HP256/512 via the SO pin requires the following sequence. After the \overline{CS} line is pulled low to select a device, the read op-code is transmitted via the SI line followed by the byte address to be read (see Table 10). Upon completion, any data on the SI line will be ignored. The data (D7–D0) at the specified address is then shifted out onto the SO line. If only one byte is to be read, the \overline{CS} line should be driven high after the data comes out. The read sequence can be continued since the byte address is automatically incremented and data will continue to be shifted out. When the highest address is reached, the address counter will roll over to the lowest address allowing the entire memory to be read in one continuous read cycle.

WRITE SEQUENCE (WRITE): In order to program the AT25HP256/512, two separate instructions must be executed. First, the device *must be write enabled* via the WREN instruction. Then a Write instruction may be executed. Also, the address of the memory location(s) to be programmed must be outside the protected address field location selected by the block write protection level. During an internal write cycle, all commands will be ignored except the RDSR instruction.

A Write instruction requires the following sequence. After the \overline{CS} line is pulled low to select the device, the Write op-code is transmitted via the SI line followed by the byte address and the data (D7–D0) to be programmed (see Table 10). Programming will start after the \overline{CS} pin is brought high. The Low-to-High transition of the \overline{CS} pin must occur during the SCK low time immediately after clocking in the D0 (LSB) data bit.

The Ready/Busy status of the device can be determined by initiating a Read Status Register (RDSR) instruction. If Bit 0 = “1”, the write cycle is still in progress. If Bit 0 = “0”, the write cycle has ended. Only the RDSR instruction is enabled during the write programming cycle.

The AT25HP256/512 is capable of a 128-byte page write operation. After each byte of data is received, the seven low-order address bits are internally incremented by one; the high-order bits of the address will remain constant. If more than 128 bytes of data are transmitted, the address counter will roll over and the previously written data will be overwritten. The AT25HP256/512 is automatically returned to the write disable state at the completion of a write cycle.

NOTE: If the device is not write enabled (WREN), the device will ignore the Write instruction and will return to the standby state, when \overline{CS} is brought high. A new \overline{CS} falling edge is required to reinitiate the serial communication.

Table 10. Address Key

Address	AT25HP256/512
A_N	$A_{14} - A_0 / A_{15} - A_0$
Don't Care Bits	A_{15} / none

NOTE: 128-byte Page Write operation only. Content of the page in the array will not be guaranteed if less than 128 bytes of data is received (byte write is not supported).

Timing Diagrams (for SPI Mode 0 (0,0))

Figure 3. Synchronous Data Timing

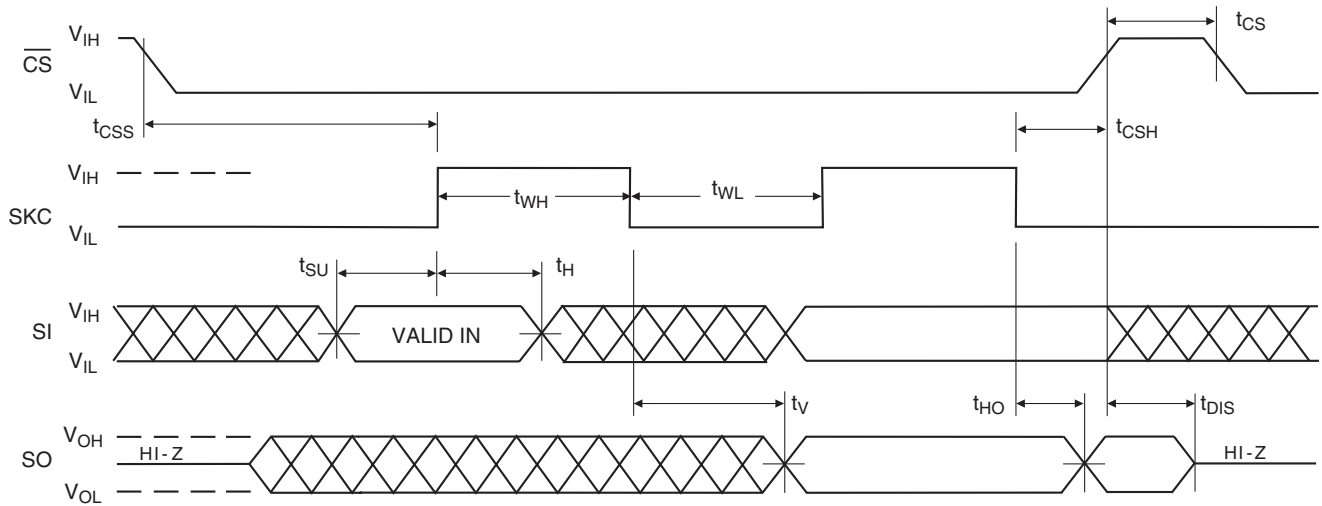

Figure 4. WREN Timing

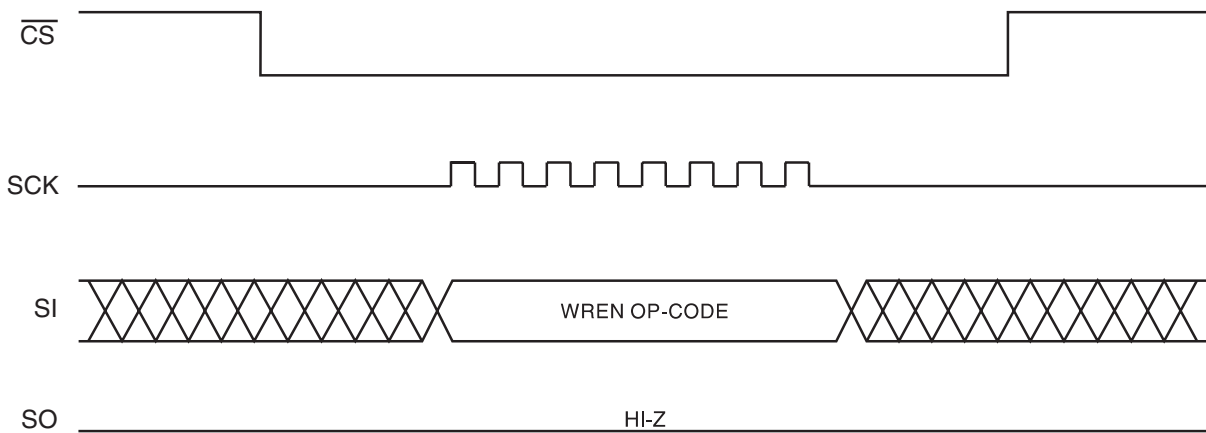

Figure 5. WRDI Timing

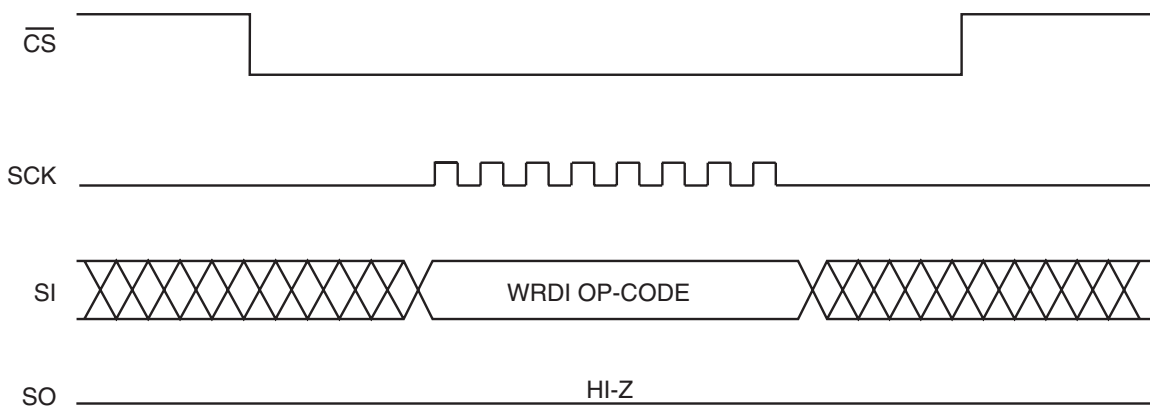

Figure 6. RDSR Timing

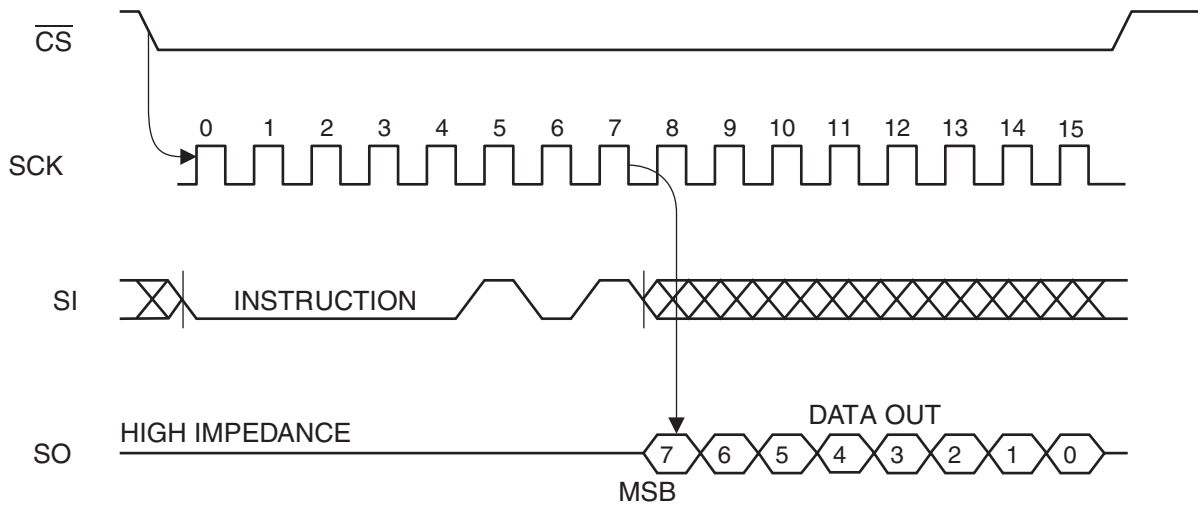

Figure 7. WRSR Timing

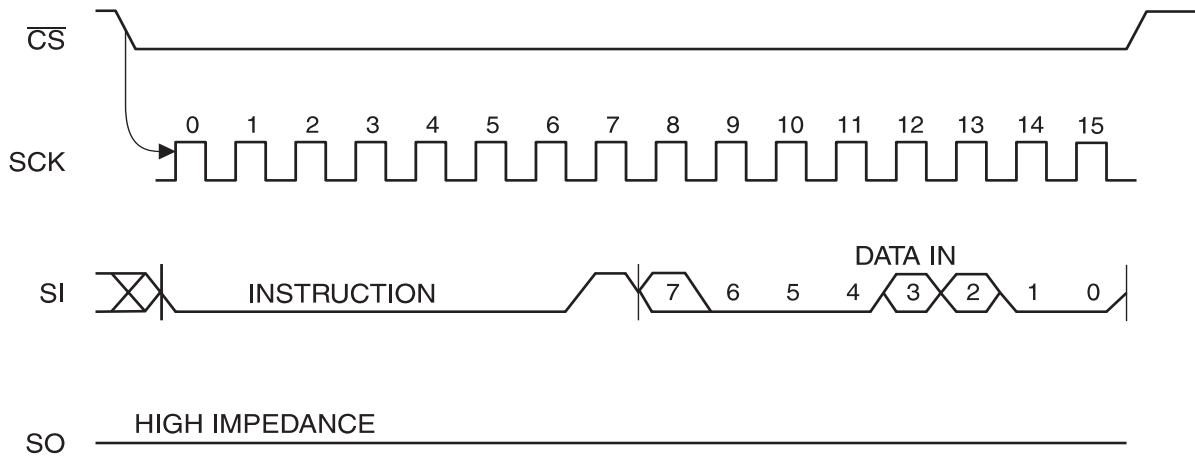

Figure 8. READ Timing

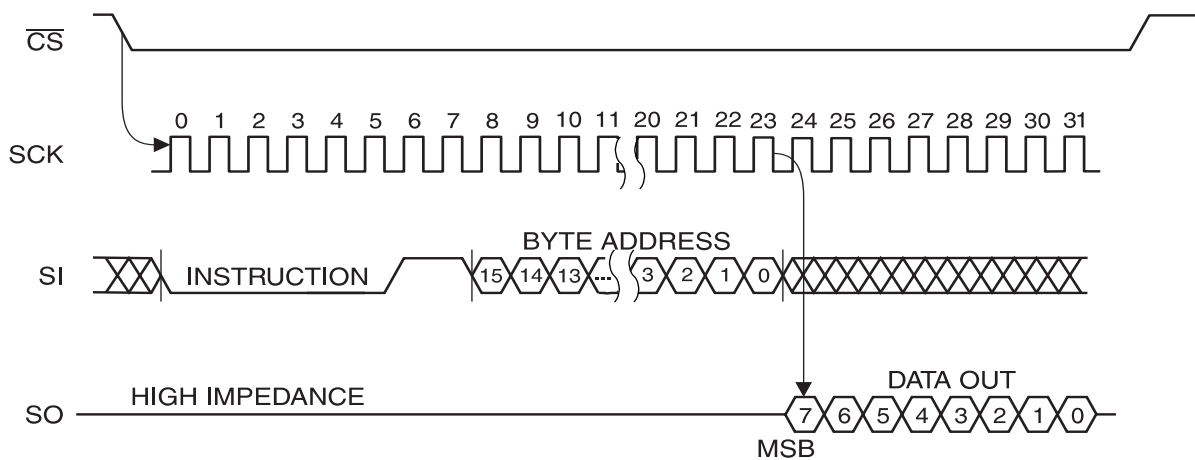

Figure 9. WRITE Timing (AT25HP256)

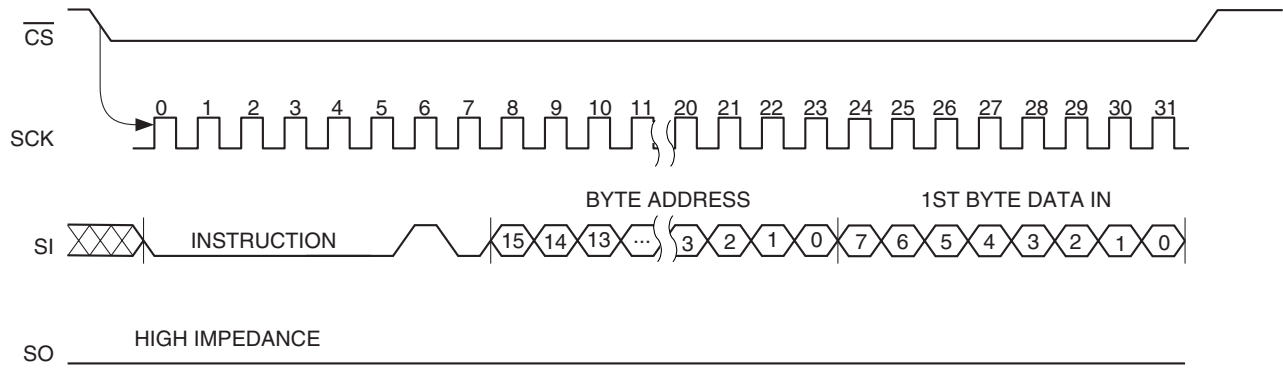

Figure 10. PAGE WRITE Timing (AT25HP512)

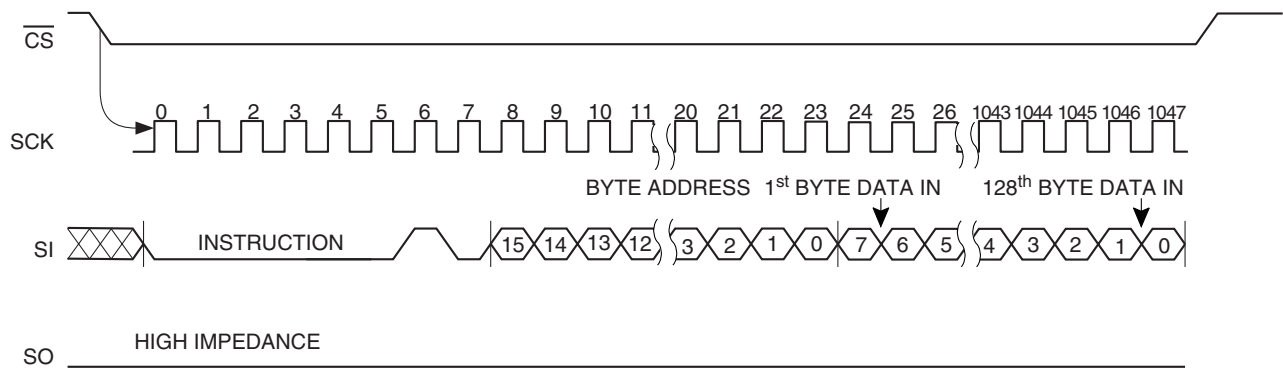
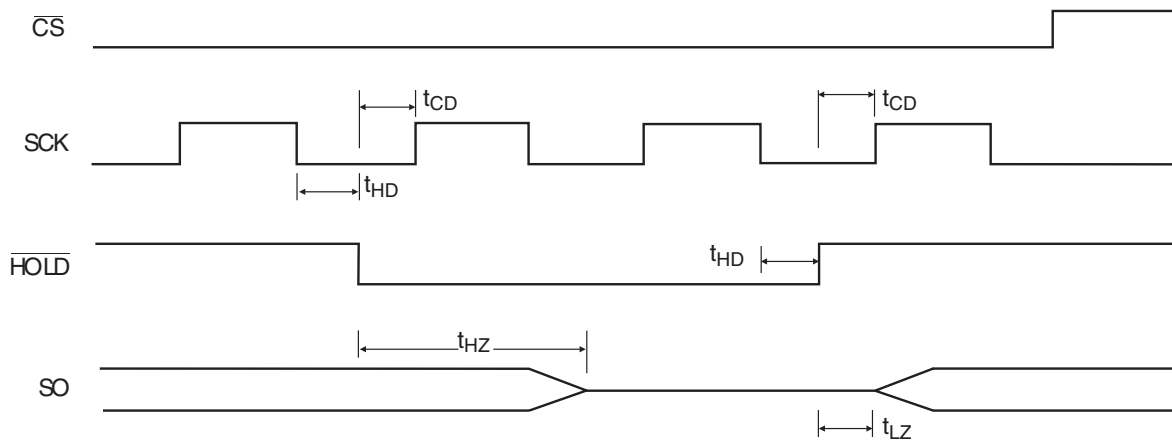

Figure 11. HOLD Timing





AT25HP256 Ordering Information⁽¹⁾

Ordering Code	Package	Operation Range
AT25HP256-10PU-2.7 ⁽²⁾	8P3	Lead-free/Halogen-free/ Industrial Temperature (-40°C to 85°C)
AT25HP256-10PU-1.8 ⁽²⁾	8P3	
AT25HP256W-10SU-2.7 ⁽²⁾	8S2	
AT25HP256W-10SU-1.8 ⁽²⁾	8S2	
AT25HP256C1-10CU-2.7 ⁽²⁾	8CN1	
AT25HP256C1-10CU-1.8 ⁽²⁾	8CN1	
AT25HP256Y4-10YU-1.8 ⁽²⁾	8Y4	
AT25HP256-W2.7-11 ⁽³⁾	Die Sale	Industrial Temperature (-40°C to 85°C)
AT25HP256-W1.8-11 ⁽³⁾	Die Sale	

- Notes:
1. This device is not recommended for new design. Please refer to AT25256A datasheet. For 2.7 devices used in 4.5V to 5.5V range, please refer to performance values in the AC and DC characteristics table.
 2. "U" designates Green Package & RoHS compliant.
 3. Available in wafer pack and wafer form; order as SL719 for wafer form. Bumped die available upon request. Please contact Serial EEPROM marketing.

Package Type	
8CN1	8-lead, 0.300" Wide, Leadless Array Package (LAP)
8P3	8-lead, 0.300" Wide, Plastic Dual In-line Package (PDIP)
8S2	8-lead, 0.200" Wide, Plastic Small Outline Package (EIAJ)
8Y4	8-lead, 6.00 mm x 4.90 mm Body, Dual Footprint, Non-leaded, Small Array Package (SAP)
Options	
-2.7	Low Voltage (2.7V to 5.5V)
-1.8	Low Voltage (1.8V to 5.5V)

AT25HP512 Ordering Information⁽¹⁾

Ordering Code	Package	Operation Range
AT25HP512C1-10CI-2.7 AT25HP512-10PI-2.7 AT25HP512W2-10SI-2.7	8CN1 8P3 16S2	Industrial Temperature (-40°C to 85°C)
AT25HP512C1-10CI-1.8 AT25HP512-10PI-1.8 AT25HP512W2-10SI-1.8	8CN1 8P3 16S2	Industrial Temperature (-40°C to 85°C)
AT25HP512C1-10CU-2.7 ⁽²⁾ AT25HP512C1-10CU-1.8 ⁽²⁾ AT25HP512-10PU-2.7 ⁽²⁾ AT25HP512-10PU-1.8 ⁽²⁾ AT25HP512W2-10SU-2.7 ⁽²⁾ AT25HP512W2-10SU-1.8 ⁽²⁾	8CN1 8CN1 8P3 8P3 16S2 16S2	Lead-free/ Halogen-free Industrial Temperature (-40°C to 85°C)
AT25HP512-W2.7-11 ⁽³⁾ AT25HP512-W1.8-11 ⁽³⁾	Die Sale Die Sale	Industrial Temperature (-40°C to 85°C)

- Notes:
1. For 2.7V devices used in the 4.5V to 5.5V range, please refer to performance values in the AC and DC characteristics tables.
 2. "U" designates Green Package & RoHS compliant.
 3. Available in waffle pack and wafer form; order as SL719 for wafer form. Bumped die available upon request. Contact Serial EEPROM marketing.

Package Type	
8CN1	8-lead, 0.300" Wide, Leadless Array Package (LAP)
8P3	8-lead, 0.300" Wide, Plastic Dual In-line Package (PDIP)
16S2	16-lead, 0.300" Wide, Plastic Gull Wing Small Outline Package (JEDEC SOIC)
Options	
-2.7	Low Voltage (2.7V to 5.5V)
-1.8	Low Voltage (1.8V to 5.5V)



Packaging Information

8CN1 – LAP

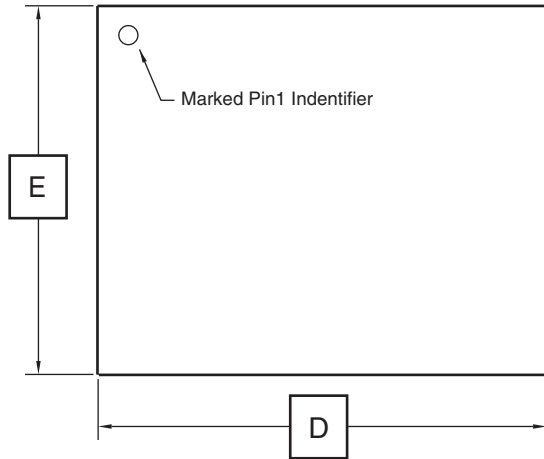

Top View

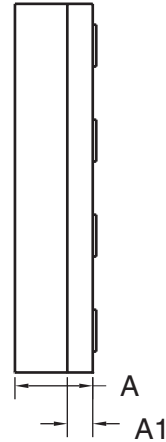

Side View

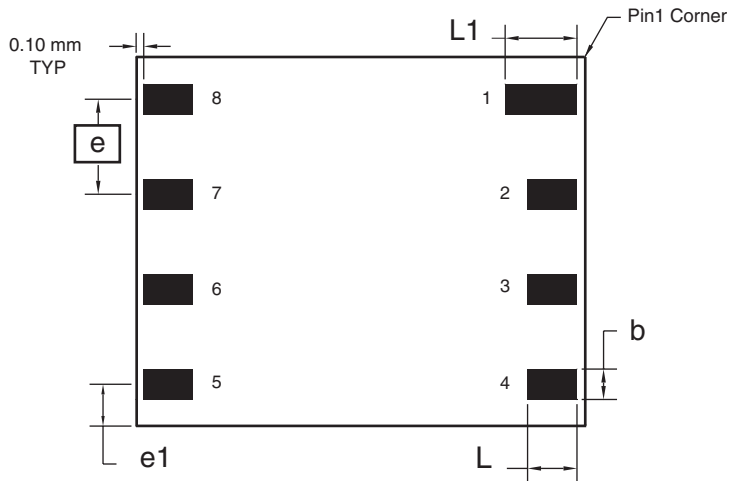

Bottom View

COMMON DIMENSIONS
(Unit of Measure = mm)

SYMBOL	MIN	NOM	MAX	NOTE
A	0.94	1.04	1.14	
A1	0.30	0.34	0.38	
b	0.36	0.41	0.46	1
D	7.90	8.00	8.10	
E	4.90	5.00	5.10	
e	1.27 BSC			
e1	0.60 REF			
L	0.62	.0.67	0.72	1
L1	0.92	0.97	1.02	1

Note: 1. Metal Pad Dimensions.

11/13/01

8P3 – PDIP

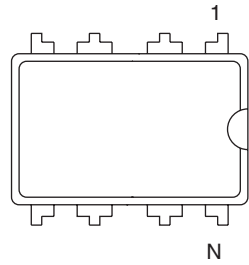

Top View

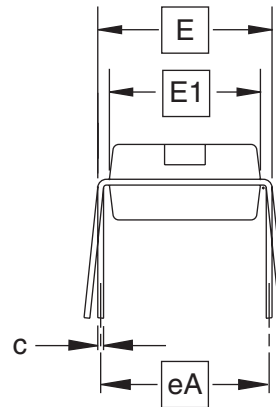

End View

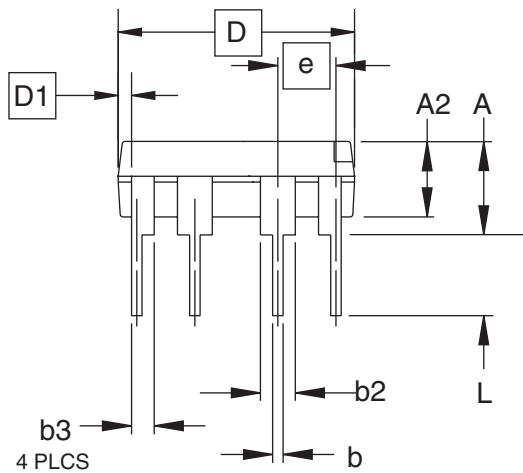

Side View

COMMON DIMENSIONS
(Unit of Measure = inches)

SYMBOL	MIN	NOM	MAX	NOTE
A	–	–	0.210	2
A2	0.115	0.130	0.195	
b	0.014	0.018	0.022	5
b2	0.045	0.060	0.070	6
b3	0.030	0.039	0.045	6
c	0.008	0.010	0.014	
D	0.355	0.365	0.400	3
D1	0.005	–	–	3
E	0.300	0.310	0.325	4
E1	0.240	0.250	0.280	3
e	0.100 BSC			
eA	0.300 BSC			4
L	0.115	0.130	0.150	2

- Notes:
1. This drawing is for general information only; refer to JEDEC Drawing MS-001, Variation BA, for additional information.
 2. Dimensions A and L are measured with the package seated in JEDEC seating plane Gauge GS-3.
 3. D, D1 and E1 dimensions do not include mold Flash or protrusions. Mold Flash or protrusions shall not exceed 0.010 inch.
 4. E and eA measured with the leads constrained to be perpendicular to datum.
 5. Pointed or rounded lead tips are preferred to ease insertion.
 6. b2 and b3 maximum dimensions do not include Dambar protrusions. Dambar protrusions shall not exceed 0.010 (0.25 mm).

01/09/02



2325 Orchard Parkway
San Jose, CA 95131

TITLE

8P3, 8-lead, 0.300" Wide Body, Plastic Dual
In-line Package (PDIP)

DRAWING NO.

8P3

REV.

B



16S2 – JEDEC SOIC

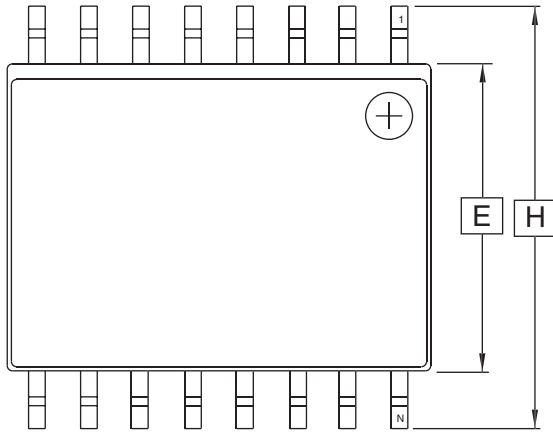

Top View

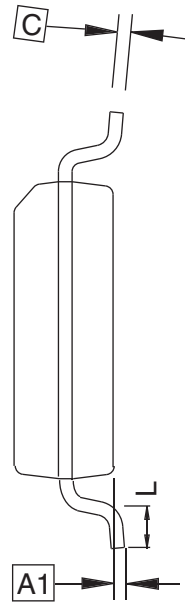

End View

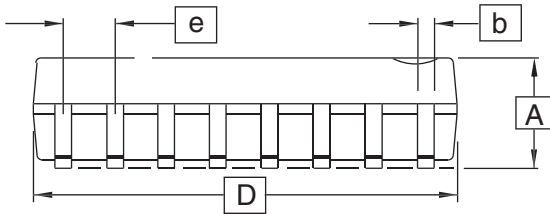

Side View

COMMON DIMENSIONS
(Unit of Measure = inches)

SYMBOL	MIN	NOM	MAX	NOTE
A	0.0926	–	0.1043	
A1	0.0040	–	0.0118	
b	0.0130	–	0.0200	5
C	0.0091	–	0.0125	
D	0.3977	–	0.4133	2
E	0.2914	–	0.2992	3
H	0.3940	–	0.4190	
L	0.0160	–	0.050	4
e	0.050 BSC			

- Notes: 1. This drawing is for general information only; refer to JEDEC drawing MS-013, Variation AA, for additional information.
 2. Dimension D does not include mold Flash, protrusions or gate burrs. Mold Flash, protrusions and gate burrs shall not exceed 0.15 mm (0.006") per side.
 3. Dimension E does not include inter-lead Flash or protrusion. Inter-lead Flash and protrusions shall not exceed 0.25 mm (0.010") per side.
 4. L is the length of the terminal for soldering to a substrate.
 5. The lead width B, as measured 0.36 mm (0.014") or greater above the seating plane, shall not exceed a maximum value of 0.61 mm (0.024") per side.

1/9/02



2325 Orchard Parkway
San Jose, CA 95131

TITLE

16S2, 16-lead, 0.300" Wide Body, Plastic Gull Wing Small Outline Package (SOIC)

DRAWING NO.

16S2

REV.

A

8S2 – EIAJ SOIC

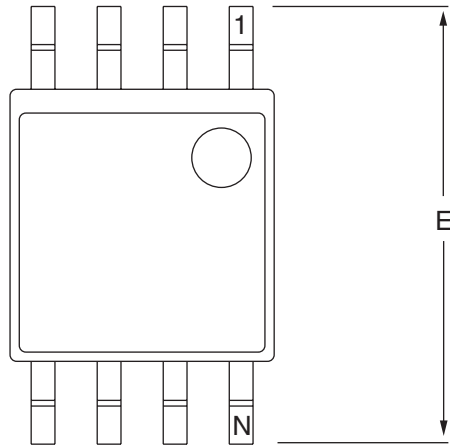

Top View

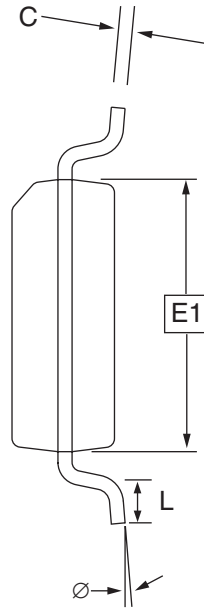

End View

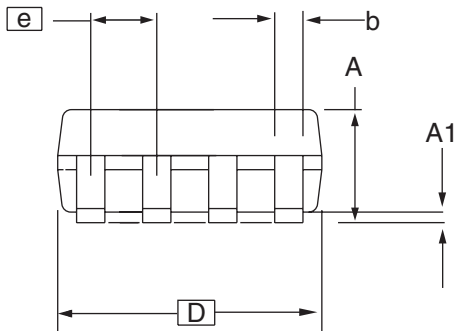

Side View

COMMON DIMENSIONS

(Unit of Measure = mm)

SYMBOL	MIN	NOM	MAX	NOTE
A	1.70		2.16	
A1	0.05		0.25	
b	0.35		0.48	5
C	0.15		0.35	5
D	5.13		5.35	
E1	5.18		5.40	2, 3
E	7.70		8.26	
L	0.51		0.85	
Ø	0°		8°	
e	1.27 BSC			4

- Notes: 1. This drawing is for general information only; refer to EIAJ Drawing EDR-7320 for additional information.
 2. Mismatch of the upper and lower dies and resin burrs are not included.
 3. It is recommended that upper and lower cavities be equal. If they are different, the larger dimension shall be regarded.
 4. Determines the true geometric position.
 5. Values b and C apply to pb/Sn solder plated terminal. The standard thickness of the solder layer shall be 0.010 +0.010/-0.005 mm.

10/7/03



2325 Orchard Parkway
San Jose, CA 95131

TITLE
8S2, 8-lead, 0.209" Body, Plastic Small
Outline Package (EIAJ)

DRAWING NO.
8S2

REV.
C



8Y4 – SAP

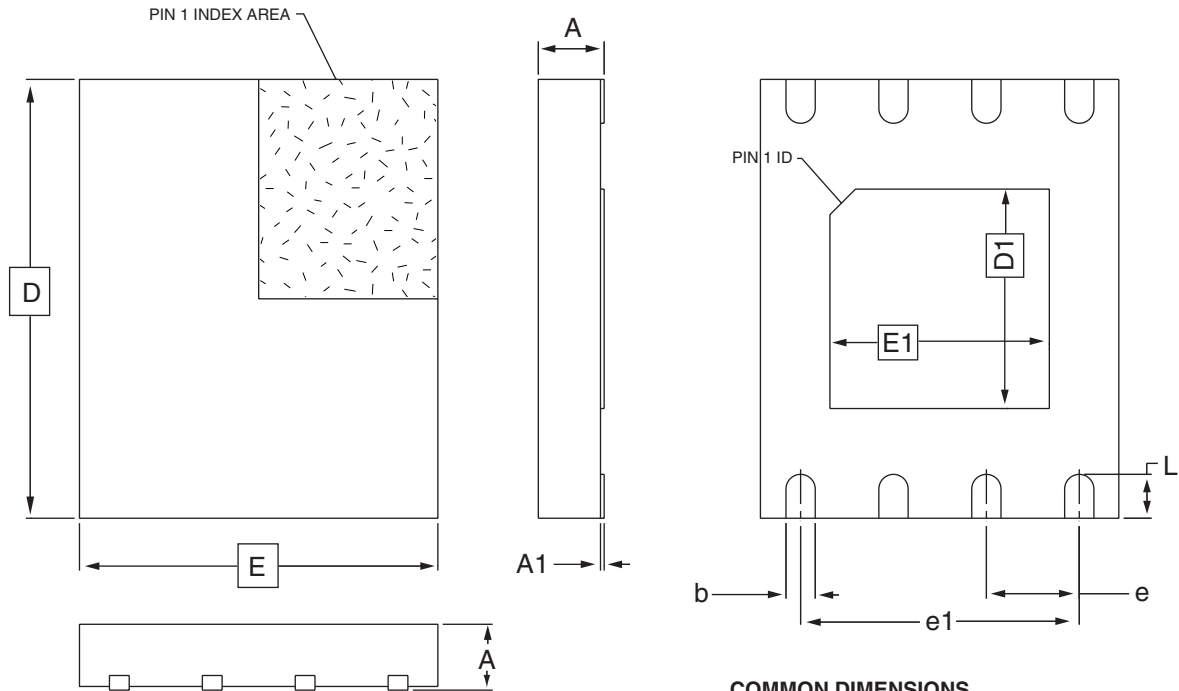

COMMON DIMENSIONS
(Unit of Measure = mm)

SYMBOL	MIN	NOM	MAX	NOTE
A	–	–	0.90	
A1	0.00	–	0.05	
D	5.80	6.00	6.20	
E	4.70	4.90	5.10	
D1	2.85	3.00	3.15	
E1	2.85	3.00	3.15	
b	0.35	0.40	0.45	
e	1.27 TYP			
e1	3.81 REF			
L	0.50	0.60	0.70	

5/24/04



1150 E. Cheyenne Mtn. Blvd.
Colorado Springs, CO 80906

TITLE

8Y4, 8-lead (6.00 x 4.90 mm Body) SOIC Array Package
(SAP) Y4

DRAWING NO.

8Y4

REV.

A



Atmel Corporation

2325 Orchard Parkway
San Jose, CA 95131, USA
Tel: 1(408) 441-0311
Fax: 1(408) 487-2600

Regional Headquarters

Europe

Atmel Sarl
Route des Arsenalux 41
Case Postale 80
CH-1705 Fribourg
Switzerland
Tel: (41) 26-426-5555
Fax: (41) 26-426-5500

Asia

Room 1219
Chinachem Golden Plaza
77 Mody Road Tsimshatsui
East Kowloon
Hong Kong
Tel: (852) 2721-9778
Fax: (852) 2722-1369

Japan

9F, Tonetsu Shinkawa Bldg.
1-24-8 Shinkawa
Chuo-ku, Tokyo 104-0033
Japan
Tel: (81) 3-3523-3551
Fax: (81) 3-3523-7581

Atmel Operations

Memory

2325 Orchard Parkway
San Jose, CA 95131, USA
Tel: 1(408) 441-0311
Fax: 1(408) 436-4314

Microcontrollers

2325 Orchard Parkway
San Jose, CA 95131, USA
Tel: 1(408) 441-0311
Fax: 1(408) 436-4314

La Chantrerie
BP 70602
44306 Nantes Cedex 3, France
Tel: (33) 2-40-18-18-18
Fax: (33) 2-40-18-19-60

ASIC/ASSP/Smart Cards

Zone Industrielle
13106 Rousset Cedex, France
Tel: (33) 4-42-53-60-00
Fax: (33) 4-42-53-60-01

1150 East Cheyenne Mtn. Blvd.
Colorado Springs, CO 80906, USA
Tel: 1(719) 576-3300
Fax: 1(719) 540-1759

Scottish Enterprise Technology Park
Maxwell Building
East Kilbride G75 0QR, Scotland
Tel: (44) 1355-803-000
Fax: (44) 1355-242-743

RF/Automotive

Theresienstrasse 2
Postfach 3535
74025 Heilbronn, Germany
Tel: (49) 71-31-67-0
Fax: (49) 71-31-67-2340

1150 East Cheyenne Mtn. Blvd.
Colorado Springs, CO 80906, USA
Tel: 1(719) 576-3300
Fax: 1(719) 540-1759

Biometrics/Imaging/Hi-Rel MPU/ High Speed Converters/RF Datacom

Avenue de Rochepleine
BP 123
38521 Saint-Egreve Cedex, France
Tel: (33) 4-76-58-30-00
Fax: (33) 4-76-58-34-80

Literature Requests

www.atmel.com/literature

Disclaimer: The information in this document is provided in connection with Atmel products. No license, express or implied, by estoppel or otherwise, to any intellectual property right is granted by this document or in connection with the sale of Atmel products. **EXCEPT AS SET FORTH IN ATMEL'S TERMS AND CONDITIONS OF SALE LOCATED ON ATMEL'S WEB SITE, ATMEL ASSUMES NO LIABILITY WHATSOEVER AND DISCLAIMS ANY EXPRESS, IMPLIED OR STATUTORY WARRANTY RELATING TO ITS PRODUCTS INCLUDING, BUT NOT LIMITED TO, THE IMPLIED WARRANTY OF MERCHANTABILITY, FITNESS FOR A PARTICULAR PURPOSE, OR NON-INFRINGEMENT. IN NO EVENT SHALL ATMEL BE LIABLE FOR ANY DIRECT, INDIRECT, CONSEQUENTIAL, PUNITIVE, SPECIAL OR INCIDENTAL DAMAGES (INCLUDING, WITHOUT LIMITATION, DAMAGES FOR LOSS OF PROFITS, BUSINESS INTERRUPTION, OR LOSS OF INFORMATION) ARISING OUT OF THE USE OR INABILITY TO USE THIS DOCUMENT, EVEN IF ATMEL HAS BEEN ADVISED OF THE POSSIBILITY OF SUCH DAMAGES.** Atmel makes no representations or warranties with respect to the accuracy or completeness of the contents of this document and reserves the right to make changes to specifications and product descriptions at any time without notice. Atmel does not make any commitment to update the information contained herein. Unless specifically provided otherwise, Atmel products are not suitable for, and shall not be used in, automotive applications. Atmel's products are not intended, authorized, or warranted for use as components in applications intended to support or sustain life.

© Atmel Corporation 2006. **All rights reserved.** Atmel®, logo and combinations thereof, Everywhere You Are® and others, are registered trademarks or trademarks of Atmel Corporation or its subsidiaries. Other terms and product names may be trademarks of others.



Printed on recycled paper.

1113L-SEEPR-3/06

Looking for pricing, stock, or lifecycle information?

Click below to explore more details on WIN SOURCE:

- ⊖ [View AT25HP512-10PI-2.7 on WIN SOURCE](#)
- ⊖ [Microchip Technology](#) Information

Optimize Your Supply Chain with WIN SOURCE Solutions

- ✓ Global Sourcing Solution
- ✓ Obsolete Management
- ✓ Cost Control Management
- ✓ Shortage Management
- ✓ Alternative Solution
- ✓ Excess Inventory Management