



**THE DATASHEET OF  
LM5067MW-1/NOPB**



## Negative Hot Swap / Inrush Current Controller with Power Limiting

Check for Samples: [LM5067](#)

### FEATURES

- **Wide operating range: -9V to -80V**
- **In-rush current limit for safe board insertion into live power sources**
- **Programmable maximum power dissipation in the external pass device**
- **Adjustable current limit**
- **Circuit breaker function for severe over-current events**
- **Adjustable under-voltage lockout (UVLO) and hysteresis**
- **Adjustable over-voltage lockout (OVLO) and hysteresis**
- **Initial insertion timer allows ringing and transients to subside after system connection**
- **Programmable fault timer avoids nuisance trips**
- **Active high open drain POWER GOOD output**
- **Available in latched fault and automatic restart versions**

### PACKAGES

- VSSOP-10
- SOIC-14 (Latched Fault Version)

### DESCRIPTION

The LM5067 negative hot swap controller provides intelligent control of the power supply connections during insertion and removal of circuit cards from a live system backplane or other “hot” power sources. The LM5067 provides in-rush current control to limit system voltage droop and transients. The current limit and power dissipation in the external series pass N-Channel MOSFET are programmable, ensuring operation within the Safe Operating Area (SOA). In addition, the LM5067 provides circuit protection by monitoring for over-current and over-voltage conditions. The POWER GOOD output indicates when the output voltage is close to the input voltage. The input under-voltage and over-voltage lockout levels and hysteresis are programmable, as well as the fault detection time. The LM5067-1 latches off after a fault detection, while the LM5067-2 automatically attempts restarts at a fixed duty cycle. The LM5067 is available in a 10-pin VSSOP package and a 14-pin SOIC package.

### APPLICATIONS

- **Server Backplane Systems**
- **In-Rush Current Limiting**
- **Solid State Circuit Breaker**
- **Transient Voltage Protector**
- **Solid State Relay**
- **Under-voltage Lock-out**
- **Power Good Detector/Indicator**

### Typical Application

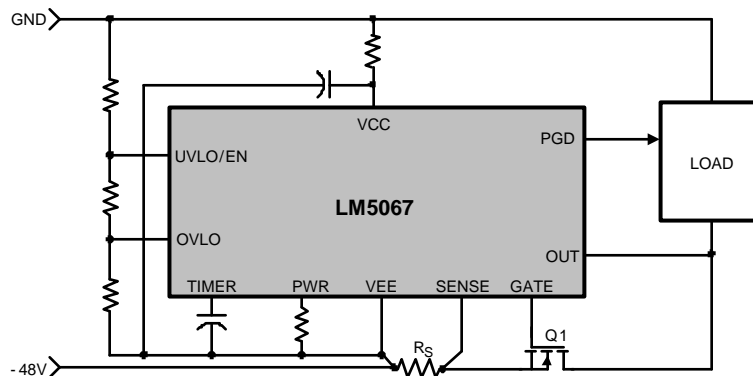

**Figure 1. Negative Power Bus In-Rush and Fault Protection**



Please be aware that an important notice concerning availability, standard warranty, and use in critical applications of Texas Instruments semiconductor products and disclaimers thereto appears at the end of this data sheet.

All trademarks are the property of their respective owners.

## Connection Diagram

NOTE: N/C Pins are internally not connected to anything.

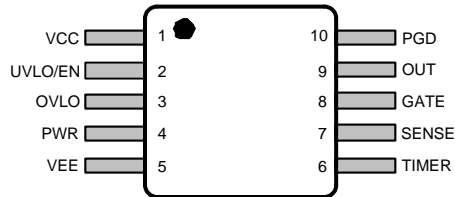

**Figure 2. Top View  
10-Lead VSSOP**

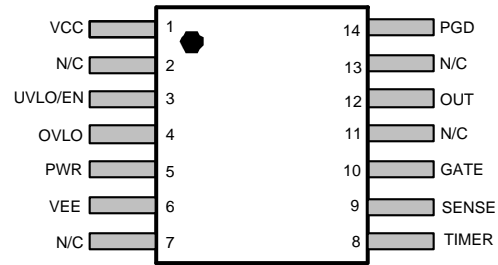

**Figure 3. Top View  
14-Lead SOIC**

### PIN DESCRIPTIONS

Pin No.		Name	Description	Applications Information
VSSOP-10	SOIC-14			
1	1	VCC	Positive supply input	Connect to system ground through a resistor. Connect a bypass capacitor to VEE. The voltage from VCC to VEE is nominally 13V set by an internal zener diode.
2	3	UVLO/EN	Under-voltage lockout	An external resistor divider from the system input voltage sets the under-voltage turn-on threshold. The enable threshold at the pin is 2.5V above VEE. An internal 22 $\mu$ A current source provides hysteresis. This pin can be used for remote enable and disable.
3	4	OVLO	Over-voltage lockout	An external resistor divider from the system input voltage sets the over-voltage turn-off threshold. The disable threshold at the pin is 2.5V above VEE. An internal 22 $\mu$ A current source provides hysteresis.
4	5	PWR	Power limit set	An external resistor at this pin, in conjunction with the current sense resistor ( $R_S$ ), sets the maximum power dissipation in the external series pass MOSFET.
5	6	VEE	Negative supply input	Connect to the system negative supply voltage (typically -48V).
6	8	TIMER	Timing capacitor	An external capacitor at this pin sets the insertion time delay and the fault timeout period. The capacitor also sets the restart timing of the LM5067-2.
7	9	SENSE	Current sense input	The voltage across the current sense resistor ( $R_S$ ) is measured from VEE to this pin. If the voltage across $R_S$ reaches 50 mV the load current is limited and the fault timer activates.
8	10	GATE	Gate drive output	Connect to the external N-channel MOSFET's gate.
9	12	OUT	Output feedback	Connect to the external MOSFET's drain. Internally used to determine the MOSFET $V_{DS}$ voltage for power limiting, and to control the PGD output pin.
10	14	PGD	Power Good indicator	An open drain output capable of sustaining 80V when off. When the external MOSFET $V_{DS}$ decreases below 1.23V the PGD pin switches high. When the external MOSFET $V_{DS}$ increases above $\approx 2.5V$ the PGD pin switches low.



These devices have limited built-in ESD protection. The leads should be shorted together or the device placed in conductive foam during storage or handling to prevent electrostatic damage to the MOS gates.

## Absolute Maximum Ratings <sup>(1)</sup>

Current into VCC (100 $\mu$ s pulse)	100 mA
OUT, PGD to VEE	-0.3V to 100V
UVLO, OVLO to VEE	-0.3V to 17V
SENSE to VEE	-0.3V to +0.3V
ESD Rating, Human Body Model <sup>(2)</sup>	2kV
Storage Temperature	-65°C to +150°C
Junction Temperature	+150°C

- (1) Absolute Maximum Ratings indicate limits beyond which damage to the device may occur. Operating Ratings indicate conditions for which the device is intended to be functional, but do not ensure specific performance limits. For specifications and conditions see the Electrical Characteristics.
- (2) The human body model is a 100 pF capacitor discharged through a 1.5 k $\Omega$  resistor into each pin.

## Operating Ratings

Current into VCC <sup>(1)</sup>	2 mA (min)
OUT Voltage above VEE	0V to 80V
PGD Off Voltage above VEE	0V to 80V
Junction Temperature	-40°C to +125°C

- (1) Maximum continuous current into VCC is limited by power dissipation and die temperature. See the Thermal Considerations section.

## Electrical Characteristics

Limits in standard type are for  $T_J = 25^\circ\text{C}$  only; limits in boldface type apply over the junction temperature ( $T_J$ ) range of  $-40^\circ\text{C}$  to  $+125^\circ\text{C}$ . Minimum and Maximum limits are specified through test, design, or statistical correlation. Typical values represent the most likely parametric norm at  $T_J = 25^\circ\text{C}$ , and are provided for reference purposes only. Unless otherwise stated the following conditions apply:  $I_{CC} = 2$  mA, OUT Pin = 48V above VEE, all voltages are with respect to VEE. See <sup>(1)</sup>.

Symbol	Parameter	Conditions	Min	Typ	Max	Unit
<b>Input</b>						
$V_Z$	Operating voltage, VCC – VEE	$I_{CC} = 2$ mA, UVLO = 5V	<b>12.3</b> <b>5</b>	13	<b>13.6</b> <b>5</b>	V
$I_{CC-EN}$	Internal operating current, enabled	VCC-VEE = 11V, UVLO = 5V		0.8	<b>1</b>	mA
$I_{CC-DIS}$	Internal operating current, disabled	VCC-VEE = 11V, UVLO = 2V		480	<b>660</b>	$\mu$ A
$POR_{IT}$	Threshold voltage to start insertion timer	VCC-VEE increasing		7.7	<b>8.2</b>	V
$POR_{EN}$	Threshold voltage to enable all functions	VCC-VEE increasing		8.4	<b>8.7</b>	V
$POR_{EN-HYS}$	$POR_{EN}$ hysteresis	VCC-VEE decreasing		125		mV
<b>OUT Pin</b>						
$I_{OUT-EN}$	OUT bias current, enabled	OUT = VEE, Normal operation		0.1		$\mu$ A
$I_{OUT-DIS}$	OUT bias current, disabled	Disabled, OUT = VEE + 48V		50		
<b>SENSE Pin</b>						
$I_{SNS-EN}$	SENSE bias current, enabled	OUT = VEE, Normal operation		-6		$\mu$ A
$I_{SNS-DIS}$	SENSE bias current, disabled	Disabled, OUT = VEE + 48V		-50		
<b>UVLO, OVLO Pins</b>						
$UVLO_{TH}$	UVLO threshold		<b>2.45</b>	2.5	<b>2.55</b>	V
$UVLO_{HYS}$	UVLO hysteresis current	UVLO = VEE + 2V	<b>10</b>	22	<b>34</b>	$\mu$ A
$UVLO_{DEL}$	UVLO delay	Delay to GATE high		26		$\mu$ s
		Delay to GATE low		12		$\mu$ s
$UVLO_{BIAS}$	UVLO bias current	UVLO = VEE + 5V			<b>1</b>	$\mu$ A
$OVLO_{TH}$	OVLO threshold		<b>2.43</b>	2.5	<b>2.57</b>	V
$OVLO_{HYS}$	OVLO hysteresis current	OVLO = VEE+2.8V	<b>-34</b>	-22	<b>-10</b>	$\mu$ A

- (1) Current out of a pin is indicated as a negative value.

## Electrical Characteristics (continued)

Limits in standard type are for  $T_J = 25^\circ\text{C}$  only; limits in boldface type apply over the junction temperature ( $T_J$ ) range of  $-40^\circ\text{C}$  to  $+125^\circ\text{C}$ . Minimum and Maximum limits are specified through test, design, or statistical correlation. Typical values represent the most likely parametric norm at  $T_J = 25^\circ\text{C}$ , and are provided for reference purposes only. Unless otherwise stated the following conditions apply:  $I_{CC} = 2\text{ mA}$ , OUT Pin = 48V above VEE, all voltages are with respect to VEE. See <sup>(1)</sup>.

Symbol	Parameter	Conditions	Min	Typ	Max	Unit
OVLO <sub>DEL</sub>	OVLO delay	Delay to GATE high		26		$\mu\text{s}$
		Delay to GATE low		12		$\mu\text{s}$
OVLO <sub>BIAS</sub>	OVLO bias current	OVLO = VEE + 2.4V			<b>1</b>	$\mu\text{A}$
<b>Gate Control (GATE Pin)</b>						
$I_{GATE}$	Source current	Normal Operation	<b>-72</b>	-52	<b>-32</b>	$\mu\text{A}$
		UVLO < 2.5V	<b>1.9</b>	2.2	<b>2.68</b>	mA
		SENSE - VEE = 150 mV or VCC - VEE < POR <sub>IT</sub> , $V_{GATE} = 5\text{V}$	<b>45</b>	110	<b>200</b>	
$V_{GATE}$	Gate output voltage in normal operation	GATE-VEE voltage		$V_Z$		V
<b>Current Limit</b>						
$V_{CL}$	Threshold voltage	SENSE - VEE voltage	<b>44</b>	50	<b>56</b>	mV
$t_{CL}$	Response time	SENSE - VEE stepped from 0 mV to 80 mV		25		$\mu\text{s}$
<b>Circuit Breaker</b>						
$V_{CB}$	Threshold voltage	SENSE - VEE voltage	<b>70</b>	100	<b>130</b>	mV
$t_{CB}$	Response time	SENSE - VEE stepped from 0 mV to 150 mV, time to GATE low, no load		0.65	<b>1.0</b>	$\mu\text{s}$
<b>Power Limit (PWR Pin)</b>						
PWR <sub>LIM</sub>	Power limit sense voltage (SENSE - VEE)	OUT - SENSE = 24V, $R_{PWR} = 75\text{ k}\Omega$	<b>16.5</b>	22	<b>27.5</b>	mV
$I_{PWR}$	PWR pin current	$V_{PWR} = 2.5\text{V}$		-23		$\mu\text{A}$
<b>Timer (TIMER Pin)</b>						
$V_{TMRH}$	Upper threshold		<b>3.76</b>	4	<b>4.16</b>	V
$V_{TMRL}$	Lower threshold	Restart cycles (LM5067-2)	<b>1.18</b>	1.25	<b>1.32</b>	V
		End of 8th cycle (LM5067-2)		0.3		V
		Re-enable threshold (LM5067-1)		0.3		V
$I_{TIMER}$	Insertion time current	TIMER pin = 2V	<b>-9.5</b>	-6	<b>-2.5</b>	$\mu\text{A}$
	Sink current, end of insertion time	TIMER pin = 2V	<b>1.2</b>	1.55	<b>1.9</b>	mA
	Fault detection current	TIMER pin = 2V	<b>-140</b>	-85	<b>-44</b>	$\mu\text{A}$
	Sink current, end of fault time		<b>0.9</b>	2.5	<b>4.25</b>	$\mu\text{A}$
DC <sub>FAULT</sub>	Fault Restart Duty Cycle	LM5067-2		0.5		%
$t_{FAULT}$	Fault to GATE low delay	TIMER pin reaches 4.0V		15		$\mu\text{s}$
<b>Power Good (PGD Pin)</b>						
PGD <sub>TH</sub>	Threshold measured at OUT - SENSE	Decreasing	<b>1.16</b> <b>2</b>	1.23	<b>1.28</b> <b>5</b>	V
		Increasing, relative to decreasing threshold	<b>1.14</b> <b>3</b>	1.25	<b>1.32</b> <b>5</b>	
PGD <sub>VOL</sub>	Output low voltage	$I_{SINK} = 2\text{ mA}$		60	<b>150</b>	mV
PGD <sub>IOH</sub>	Off leakage current	$V_{PGD} = 80\text{V}$			<b>5</b>	$\mu\text{A}$
<b>Thermal Resistance<sup>(2)</sup></b>						
$\theta_{JA}$	Junction to Ambient	VSSOP package		94		$^\circ\text{C/W}$
$\theta_{JC}$	Junction to Case	VSSOP package		44		$^\circ\text{C/W}$
$\theta_{JA}$	Junction to Ambient	SOIC-14 Package		90		$^\circ\text{C/W}$

(2) Tested on a 4 layer JEDEC board with 2 vias under the package. See JEDEC standards JESD51-7 and JESD51-3. See the Thermal Considerations section.

### Electrical Characteristics (continued)

Limits in standard type are for  $T_J = 25^\circ\text{C}$  only; limits in boldface type apply over the junction temperature ( $T_J$ ) range of  $-40^\circ\text{C}$  to  $+125^\circ\text{C}$ . Minimum and Maximum limits are specified through test, design, or statistical correlation. Typical values represent the most likely parametric norm at  $T_J = 25^\circ\text{C}$ , and are provided for reference purposes only. Unless otherwise stated the following conditions apply:  $I_{CC} = 2\text{ mA}$ , OUT Pin = 48V above VEE, all voltages are with respect to VEE. See <sup>(1)</sup>.

Symbol	Parameter	Conditions	Min	Typ	Max	Unit
$\theta_{JC}$	Junction to Case	SOIC-14 Package		27		$^\circ\text{C/W}$

### Typical Performance Characteristics

Unless otherwise specified the following conditions apply:  $T_J = 25^\circ\text{C}$ .

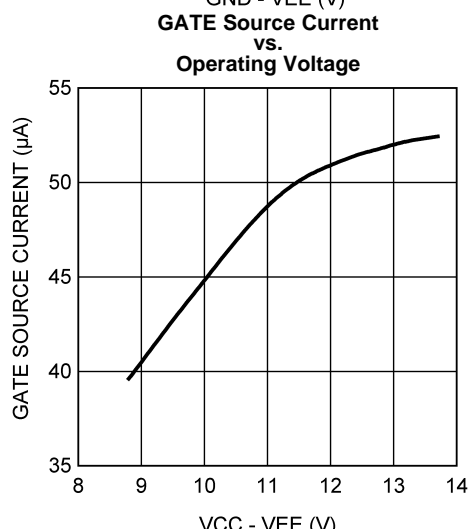
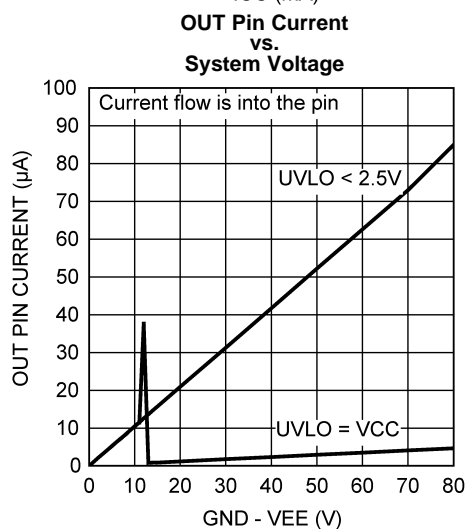
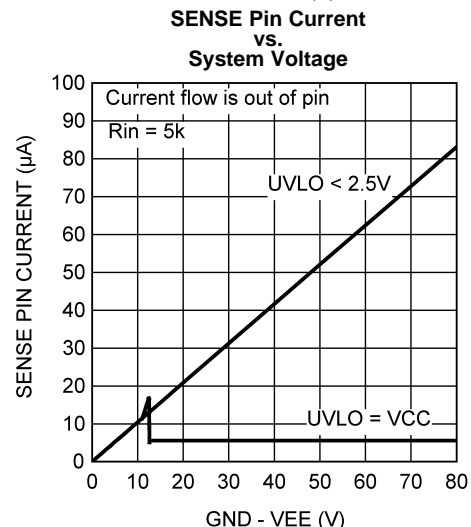
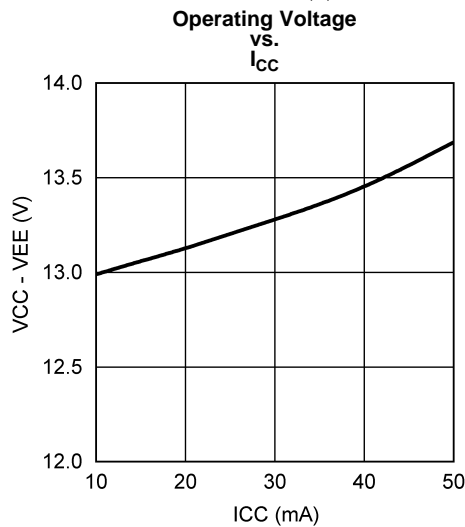
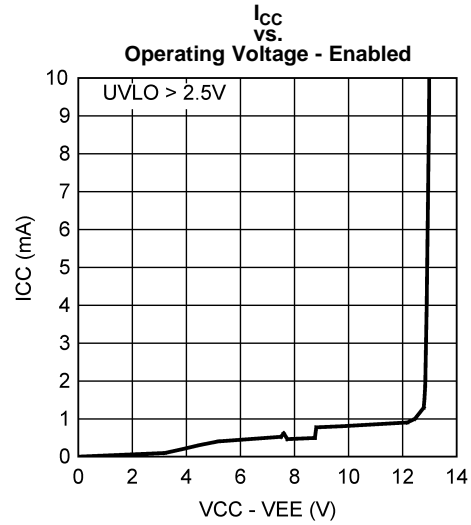
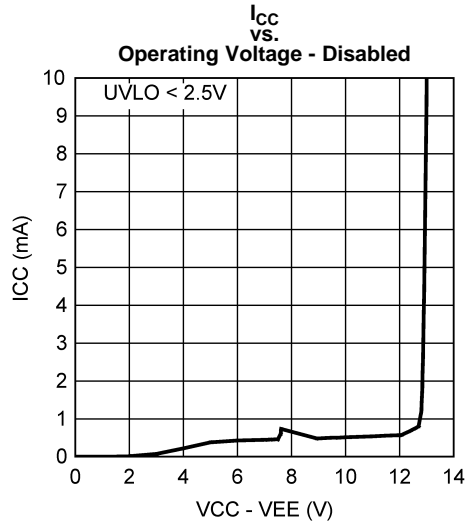

Typical Performance Characteristics (continued)

Unless otherwise specified the following conditions apply:  $T_J = 25^\circ\text{C}$ .

GATE Pull-Down Current, Circuit Breaker vs. GATE Voltage

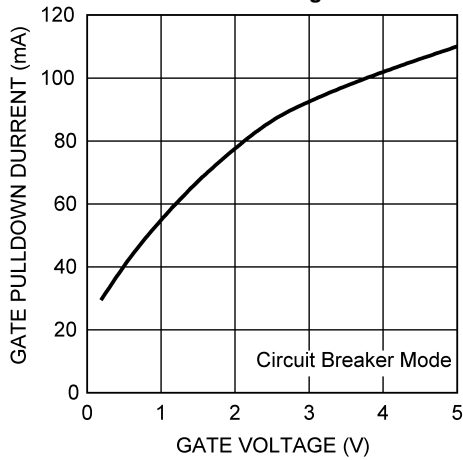

PGD Low Voltage vs. Sink Current

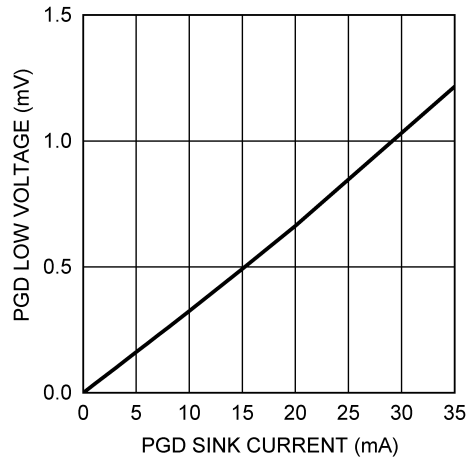

MOSFET Power Dissipation Limit vs.  $R_{PWR}$  and  $R_S$

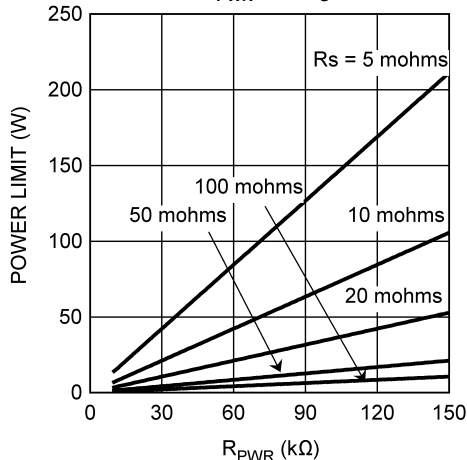

UVLO & OVLO Hysteresis Current vs. Temperature

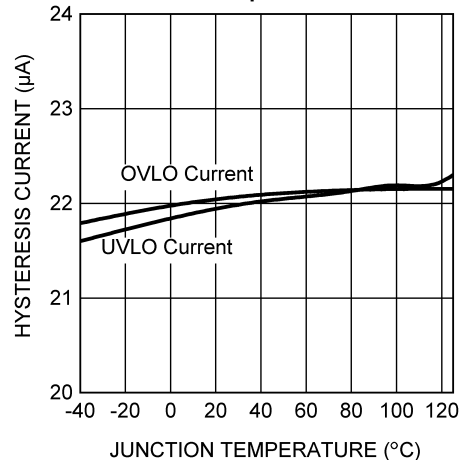

UVLO, OVLO Threshold Voltage vs. Temperature

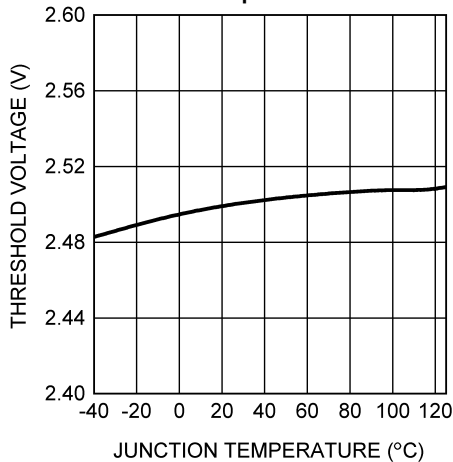

$V_Z$  Operating Voltage vs. Temperature

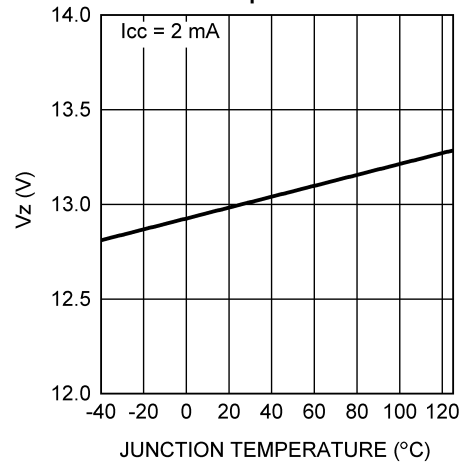

**Typical Performance Characteristics (continued)**

Unless otherwise specified the following conditions apply:  $T_J = 25^\circ\text{C}$ .

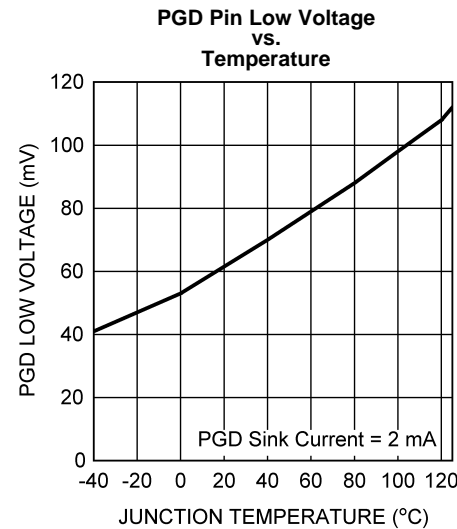
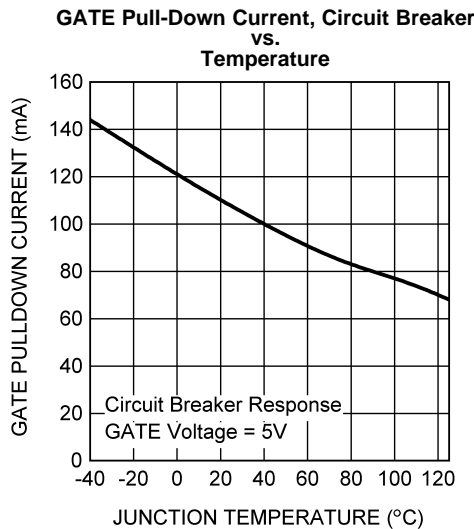
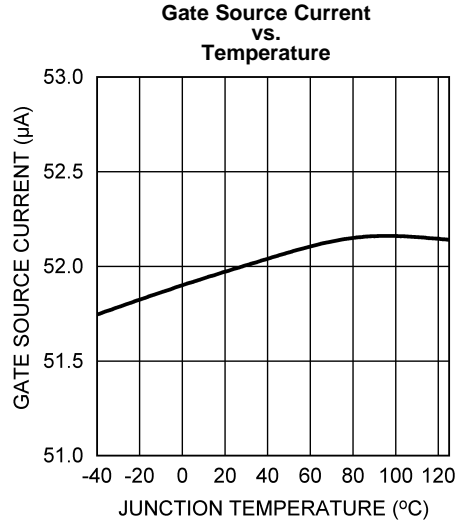
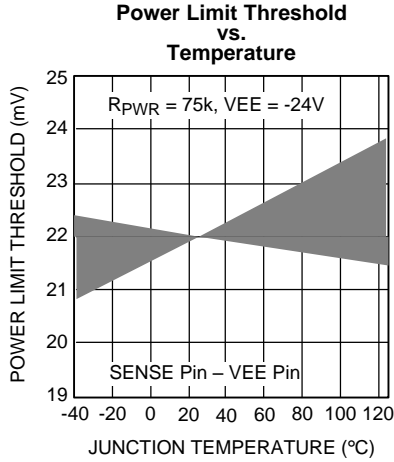
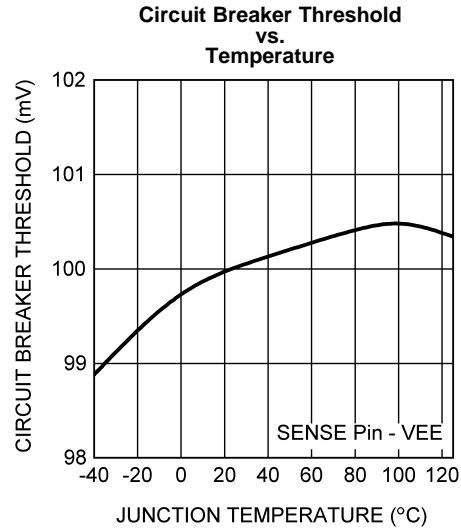
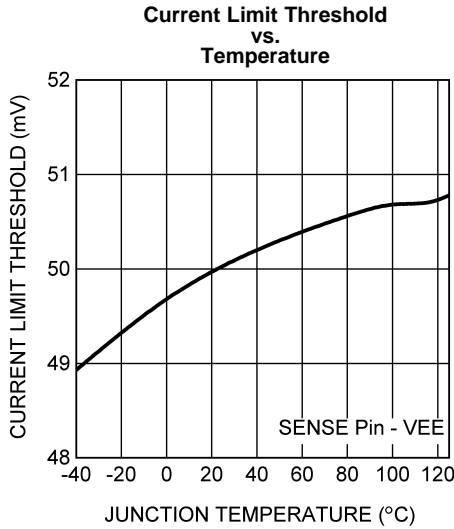

### Typical Performance Characteristics (continued)

Unless otherwise specified the following conditions apply:  $T_J = 25^\circ\text{C}$ .

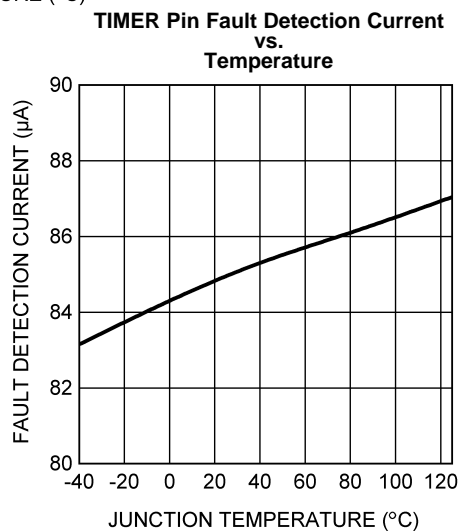
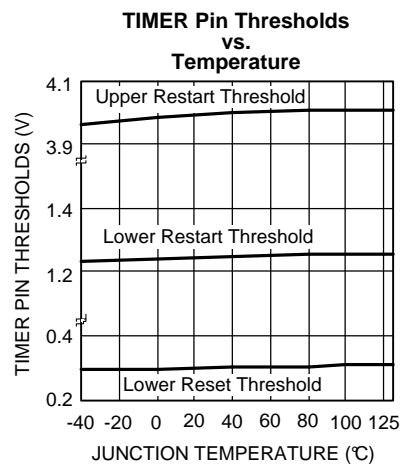
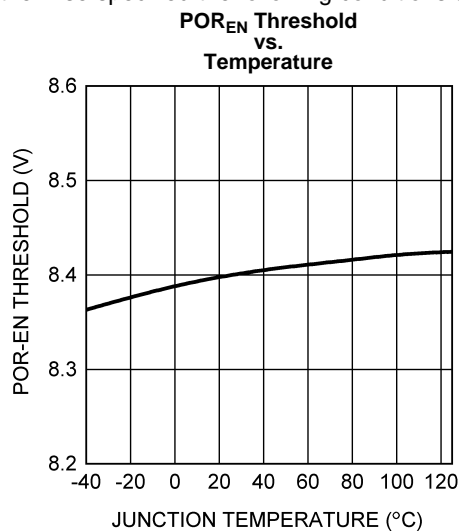

BLOCK DIAGRAM

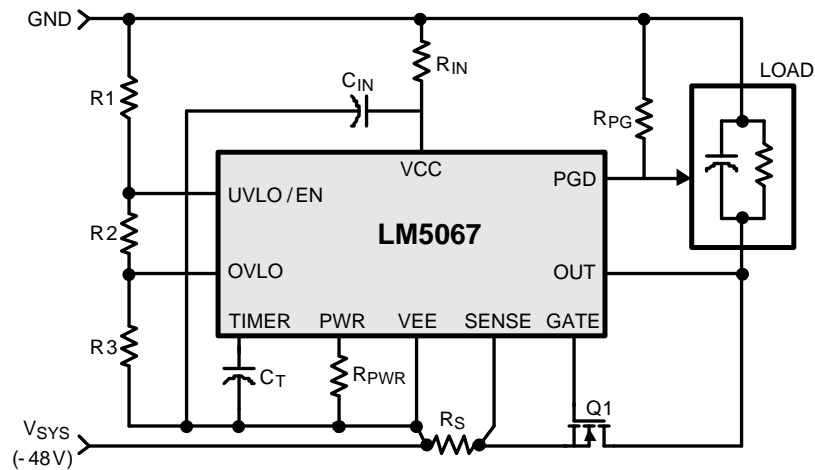
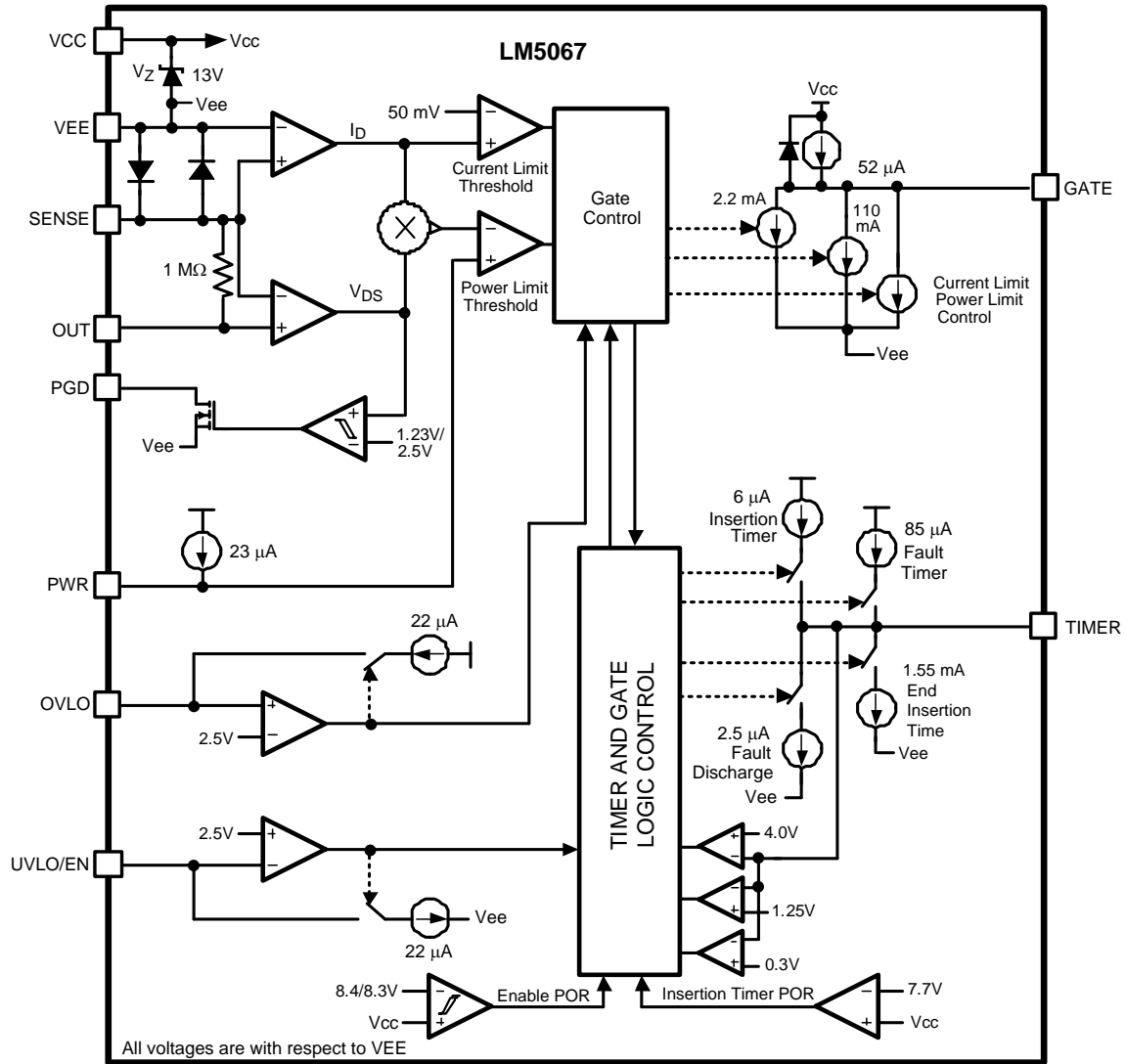

Figure 4. Basic Application Circuit

## FUNCTIONAL DESCRIPTION

The LM5067 is designed to control the in-rush current to the load upon insertion of a circuit card into a live backplane or other “hot” power source, thereby limiting the voltage sag on the backplane’s supply voltage, and the  $dV/dt$  of the voltage applied to the load. Effects on other circuits in the system are minimized, preventing possible unintended resets. During the system power up, the maximum power dissipation in the series pass device is limited to a safe value within the device’s Safe Operating Area (SOA). After the system power up is complete, the LM5067 monitors the load for excessive currents due to a fault or short circuit at the load. Limiting the load current and/or the power in the external MOSFET for an extended period of time results in the shutdown of the series pass MOSFET. After a fault event, the LM5067-1 latches off until the circuit is re-enabled by external control, while the LM5067-2 automatically restarts with defined timing. The circuit breaker function quickly switches off the series pass device upon detection of a severe over-current condition caused by, e.g. a short circuit at the load. The Power Good (PGD) output pin indicates when the output voltage is close to the normal operating value. Programmable under-voltage lock-out (UVLO) and over-voltage lock-out (OVLO) circuits shut down the LM5067 when the system input voltage is outside the desired operating range. The typical configuration of a circuit card with LM5067 hot swap protection is shown in Figure 5.

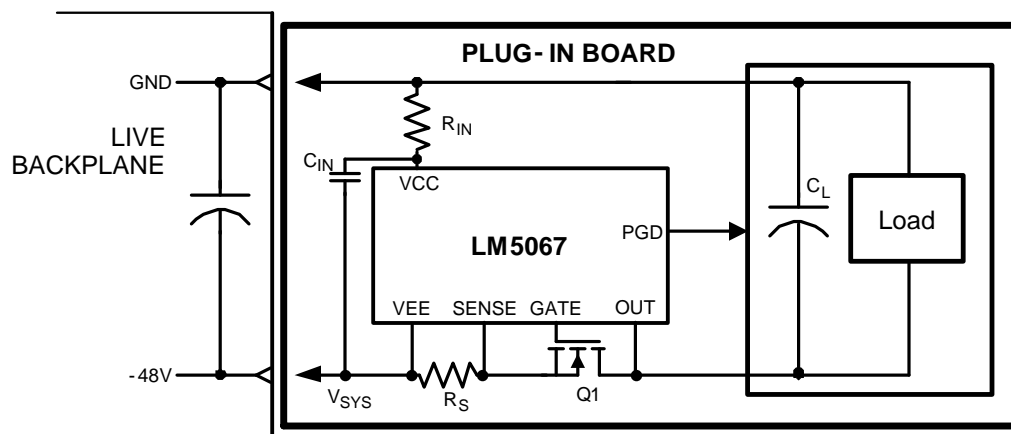

Figure 5. LM5067 Application

The LM5067 can be used in a variety of applications, other than plug-in boards, to monitor for excessive load current, provide transient protection, and ensuring the voltage to the load is within preferred limits. The circuit breaker function protects the system from a sudden short circuit at the load. Use of the UVLO/EN pin allows the LM5067 to be used as a solid state relay. The PGD output provides a status indication of the voltage at the load relative to the input system voltage.

### Power Up Sequence

The system voltage range of the LM5067 is -9V to -80V, with a transient capability to -100V. Referring to the Block Diagram, Figure 4, and Figure 6, as the system voltage ( $V_{SYS}$ ) initially increases from zero, the external N-channel MOSFET (Q1) is held off by an internal 110 mA pull-down current at the GATE pin. The strong pull-down current at the GATE pin prevents an inadvertent turn-on as the MOSFET’s gate-to-drain (Miller) capacitance is charged. When the operating voltage of the LM5067 ( $V_{CC} - V_{EE}$ ) reaches the  $POR_{IT}$  threshold (7.7V) the insertion timer starts. During the insertion time, the capacitor at the TIMER pin ( $C_T$ ) is charged by a 6  $\mu A$  current source, and Q1 is held off by a 2.2 mA pull-down current at the GATE pin regardless of the system voltage. The insertion time delay allows ringing and transients at  $V_{SYS}$  to settle before Q1 can be enabled. The insertion time ends when the TIMER pin voltage reaches 4.0V above VEE, and  $C_T$  is then quickly discharged by an internal 1.5 mA pull-down current. After the insertion time, the LM5067 control circuitry is enabled when the operating voltage reaches the  $POR_{EN}$  threshold (8.4V). As  $V_{SYS}$  continues to increase, the LM5067 operating voltage is limited at  $\approx 13V$  by an internal zener diode. The remainder of the system voltage is dropped across the input resistor  $R_{IN}$ .

The GATE pin switches on Q1 when  $V_{SYS}$  exceeds the UVLO threshold (UVLO pin  $>2.5V$  above VEE). If  $V_{SYS}$  exceeds the UVLO threshold at the end of the insertion time, Q1 is switched on at that time. The GATE pin sources  $52 \mu A$  to charge Q1's gate capacitance. The maximum gate-to-source voltage of Q1 is limited by the LM5067's operating voltage ( $V_Z$ ) to approximately 13V. During power up, as the voltage at the OUT pin increases in magnitude with respect to Ground, the LM5067 monitors Q1's drain current and power dissipation. In-rush current limiting and/or power limiting circuits actively control the current delivered to the load. During the in-rush limiting interval ( $t_2$  in Figure 6) an internal current source charges  $C_T$  at the TIMER pin. When the load current reduces from the limiting value to a value determined by the load the in-rush limiting interval is complete and  $C_T$  is discharged. The PGD pin switches high when the voltage at the OUT pin reaches to within 1.25V of the voltage at the SENSE pin.

If the TIMER pin voltage reaches 4.0V before in-rush current limiting or power limiting ceases (during  $t_2$ ), a fault is declared and Q1 is turned off. See [Fault Timer and Restart](#) for a complete description of the fault mode.

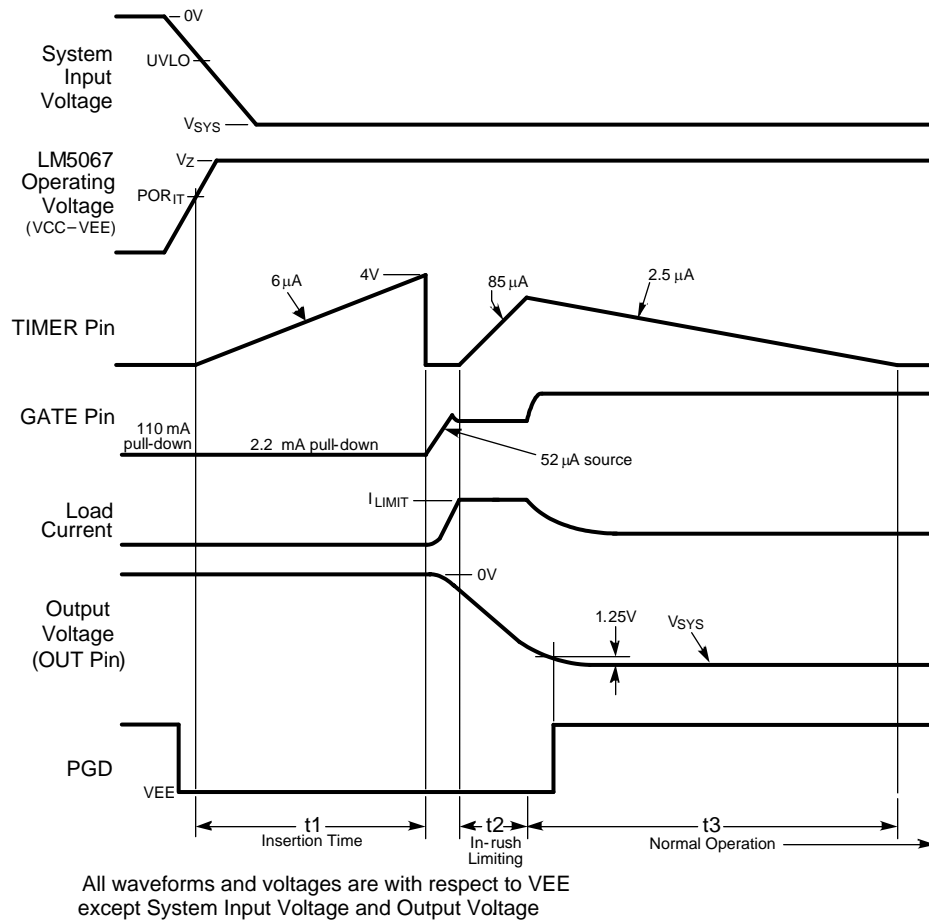

**Figure 6. Power Up Sequence (Current Limit only)**

## Operating Voltage

The LM5067 operating voltage is the voltage from VCC to VEE. The maximum operating voltage is set by an internal 13V zener diode. With the IC connected as shown in Figure 4, the LM5067 controller operates in the voltage range between VEE and VEE+13V. The remainder of the system voltage is dropped across the input resistor  $R_{IN}$ , which must be selected to pass at least 2 mA into the LM5067 at the minimum system voltage.



## Circuit Breaker

If the load current increases rapidly (e.g., the load is short-circuited) the current in the sense resistor ( $R_S$ ) may exceed the current limit threshold before the current limit control loop is able to respond. If the current exceeds approximately twice the current limit threshold ( $100\text{ mV}/R_S$ ), Q1's gate is quickly pulled down by the 110 mA pull-down current at the GATE pin, and a Fault Timeout Period begins. When the voltage across  $R_S$  falls below 100 mV the 110 mA pull-down current at the GATE pin is switched off, and the gate voltage of Q1 is then determined by the current limit or the power limit functions. If the TIMER pin reaches 4.0V before the current limiting or power limiting condition ceases, Q1 is switched off by the 2.2 mA pull-down current at the GATE pin as described in the Fault Timer & Restart section.

## Power Limit

An important feature of the LM5067 is the MOSFET power limiting. The Power Limit function can be used to maintain the maximum power dissipation of MOSFET Q1 within the device SOA rating. The LM5067 determines the power dissipation in Q1 by monitoring its drain-source voltage (OUT to SENSE), and the drain current through the sense resistor (SENSE to VEE). The product of the current and voltage is compared to the power limit threshold programmed by the resistor at the PWR pin. If the power dissipation reaches the limiting threshold, the GATE voltage is modulated to reduce the current in Q1, and the fault timer is active as described in the Fault Timer & Restart section.

## Fault Timer and Restart

When the current limit or power limit threshold is reached during turn-on or as a result of a fault condition, the gate-to-source voltage of Q1 is modulated to regulate the load current and power dissipation in Q1. When either limiting function is active, an 85  $\mu\text{A}$  fault timer current source charges the external capacitor ( $C_T$ ) at the TIMER pin as shown in [Figure 9](#) (Fault Timeout Period). If the fault condition subsides before the TIMER pin reaches 4.0V, the LM5067 returns to the normal operating mode and  $C_T$  is discharged by the 2.5  $\mu\text{A}$  current sink. If the TIMER pin reaches 4.0V during the Fault Timeout Period, Q1 is switched off by a 2.2 mA pull-down current at the GATE pin. The subsequent restart procedure depends on which version of the LM5067 is in use.

The LM5067-1 latches the GATE pin low at the end of the Fault Timeout Period, and  $C_T$  is discharged by the 2.5  $\mu\text{A}$  fault current sink. The GATE pin is held low until a power up sequence is externally initiated by cycling the input voltage ( $V_{SYS}$ ), or momentarily pulling the UVLO/EN pin within 2.5V of VEE with an open-collector or open-drain device as shown in [Figure 8](#). The voltage across  $C_T$  must be  $<0.3\text{V}$  for the restart procedure to be effective.

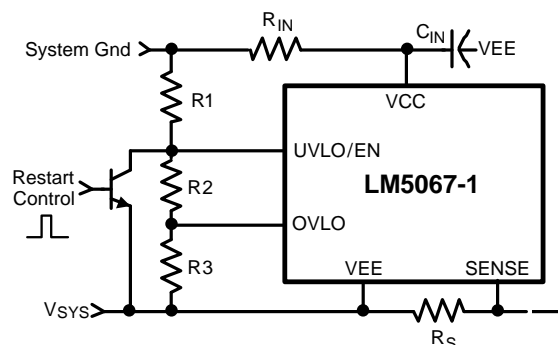

**Figure 8. Latched Fault Restart Control**

The LM5067-2 provides an automatic restart sequence which consists of the TIMER pin cycling between 4.0V and 1.25V seven times after the Fault Timeout Period, as shown in [Figure 9](#). The period of each cycle is determined by the 85  $\mu\text{A}$  charging current, and the 2.5  $\mu\text{A}$  discharge current, and the value of the capacitor  $C_T$ . When the TIMER pin reaches 0.3V during the eighth high-to-low ramp, the 52  $\mu\text{A}$  current source at the GATE pin turns on Q1. If the fault condition is still present, the Fault Timeout Period and the restart cycle repeat.

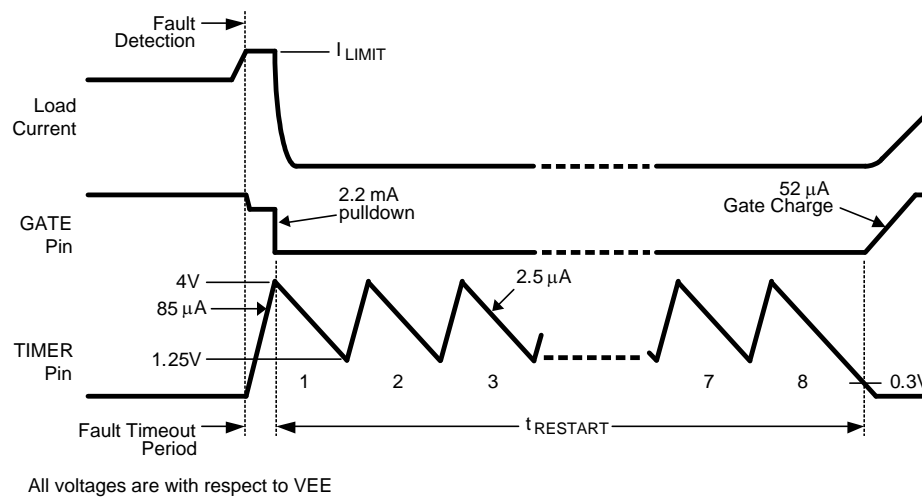

Figure 9. Restart Sequence (LM5067-2)

### Under-Voltage Lock-Out (UVLO)

The series pass MOSFET (Q1) is enabled when the input supply voltage ( $V_{SYS}$ ) is within the operating range defined by the programmable under-voltage lockout (UVLO) and over-voltage lock-out (OVLO) levels. Typically the UVLO level at  $V_{SYS}$  is set with a resistor divider (R1-R3) as shown in Figure 4. When  $V_{SYS}$  is less than the UVLO level, the internal 22  $\mu$ A current sink at UVLO/EN is enabled, the current source at OVLO is off, and Q1 is held off by the 2.2 mA pull-down current at the GATE pin.  $V_{SYS}$  reaches its UVLO level when the voltage at the UVLO/EN pin reaches 2.5V above VEE. Upon reaching the UVLO level, the 22  $\mu$ A current sink at the UVLO/EN pin is switched off, increasing the voltage at the pin, providing hysteresis for this threshold. With the UVLO/EN pin above 2.5V, Q1 is switched on by the 52  $\mu$ A current source at the GATE pin.

See Application Information for a procedure to calculate the values of the threshold setting resistors (R1-R3). The minimum possible UVLO level can be set by connecting the UVLO/EN pin to VCC. In this case Q1 is enabled when the operating voltage ( $VCC - VEE$ ) reaches the  $POR_{EN}$  threshold (8.4V).

### Over-Voltage Lock-Out (OVLO)

The series pass MOSFET (Q1) is enabled when the input supply voltage ( $V_{SYS}$ ) is within the operating range defined by the programmable under-voltage lockout (UVLO) and over-voltage lock-out (OVLO) levels. Typically the OVLO level at  $V_{SYS}$  is set with a resistor divider (R1-R3) as shown in Figure 4. If  $V_{SYS}$  raises the OVLO pin voltage more than 2.5V above VEE Q1 is switched off by the 2.2 mA pull-down current at the GATE pin, denying power to the load. When the OVLO pin is above 2.5V, the internal 22  $\mu$ A current source at OVLO is switched on, raising the voltage at OVLO and providing threshold hysteresis. When the voltage at the OVLO pin is reduced below 2.5V the 22  $\mu$ A current source is switched off, and Q1 is enabled. See Application Information for a procedure to calculate the threshold setting resistor values.

### Shutdown/Enable Control

See Application Information for a description of how to use the UVLO/EN pin and/or the OVLO pin for remote shutdown and enable control of the LM5067.

### Power Good Pin

The Power Good output indicator pin (PGD) is connected to the drain of an internal N-channel MOSFET. An external pull-up resistor is required at PGD to an appropriate voltage to indicate the status to downstream circuitry. The off-state voltage at the PGD pin must be more positive than VEE, and can be up to 80V above VEE with transient capability to 100V. PGD is switched high at the end of the turn-on sequence when the voltage from OUT to SENSE (the external MOSFET's  $V_{DS}$ ) decreases below 1.23V. PGD switches low if the MOSFET's  $V_{DS}$  increases past 2.5V, if the system input voltage goes below the UVLO threshold or above the OVLO threshold, or if a fault is detected. The PGD output is high when the operating voltage ( $VCC-V_{EE}$ ) is less than 2V.

## APPLICATION INFORMATION (REFER TO FIGURE 4)

### $R_{IN}$ , $C_{IN}$

The LM5067 operating voltage is determined by an internal 13V shunt regulator which receives its current from the system voltage via  $R_{IN}$ . When the system voltage exceeds 13V, the LM5067 operating voltage ( $V_{CC} - V_{EE}$ ) is between  $V_{EE}$  and  $V_{EE}+13V$ . The remainder of the system voltage is dropped across the input resistor  $R_{IN}$ , which must be selected to pass at least 2 mA into the LM5067 at the minimum system voltage. The resistor's power rating must be selected based on the power dissipation at maximum system voltage, calculated from:

$$P_{RIN} = (V_{SYS(max)} - 13V)^2/R_{IN} \quad (1)$$

### CURRENT LIMIT, $R_S$

The LM5067 monitors the current in the external MOSFET (Q1) by measuring the voltage across the sense resistor ( $R_S$ ), connected from SENSE to VEE. The required resistor value is calculated from:

$$R_S = \frac{50 \text{ mV}}{I_{LIM}}$$

where

- $I_{LIM}$  is the desired current limit threshold (2)

When the voltage across  $R_S$  reaches 50 mV, the current limit circuit modulates the gate of Q1 to regulate the current at  $I_{LIM}$ . While the current limiting circuit is active, the fault timer is active as described in the Fault Timer & Restart section. For proper operation,  $R_S$  must be no larger than 100 m $\Omega$ .

While the maximum load current in normal operation can be used to determine the required power rating for resistor  $R_S$ , basing it on the current limit value provides a more reliable design since the circuit can operate near the current limit threshold continuously. The resistor's surge capability must also be considered since the circuit breaker threshold is approximately twice the current limit threshold. Connections from  $R_S$  to the LM5067 should be made using Kelvin techniques. In the suggested layout of Figure 10 the small pads at the upper corners of the sense resistor connect only to the sense resistor terminals, and not to the traces carrying the high current. With this technique, only the voltage across the sense resistor is applied to VEE and SENSE, eliminating the voltage drop across the high current solder connections.

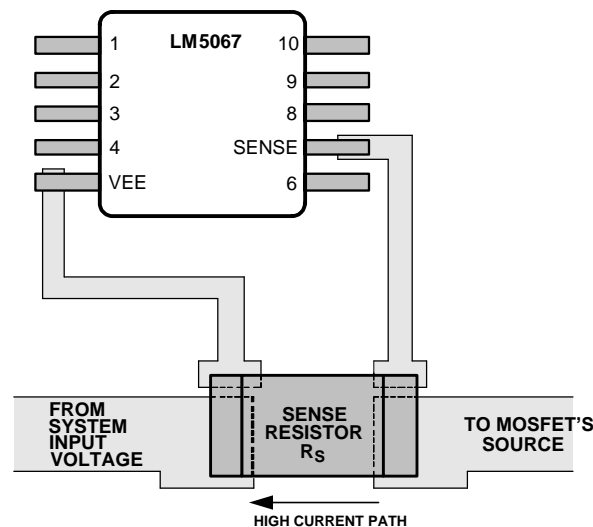

**Figure 10. Sense Resistor Connections**

### POWER LIMIT THRESHOLD

The LM5067 determines the power dissipation in the external MOSFET (Q1) by monitoring the drain current (the current in  $R_S$ ), and the  $V_{DS}$  of Q1 (OUT to SENSE pins). The resistor at the PWR pin ( $R_{PWR}$ ) sets the maximum power dissipation for Q1, and is calculated from the following equation:

$$R_{PWR} = 1.42 \times 10^5 \times R_S \times P_{FET(LIM)}$$

where

- $P_{FET(LIM)}$  is the desired power limit threshold for Q1
  - $R_S$  is the current sense resistor described in the Current Limit section
- (3)

For example, if  $R_S$  is 10 mΩ, and the desired power limit threshold is 60W,  $R_{PWR}$  calculates to 85.2 kΩ. If Q1's power dissipation reaches the power limit threshold, Q1's gate is modulated to control the load current, keeping Q1's power from exceeding the threshold. For proper operation of the power limiting feature,  $R_{PWR}$  must be ≤150 kΩ. While the power limiting circuit is active, the fault timer is active as described in the Fault Timer & Restart section. Typically, power limit is reached during startup, or when the  $V_{DS}$  of Q1 increases due to a severe overload or short circuit.

The programmed maximum power dissipation should have a reasonable margin relative to the maximum power defined by the SOA chart if the LM5067-2 is used since the FET will be repeatedly stressed during fault restart cycles. The FET manufacturer should be consulted for guidelines. The PWR pin can be left open if the application does not require use of the power limit function.

## TURN-ON TIME

The output turn-on time depends on whether the LM5067 operates in current limit only, or in both power limit and current limit, during turn-on.

**A) Turn-on with current limit only:** If the current limit threshold is less than the current defined by the power limit threshold at maximum  $V_{DS}$  the circuit operates only at the current limit threshold during turn-on. Referring to Figure 13a, as the drain current reaches  $I_{LIM}$ , the gate-to-source voltage is controlled at  $V_{GSL}$  to maintain the current at  $I_{LIM}$ . As the output voltage reaches its final value ( $V_{DS} \approx 0V$ ) the drain current reduces to the value defined by the load, and the gate is charged to approximately 13V ( $V_{GATE}$ ). The time for the OUT pin voltage to transition from zero volts to  $V_{SYS}$  is equal to:

$$t_{ON} = \frac{V_{SYS} \times C_L}{I_{LIM}}$$

where

- $C_L$  is the load capacitance
- (4)

For example, if  $V_{SYS} = -48V$ ,  $C_L = 1000 \mu F$ , and  $I_{LIM} = 1A$ ,  $t_{ON}$  calculates to 48 ms. The maximum instantaneous power dissipated in the MOSFET is 48W. This calculation assumes the time from t1 to t2 in Figure 13a is small compared to  $t_{ON}$ , and the load does not draw any current until after the output voltage has reached its final value, and PGD switches high (Figure 11).

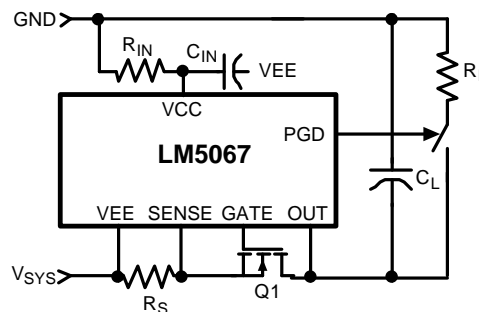

Figure 11. No Load Current During Turn-on

If the load draws current during the turn-on sequence (Figure 12), the turn-on time is longer than the above calculation, and is approximately equal to:

$$t_{ON} = -(R_L \times C_L) \times \ln \left[ \frac{(I_{LIM} \times R_L) - V_{SYS}}{(I_{LIM} \times R_L)} \right]$$

where

- $R_L$  is the load resistance and  $V_{SYS}$  is the absolute value of the system input voltage (5)

**The Fault Timeout Period must be set longer than  $t_{ON}$  to prevent a fault shutdown before the turn-on sequence is complete.**

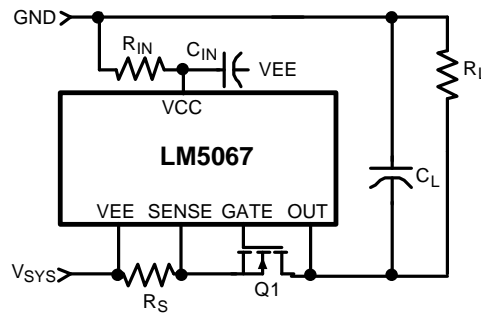
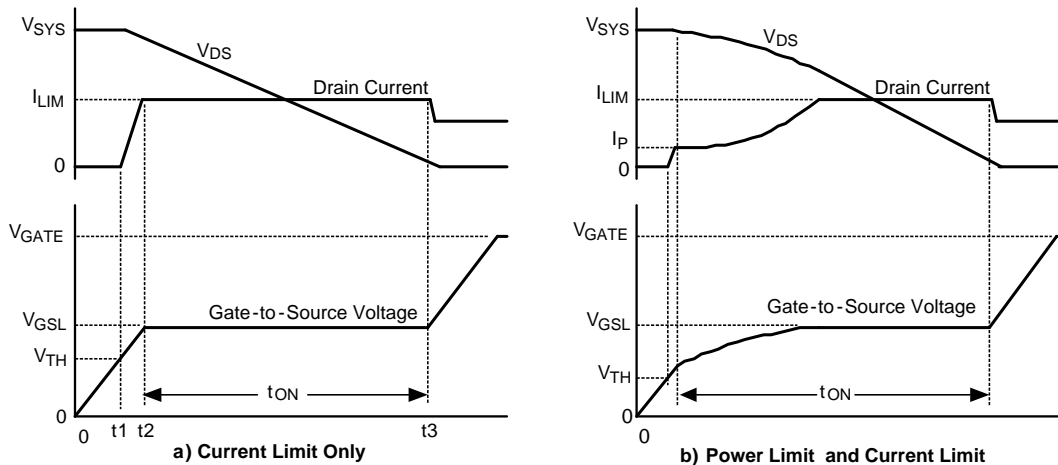

**Figure 12. Load Draws Current During Turn-On**

**B) Turn-on with power limit and current limit:** The power dissipation limit in Q1 ( $P_{FET(LIM)}$ ) is defined by the resistor at the PWR pin, and the current sense resistor  $R_S$ . See [POWER LIMIT THRESHOLD](#). If the current limit threshold ( $I_{LIM}$ ) is higher than the current defined by the power limit threshold at maximum  $V_{DS}$  ( $P_{FET(LIM)}/V_{SYS}$ ) the circuit operates initially in power limit mode when the  $V_{DS}$  of Q1 is high, and then transitions to current limit mode as the current increases to  $I_{LIM}$  as  $V_{DS}$  decreases. See [Figure 13b](#). Assuming the load ( $R_L$ ) is not connected during turn-on, the time for the output voltage to reach its final value is approximately equal to:

$$t_{ON} = \frac{C_L \times V_{SYS}^2}{2 \times P_{FET(LIM)}} + \frac{C_L \times P_{FET(LIM)}}{2 \times I_{LIM}^2} \quad (6)$$

For example, if  $V_{SYS} = -48V$ ,  $C_L = 1000 \mu F$ ,  $I_{LIM} = 1A$ , and  $P_{FET(LIM)} = 20W$ ,  $t_{ON}$  calculates to  $\approx 68$  ms, and the initial current level ( $I_p$ ) is approximately 0.42A. **The Fault Timeout Period must be set longer than  $t_{ON}$ .**



**Figure 13. MOSFET Power Up Waveforms**

## MOSFET SELECTION

It is recommended that the external MOSFET (Q1) selection be based on the following criteria:

- The  $BV_{DSS}$  rating should be greater than the maximum system voltage ( $V_{SYS}$ ), plus ringing and transients which can occur at  $V_{SYS}$  when the circuit card, or adjacent cards, are inserted or removed.
- The maximum continuous current rating should be based on the current limit threshold ( $50 \text{ mV}/R_S$ ), not the maximum load current, since the circuit can operate near the current limit threshold continuously.
- The Pulsed Drain Current spec ( $I_{DM}$ ) must be greater than the current threshold for the circuit breaker function ( $100 \text{ mV}/R_S$ ).

- The SOA (Safe Operating Area) chart of the device, and the thermal properties, should be used to determine the maximum power dissipation threshold set by the  $R_{PWR}$  resistor. The programmed maximum power dissipation should have a reasonable margin from the maximum power defined by the FET's SOA chart if the LM5067-2 is used since the FET will be repeatedly stressed during fault restart cycles. The FET manufacturer should be consulted for guidelines.
- $R_{DS(on)}$  should be sufficiently low that the power dissipation at maximum load current ( $I_{L(max)}^2 \times R_{DS(on)}$ ) does not raise its junction temperature above the manufacturer's recommendation.

If the device chosen for Q1 has a maximum  $V_{GS}$  rating less than 13V, an external zener diode must be added from its gate to source, with the zener voltage less than the maximum  $V_{GS}$  rating. The zener diode's forward current rating must be at least 110 mA to conduct the GATE pull-down current during startup and in the circuit breaker mode.

## TIMER CAPACITOR, $C_T$

The TIMER pin capacitor ( $C_T$ ) sets the timing for the insertion time delay, fault timeout period, and restart timing of the LM5067-2.

**A) Insertion Delay** - Upon applying the system voltage ( $V_{SYS}$ ) to the circuit, the external MOSFET (Q1) is held off during the insertion time ( $t_1$  in [Figure 6](#)) to allow ringing and transients at  $V_{SYS}$  to settle. Since each backplane's response to a circuit card plug-in is unique, the worst case settling time must be determined for each application. The insertion time starts when the operating voltage (VCC-VEE) reaches the  $POR_T$  threshold, at which time the internal 6  $\mu A$  current source charges  $C_T$  from 0V to 4.0V. The required capacitor value is calculated from:

$$C_T = \frac{t_1 \times 6 \mu A}{4V} = t_1 \times 1.5 \times 10^{-6}$$

where

- $t_1$  is the desired insertion delay (7)

For example, if the desired insertion delay is 250 ms,  $C_T$  calculates to 0.38  $\mu F$ . At the end of the insertion delay,  $C_T$  is quickly discharged by a 1.5 mA current sink.

**B) Fault Timeout Period** - During turn-on of the output voltage, or upon detection of a fault condition where the current limit and/or power limit circuits regulate the current through Q1,  $C_T$  is charged by the fault timer current source (85  $\mu A$ ). The Fault Timeout Period is the time required for the TIMER pin voltage to reach 4.0V above VEE, at which time Q1 is switched off. The required capacitor value for the desired Fault Timeout Period  $t_{FAULT}$  is calculated from:

$$C_T = \frac{t_{FAULT} \times 85 \mu A}{4V} = t_{FAULT} \times 2.13 \times 10^{-5} \quad (8)$$

For example, if the desired Fault Timeout Period is 16 ms,  $C_T$  calculates to 0.34  $\mu F$ . After a fault timeout, if the LM5067-1 is in use,  $C_T$  must be allowed to discharge to <0.3V by the 2.5  $\mu A$  current sink, after which a power up sequence can be initiated by external circuitry. See [Fault Timer and Restart](#) and [Figure 8](#). If the LM5067-2 is in use, after the Fault Timeout Period expires a restart sequence begins as described below (Restart Timing).

Since the LM5067 normally operates in power limit and/or current limit during a power up sequence, the Fault Timeout Period **MUST** be longer than the time required for the output voltage to reach its final value. See [TURN-ON TIME](#).

**C) Restart Timing** If the LM5067-2 is in use, after the Fault Timeout Period described above,  $C_T$  is discharged by the 2.5  $\mu A$  current sink to 1.25V. The TIMER pin then cycles through seven additional charge/discharge cycles between 1.25V and 4.0V as shown in [Figure 9](#). The restart time ends when the TIMER pin voltage reaches 0.3V during the final high-to-low ramp. The restart time, after the Fault Timeout Period, is equal to:

$$t_{RESTART} = C_T \times \left[ \frac{7 \times 2.75V}{2.5 \mu A} + \frac{7 \times 2.75V}{85 \mu A} + \frac{3.7V}{2.5 \mu A} \right]$$

$$= C_T \times 9.4 \times 10^6 \quad (9)$$

For example, if  $C_T = 0.33 \mu\text{F}$ ,  $t_{\text{RESTART}} = 3.1$  seconds. At the end of the restart time, Q1 is switched on. If the fault is still present, the fault timeout and restart sequence repeats. The on-time duty cycle of Q1 is approximately 0.5% in this mode.

## UVLO, OVLO

By programming the UVLO and OVLO thresholds the LM5067 enables the series pass device (Q1) when the input supply voltage ( $V_{\text{SYS}}$ ) is within the desired operational range. If  $V_{\text{SYS}}$  is below the UVLO threshold, or above the OVLO threshold, Q1 is switched off, denying power to the load. Hysteresis is provided for each threshold.

### NOTE

All voltages are with respect to Vee in the discussions below. Use absolute values in the equations.

**Option A:** The configuration shown in [Figure 14](#) requires three resistors (R1-R3) to set the thresholds.

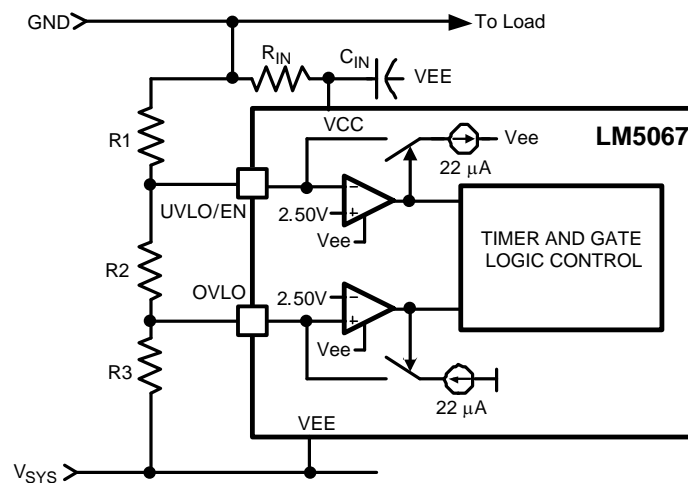

**Figure 14. UVLO and OVLO Thresholds Set By R1-R3**

The procedure to calculate the resistor values is as follows:

- Determine the upper UVLO threshold ( $V_{\text{UVH}}$ ) to enable Q1, and the lower UVLO threshold ( $V_{\text{UVL}}$ ) to disable Q1.
- Determine the upper OVLO threshold ( $V_{\text{OVH}}$ ) to disable Q1.
- The lower OVLO threshold ( $V_{\text{OVL}}$ ), to enable Q1, cannot be chosen in advance in this case, but is determined after the values for R1-R3 are determined. If  $V_{\text{OVL}}$  must be accurately defined in addition to the other three thresholds, see Option B below.

The resistors are calculated as follows:

$$R1 = \frac{V_{\text{UVH}} - V_{\text{UVL}}}{22 \mu\text{A}} = \frac{V_{\text{UV(HYS)}}}{22 \mu\text{A}}$$

$$R3 = \frac{2.5\text{V} \times R1 \times V_{\text{UVL}}}{V_{\text{OVH}} \times (V_{\text{UVL}} - 2.5\text{V})}$$

$$R2 = \frac{2.5\text{V} \times R1}{V_{\text{UVL}} - 2.5\text{V}} - R3 \quad (10)$$

The lower OVLO threshold is calculated from:

$$V_{\text{OVL}} = \frac{[(R1 + R2) \times ((2.5\text{V}) - 22 \mu\text{A})] + 2.5\text{V}}{R3} \quad (11)$$

As an example, assume the application requires the following thresholds:  $V_{UVH} = -36V$ ,  $V_{UVL} = -32V$ ,  $V_{OVH} = -60V$ .

$$R1 = \frac{36V - 32V}{22 \mu A} = \frac{4V}{22 \mu A} = 182 \text{ k}\Omega$$

$$R3 = \frac{2.5V \times 182 \text{ k}\Omega \times 32V}{60V \times (32V - 2.5V)} = 8.23 \text{ k}\Omega$$

$$R2 = \frac{2.5V \times 182 \text{ k}\Omega}{(32V - 2.5V)} - 8.23 \text{ k}\Omega = 7.19 \text{ k}\Omega \quad (12)$$

The lower OVLO threshold calculates to  $-55.8V$ , and the OVLO hysteresis is  $4.2V$ . Note that the OVLO hysteresis is always slightly greater than the UVLO hysteresis in this configuration.

When the R1-R3 resistor values are known, the threshold voltages and hysteresis are calculated from the following:

$$V_{UVH} = 2.5V + \left[ R1 \times (22 \mu A + \frac{2.5V}{(R2 + R3)}) \right]$$

$$V_{UVL} = \frac{2.5V \times (R1 + R2 + R3)}{R2 + R3}$$

$$V_{UV(HYS)} = R1 \times 22 \mu A$$

$$V_{OVH} = \frac{2.5V \times (R1 + R2 + R3)}{R3}$$

$$V_{OVL} = \left[ (R1 + R2) \times \frac{2.5V}{R3} - 22 \mu A \right] + 2.5V$$

$$V_{OV(HYS)} = (R1 + R2) \times 22 \mu A \quad (13)$$

---

**NOTE**

Ensure the voltages at the UVLO and OVLO pins do not exceed the Absolute Maximum ratings for those pins when the system voltage is at maximum.

---

**Option B:** If all four thresholds must be accurately defined, the configuration in [Figure 15](#) can be used.

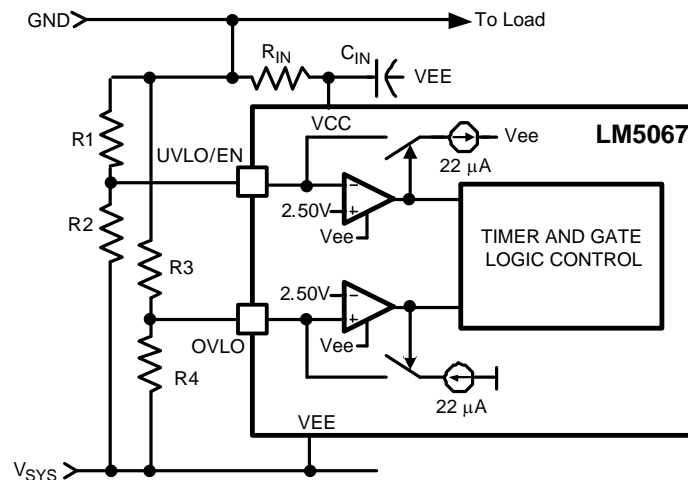

**Figure 15. Programming the Four Thresholds**

The four resistor values are calculated as follows:

- Determine the upper UVLO threshold ( $V_{UVH}$ ) to enable Q1, and the lower UVLO threshold ( $V_{UVL}$ ) to disable Q1.

$$R1 = \frac{V_{UVH} - V_{UVL}}{22 \mu A} = \frac{V_{UV(HYS)}}{22 \mu A}$$

$$R2 = \frac{2.5V \times R1}{(V_{UVL} - 2.5V)} \quad (14)$$

- Determine the upper OVLO threshold ( $V_{OVH}$ ) to disable Q1, and the lower OVLO threshold ( $V_{OVL}$ ) to enable Q1.

$$R3 = \frac{V_{OVH} - V_{OVL}}{22 \mu A} = \frac{V_{OV(HYS)}}{22 \mu A}$$

$$R4 = \frac{2.5V \times R3}{(V_{OVH} - 2.5V)} \quad (15)$$

As an example, assume the application requires the following thresholds:  $V_{UVH} = -22V$ ,  $V_{UVL} = -17V$ ,  $V_{OVH} = -60V$ , and  $V_{OVL} = -58V$ . Therefore  $V_{UV(HYS)} = 5V$ , and  $V_{OV(HYS)} = 2V$ . The resistor values are:

$$R1 = 227 \text{ k}\Omega, R2 = 39.1 \text{ k}\Omega$$

$$R3 = 90.9 \text{ k}\Omega, R4 = 3.95 \text{ k}\Omega$$

Where the R1-R4 resistor values are known, the threshold voltages and hysteresis are calculated from the following:

$$V_{UVH} = 2.5V + [R1 \times \frac{(2.5V + 22 \mu A)}{R2}]$$

$$V_{UVL} = \frac{2.5V \times (R1 + R2)}{R2}$$

$$V_{UV(HYS)} = R1 \times 22 \mu A$$

$$V_{OVH} = \frac{2.5V \times (R3 + R4)}{R4}$$

$$V_{OVL} = 2.5V + [R3 \times \frac{(2.5V - 22 \mu A)}{R4}]$$

$$V_{OV(HYS)} = R3 \times 22 \mu A$$

(16)

**NOTE**

Ensure the voltages at the UVLO and OVLO pins do not exceed the Absolute Maximum ratings for those pins when the system voltage is at maximum.

**Option C:** The minimum UVLO level is obtained by connecting the UVLO pin to VCC as shown in Figure 16. Q1 is switched on when the operating voltage reaches the POR<sub>EN</sub> threshold (≈8.4V). The OVLO thresholds are set by R3 and R4 using the procedure in Option B.

**NOTE**

Ensure the voltage at the OVLO pin does not exceed the Absolute Maximum ratings for that pin when the system voltage is at maximum.

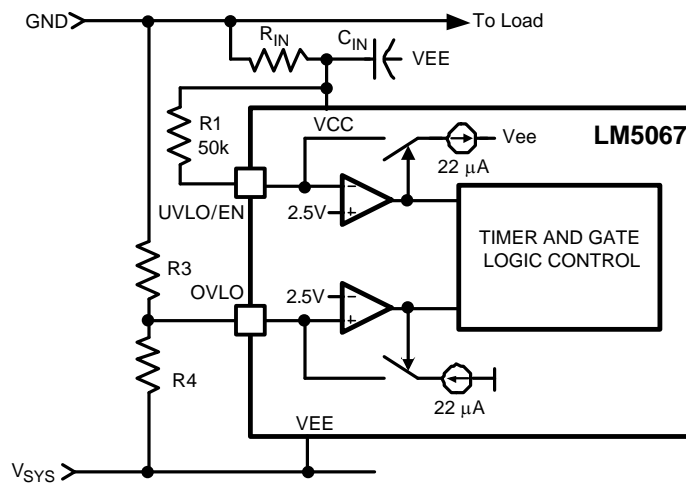

Figure 16. UVLO = POR<sub>EN</sub>

**Option D:** The OVLO function can be disabled by connecting the OVLO pin to VEE. The UVLO thresholds are set as described in Option B or Option C.

## SHUTDOWN / ENABLE CONTROL

Figure 17 shows how to use the UVLO/EN pin for remote shutdown and enable control. Taking the UVLO/EN pin below its 2.5V threshold (with respect to VEE) shuts off the load current. Upon releasing the UVLO/EN pin the LM5067 switches on the load current with in-rush current and power limiting. In Figure 18 the OVLO pin is used for remote shutdown and enable control. When the external transistor is off, the OVLO pin is above its 2.5V threshold (with respect to VEE) and the load current is shut off. Turning on the external transistor allows the LM5067 to switch on the load current with in-rush current and power limiting.

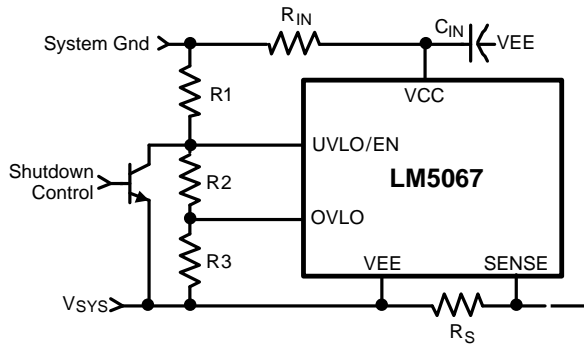

Figure 17. a) Shutdown/Enable Using the UVLO/EN Pin

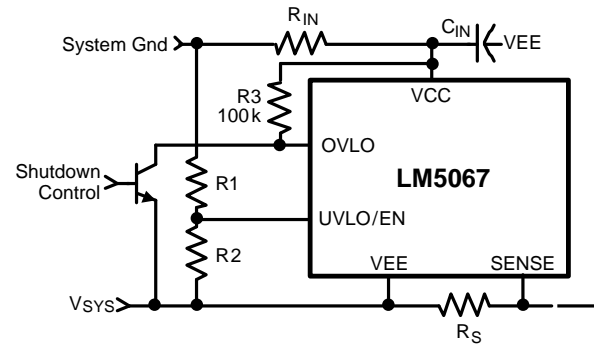

Figure 18. b) Shutdown/Enable Using the OVLO Pin

## POWER GOOD PIN

During initial power up, the Power Good pin (PGD) is high until the operating voltage ( $V_{CC} - V_{EE}$ ) increases above  $\approx 2V$ . PGD then switches low, remaining low as the system voltage and the operating voltage increase. After Q1 is switched on, when the voltage at the OUT pin is within 1.23V of the SENSE pin (Q1's  $V_{DS} < 1.23V$ ), PGD switches high indicating the output voltage is at, or nearly at, its final value. Any of the following situations will cause PGD to switch low within  $\approx 10 \mu s$ :

- The  $V_{DS}$  of Q1 increases above 2.5V.
- The system input voltage decreases below the UVLO level.
- The system input voltage increase above the OVLO level.
- The TIMER pin increases to 4V due to a fault condition.

A pull-up resistor is required at PGD as shown in Figure 19. The pull-up voltage ( $V_{PGD}$ ) can be as high as 80V above VEE, with transient capability to 100V, and can be higher or lower than the system ground.

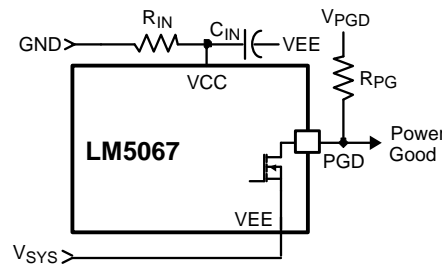

Figure 19. Power Good Output

If a delay is required at PGD, suggested circuits are shown in Figure 20. In Figure 20a, capacitor  $C_{PG}$  adds delay to the rising edge, but not to the falling edge. In Figure 20b, the rising edge is delayed by  $R_{PG1} + R_{PG2}$  and  $C_{PG}$ , while the falling edge is delayed a lesser amount by  $R_{PG2}$  and  $C_{PG}$ . Adding a diode across  $R_{PG2}$ , Figure 20c allows for equal delays at the two edges, or a short delay at the rising edge and a long delay at the falling edge.

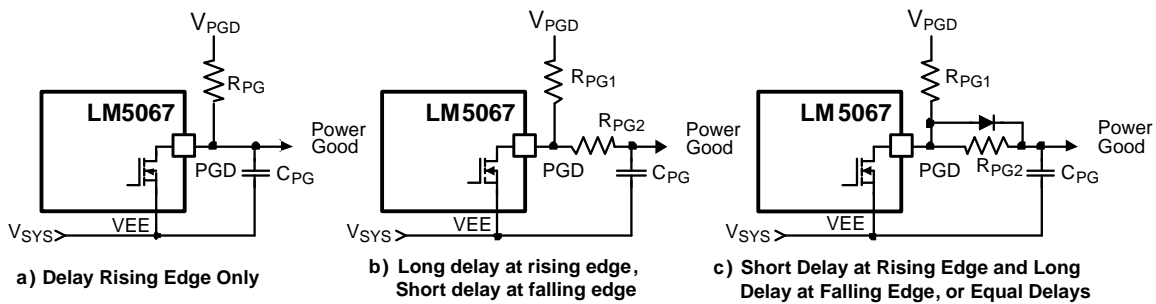

Figure 20. Adding Delay to the Power Good Output Pin

## Design-in Procedure

The recommended design-in procedure for the LM5067 is as follows:

- Determine the minimum and maximum system voltages ( $V_{EE}$ ). Select the input resistor ( $R_{IN}$ ) to provide at least 2 mA into the VCC pin at the minimum system voltage. The resistor's power rating must be suitable for its power dissipation at maximum system voltage ( $(V_{SYS} - 13V)^2/R_{IN}$ ).
- Determine the current limit threshold ( $I_{LIM}$ ). This threshold must be higher than the normal maximum load current, allowing for tolerances in the current sense resistor value and the LM5067 Current Limit threshold voltage. Use equation 1 to determine the value for  $R_S$ .
- Determine the maximum allowable power dissipation for the series pass FET (Q1), using the device's SOA information. Use equation 2 to determine the value for  $R_{PWR}$ .
- Determine the value for the timing capacitor at the TIMER pin ( $C_T$ ) using equation 3. **The fault timeout period ( $t_{FAULT}$ ) must be longer than the circuit's turn-on-time.** The turn-on time can be estimated using the equations in the Turn-on Time section of this data sheet, but should be verified experimentally. Allow for tolerances in the values of the external capacitors, sense resistor, and the LM5067 Electrical Characteristics for the TIMER pin, current limit and power limit. Review the resulting insertion time, and the restart timing if the LM5067-2 is used.
- Choose option A, B, C, or D from the UVLO, OVLO section of the Application Information for setting the UVLO and OVLO thresholds and hysteresis. Use the procedure in the appropriate option to determine the resistor values at the UVLO and OVLO pins.
- Choose the appropriate voltage, and pull-up resistor, for the Power Good output.

## PC Board Guidelines

The following guidelines should be followed when designing the PC board for the LM5067:

- Place the LM5067 close to the board's input connector to minimize trace inductance from the connector to the FET.
- Place  $R_{IN}$  and  $C_{IN}$  close to the VCC and VEE pins to keep transients below the Absolute Maximum rating of the LM5067. Transients of several volts can easily occur when the load current is shut off.
- The sense resistor ( $R_S$ ) should be close to the LM5067, and connected to it using the Kelvin techniques shown in Figure 10.
- The high current path from the board's input to the load, and the return path (via Q1), should be parallel and close to each other wherever possible to minimize loop inductance.
- The VEE connection for the various components around the LM5067 should be connected directly to each other, and to the LM5067's VEE pin, and then connected to the system VEE at one point. Do not connect the various components to each other through the high current VEE track.
- Provide adequate heat sinking for the series pass device (Q1) to help reduce thermal stresses during turn-on and turn-off.
- The board's edge connector can be designed to shut off the LM5067 as the board is removed, before the supply voltage is disconnected from the LM5067. In Figure 21 the voltage at the UVLO/EN pin goes to VEE before  $V_{SYS}$  is removed from the LM5067 due to the shorter edge connector pin. When the board is inserted into the edge connector, the system voltage is applied to the LM5067's VEE and VCC pins before voltage is applied to the UVLO/EN pin.

- If power dissipation within the LM5067 is high, an exposed copper pad should be provided beneath the package, and that pad should be connected to exposed copper on the board's other side with as many vias as possible. See [Thermal Considerations](#).

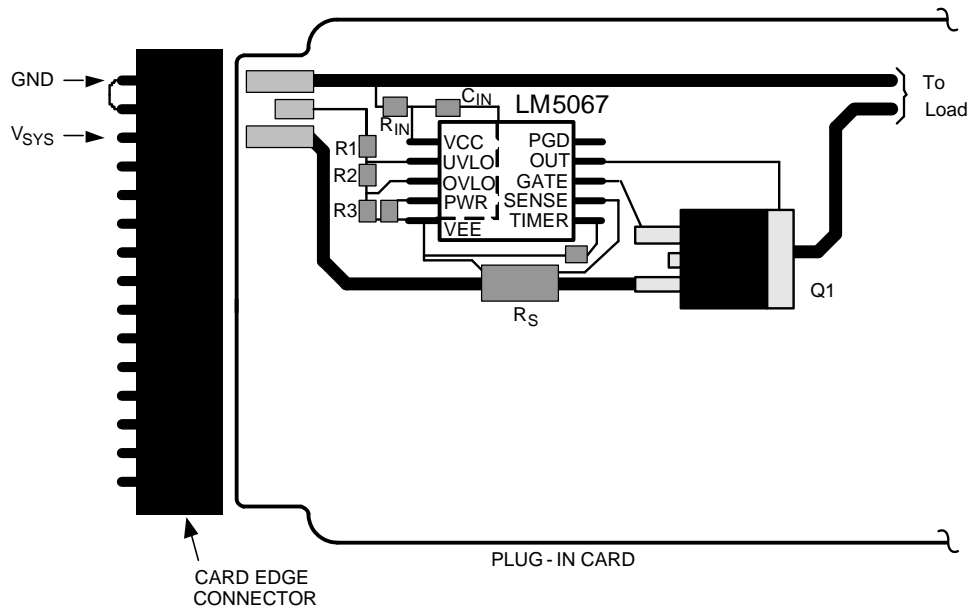

**Figure 21. Suggested Board Connector Design**

## Thermal Considerations

The LM5067 should be operated so that its junction temperature does not exceed 125°C. The junction temperature is equal to:

$$T_J = T_A + (R_{\theta JA} \times P_D)$$

where

- $T_A$  is the ambient temperature
  - $R_{\theta JA}$  is the thermal resistance of the LM5067
- (17)

$P_D$  is the power dissipated within the LM5067, calculated from:

$$P_D = 13V \times I_{CC}$$

where

- $I_{CC}$  is the current into the VCC pin (the current through the  $R_{IN}$  resistor).
- (18)

Values for  $R_{\theta JA}$  and  $R_{\theta JC}$  are in [Electrical Characteristics](#).

## System Considerations

1. Continued proper operation of the LM5067 hot swap circuit requires capacitance be present on the supply side of the connector into which the hot swap circuit is plugged in, as depicted in [Figure 5](#). The capacitor in the "Live Backplane" section is necessary to absorb the transient generated whenever the hot swap circuit shuts off the load current. If the capacitance is not present, inductance in the supply lines will generate a voltage transient at shut-off which can exceed the absolute maximum rating of the LM5067, resulting in its destruction.
2. If the load powered via the LM5067 hot swap circuit has inductive characteristics, a diode is required across the LM5067's output to provide a recirculating path for the load's current. Adding the diode prevents possible damage to the LM5067 as the OUT pin will be taken above ground by the inductive load at shutoff. See [Figure 22](#).

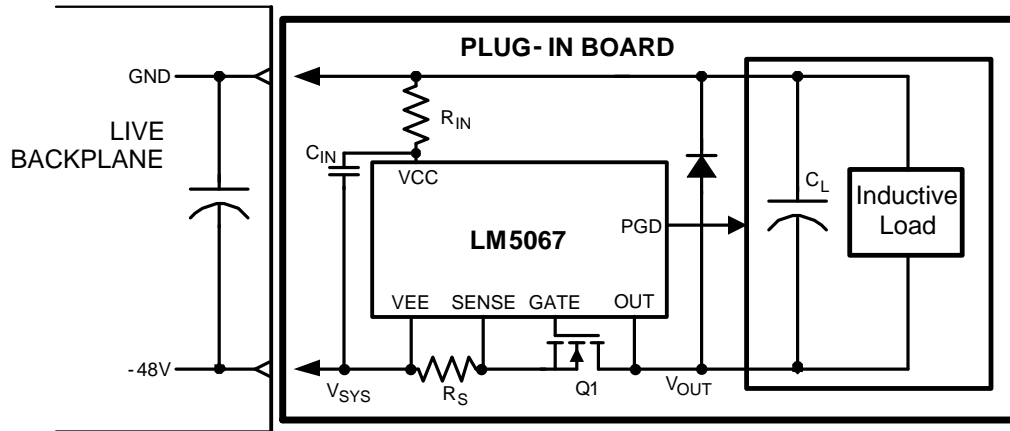

Figure 22. Output Diode Required for Inductive Loads

## REVISION HISTORY

Changes from Revision B (March 2013) to Revision C	Page
• Changed layout of National Data Sheet to TI format .....	<a href="#">27</a>

**PACKAGING INFORMATION**

Orderable Device	Status (1)	Package Type	Package Drawing	Pins	Package Qty	Eco Plan (2)	Lead/Ball Finish (6)	MSL Peak Temp (3)	Op Temp (°C)	Device Marking (4/5)	Samples
LM5067MM-1/NOPB	ACTIVE	VSSOP	DGS	10	1000	Green (RoHS & no Sb/Br)	CU SN	Level-1-260C-UNLIM	-40 to 125	SRUB	<a href="#">Samples</a>
LM5067MM-2/NOPB	ACTIVE	VSSOP	DGS	10	1000	Green (RoHS & no Sb/Br)	CU SN	Level-1-260C-UNLIM	-40 to 125	SRVB	<a href="#">Samples</a>
LM5067MMX-2/NOPB	ACTIVE	VSSOP	DGS	10	3500	Green (RoHS & no Sb/Br)	CU SN	Level-1-260C-UNLIM	-40 to 125	SRVB	<a href="#">Samples</a>
LM5067MW-1/NOPB	ACTIVE	SOIC	NPA	14	50	Green (RoHS & no Sb/Br)	CU SN	Level-3-260C-168 HR		LM5067 MW-1	<a href="#">Samples</a>
LM5067MWX-1/NOPB	ACTIVE	SOIC	NPA	14	1000	Green (RoHS & no Sb/Br)	CU SN	Level-3-260C-168 HR	-40 to 125	LM5067 MW-1	<a href="#">Samples</a>

(1) The marketing status values are defined as follows:

**ACTIVE:** Product device recommended for new designs.

**LIFEBUY:** TI has announced that the device will be discontinued, and a lifetime-buy period is in effect.

**NRND:** Not recommended for new designs. Device is in production to support existing customers, but TI does not recommend using this part in a new design.

**PREVIEW:** Device has been announced but is not in production. Samples may or may not be available.

**OBSELETE:** TI has discontinued the production of the device.

(2) **RoHS:** TI defines "RoHS" to mean semiconductor products that are compliant with the current EU RoHS requirements for all 10 RoHS substances, including the requirement that RoHS substance do not exceed 0.1% by weight in homogeneous materials. Where designed to be soldered at high temperatures, "RoHS" products are suitable for use in specified lead-free processes. TI may reference these types of products as "Pb-Free".

**RoHS Exempt:** TI defines "RoHS Exempt" to mean products that contain lead but are compliant with EU RoHS pursuant to a specific EU RoHS exemption.

**Green:** TI defines "Green" to mean the content of Chlorine (Cl) and Bromine (Br) based flame retardants meet JS709B low halogen requirements of <=1000ppm threshold. Antimony trioxide based flame retardants must also meet the <=1000ppm threshold requirement.

(3) MSL, Peak Temp. - The Moisture Sensitivity Level rating according to the JEDEC industry standard classifications, and peak solder temperature.

(4) There may be additional marking, which relates to the logo, the lot trace code information, or the environmental category on the device.

(5) Multiple Device Markings will be inside parentheses. Only one Device Marking contained in parentheses and separated by a "-" will appear on a device. If a line is indented then it is a continuation of the previous line and the two combined represent the entire Device Marking for that device.

(6) Lead/Ball Finish - Orderable Devices may have multiple material finish options. Finish options are separated by a vertical ruled line. Lead/Ball Finish values may wrap to two lines if the finish value exceeds the maximum column width.

**Important Information and Disclaimer:** The information provided on this page represents TI's knowledge and belief as of the date that it is provided. TI bases its knowledge and belief on information provided by third parties, and makes no representation or warranty as to the accuracy of such information. Efforts are underway to better integrate information from third parties. TI has taken and continues to take reasonable steps to provide representative and accurate information but may not have conducted destructive testing or chemical analysis on incoming materials and chemicals. TI and TI suppliers consider certain information to be proprietary, and thus CAS numbers and other limited information may not be available for release.

In no event shall TI's liability arising out of such information exceed the total purchase price of the TI part(s) at issue in this document sold by TI to Customer on an annual basis.

**TAPE AND REEL INFORMATION**

**QUADRANT ASSIGNMENTS FOR PIN 1 ORIENTATION IN TAPE**

\*All dimensions are nominal

Device	Package Type	Package Drawing	Pins	SPQ	Reel Diameter (mm)	Reel Width W1 (mm)	A0 (mm)	B0 (mm)	K0 (mm)	P1 (mm)	W (mm)	Pin1 Quadrant
LM5067MM-1/NOPB	VSSOP	DGS	10	1000	178.0	12.4	5.3	3.4	1.4	8.0	12.0	Q1
LM5067MM-2/NOPB	VSSOP	DGS	10	1000	178.0	12.4	5.3	3.4	1.4	8.0	12.0	Q1
LM5067MMX-2/NOPB	VSSOP	DGS	10	3500	330.0	12.4	5.3	3.4	1.4	8.0	12.0	Q1
LM5067MWX-1/NOPB	SOIC	NPA	14	1000	330.0	16.4	10.9	9.5	3.2	12.0	16.0	Q1

## TAPE AND REEL BOX DIMENSIONS



\*All dimensions are nominal

Device	Package Type	Package Drawing	Pins	SPQ	Length (mm)	Width (mm)	Height (mm)
LM5067MM-1/NOPB	VSSOP	DGS	10	1000	210.0	185.0	35.0
LM5067MM-2/NOPB	VSSOP	DGS	10	1000	210.0	185.0	35.0
LM5067MMX-2/NOPB	VSSOP	DGS	10	3500	367.0	367.0	35.0
LM5067MWX-1/NOPB	SOIC	NPA	14	1000	367.0	367.0	38.0

MECHANICAL DATA

NPA0014B

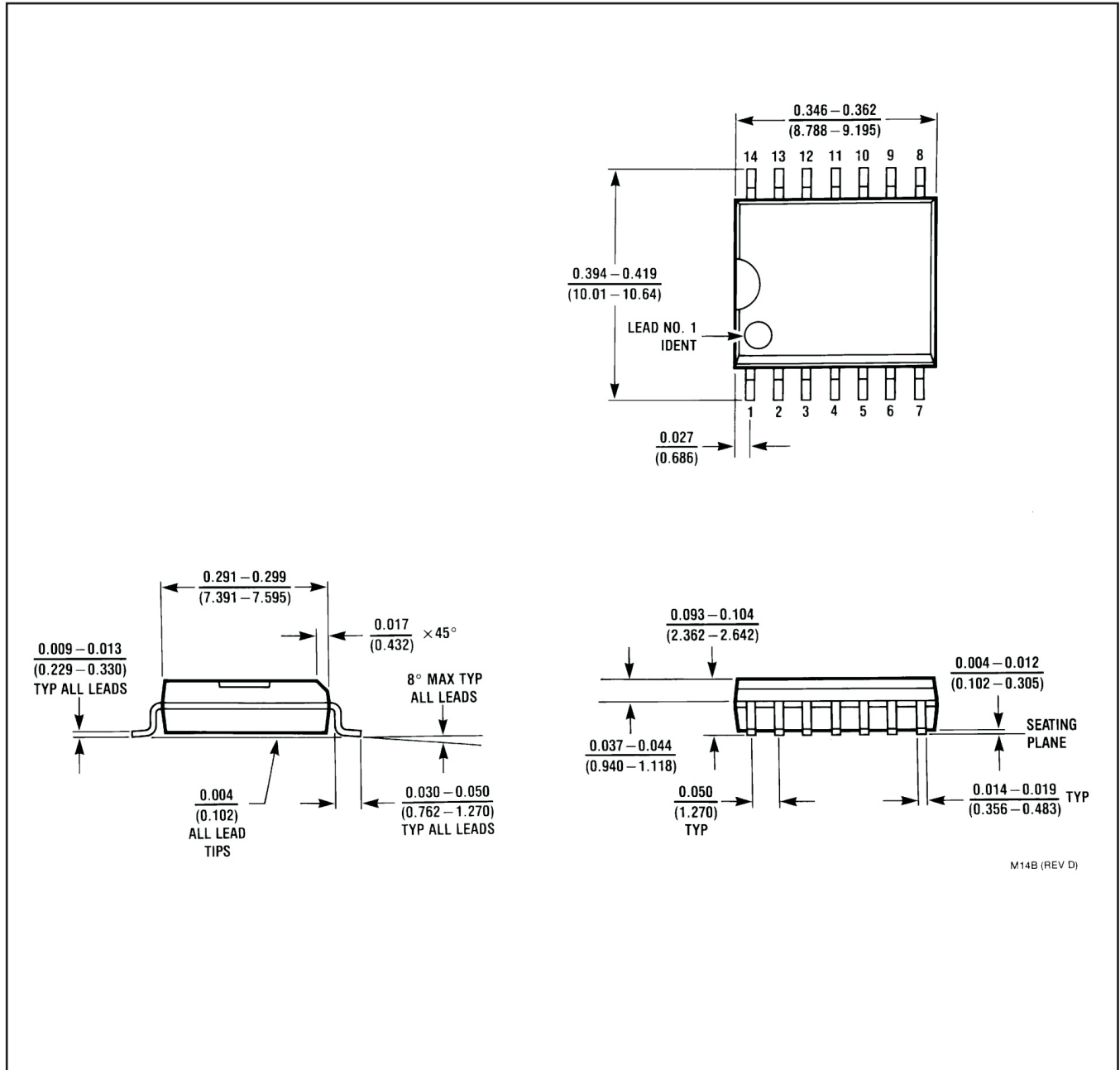

# DGS0010A



# PACKAGE OUTLINE

## VSSOP - 1.1 mm max height

SMALL OUTLINE PACKAGE

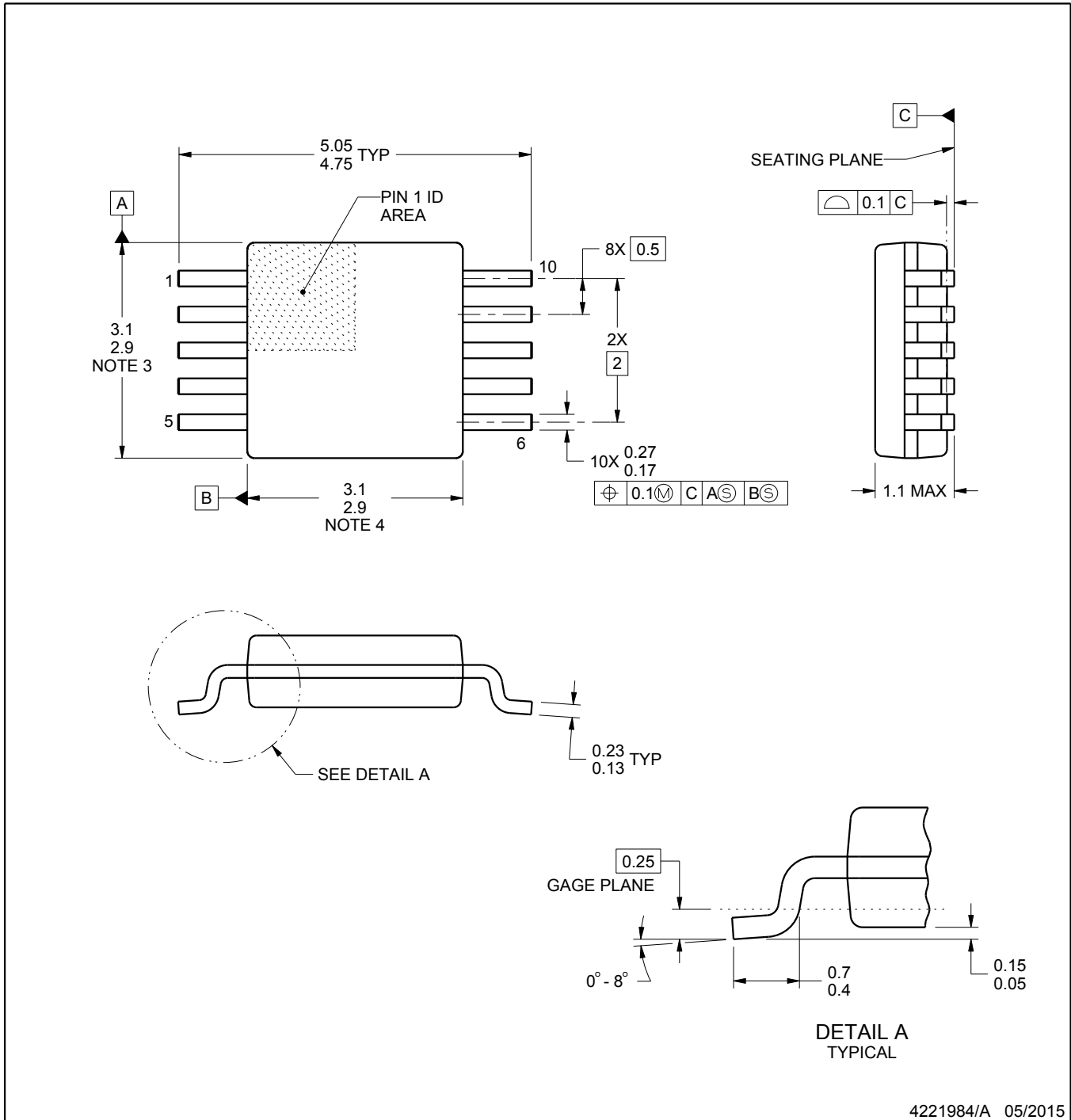

4221984/A 05/2015

### NOTES:

1. All linear dimensions are in millimeters. Any dimensions in parenthesis are for reference only. Dimensioning and tolerancing per ASME Y14.5M.
2. This drawing is subject to change without notice.
3. This dimension does not include mold flash, protrusions, or gate burrs. Mold flash, protrusions, or gate burrs shall not exceed 0.15 mm per side.
4. This dimension does not include interlead flash. Interlead flash shall not exceed 0.25 mm per side.
5. Reference JEDEC registration MO-187, variation BA.

# EXAMPLE BOARD LAYOUT

DGS0010A

VSSOP - 1.1 mm max height

SMALL OUTLINE PACKAGE



LAND PATTERN EXAMPLE  
SCALE:10X

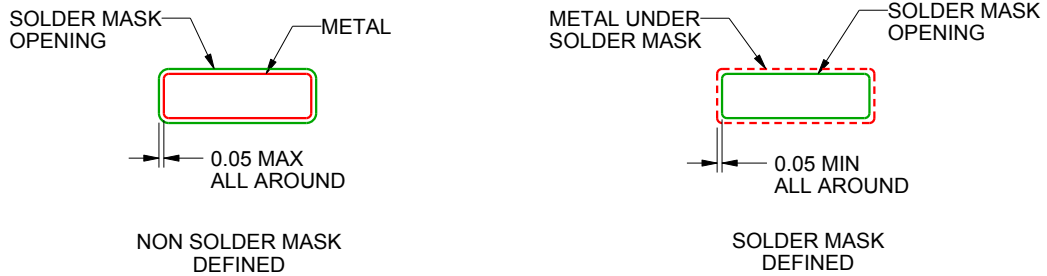

SOLDER MASK DETAILS  
NOT TO SCALE

4221984/A 05/2015

NOTES: (continued)

- 6. Publication IPC-7351 may have alternate designs.
- 7. Solder mask tolerances between and around signal pads can vary based on board fabrication site.

# EXAMPLE STENCIL DESIGN

DGS0010A

VSSOP - 1.1 mm max height

SMALL OUTLINE PACKAGE



SOLDER PASTE EXAMPLE  
BASED ON 0.125 mm THICK STENCIL  
SCALE:10X

4221984/A 05/2015

NOTES: (continued)

8. Laser cutting apertures with trapezoidal walls and rounded corners may offer better paste release. IPC-7525 may have alternate design recommendations.
9. Board assembly site may have different recommendations for stencil design.

## IMPORTANT NOTICE AND DISCLAIMER

TI PROVIDES TECHNICAL AND RELIABILITY DATA (INCLUDING DATASHEETS), DESIGN RESOURCES (INCLUDING REFERENCE DESIGNS), APPLICATION OR OTHER DESIGN ADVICE, WEB TOOLS, SAFETY INFORMATION, AND OTHER RESOURCES "AS IS" AND WITH ALL FAULTS, AND DISCLAIMS ALL WARRANTIES, EXPRESS AND IMPLIED, INCLUDING WITHOUT LIMITATION ANY IMPLIED WARRANTIES OF MERCHANTABILITY, FITNESS FOR A PARTICULAR PURPOSE OR NON-INFRINGEMENT OF THIRD PARTY INTELLECTUAL PROPERTY RIGHTS.



These resources are intended for skilled developers designing with TI products. You are solely responsible for (1) selecting the appropriate TI products for your application, (2) designing, validating and testing your application, and (3) ensuring your application meets applicable standards, and any other safety, security, or other requirements. These resources are subject to change without notice. TI grants you permission to use these resources only for development of an application that uses the TI products described in the resource. Other reproduction and display of these resources is prohibited. No license is granted to any other TI intellectual property right or to any third party intellectual property right. TI disclaims responsibility for, and you will fully indemnify TI and its representatives against, any claims, damages, costs, losses, and liabilities arising out of your use of these resources.

TI's products are provided subject to TI's Terms of Sale ([www.ti.com/legal/termsofsale.html](http://www.ti.com/legal/termsofsale.html)) or other applicable terms available either on [ti.com](http://ti.com) or provided in conjunction with such TI products. TI's provision of these resources does not expand or otherwise alter TI's applicable warranties or warranty disclaimers for TI products.

Mailing Address: Texas Instruments, Post Office Box 655303, Dallas, Texas 75265  
Copyright © 2019, Texas Instruments Incorporated

## Looking for pricing, stock, or lifecycle information?

Click below to explore more details on WIN SOURCE:

-  [View LM5067MW-1/NOPB on WIN SOURCE](#)
-  [Texas Instruments](#) Information

## Optimize Your Supply Chain with WIN SOURCE Solutions

-  Global Sourcing Solution
-  Obsolete Management
-  Cost Control Management
-  Shortage Management
-  Alternative Solution
-  Excess Inventory Management